



# Parker Fluid Control Angle Body Valves

aerospace  
climate control  
electromechanical  
filtration  
fluid & gas handling  
hydraulics  
pneumatics  
process control  
sealing & shielding



ENGINEERING YOUR SUCCESS.

# Angle Body Valve Key Features

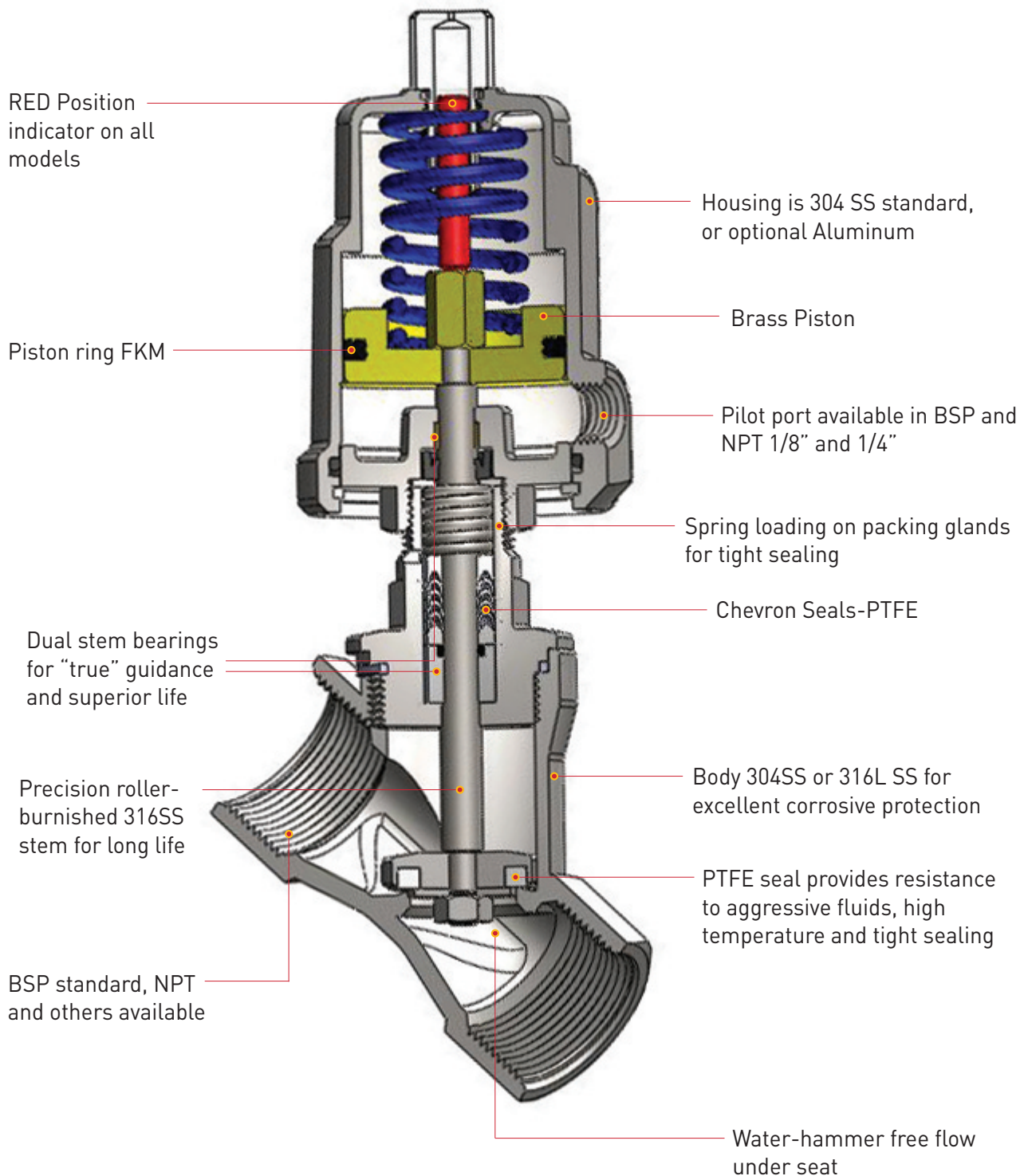

# Angle Body Valves

## TABLE OF CONTENTS

INDEX .....	1
GENERAL SPECIFICATIONS .....	2
NORMALLY CLOSED, FLOW OVER THE SEAT .....	3-6
NORMALLY OPEN, FLOW OVER THE SEAT .....	7-8
NORMALLY CLOSED, FLOW UNDER THE SEAT, ANTI WATER HAMMER CONSTRUCTION .....	9-10
NORMALLY OPEN, FLOW UNDER THE SEAT .....	11-12
NORMALLY CLOSED, COMPACT DESIGN .....	13-14
NORMALLY OPEN, COMPACT DESIGN .....	15-16
SERIES PA DRAWINGS AND DIMENSIONS .....	17-22
NUMBERING SYSTEM .....	23
SOLENOID VALVES FOR CONTROLLING THE PA ANGLE BODY VALVES .....	24
3 Way Direct Acting Pilot Control Valves, Banjo Valve .....	25

### WARNING!

**FAILURE OR IMPROPER SELECTION OR IMPROPER USE OF THE PRODUCTS AND/OR SYSTEMS DESCRIBED HEREIN OR RELATED ITEMS CAN CAUSE DEATH, PERSONAL INJURY AND PROPERTY DAMAGE.**

This document and other information from Parker Hannifin Corporation, its subsidiaries and authorized distributors provide product and/or systems options for further investigation by users having technical expertise. It is important that you analyze all aspects of your application and review the information concerning the product or system in the current product catalog. Due to the variety of operating conditions and applications for these products or systems, the user, through its own analysis and testing, is solely responsible for making the final selection of the products and systems and assuring that all performance, safety and warning requirements of the application are met.

The products described herein, including without limitation, product features, specifications, designs, availability and pricing, are subject to change by Parker Hannifin Corporation and its subsidiaries at anytime without notice.

## Introduction

The portfolio is endowed with numerous benefits including:

- A full-line of normally closed and normally open valves ranging in size from 3/8 inch to 2 1/2 inches.
- State of the art performance for long life, ease of service and tighter system integrity.
- Operating pressures up to 16 Bar (232 psi).
- Suitable for temperatures ranging from -10°C to 180°C /14°F to 356°F.
- Handles millions of cycles for high temperature and aggressive media.
- Separate Pilot Valves for both AC & DC requirements.
- Complete line of high temperature watertight coil designs suitable for all pilot control valves.
- Spare Parts Kits are available for main seat replacement.

Angle body valves are suitable for many process & industrial application requirements. Valve applications include but are not limited to the following areas:

- Food and Beverage Processing:
  - Brewery
  - water, steam, pasteurization, glycol solutions for cooling, de-aeration processes, blending, carbonation, thermal processes
  - Bottling & bottle washing equipment
  - "Clean-in-Place" systems
  - Dairy product processing
- Water Technology & Treatment:
  - Filtration technology
  - Pollution control equipment
- Textile Industry:
  - Bleaching, dyeing & drying equipment
  - Steam, water & additives requirements
- Cooling systems on injection molding machines
- Pharmaceutical & cosmetic industry
- Chemical Process technology
- Refrigeration & Cooling heat exchangers
- Sterilizers - steam supply up to 180°C ( 356°F )
- Water applications: Mining, Cement / Concrete Systems, Pulp & Paper
- General industrial applications of aggressive fluids with stainless materials
- Industrial Laundry Equipment
- Industrial Air Dryers

# Series PA - 2/2 - Way Angle Body Valves

## 3/8" to 2 1/2" BSP 16 Bar, 232 psi



### VALVE FEATURES

- Compact design, high flow rates
- Visual position indicator standard
- For temperatures from 14°F to 356°F / -10°C to 180°C
- Working pressures up to 16 Bar, 232 psi
- Dampened closing anti-water hammer design (fluid under seat)
- Metal actuator housing for exceptional durability in steam & mildly aggressive applications
- Valves satisfy the Pressure Equipment Directive 97/23/EC
- Mountable in any position
- Tight shut-off and Long Service Life
- Valve seats and seal components fully repairable

### Technical Specifications:

Body Material	304 SS or 316 SS
Function	2/2 NC, NO, NC(antiwater hammer), double acting (with spring)
Nominal sizes	DN10-DN65, 3/8" to 2 1/2"
Connections	Threads- BSP, BSPT, NPT, NPTF Welded- ISO1127/4200, DIN 11850.1, DIN 11850.2, DIN 11850.3, SMS3008, ASME BPE
	Flanges
Max Working Pressure	16 BAR, 232 PSI
Differential Pressure	See Specification Charts
Pilot Pressure	3 Bar to 10 Bar. 43.5 PSI to 145 PSI
Actuator Material	304 SS, or Aluminum
Maximum Fluid Temp	-10°C to 180°C, 14°F to 356°F
<b>Optional</b>	
Ambient Temperature	-10°C to 60°C, 14°F to 140°F
Seat Seal material	PTFE/RTFE
Packing Gland	PTFE, PTFE and Carbon
Viscosity	Maximum 600mm <sup>2</sup> /s(600cSt, 80° E, 2700 SSU
Vacuum	maximum 0.0295 mercury (Hg)
Leakage	ANSI Class VI shutoff
Installation	Any Position
Optical Position Indicator	Standard on all sizes
Pilot Control Media	Air, Neutral Gas, Water
Fluids handled	Inert gases, hot water, oils, steam, aggressive and corrosive fluids
Pilot Port Size	1/8" for 32,40,50, & 63 mm actuators, 1/4" for 80, 100 mm actuators

Normally Closed Valve

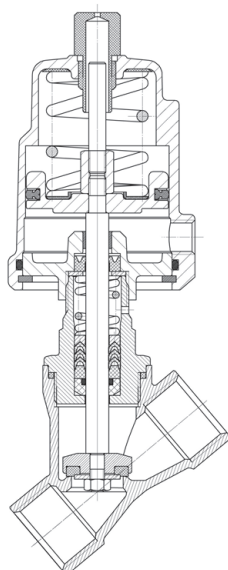

Normally Open Valve

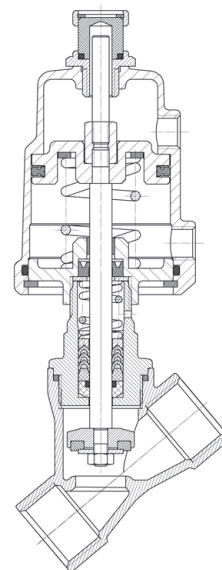



# SERIES PA - NORMALLY CLOSED VALVES - FLOW DIRECTION OVER SEAT

Model Numbers Shown are BSP threads



## 304 Stainless Steel Actuators with 304 Stainless Steel Bodies

Size	Port size	Orifice (mm)	Actuator (mm)	Kv (m³/h)	Operating Pressure Differential		Pilot Control Pressure Range		Model Number	Net Weight kgs
					Bar	PSI	Bar	PSI		
DN10	3/8"	13	40	4.7	0-16	0-232	4-10	58-145	PA10S1G3S040S	0.78
			50	4.7	0-16	0-232	3-10	44-145	PA10S1G3S050S	1.01
DN15	1/2"	13	40	4.7	0-16	0-232	4-10	58-145	PA15S1G4S040S	0.80
			50	4.7	0-16	0-232	3-10	44-145	PA15S1G4S050S	1.03
DN20	3/4"	18	50	9.5	0-16	0-232	3-4	44-58	PA20S1G5S050S	1.06
DN25	1"	24	50	18.1	0-16	0-232	3-5.5	44-80	PA25S1G6S050S	1.38
			63	18.1	0-16	0-232	3-3.5	44-51	PA25S1G6S063S	2.05
DN32	1-1/4"	31	63	23.1	0-16	0-232	3-5	44-73	PA32S1G7S063S	2.40
DN40	1-1/2"	35	63	32.9	0-16	0-232	3-6	44-87	PA40S1G8S063S	2.75
DN50	2"	45	63	52.8	0-10	0-145	3-6.5	44-95	PA50S1G9S063S	3.50
			80	52.8	0-16	0-232	3-6.6	44-96	PA50S1G9S080S	4.62
			100	52.8	0-16	0-232	3-5	44-73	PA50S1G9S100S	5.16
DN65	2-1/2"	65	100	82	0-10	0-145	3-6	44-87	PA65S1GTS100S	8.65

For NPT porting, change "G" to "N" in 7<sup>th</sup> position

To obtain Cv multiply Kv by 1.16

To obtain lbs., multiply kgs by 2.2

## 304 Stainless Steel Actuators with 316L Stainless Steel Bodies

Size	Port size	Orifice (mm)	Actuator (mm)	Kv (m³/h)	Operating Pressure Differential		Pilot Control Pressure Range		Model Number	Net Weight kgs
					Bar	PSI	Bar	PSI		
DN10	3/8"	13	40	4.7	0-16	0-232	4-10	58-145	PA10S1G3R040S	0.78
			50	4.7	0-16	0-232	3-10	44-145	PA10S1G3R050S	1.01
DN15	1/2"	13	40	4.7	0-16	0-232	4-10	58-145	PA15S1G4R040S	0.80
			50	4.7	0-16	0-232	3-10	44-145	PA15S1G4R050S	1.03
DN20	3/4"	18	50	9.5	0-16	0-232	3-4	44-58	PA20S1G5R050S	1.06
DN25	1"	24	50	18.1	0-16	0-232	3-5.5	44-80	PA25S1G6R050S	1.38
			63	18.1	0-16	0-232	3-3.5	44-51	PA25S1G6R063S	2.05
DN32	1-1/4"	31	63	23.1	0-16	0-232	3-5	44-73	PA32S1G7R063S	2.40
DN40	1-1/2"	35	63	32.9	0-16	0-232	3-6	44-87	PA40S1G8R063S	2.75
DN50	2"	45	63	52.8	0-10	0-145	3-6.5	44-95	PA50S1G9R063S	3.50
			80	52.8	0-16	0-232	3-6.6	44-96	PA50S1G9R080S	4.62
			100	52.8	0-16	0-232	3-5	44-73	PA50S1G9R100S	5.16
DN65	2-1/2"	65	100	82	0-10	0-145	3-6	44-87	PA65S1GTR100S	8.65

For NPT porting, change "G" to "N" in 7<sup>th</sup> position

To obtain Cv multiply Kv by 1.16

To obtain lbs., multiply kgs by 2.2

## Control Pressure & Operating Pressure Charts for the Normally Closed valves with 304 SS actuators

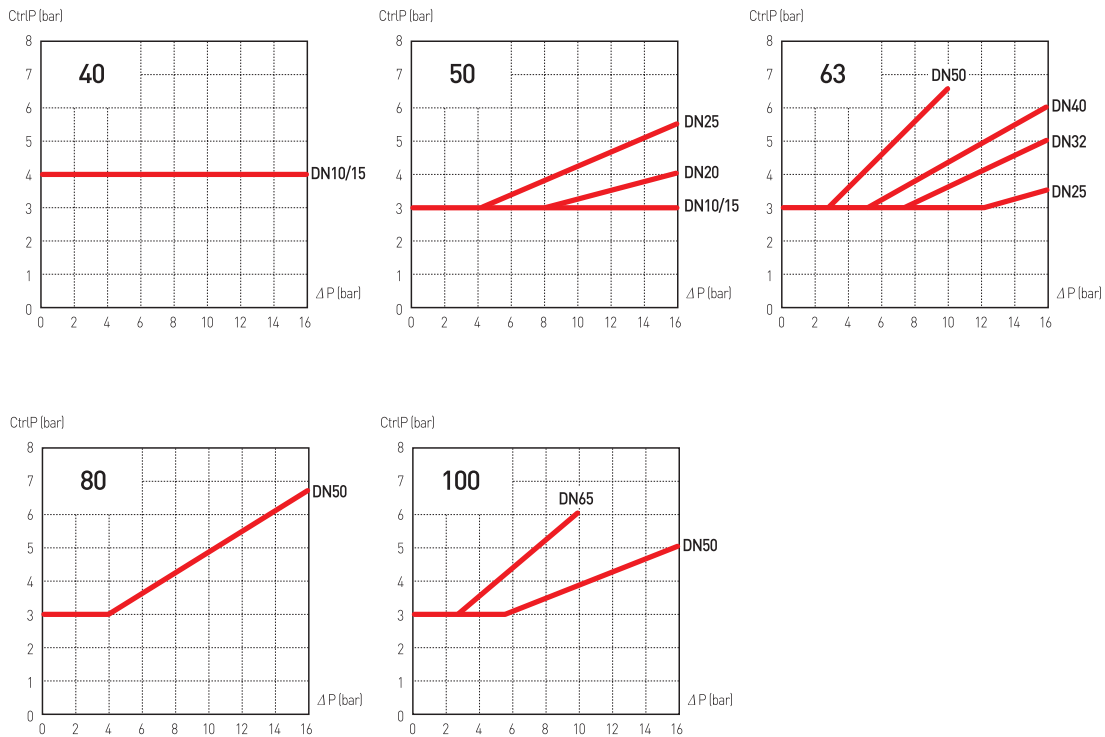

## Flow Charts

Normally Closed Valve

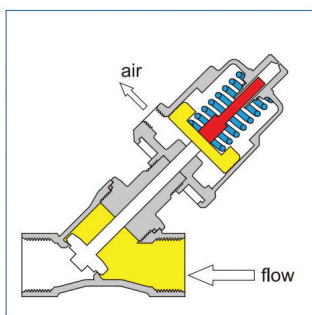

Normally Open Valve

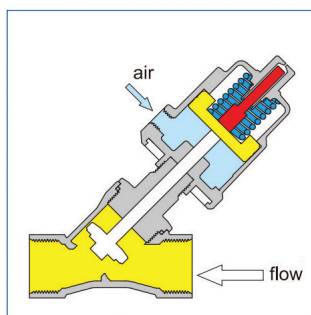

# SERIES PA - NORMALLY CLOSED VALVES - FLOW DIRECTION OVER SEAT

Model Numbers Shown are BSP threads



## Aluminum Actuator with 304 Stainless Steel Bodies

Size	Port size	Orifice (mm)	Actuator (mm)	Kv (m <sup>3</sup> /h)	Operating Pressure Differential		Pilot Control Pressure Range		Model Number	Net Weight kgs
					Bar	PSI	Bar	PSI		
DN10	3/8"	13	50	4.7	0-16	0-232	3-10	44-145	PA10S1G3S050A	0.75
DN15	1/2"	13	50	4.7	0-16	0-232	3-10	44-145	PA15S1G4S050A	0.80
DN20	3/4"	18	50	9.5	0-16	0-232	3-4	44-58	PA20S1G5S050A	0.90
DN25	1"	24	50	18.1	0-16	0-232	3-5.5	44-80	PA25S1G6S050A	1.27
			63	18.1	0-16	0-232	3-4	44-58	PA25S1G6S063A	1.65
DN32	1-1/4"	31	63	23.1	0-16	0-232	3-5.5	44-80	PA32S1G7S063A	1.89
DN40	1-1/2"	35	63	32.9	0-16	0-232	3-6.5	44-95	PA40S1G8S063A	2.15
DN50	2"	45	63	52.8	0-10	0-145	3-6.5	44-95	PA50S1G9S063A	2.98
			80	52.8	0-16	0-232	3-6.6	44-96	PA50S1G9S080A	3.56
			100	52.8	0-16	0-232	3-5	44-73	PA50S1G9S100A	4.75
DN65	2-1/2"	65	100	82	0-10	0-145	3-6	44-87	PA65S1GTS100A	5.50

For NPT porting, change "G" to "N" in 7<sup>th</sup> position

To obtain Cv multiply Kv by 1.16

To obtain lbs., multiply kgs by 2.2

## Aluminum Actuator with 316L Stainless Steel Bodies

Size	Port size	Orifice (mm)	Actuator (mm)	Kv (m <sup>3</sup> /h)	Operating Pressure Differential		Pilot Control Pressure Range		Model Number	Net Weight kgs
					Bar	PSI	Bar	PSI		
DN10	3/8"	13	50	4.7	0-16	0-232	3-10	44-145	PA10S1G3R050A	0.75
DN15	1/2"	13	50	4.7	0-16	0-232	3-10	44-145	PA15S1G4R050A	0.80
DN20	3/4"	18	50	9.5	0-16	0-232	3-4	44-58	PA20S1G5R050A	0.90
DN25	1"	24	50	18.1	0-16	0-232	3-5.5	44-80	PA25S1G6R050A	1.27
			63	18.1	0-16	0-232	3-4	44-58	PA25S1G6R063A	1.65
DN32	1-1/4"	31	63	23.1	0-16	0-232	3-5.5	44-80	PA32S1G7R063A	1.89
DN40	1-1/2"	35	63	32.9	0-16	0-232	3-6.5	44-95	PA40S1G8R063A	2.15
DN50	2"	45	63	52.8	0-10	0-145	3-6.5	44-95	PA50S1G9R063A	2.98
			80	52.8	0-16	0-232	3-6.6	44-96	PA50S1G9R080A	3.56
			100	52.8	0-16	0-232	3-5	44-73	PA50S1G9R100A	4.75
DN65	2-1/2"	65	100	82	0-10	0-145	3-6	44-87	PA65S1GTR100A	5.50

For NPT porting, change "G" to "N" in 7<sup>th</sup> position

To obtain Cv multiply Kv by 1.16

To obtain lbs., multiply kgs by 2.2

## Control Pressure & Operating Pressure Charts for the Normally Closed valves with aluminum actuators

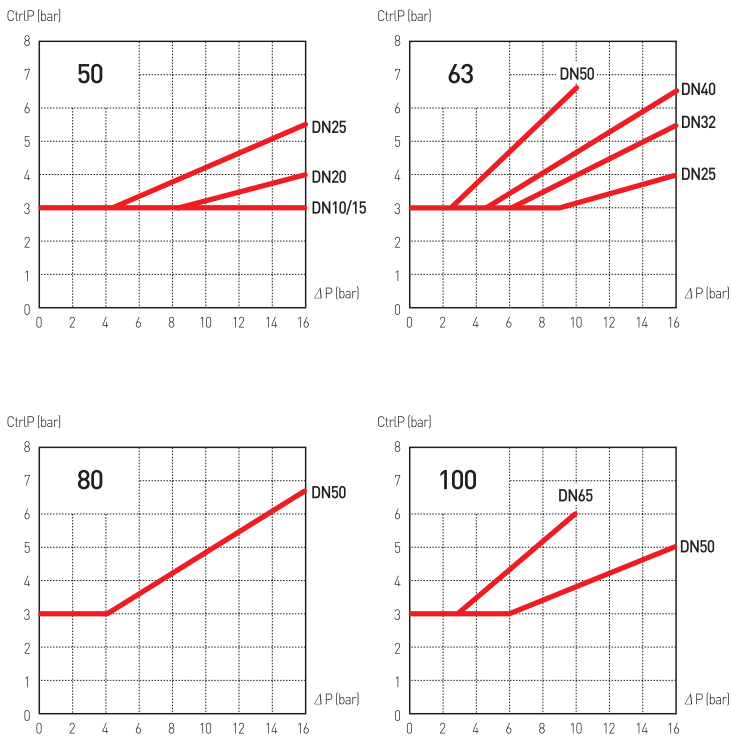

## Flow Charts

Normally Closed Valve

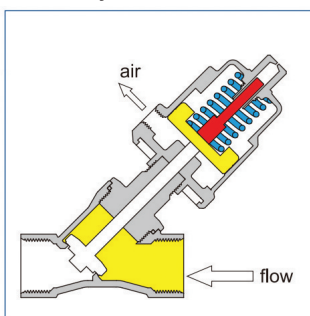

Normally Open Valve

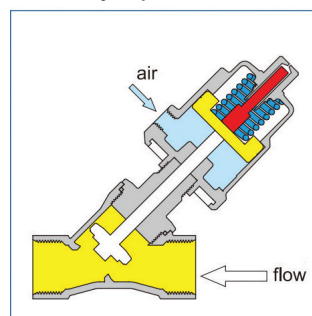

# SERIES PA - NORMALLY OPEN VALVES - FLOW DIRECTION OVER SEAT

Model Numbers Shown are BSP threads



## 304 Stainless Steel Actuators with 304 Stainless Steel Bodies

Size	Port size	Orifice (mm)	Actuator (mm)	Kv (m³/h)	Operating Pressure Differential		Pilot Control Pressure Range		Model Number	Net Weight kgs
					Bar	PSI	Bar	PSI		
DN10	3/8"	13	50	4.7	0-16	0-232	3.5-10	51-145	PA10S2G3S050S	1.0
DN15	1/2"	13	50	4.7	0-16	0-232	3.5-10	51-145	PA15S2G4S050S	1.03
DN20	3/4"	18	50	9.5	0-16	0-232	3.5-10	51-145	PA20S2G5S050S	1.06
DN25	1"	24	63	18.1	0-16	0-232	4.5-10	66-145	PA25S2G6S063S	2.05
DN32	1-1/4"	31	63	23.1	0-14	0-203	4.5-10	66-145	PA32S2G7S063S	2.40
DN40	1-1/2"	35	63	32.9	0-11	0-160	4.5-10	66-145	PA40S2G8S063S	2.75
DN50	2"	45	63	52.8	0-6	0-87	5-10	73-145	PA50S2G9S063S	3.50
			80	52.8	0-12	0-174	5-10	73-145	PA50S2G9S080S	4.62

For NPT porting, change "G" to "N" in 7<sup>th</sup> position  
 To obtain Cv multiply Kv by 1.16  
 To obtain lbs., multiply kgs by 2.2

## 304 Stainless Steel Actuators with 316L Stainless Steel Bodies

Size	Port size	Orifice (mm)	Actuator (mm)	Kv (m³/h)	Operating Pressure Differential		Pilot Control Pressure Range		Model Number	Net Weight kgs
					Bar	PSI	Bar	PSI		
DN10	3/8"	13	50	4.7	0-16	0-232	3.5-10	51-145	PA10S2G3R050S	1.0
DN15	1/2"	13	50	4.7	0-16	0-232	3.5-10	51-145	PA15S2G4R050S	1.03
DN20	3/4"	18	50	9.5	0-16	0-232	3.5-10	51-145	PA20S2G5R050S	1.06
DN25	1"	24	63	18.1	0-16	0-232	4.5-10	66-145	PA25S2G6R063S	2.05
DN32	1-1/4"	31	63	23.1	0-14	0-203	4.5-10	66-145	PA32S2G7R063S	2.40
DN40	1-1/2"	35	63	32.9	0-11	0-160	4.5-10	66-145	PA40S2G8R063S	2.75
DN50	2"	45	63	52.8	0-6	0-87	5-10	73-145	PA50S2G9R063S	3.50
			80	52.8	0-12	0-174	5-10	73-145	PA50S2G9R080S	4.62

For NPT porting, change "G" to "N" in 7<sup>th</sup> position  
 To obtain Cv multiply Kv by 1.16  
 To obtain lbs., multiply kgs by 2.2

## Control Pressure & Operating Pressure

Charts do not apply for Normally Open valves. A minimum pressure as noted above is all that is required, up to the maximum listed.

## Flow Charts

Normally Closed Valve

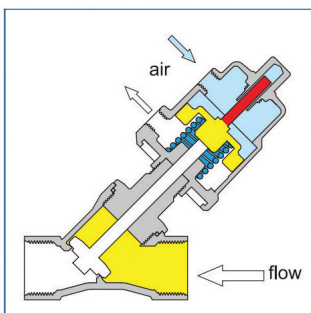

Normally Open Valve

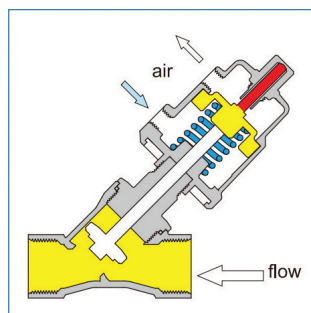



# SERIES PA - NORMALLY OPEN VALVES - FLOW DIRECTION OVER SEAT

Model Numbers Shown are BSP threads



## Aluminum Actuators with 304 Stainless Steel Bodies

Size	Port size	Orifice (mm)	Actuator (mm)	Kv (m³/h)	Operating Pressure Differential		Pilot Control Pressure Range		Model Number	Net Weight kgs
					Bar	PSI	Bar	PSI		
DN10	3/8"	13	50	4.7	0-16	0-232	3.5 -10	51-145	PA10S2G3S050A	
DN15	1/2"	13	50	4.7	0-16	0-232	3.5 -10	51-145	PA15S2G4S050A	
DN20	3/4"	18	50	9.5	0-16	0-232	3.5 -10	51-145	PA20S2G5S050A	
DN25	1"	24	63	18.1	0-16	0-232	4.5 -10	66-145	PA25S2G6S063A	
DN32	1-1/4"	31	63	23.1	0-14	0-232	4.5 -10	44-145	PA32S2G7S063A	
DN40	1-1/2"	35	63	32.9	0-11	0-232	4.5 -10	44-145	PA40S2G8S063A	
DN50	2"	45	63	52.8	0-6	0-87	5.0 -10	44-145	PA50S2G9S063A	
			80	52.8	0-12	0-174	5.0 -10	44-145	PA50S2G9S080A	

For NPT porting, change "G" to "N" in 7<sup>th</sup> position

To obtain Cv multiply Kv by 1.16

To obtain lbs., multiply Kgs by 2.2

## Aluminum Actuators with 316L Stainless Steel Bodies

Size	Port size	Orifice (mm)	Actuator (mm)	Kv (m³/h)	Operating Pressure Differential		Pilot Control Pressure Range		Model Number	Net Weight kgs
					Bar	PSI	Bar	PSI		
DN10	3/8"	13	50	4.7	0-16	0-232	3.5 -10	51-145	PA10S2G3R050A	
DN15	1/2"	13	50	4.7	0-16	0-232	3.5 -10	51-145	PA15S2G4R050A	
DN20	3/4"	18	50	9.5	0-16	0-232	3.5 -10	51-145	PA20S2G5R050A	
DN25	1"	24	63	18.1	0-16	0-232	4.5 -10	66-145	PA25S2G6R063A	
DN32	1-1/4"	31	63	23.1	0-14	0-232	4.5 -10	44-145	PA32S2G7R063A	
DN40	1-1/2"	35	63	32.9	0-11	0-232	4.5 -10	44-145	PA40S2G8R063A	
DN50	2"	45	63	52.8	0-6	0-87	5.0 -10	44-145	PA50S2G9R063A	
			80	52.8	0-12	0-174	5.0 -10	44-145	PA50S2G9R080A	

For NPT porting, change "G" to "N" in 7<sup>th</sup> position

To obtain Cv multiply Kv by 1.16

To obtain lbs., multiply Kgs by 2.2

## Control Pressure & Operating Pressure

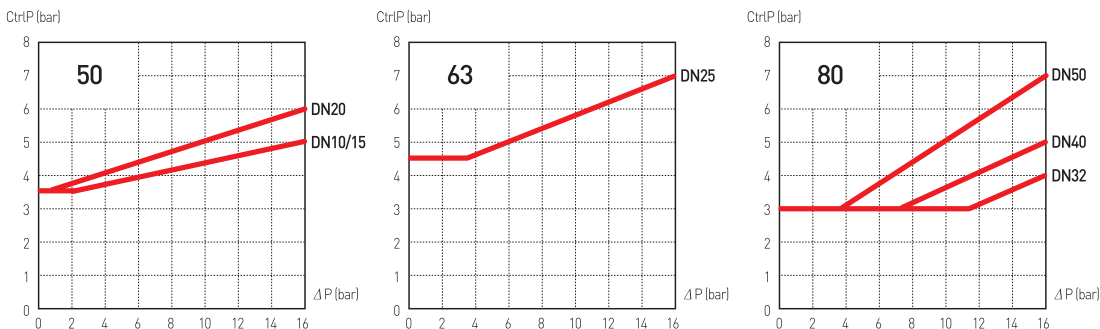

## Flow Charts

Valve Open

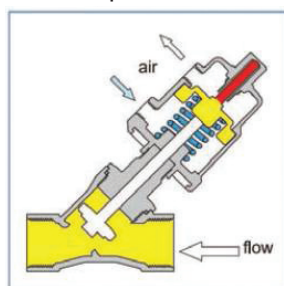

Valve Closed

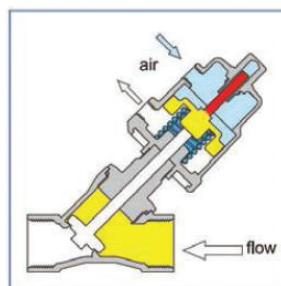

# SERIES PA - NORMALLY CLOSED VALVES - FLOW DIRECTION UNDER SEAT ANTI WATER HAMMER CONSTRUCTION

Model Numbers Shown are BSP threads



## 304 Stainless Steel Actuators with 304 Stainless Steel Bodies

Size	Port size	Orifice (mm)	Actuator (mm)	Kv (m <sup>3</sup> /h)	Operating Pressure Differential		Pilot Control Pressure Range		Model Number	Net Weight kgs
					Bar	PSI	Bar	PSI		
DN10	3/8"	13	50	4.7	0-16	0-232	4.5-10	66-145	PA10SAG3S050S	1.01
DN15	1/2"	13	50	4.7	0-16	0-232	4.5-10	66-145	PA15SAG4S050S	1.03
DN20	3/4"	18	50	9.5	0-10	0-145	4.5-10	66-145	PA20SAG5S050S	1.06
DN25	1"	24	63	18.1	0-8	0-116	4.5-10	66-145	PA25SAG6S063S	2.05
DN32	1-1/4"	31	80	23.1	0-11	0-160	4-10	58-145	PA32SAG7S080S	3.82
DN40	1-1/2"	35	80	32.9	0-8	0-116	4-10	58-145	PA40SAG8S080S	4.07
			100	32.9	0-16	0-232	4-10	58-145	PA40SAG8S100S	4.61
DN50	2"	45	100	52.8	0-9	0-131	4-10	58-145	PA50SAG9S100S	5.16

For NPT porting, change "G" to "N" in 7<sup>th</sup> position

To obtain Cv multiply Kv by 1.16

To obtain lbs., multiply kgs by 2.2

## 304 Stainless Steel Actuators with 316L Stainless Steel Bodies

Size	Port size	Orifice (mm)	Actuator (mm)	Kv (m <sup>3</sup> /h)	Operating Pressure Differential		Pilot Control Pressure Range		Model Number	Net Weight kgs
					Bar	PSI	Bar	PSI		
DN10	3/8"	13	50	4.7	0-16	0-232	4.5-10	66-145	PA10SAG3R050S	1.01
DN15	1/2"	13	50	4.7	0-16	0-232	4.5-10	66-145	PA15SAG4R050S	1.03
DN20	3/4"	18	50	9.5	0-10	0-145	4.5-10	66-145	PA20SAG5R050S	1.06
DN25	1"	24	63	18.1	0-8	0-116	4.5-10	66-145	PA25SAG6R063S	2.05
DN32	1-1/4"	31	80	23.1	0-11	0-160	4-10	58-145	PA32SAG7R080S	3.82
DN40	1-1/2"	35	80	32.9	0-8	0-116	4-10	58-145	PA40SAG8R080S	4.07
			100	32.9	0-16	0-232	4-10	58-145	PA40SAG8R100S	4.61
DN50	2"	45	100	52.8	0-9	0-131	4-10	58-145	PA50SAG9R100S	5.16

For NPT porting, change "G" to "N" in 7<sup>th</sup> position

To obtain Cv multiply Kv by 1.16

To obtain lbs., multiply kgs by 2.2

## Aluminum Actuator with 304 Stainless Steel Bodies

Size	Port size	Orifice (mm)	Actuator (mm)	Kv (m <sup>3</sup> /h)	Operating Pressure Differential		Pilot Control Pressure Range		Model Number	Net Weight kgs
					Bar	PSI	Bar	PSI		
DN10	3/8"	13	50	4.7	0-16	0-232	4.5-10	66-145	PA10SAG3S050A	0.75
DN15	1/2"	13	50	4.7	0-16	0-232	4.5-10	66-145	PA15SAG4S050A	0.80
DN20	3/4"	18	50	9.5	0-10	0-145	4.5-10	66-145	PA20SAG5S050A	0.90
DN25	1"	24	63	18.1	0-8	0-116	4.5-10	66-145	PA25SAG6S063A	1.65
DN32	1-1/4"	31	80	23.1	0-11	0-160	4-10	58-145	PA32SAG7S080A	2.80
DN40	1-1/2"	35	80	32.9	0-8	0-116	4-10	58-145	PA40SAG8S080A	3.10
			100	32.9	0-16	0-232	4-10	58-145	PA40SAG8S100A	4.15
DN50	2"	45	100	52.8	0-9	0-131	4-10	58-145	PA50SAG9S100A	4.75

For NPT porting, change "G" to "N" in 7<sup>th</sup> position

To obtain Cv multiply Kv by 1.16

To obtain lbs., multiply kgs by 2.2

# SERIES PA - NORMALLY CLOSED VALVES - FLOW DIRECTION UNDER SEAT ANTI WATER HAMMER CONSTRUCTION

Model Numbers Shown are BSP threads



## Aluminum Actuator with 316L Stainless Steel Bodies

Size	Port size	Orifice (mm)	Actuator (mm)	Kv (m <sup>3</sup> /h)	Operating Pressure Differential		Pilot Control Pressure Range		Model Number	Net Weight kgs
					Bar	PSI	Bar	PSI		
DN10	3/8"	13	50	4.7	0-16	0-232	4.5-10	66-145	PA10SAG3R050A	0.75
DN15	1/2"	13	50	4.7	0-16	0-232	4.5-10	66-145	PA15SAG4R050A	0.80
DN20	3/4"	18	50	9.5	0-10	0-145	4.5-10	66-145	PA20SAG5R050A	0.90
DN25	1"	24	63	18.1	0-8	0-116	4.5-10	66-145	PA25SAG6R063A	1.65
DN32	1-1/4"	31	80	23.1	0-11	0-160	4-10	58-145	PA32SAG7R080A	2.80
			100	32.9	0-8	0-116	4-10	58-145	PA40SAG8R080A	3.10
DN40	1-1/2"	35	100	32.9	0-16	0-232	4-10	58-145	PA40SAG8R100A	4.15
DN50	2"	45	100	52.8	0-9	0-131	4-10	58-145	PA50SAG9R100A	4.75

For NPT porting, change "G" to "N" in 7<sup>th</sup> position

To obtain Cv multiply Kv by 1.16

To obtain lbs., multiply kgs by 2.2

## Control Pressure & Operating Pressure

Charts do not apply for Anti Water Hammer valves. A minimum pressure as noted above is all that is required, up to the maximum listed.

## Flow Charts

Normally Closed Valve

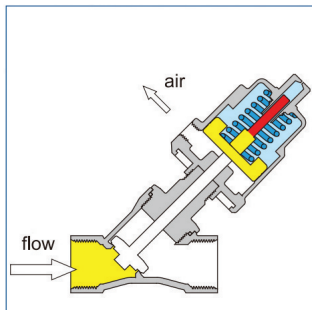

Normally Open Valve

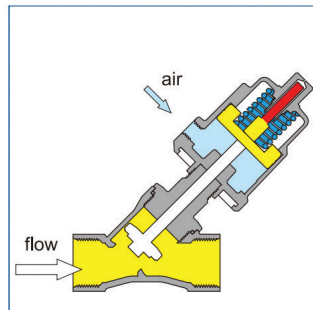

# SERIES PA - NORMALLY OPEN VALVES - FLOW DIRECTION UNDER SEAT

Model Numbers Shown are BSP threads



## 304 Stainless Steel Actuators with 304 Stainless Steel Bodies

Size	Port size	Orifice (mm)	Actuator (mm)	Kv (m <sup>3</sup> /h)	Operating Pressure Differential		Pilot Control Pressure Range		Model Number	Net Weight kgs
					Bar	PSI	Bar	PSI		
DN10	3/8"	13	50	4.7	0-16	0-232	3.5 -10	51-145	PA10S3G3S050S	1.01
DN15	1/2"	13	50	4.7	0-16	0-232	3.5 -10	51-145	PA15S3G4S050S	1.03
DN20	3/4"	18	50	9.5	0-16	0-232	3.5 -10	51-145	PA20S3G5S050S	1.06
DN25	1"	24	63	15.5	0-16	0-232	4.5 -10	66-145	PA25S3G6S063S	2.05
DN32	1-1/4"	31	80	23.1	0-16	0-232	3.0 -10	44-145	PA32S3G7S080S	3.80
DN40	1-1/2"	35	80	31	0-16	0-232	3.0 -10	44-145	PA40S3G8S080S	4.05
DN50	2"	45	80	50	0-16	0-232	3.0 -10	44-145	PA50S3G9S080S	4.62

For NPT porting, change "G" to "N" in 7<sup>th</sup> position

To obtain Cv multiply Kv by 1.16

To obtain lbs., multiply Kgs by 2.2

## 304 Stainless Steel Actuators with 316L Stainless Steel Bodies

Size	Port size	Orifice (mm)	Actuator (mm)	Kv (m <sup>3</sup> /h)	Operating Pressure Differential		Pilot Control Pressure Range		Model Number	Net Weight kgs
					Bar	PSI	Bar	PSI		
DN10	3/8"	13	50	4.7	0-16	0-232	3.5 -10	51-145	PA10S3G3R050S	1.01
DN15	1/2"	13	50	4.7	0-16	0-232	3.5 -10	51-145	PA15S3G4R050S	1.03
DN20	3/4"	18	50	9.5	0-16	0-232	3.5 -10	51-145	PA20S3G5R050S	1.06
DN25	1"	24	63	18.1	0-16	0-232	4.5 -10	66-145	PA25S3G6R063S	2.05
DN32	1-1/4"	31	80	23.1	0-16	0-232	3.0 -10	44-145	PA32S3G7R080S	3.80
DN40	1-1/2"	35	80	31	0-16	0-232	3.0 -10	44-145	PA40S3G8R080S	4.05
DN50	2"	45	80	50	0-16	0-232	3.0 -10	44-145	PA50S3G9R080S	4.62

For NPT porting, change "G" to "N" in 7<sup>th</sup> position

To obtain Cv multiply Kv by 1.16

To obtain lbs., multiply Kgs by 2.2

## Control Pressure & Operating Pressure

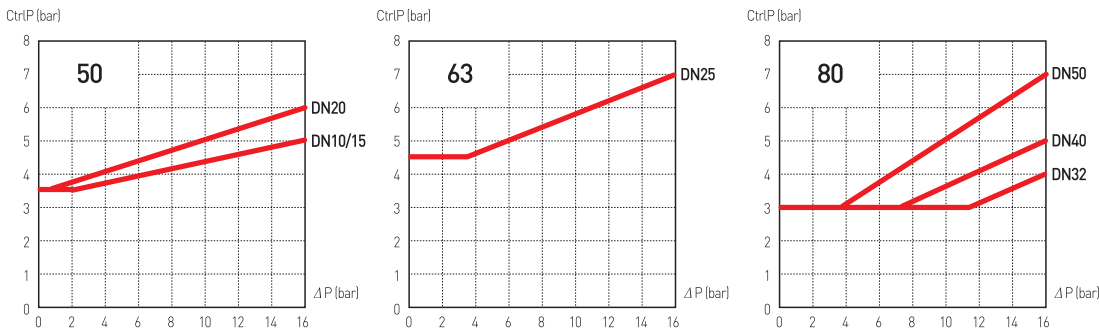

## Flow Charts

Valve Open

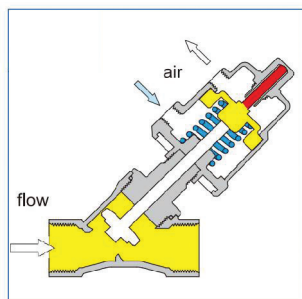

Valve Closed

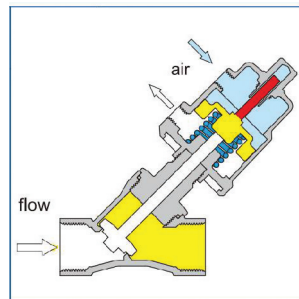

# SERIES PA - NORMALLY OPEN VALVES - FLOW DIRECTION UNDER SEAT

Model Numbers Shown are BSP threads



## Aluminum Actuators with 304 Stainless Steel Bodies

Size	Port size	Orifice (mm)	Actuator (mm)	Kv (m³/h)	Operating Pressure Differential		Pilot Control Pressure Range		Model Number	Net Weight kgs
					Bar	PSI	Bar	PSI		
DN10	3/8"	13	50	4.7	0-16	0-232	3.5 -10	51-145	PA10S3G3S050A	0.88
DN15	1/2"	13	50	4.7	0-16	0-232	3.5 -10	51-145	PA15S3G4S050A	0.90
DN20	3/4"	18	50	9.5	0-16	0-232	3.5 -10	51-145	PA20S3G5S050A	1.00
DN25	1"	24	63	15.5	0-16	0-232	4.5 -10	66-145	PA25S3G6S063A	1.70
DN32	1-1/4"	31	80	23.1	0-16	0-232	3.0 -10	44-145	PA32S3G7S080A	2.90
DN40	1-1/2"	35	80	31	0-16	0-232	3.0 -10	44-145	PA40S3G8S080A	3.19
DN50	2"	45	80	50	0-16	0-232	3.0 -10	44-145	PA50S3G9S080A	3.95

For NPT porting, change "G" to "N" in 7<sup>th</sup> position

To obtain Cv multiply Kv by 1.16

To obtain lbs., multiply Kgs by 2.2

## Aluminum Actuators with 316L Stainless Steel Bodies

Size	Port size	Orifice (mm)	Actuator (mm)	Kv (m³/h)	Operating Pressure Differential		Pilot Control Pressure Range		Model Number	Net Weight kgs
					Bar	PSI	Bar	PSI		
DN10	3/8"	13	50	4.7	0-16	0-232	3.5 -10	51-145	PA10S3G3R050A	0.88
DN15	1/2"	13	50	4.7	0-16	0-232	3.5 -10	51-145	PA15S3G4R050A	0.90
DN20	3/4"	18	50	9.5	0-16	0-232	3.5 -10	51-145	PA20S3G5R050A	1.01
DN25	1"	24	63	15.5	0-16	0-232	4.5 -10	66-145	PA25S3G6R063A	1.70
DN32	1-1/4"	31	80	23.1	0-16	0-232	3.0 -10	44-145	PA32S3G7R080A	2.91
DN40	1-1/2"	35	80	31	0-16	0-232	3.0 -10	44-145	PA40S3G8R080A	3.20
DN50	2"	45	80	50	0-16	0-232	3.0 -10	44-145	PA50S3G9R080A	3.98

For NPT porting, change "G" to "N" in 7<sup>th</sup> position

To obtain Cv multiply Kv by 1.16

To obtain lbs., multiply Kgs by 2.2

## Control Pressure & Operating Pressure

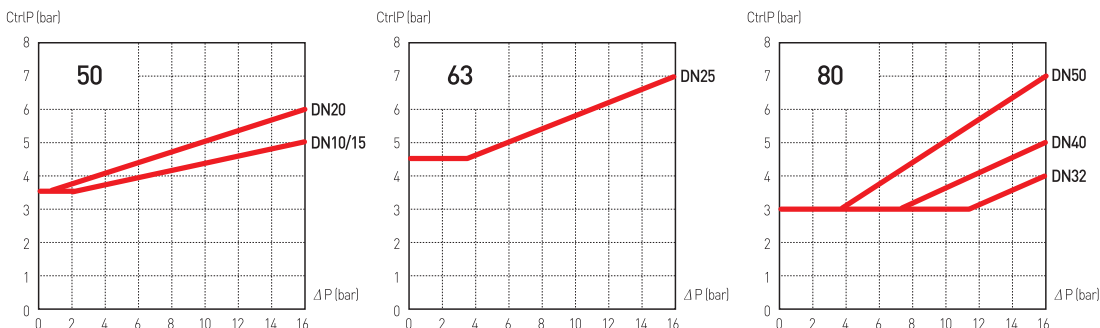



# SERIES PA - COMPACT DESIGN NORMALLY CLOSED VALVES FLOW DIRECTION OVER SEAT

Media Temperature -10~100°C  
Model Numbers Shown are BSP threads



## 304 Stainless Steel Actuators with 304 Stainless Steel Bodies

Size	Port size	Orifice (mm)	Actuator (mm)	Kv (m³/h)	Operating Pressure Differential		Pilot Control Pressure Range		Model Number	Net Weight kgs
					Bar	PSI	Bar	PSI		
DN10	3/8"	13	32	4.7	0-16	0-232	4.5-6	66-87	PA10C3G3S032S	0.58
DN15	1/2"	13	32	4.7	0-16	0-232	4.5-6	66-87	PA15C3G4S032S	0.60
DN20	3/4"	15	32	5.4	0-14	0-203	4.5-6	66-87	PA20C3G5S032S	0.65

## 304 Stainless Steel Actuators with 316L Stainless Steel Bodies

Size	Port size	Orifice (mm)	Actuator (mm)	Kv (m³/h)	Operating Pressure Differential		Pilot Control Pressure Range		Model Number	Net Weight kgs
					Bar	PSI	Bar	PSI		
DN10	3/8"	13	32	4.7	0-16	0-232	4.5-6	66-87	PA10C3G3R032S	0.58
DN15	1/2"	13	32	4.7	0-16	0-232	4.5-6	66-87	PA15C3G4R032S	0.60
DN20	3/4"	15	32	5.4	0-14	0-203	4.5-6	66-87	PA20C3G5R032S	0.65

# SERIES PA - COMPACT DESIGN NORMALLY CLOSED VALVES FLOW DIRECTION OVER SEAT

Media Temperature -10~180°C  
Model Numbers Shown are BSP threads

## 304 Stainless Steel Actuators with 304 Stainless Steel Bodies

Size	Port size	Orifice (mm)	Actuator (mm)	Kv (m³/h)	Operating Pressure Differential		Pilot Control Pressure Range		Model Number	Net Weight kgs
					Bar	PSI	Bar	PSI		
DN10	3/8"	13	32	4.7	0-16	0-232	4.5-6	66-87	PA10C1G3S032S	0.63
DN15	1/2"	13	32	4.7	0-16	0-232	4.5-6	66-87	PA15C1G4S032S	0.65
DN20	3/4"	15	32	5.4	0-14	0-203	4.5-6	66-87	PA20C1G5S032S	0.71

## 304 Stainless Steel Actuators with 316L Stainless Steel Bodies

Size	Port size	Orifice (mm)	Actuator (mm)	Kv (m³/h)	Operating Pressure Differential		Pilot Control Pressure Range		Model Number	Net Weight kgs
					Bar	PSI	Bar	PSI		
DN10	3/8"	13	32	4.7	0-16	0-232	4.5-6	66-87	PA10C1G3R032S	0.63
DN15	1/2"	13	32	4.7	0-16	0-232	4.5-6	66-87	PA15C1G4R032S	0.65
DN20	3/4"	15	32	5.4	0-14	0-203	4.5-6	66-87	PA20C1G5R032S	0.71

## Control Pressure & Operating Pressure Charts

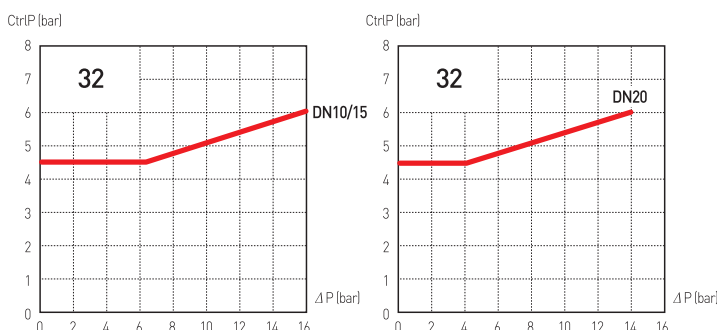

## Flow Charts

Normally Closed Valve

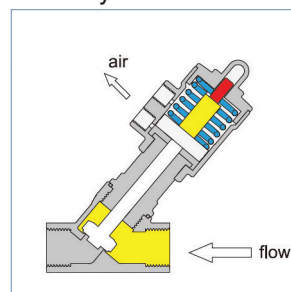

Normally Open Valve

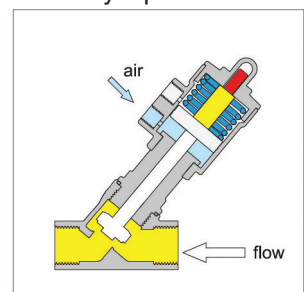

# SERIES PA - COMPACT DESIGN NORMALLY CLOSED VALVES FLOW DIRECTION UNDER SEAT

Media Temperature -10~100°C  
Model Numbers Shown are BSP threads



## 304 Stainless Steel Actuators with 304 Stainless Steel Bodies

Size	Port size	Orifice (mm)	Actuator (mm)	Kv (m³/h)	Operating Pressure Differential		Pilot Control Pressure Range		Model Number	Net Weight kgs
					Bar	PSI	Bar	PSI		
DN10	3/8"	13	32	4.7	0-6	0-87	5-6	73-87	PA10C4G3S032S	0.58
DN15	1/2"	13	32	4.7	0-6	0-87	5-6	73-87	PA15C4G4S032S	0.60
DN20	3/4"	15	32	5.4	0-4	0-58	5-6	73-87	PA20C4G5S032S	0.65

## 304 Stainless Steel Actuators with 316L Stainless Steel Bodies

Size	Port size	Orifice (mm)	Actuator (mm)	Kv (m³/h)	Operating Pressure Differential		Pilot Control Pressure Range		Model Number	Net Weight kgs
					Bar	PSI	Bar	PSI		
DN10	3/8"	13	32	4.7	0-6	0-87	5-6	73-87	PA10C4G3R032S	0.58
DN15	1/2"	13	32	4.7	0-6	0-87	5-6	73-87	PA15C4G4R032S	0.60
DN20	3/4"	15	32	5.4	0-4	0-58	5-6	73-87	PA20C4G5R032S	0.65

# SERIES PA - COMPACT DESIGN NORMALLY CLOSED VALVES FLOW DIRECTION UNDER SEAT Media Temperature -10~180°C

Model Numbers Shown are BSP threads

## 304 Stainless Steel Actuators with 304 Stainless Steel Bodies

Size	Port size	Orifice (mm)	Actuator (mm)	Kv (m³/h)	Operating Pressure Differential		Pilot Control Pressure Range		Model Number	Net Weight kgs
					Bar	PSI	Bar	PSI		
DN10	3/8"	13	32	4.7	0-6	0-87	5-6	73-87	PA10C2G3S032S	0.63
DN15	1/2"	13	32	4.7	0-6	0-87	5-6	73-87	PA15C2G4S032S	0.65
DN20	3/4"	15	32	5.4	0-4	0-58	5-6	73-87	PA20C2G5S032S	0.71

## 304 Stainless Steel Actuators with 316L Stainless Steel Bodies

Size	Port size	Orifice (mm)	Actuator (mm)	Kv (m³/h)	Operating Pressure Differential		Pilot Control Pressure Range		Model Number	Net Weight kgs
					Bar	PSI	Bar	PSI		
DN10	3/8"	13	32	4.7	0-6	0-87	5-6	73-87	PA10C2G3R032S	0.63
DN15	1/2"	13	32	4.7	0-6	0-87	5-6	73-87	PA15C2G4R032S	0.65
DN20	3/4"	15	32	5.4	0-4	0-58	5-6	73-87	PA20C2G5R032S	0.71

For all Compact Design valves on pages 10-11 the following applies:

For NPT porting, change "G" to "N" in 7<sup>th</sup> position

To obtain Cv multiply Kv by 1.16

To obtain lbs., multiply kgs by 2.2

## Control Pressure & Operating Pressure Charts

Charts do not apply for valves with flow direction under the seat. A minimum pressure as noted above is all that is required, up to the maximum listed.

## Flow Charts

Normally Closed Valve

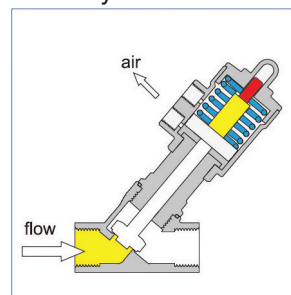

Normally Open Valve

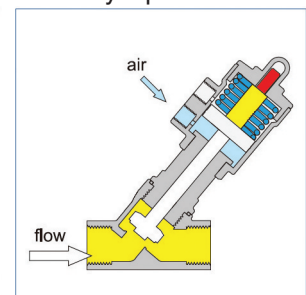

# SERIES PA - COMPACT DESIGN NORMALLY OPEN VALVES FLOW DIRECTION OVER SEAT

Media Temperature -10~100°C  
Model Numbers Shown are BSP threads



## 304 Stainless Steel Actuators with 304 Stainless Steel Bodies

Size	Port size	Orifice (mm)	Actuator (mm)	Kv (m³/h)	Operating Pressure Differential		Pilot Control Pressure Range		Model Number	Net Weight kgs
					Bar	PSI	Bar	PSI		
DN10	3/8"	13	32	4.7	0-16	0-232	5 -10	72.5-145	PA10J3G3S032S	0.58
DN15	1/2"	13	32	4.7	0-16	0-232	5 -10	72.5-145	PA15J3G4S032S	0.6
DN20	3/4"	15	32	5.4	0-10	0-145	5 -10	72.5-145	PA20J3G5S032S	0.65

## 304 Stainless Steel Actuators with 316L Stainless Steel Bodies

Size	Port size	Orifice (mm)	Actuator (mm)	Kv (m³/h)	Operating Pressure Differential		Pilot Control Pressure Range		Model Number	Net Weight kgs
					Bar	PSI	Bar	PSI		
DN10	3/8"	13	32	4.7	0-16	0-232	5 -10	72.5-145	PA10J3G3R032S	0.58
DN15	1/2"	13	32	4.7	0-16	0-232	5 -10	72.5-145	PA15J3G4R032S	0.60
DN20	3/4"	15	32	5.4	0-10	0-145	5 -10	72.5-145	PA20J3G5R032S	0.65

# SERIES PA - COMPACT DESIGN NORMALLY OPEN VALVES FLOW DIRECTION OVER SEAT

Media Temperature -10~180°C  
Model Numbers Shown are BSP threads

## 304 Stainless Steel Actuators with 304 Stainless Steel Bodies

Size	Port size	Orifice (mm)	Actuator (mm)	Kv (m³/h)	Operating Pressure Differential		Pilot Control Pressure Range		Model Number	Net Weight kgs
					Bar	PSI	Bar	PSI		
DN10	3/8"	13	32	4.7	0-16	0-232	5-10	72.5-145	PA10J1G3S032S	0.63
DN15	1/2"	13	32	4.7	0-16	0-232	5-10	72.5-145	PA15J1G4S032S	0.65
DN20	3/4"	15	32	5.4	0-10	0-145	5-10	72.5-145	PA20J1G5S032S	0.71

## 304 Stainless Steel Actuators with 316L Stainless Steel Bodies

Size	Port size	Orifice (mm)	Actuator (mm)	Kv (m³/h)	Operating Pressure Differential		Pilot Control Pressure Range		Model Number	Net Weight kgs
					Bar	PSI	Bar	PSI		
DN10	3/8"	13	32	4.7	0-16	0-232	5-10	72.5-145	PA10J1G3R032S	0.63
DN15	1/2"	13	32	4.7	0-16	0-232	5-10	72.5-145	PA15J1G4R032S	0.65
DN20	3/4"	15	32	5.4	0-10	0-145	5-10	72.5-145	PA20J1G5R032S	0.71

## Control Pressure & Operating Pressure Charts

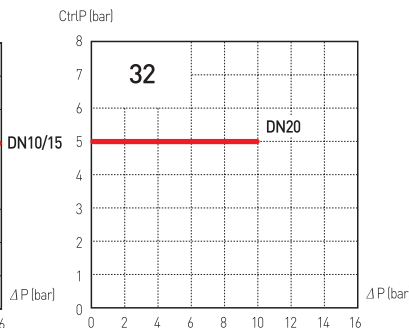
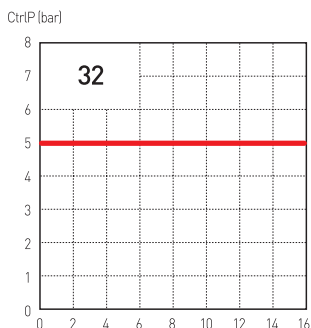

## Flow Charts

### Normally Open Valve

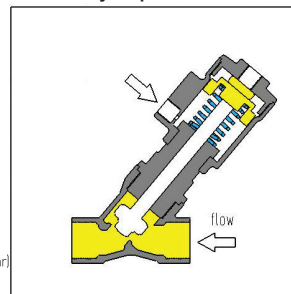

### Normally Closed Valve

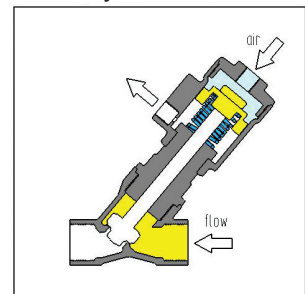

# SERIES PA - COMPACT DESIGN NORMALLY OPEN VALVES FLOW DIRECTION UNDER SEAT



Media Temperature -10~100°C  
Model Numbers Shown are BSP threads

## 304 Stainless Steel Actuators with 304 Stainless Steel Bodies

Size	Port size	Orifice (mm)	Actuator (mm)	Kv (m³/h)	Operating Pressure Differential		Pilot Control Pressure Range		Model Number	Net Weight kgs
					Bar	PSI	Bar	PSI		
DN10	3/8"	13	32	4.7	0-6	0-87	4 -10	58-145	PA10J4G3S032S	0.58
DN15	1/2"	13	32	4.7	0-6	0-87	4 -10	58-145	PA15J4G4S032S	0.60
DN20	3/4"	15	32	5.4	0-4	0-87	4 -10	58-145	PA20J4G5S032S	0.65

## 304 Stainless Steel Actuators with 316L Stainless Steel Bodies

Size	Port size	Orifice (mm)	Actuator (mm)	Kv (m³/h)	Operating Pressure Differential		Pilot Control Pressure Range		Model Number	Net Weight kgs
					Bar	PSI	Bar	PSI		
DN10	3/8"	13	32	4.7	0-6	0-87	4 -10	58-145	PA10J4G3R032S	0.58
DN15	1/2"	13	32	4.7	0-6	0-87	4 -10	58-145	PA15J4G4R032S	0.60
DN20	3/4"	15	32	5.4	0-4	0-87	4 -10	58-145	PA20J4G5R032S	0.65

# SERIES PA - COMPACT DESIGN NORMALLY OPEN VALVES FLOW DIRECTION UNDER SEAT Media Temperature -10~180°C

Model Numbers Shown are BSP threads

## 304 Stainless Steel Actuators with 304 Stainless Steel Bodies

Size	Port size	Orifice (mm)	Actuator (mm)	Kv (m³/h)	Operating Pressure Differential		Pilot Control Pressure Range		Model Number	Net Weight kgs
					Bar	PSI	Bar	PSI		
DN10	3/8"	13	32	4.7	0-6	0-87	4 -10	58-145	PA10J2G3S032S	0.63
DN15	1/2"	13	32	4.7	0-6	0-87	4 -10	58-145	PA15J2G4S032S	0.65
DN20	3/4"	15	32	5.4	0-4	0-87	4 -10	58-145	PA20J2G5S032S	0.71

## 304 Stainless Steel Actuators with 316L Stainless Steel Bodies

Size	Port size	Orifice (mm)	Actuator (mm)	Kv (m³/h)	Operating Pressure Differential		Pilot Control Pressure Range		Model Number	Net Weight kgs
					Bar	PSI	Bar	PSI		
DN10	3/8"	13	32	4.7	0-6	0-87	4 -10	58-145	PA10J2G3R032S	0.63
DN15	1/2"	13	32	4.7	0-6	0-87	4 -10	58-145	PA15J2G4R032S	0.65
DN20	3/4"	15	32	5.4	0-4	0-87	4 -10	58-145	PA20J2G5R032S	0.71

## Control Pressure & Operating Pressure Charts

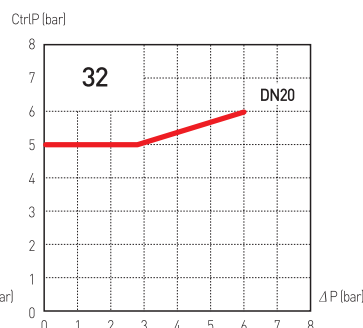
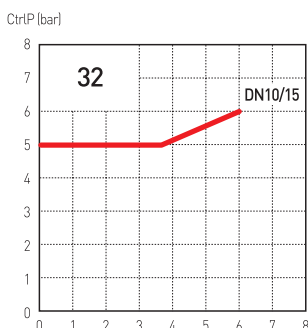

## Flow Charts

### Normally Open Valve

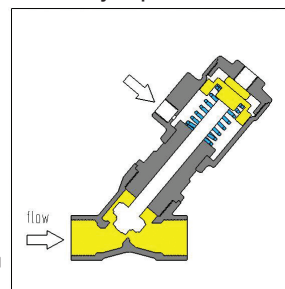

### Normally Closed Valve

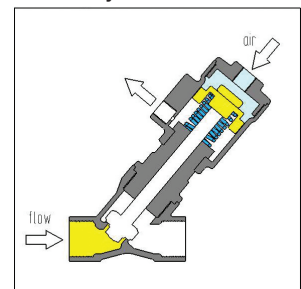

# SERIES PA Drawings and Dimensions

## Stainless Steel Actuators

Sizes 40, 50, 63, 80, 100 mm

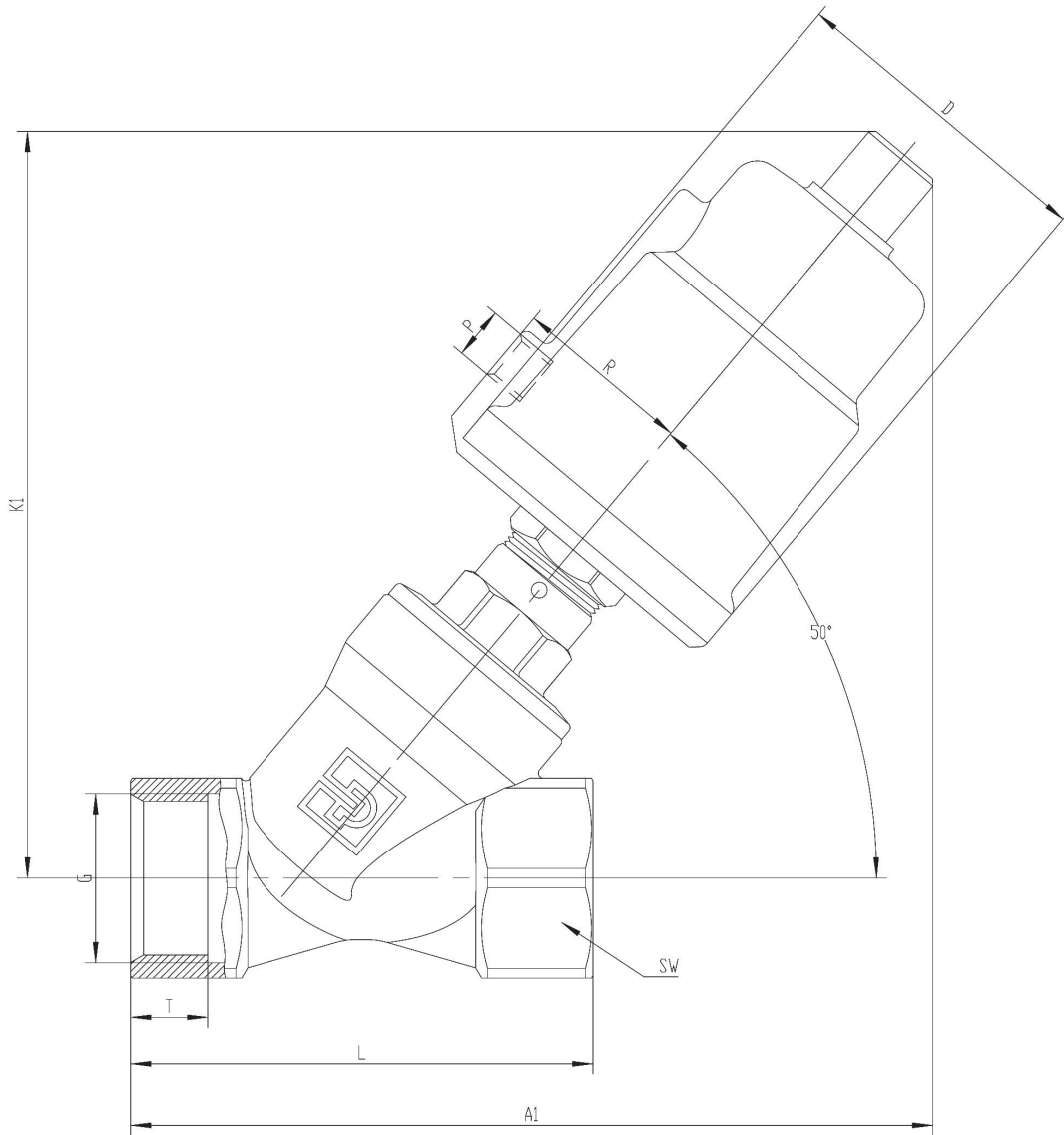

Type	Actuator	D	R	P	K1	A1	G	L	T	SW	
DN10	40	50.5	27	G1/8	116	121	G3/8	60	10	22	hexagon
	50	62	34	G1/8	130	133	G3/8	60	10	22	hexagon
DN15	40	50.5	27	G1/8	118	124	G1/2	65	11.5	25	hexagon
	50	62	34	G1/8	131	135	G1/2	65	11.5	25	hexagon
DN20	50	62	34	G1/8	134	141	G3/4	75	14	31	hexagon
DN25	50	62	34	G1/8	141	153	G1	90	15	39	hexagon
	63	77	41.5	G1/8	164	175	G1	90	15	39	hexagon
DN32	63	77	41.5	G1/8	170	188	G1-1/4	110	18	50	octagon
	80	98	52	G1/4	184	205	G1-1/4	110	18	50	octagon
	63	77	41.5	G1/8	181	201	G1-1/2	120	18	56	octagon
DN40	80	98	52	G1/4	195	217	G1-1/2	120	18	56	octagon
	100	121	63	G1/4	213	235	G1-1/2	120	18	56	octagon
DN50	63	77	41.5	G1/8	189	216	G2	150	22	68	octagon
	80	98	52	G1/4	203	233	G2	150	22	68	octagon
	100	121	63	G1/4	221	250	G2	150	22	68	octagon
DN65	100	121	63	G1/4	248	285	G2-1/2	180	25	85	octagon



# SERIES PA Drawings and Dimensions



## Aluminum Actuators

Sizes 50, 63, 80, 100 mm

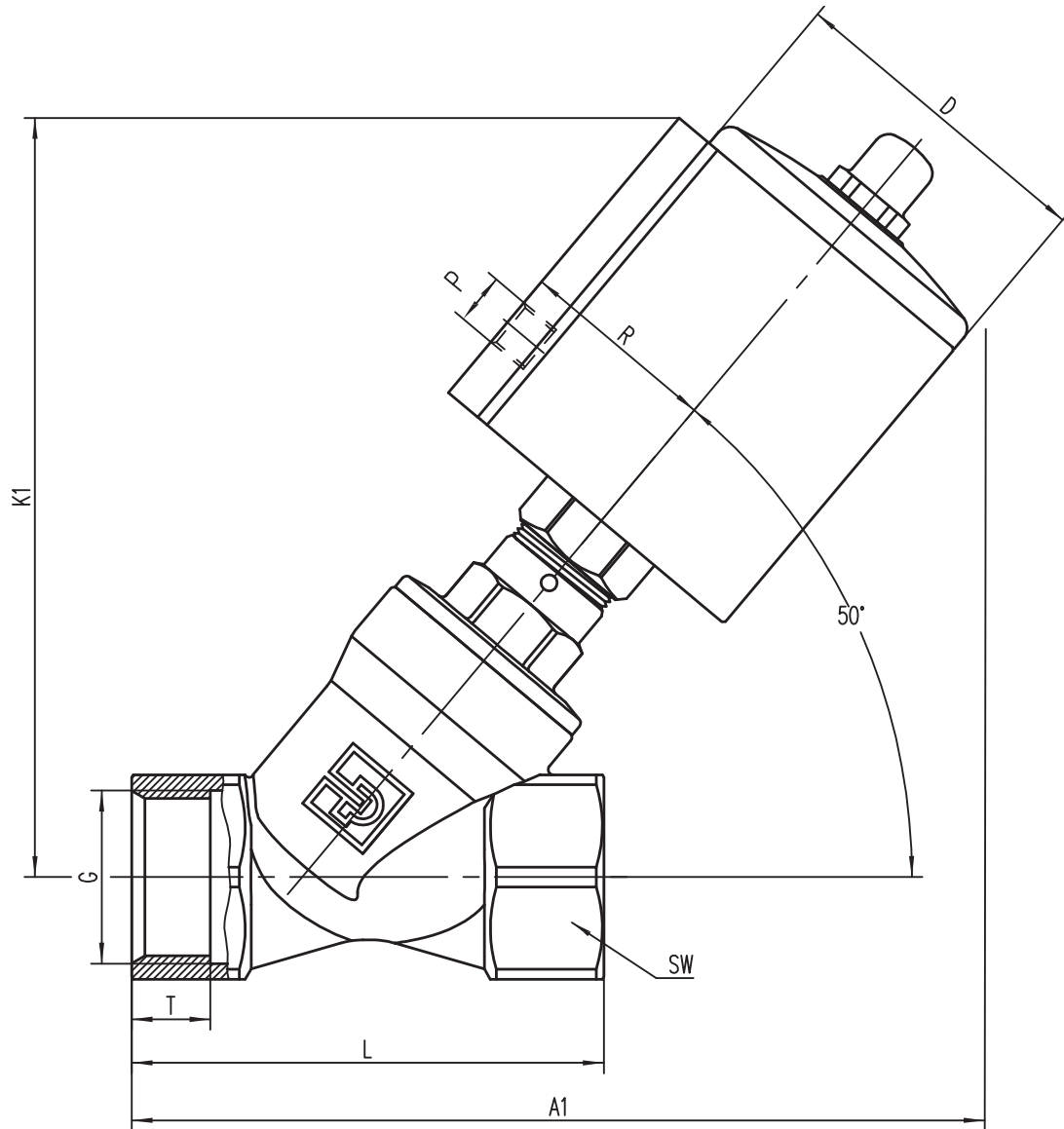

Type	Actuator	D	R	P	K1	A1	G	L	T	SW	
DN10	50	61	38	G1/8	132	141	G3/8	60	10	22	hexagon
DN15	50	61	38	G1/8	133	144	G1/2	65	11.5	25	hexagon
DN20	50	61	38	G1/8	136	150	G3/4	75	14	31	hexagon
DN25	50	61	38	G1/8	144	162	G1	90	15	39	hexagon
	63	75	45	G1/8	167	183	G1	90	15	39	hexagon
DN32	63	75	45	G1/8	173	196	G1-1/4	110	18	50	octagon
	80	94	54	G1/4	192	214	G1-1/4	110	18	50	octagon
DN40	63	75	45	G1/8	184	209	G1-1/2	120	18	56	octagon
	80	94	54	G1/4	203	226	G1-1/2	120	18	56	octagon
	100	115	64	G1/4	223	245	G1-1/2	120	18	56	octagon
DN50	63	75	45	G1/8	192	224	G2	150	22	68	octagon
	80	94	54	G1/4	211	242	G2	150	22	68	octagon
	100	115	64	G1/4	231	260	G2	150	22	68	octagon
DN65	100	115	64	G1/4	257	294	G2-1/2	180	25	85	octagon

# SERIES PA Drawings and Dimensions

## Stainless Steel Actuators

Sizes 32 mm

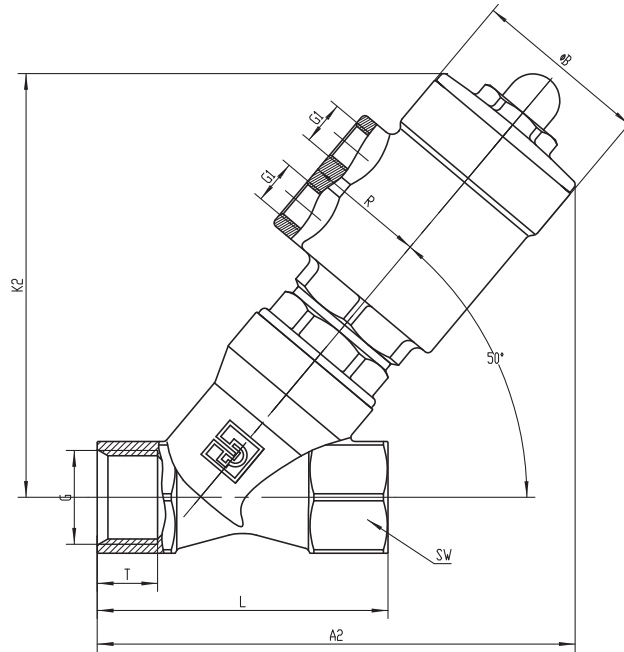

Normally Closed

Type	Actuator	ΦB	R	G1	K2		A2		G	L	T	SW	
					F32-H	F32-L	F32-H	F32-L				hexagon	hexagon
DN10	32	39.6	27	G1/8	107	94	117	106	G3/8	60	10	22	hexagon
DN15	32	39.6	27	G1/8	109	96	119	108	G1/2	65	11.5	25	hexagon
DN20	32	39.6	27	G1/8	112	100	126	115	G3/4	75	14	31	hexagon

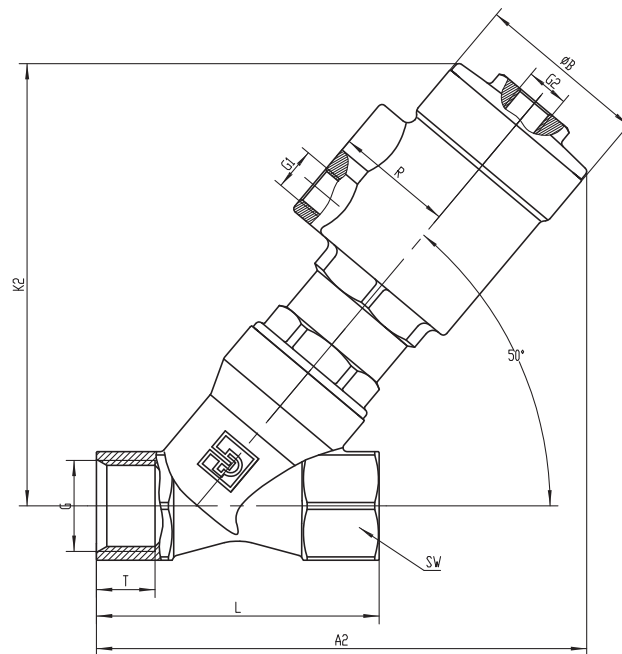

Normally Open

Type	Actuator	ΦB	R	G1	G2	K2		A2		G	L	T	SW	
						F32-H	F32-L	F32-H	F32-L				hexagon	hexagon
DN10	32	39.6	27	G1/8	G1/8	107	94	117	106	G3/8	60	10	22	hexagon
DN15	32	39.6	27	G1/8	G1/8	109	96	119	108	G1/2	65	11.5	25	hexagon
DN20	32	39.6	27	G1/8	G1/8	112	100	126	115	G3/4	75	14	31	hexagon

# SERIES PA Drawings and Dimensions Weld Connections

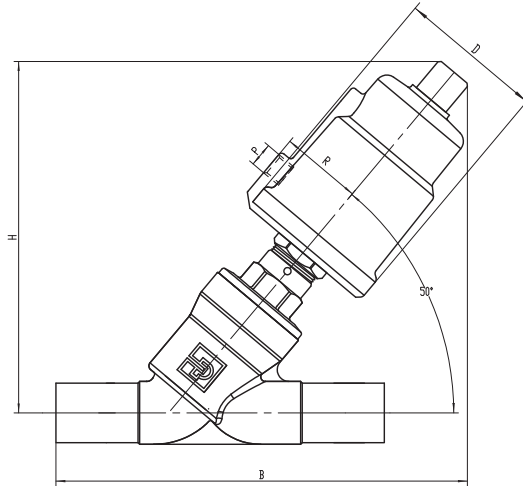

Type	Actuator	D	R	P	ISO1127/4200		DIN11850.1/2/3		SMS3008/ASME BPE	
					H	B	H	B	H	B
DN10	40	50.5	27	G1/8	125	141	125	141	-	-
	50	62	34	G1/8	138	152	138	152	-	-
DN15	40	50.5	27	G1/8	125	141	125	141	125	141
	50	62	34	G1/8	139	153	139	153	139	153
DN20	50	62	34	G1/8	144	162	144	162	144	162
DN25	50	62	34	G1/8	151	172	151	172	151	172
	63	77	41.5	G1/8	172	190	172	190	174	192
DN32	63	77	41.5	G1/8	185	203	185	203	-	-
	80	98	52	G1/4	196	217	196	217	-	-
DN40	63	77	41.5	G1/8	196	216	196	216	194	214
	80	98	52	G1/4	207	230	207	230	205	229
	100	121	63	G1/4	222	248	222	248	221	247
DN50	63	77	41.5	G1/8	205	227	205	227	205	227
	80	98	52	G1/4	216	242	216	242	216	242
	100	121	63	G1/4	232	259	232	259	232	259
DN65	100	121	63	G1/4	257	288	257	288	257	288

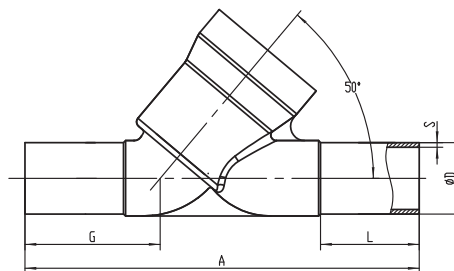

Body size-Welded (mm)

Type	A	G	L	ISO1127/4200		DIN11850.1		DIN11850.2		DIN11850.3		SMS 3008		ASME BPE	
				ΦD	ΦS	ΦD	ΦS	ΦD	ΦS	ΦD	ΦS	ΦD	ΦS	ΦD	ΦS
DN10	100	34	20	17.2	1.6	12	1	13	1.5	14	2	-	-	-	-
DN15	100	34	20	21.3	1.6	18	1	19	1.5	20	2	12	1	12.7	1.65
DN20	115	39	25	26.9	1.6	22	1	23	1.5	24	2	18	1	19.05	1.65
DN25	130	43	26	33.7	2	28	1	29	1.5	30	2	25	1.2	25.4	1.65
DN32	145	45	26	42.4	2	34	1	35	1.5	36	2	-	-	-	-
DN40	160	49	26	48.3	2	40	1	41	1.5	42	2	38	1.2	38.1	1.65
DN50	175	52	26	60.3	2	52	1	53	1.5	54	2	51	1.2	50.8	1.65
DN65	210	60	30	76.1	2	-	-	70	1.5	-	-	63.5	1.6	63.5	1.65

# SERIES PA Drawings and Dimensions

## Clamp Connections

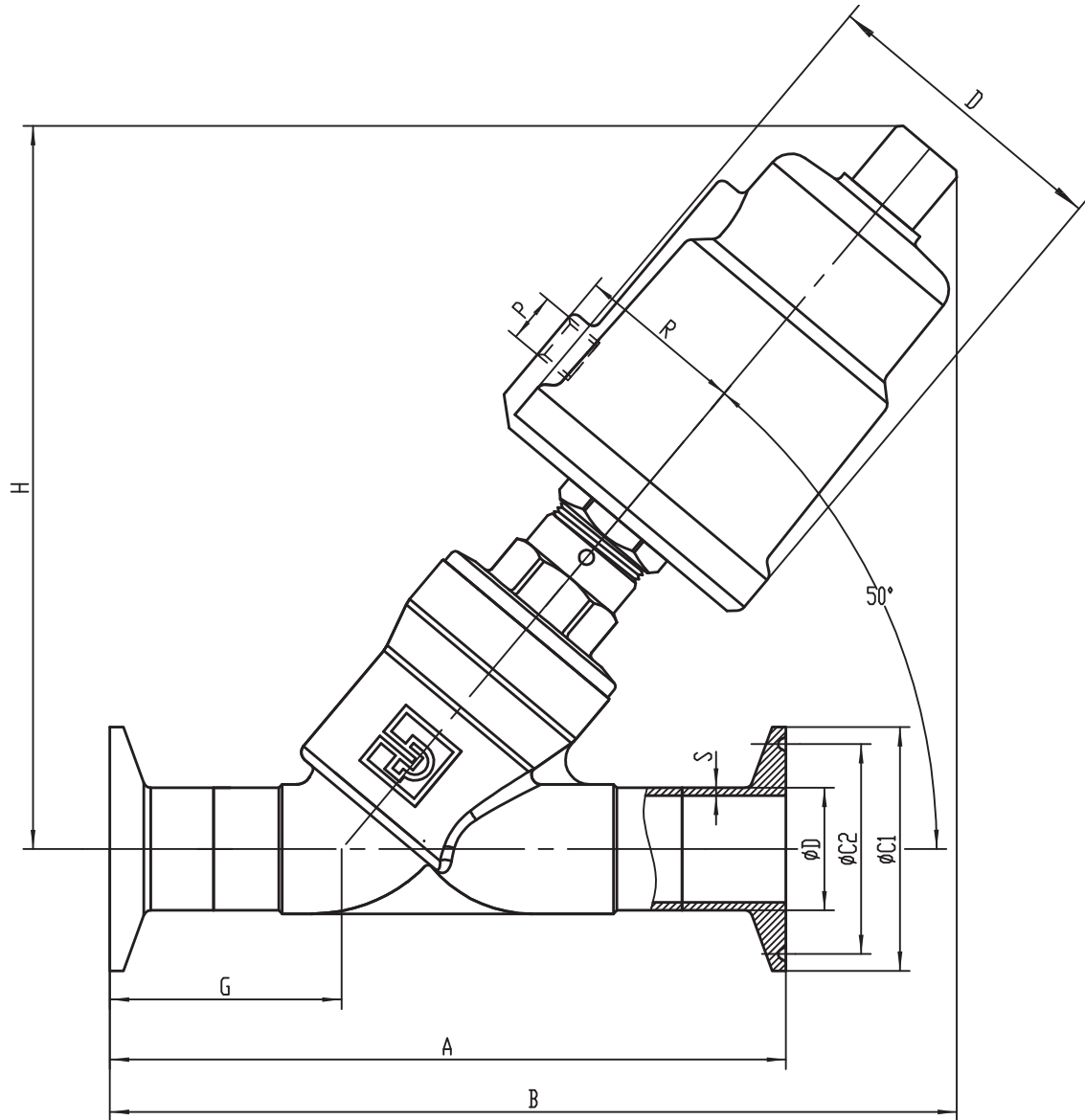

Type	Actuator	ASME BPE										
		mm										
		D	R	P	H	B	A	G	$\phi C1$	$\phi C2$	$\phi D$	S
DN15	40	50.5	27	G1/8	119	136	101.6	34.8	25.2	20.2	12.7	1.65
	50	62	34	G1/8	132	148	101.6	34.8	25.2	20.2	12.7	1.65
DN20	50	62	34	G1/8	137	150	114.3	32.5	25.2	20.2	19.05	1.65
DN25	50	62	34	G1/8	146	160	114.3	35.15	50.5	43.5	25.4	1.65
	63	77	41.5	G1/8	169	182	114.3	35.15	50.5	43.5	25.4	1.65
DN40	63	77	41.5	G1/8	189	202	139.7	38.85	50.5	43.5	38.1	1.65
	80	98	52	G1/4	202	219	139.7	38.85	50.5	43.5	38.1	1.65
	100	121	63	G1/4	221	236	139.7	38.85	50.5	43.5	38.1	1.65
DN50	63	77	41.5	G1/8	200	216	158.8	43.9	64	56.5	50.8	1.65
	80	98	52	G1/4	213	233	158.8	43.9	64	56.5	50.8	1.65
	100	121	63	G1/4	231	251	158.8	43.9	64	56.5	50.8	1.65

# SERIES PA Drawings and Dimensions

## Flange Connections

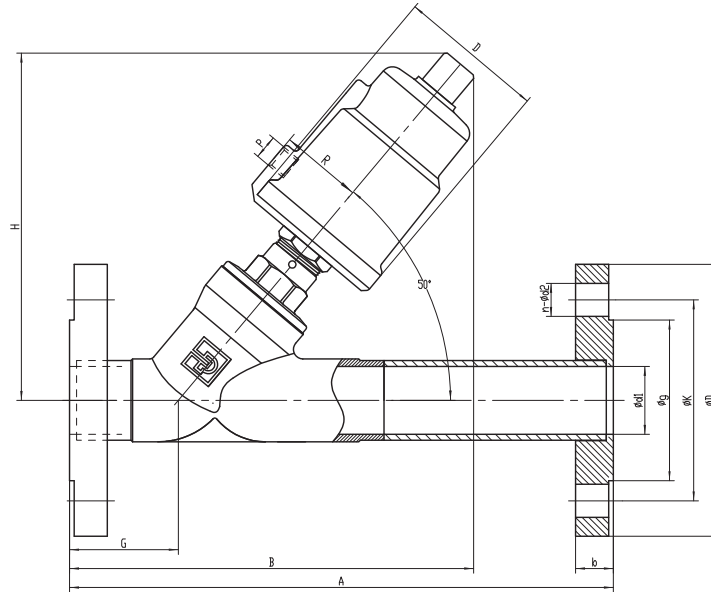

### Flange connection (ANSI Class 150lb)

Type	Actuator	D (mm)	R (mm)	P	H (mm)	A (mm)	B (mm)	G (mm)	$\phi$ d1 (mm)	n	$\phi$ d2 (mm)	$\phi$ g (mm)	$\phi$ K (mm)	$\phi$ D (mm)	b (mm)
DN15	40	50.5	27	G1/8	124	195	144	37	16.4	4	15.9	34.9	60.3	88.9	11.1
	50	62	34	G1/8	138	195	155	37	16.4	4	15.9	34.9	60.3	88.9	11.1
DN20	50	62	34	G1/8	144	218	165	42	22.6	4	15.9	42.9	69.8	98.4	12.7
	63	77	41.5	G1/8	171	241	192	46	28.7	4	15.9	50.8	79.4	107.9	14.3
DN25	50	62	34	G1/8	149	241	173	46	28.7	4	15.9	50.8	79.4	107.9	14.3
	63	77	41.5	G1/8	185	258	206	48	37	4	15.9	63.5	88.9	117.5	15.9
DN32	80	98	52	G1/4	196	258	220	48	37	4	15.9	63.5	88.9	117.5	15.9
	63	77	41.5	G1/8	196	283	218	52	42.6	4	15.9	73	98.4	127	17.5
DN40	80	98	52	G1/4	207	283	233	52	42.6	4	15.9	73	98.4	127	17.5
	100	121	63	G1/4	222	283	251	52	42.6	4	15.9	73	98.4	127	17.5
DN50	63	77	41.5	G1/8	204	300	228	55	53.4	4	19.05	92.1	120.6	152.4	19.1
	80	98	52	G1/4	215	300	243	55	53.4	4	19.05	92.1	120.6	152.4	19.1
	100	121	63	G1/4	230	300	260	55	53.4	4	19.05	92.1	120.6	152.4	19.1

### Flange connection (DIN 16bar)

DN10	40	50.5	27	G1/8	124	210	144	37	12.3	4	14	40	60	90	14
	50	62	34	G1/8	138	210	155	37	12.3	4	14	40	60	90	14
DN15	40	50.5	27	G1/8	124	210	144	37	16.4	4	14	45	65	95	14
	50	62	34	G1/8	138	210	155	37	16.4	4	14	45	65	95	14
DN20	50	62	34	G1/8	144	230	165	42	22.6	4	14	58	75	105	16
	63	77	41.5	G1/8	171	230	192	46	28.7	4	14	68	85	115	16
DN25	50	62	34	G1/8	149	230	173	46	28.7	4	14	68	85	115	16
	63	77	41.5	G1/8	185	260	206	48	37	4	18	78	100	140	16
DN32	80	98	52	G1/4	196	260	220	48	37	4	18	78	100	140	16
	63	77	41.5	G1/8	196	260	218	52	42.6	4	18	88	110	150	16
DN40	80	98	52	G1/4	207	260	233	52	42.6	4	18	88	110	150	16
	100	121	63	G1/4	222	260	251	52	42.6	4	18	88	110	150	16
DN50	63	77	41.5	G1/8	204	300	228	55	53.4	4	18	102	125	165	18
	80	98	52	G1/4	215	300	243	55	53.4	4	18	102	125	165	18
	100	121	63	G1/4	230	300	260	55	53.4	4	18	102	125	165	18
DN65	100	121	63	G1/4	257	340	291	63	68	4	18	122	145	185	18

### Flange connection (JIS 10K)

DN15	40	50.5	27	G1/8	124	165	144	37	16.4	4	15	51	70	95	12
	50	62	34	G1/8	138	165	155	37	16.4	4	15	51	70	95	12
DN20	50	62	34	G1/8	144	184	165	42	22.6	4	15	56	75	100	14
	63	77	41.5	G1/8	171	196	173	46	28.7	4	19	67	90	125	14
DN25	50	62	34	G1/8	149	196	173	46	28.7	4	19	67	90	125	14
	63	77	41.5	G1/8	185	208	206	48	37	4	19	76	100	135	16
DN32	80	98	52	G1/4	196	208	220	48	37	4	19	76	100	135	16
	63	77	41.5	G1/8	196	235	218	52	42.6	4	19	81	105	140	16
DN40	80	98	52	G1/4	207	235	233	52	42.6	4	19	81	105	140	16
	100	121	63	G1/4	222	235	251	52	42.6	4	19	81	105	140	16
DN50	63	77	41.5	G1/8	204	247	228	55	53.4	4	19	96	120	155	16
	80	98	52	G1/4	215	247	243	55	53.4	4	19	96	120	155	16
	100	121	63	G1/4	230	247	260	55	53.4	4	19	96	120	155	16



# SERIES PA Numbering System



## Angle Body Valve Numbering System

PA	10	S1	G3	S	063S	-
----	----	----	----	---	------	---

0: Parker Actuator(PA)

1: Valve size    2: Valve Type/series    3: Body Thread Standard    4: Body Material    5: Actuator Description    6: Special requirement (Reserved Digit)

10	DN10
15	DN15
20	DN20
25	DN25
32	DN32
40	DN40
50	DN50
65	DN65

S1	NC,flow direction over seat
S2	NO, flow direction over seat
S3	NO, flow direction under seat
SA	NC,flow direction under seat (Anti-Water hammer)
D1	Double acting(without spring)
D2	Double acting(with spring)
D3	Double acting(special type)
C1	NC, Compact type, with flow direction
C2	NC,Compact type, against flow direction
C3	NC,Compact type,with flow direction (100 °C)
C4	NC,Compact type,against flow direction(100 °C)
J1	NO, Compact type, with flow direction
J2	NO, Compact type, against flow direction
J3	NO,Compact type,with flow direction(100 °C)
J4	NO,Compact type,against flow direction(100 °C)

G3	3/8	BSP
G4	1/2	BSP
G5	3/4	BSP
G6	1	BSP
G7	1¼	BSP
G8	1½	BSP
G9	2	BSP
GT	2½	BSP

N3	3/8	NPT
N4	1/2	NPT
N5	3/4	NPT
N6	1	NPT
N7	1¼	NPT
N8	1½	NPT
N9	2	NPT
NT	2½	NPT

T1	1/8	BSPT
T2	1/4	BSPT
T3	3/8	BSPT
T4	1/2	BSPT
T5	3/4	BSPT
T6	1	BSPT
T7	1¼	BSPT
T8	1½	BSPT
T9	2	BSPT
TT	2½	BSPT

S	304SS
R	316L SS
W	without body

Stainless Steel 304	
032S	32mm actuator
040S	40mm actuator
050S	50mm actuator
063S	63mm actuator
080S	80mm actuator
100S	100mm actuator

Aluminum	
040A	40mm actuator
050A	50mm actuator
063A	63mm actuator
080A	80mm actuator
100A	100mm actuator

Note: "With Flow" is the same as flow over the seat.  
"Against Flow" is the same as flow under the seat.

XX	None (witouht body)
WA	Weld type ASME BPE
WS	Weld type SMS 3008
W1	Weld type DIN 11850.1
W2	Weld type DIN 11850.2
W3	Weld type DIN 11850.3
WD	Weld type ISO 1127/47200
CA	CLAMP type ASME/BPE

FA	Flange type ANSI B16.5-2003	150Lb	RF
FD	Flange type DIN 2633	PN16	RF
FA	Flange type JIS B2239-2004	150Lb	RF

# 3 Way Direct Acting Pilot Control Valves

Available as Separate Components



## Features

- Compact Designs
- Brass or Stainless Steel body valves
- NC (normally closed) and NO (normally open) versions
- Broad offering of coils to meet World Wide requirements
- Available in BSP and NPT connections in 1/8" and 1/4" sizes

## Representative Pictures



## Banjo Valve- For Direct Mounting to the ABV



Banjo Valve



Banjo Valve Mounted to ABV

# 3 Way Direct Acting Pilot Control Valves

## Banjo Valve



### Features

Direct Mount to ABV pilot port-(must be BSP thread port)  
 Standard Manual Operator  
 Din Coil Standard, others available

### Technical Specifications

#### Mechanical Characteristics

##### Valve Type

3/2 normally closed solenoid valve

##### Materials

Anodized aluminum body,  
 Stainless steel internals,  
 FKM sealing material

##### Coil Enclosures

DIN,NEMA4 with cable gland connector,Class F Available hazardous Class H coil that meets FM /CSA approvals for Class 1, Div.1 Groups A,B,C,D and Class II , Div.2 Groups E,F,G. Meets EEx m T4 Zone 1.

#### Coil Wattage

4.5 to 5.0 watt depending on voltage

#### Porting

1/8" NPT or G1/8" pressure port. (reference valve number) Banjo bolt G1/8" or G1/4" male thread

#### Mounting

Any position

#### Operating Characteristics

Δ P minimum 0psid  
 Δ P maximum 150psi

#### Environmental Temp. Ranges:

##### Fluid Temperature Range:

\*0°F(-18°C) to185 F(85°C)

##### Ambient Temperature Range

14 F(-10°C) to122 F(50°C)

##### Compatible Fluids

Dry or lubricated air

##### Agency Approvals/Compliance

Din Coils: UL, CSA  
 Hazardous Coils: CSA, FM

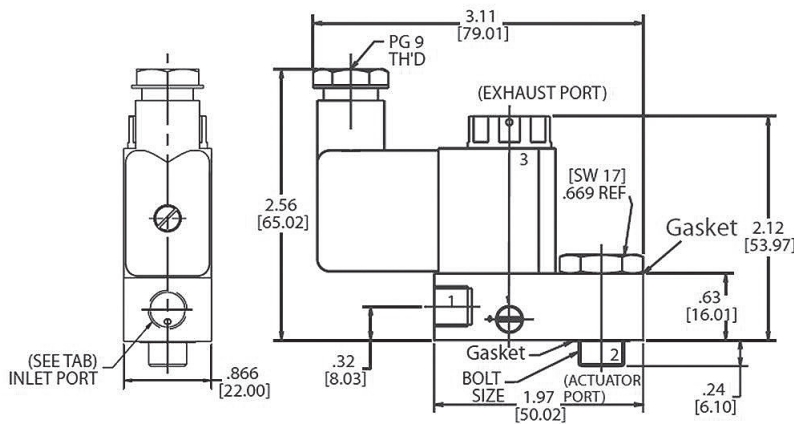

Dimensions shown are in inches and millimeters.

### Ordering Information

Part Number w/ DIN Coil & Connector	Actuator Enclosure Port 2	Valve Pressure Port 1
U131B01NDAx	G 1/8"	1/8" NPT
U131B02NDAx	G 1/4"	1/8" NPT
131B03NDAx	G 1/8"	G 1/8"
131B04NDAx	G 1/4"	G 1/8"

#### Voltage Code for Din Coil

A=12VDC B=24VDC E=24/60 F=120/60, 110/50 G=240/60, 220/50

Replace "x" in the Part number with one of the above Voltage Din Coil Codes.

# Sales Offices Worldwide

## Europe, Middle East, Africa

**AE - United Arab Emirates**, Dubai  
Tel: +971 4 8127100  
parker.me@parker.com

**AT - Austria**, Wiener Neustadt  
Tel: +43 (0)2622 23501-0  
parker.austria@parker.com

**AT - Eastern Europe**, Wiener Neustadt  
Tel: +43 (0)2622 23501 900  
parker.easteurope@parker.com

**AZ - Azerbaijan**, Baku  
Tel: +994 50 2233 458  
parker.azerbaijan@parker.com

**BE/LU - Belgium**, Nivelles  
Tel: +32 (0)67 280 900  
parker.belgium@parker.com

**BY - Belarus**, Minsk  
Tel: +375 17 209 9399  
parker.belarus@parker.com

**CH - Switzerland**, Etoy  
Tel: +41 (0) 21 821 87 00  
parker.switzerland@parker.com

**CZ - Czech Republic**, Klecany  
Tel: +420 284 083 111  
parker.czechrepublic@parker.com

**DE - Germany**, Kaarst  
Tel: +49 (0)2131 4016 0  
parker.germany@parker.com

**DK - Denmark**, Ballerup  
Tel: +45 43 56 04 00  
parker.denmark@parker.com

**ES - Spain**, Madrid  
Tel: +34 902 330 001  
parker.spain@parker.com

**FI - Finland**, Vantaa  
Tel: +358 (0)20 753 2500  
parker.finland@parker.com

**FR - France**, Contamine s/Arve  
Tel: +33 (0)4 50 25 80 25  
parker.france@parker.com

**GR - Greece**, Athens  
Tel: +30 210 933 6450  
parker.greece@parker.com

**HU - Hungary**, Budapest  
Tel: +36 1 220 4155  
parker.hungary@parker.com

**IE - Ireland**, Dublin  
Tel: +353 (0)1 466 6370  
parker.ireland@parker.com

**IT - Italy**, Corsico (MI)  
Tel: +39 02 45 19 21  
parker.italy@parker.com

**KZ - Kazakhstan**, Almaty  
Tel: +7 7272 505 800  
parker.easteurope@parker.com

**NL - The Netherlands**, Oldenzaal  
Tel: +31 (0)541 585 000  
parker.nl@parker.com

**NO - Norway**, Asker  
Tel: +47 66 75 34 00  
parker.norway@parker.com

**PL - Poland**, Warsaw  
Tel: +48 (0)22 573 24 00  
parker.poland@parker.com

**PT - Portugal**, Leca da Palmeira  
Tel: +351 22 999 7360  
parker.portugal@parker.com

**RO - Romania**, Bucharest  
Tel: +40 21 252 1382  
parker.romania@parker.com

**RU - Russia**, Moscow  
Tel: +7 495 645-2156  
parker.russia@parker.com

**SE - Sweden**, Spånga  
Tel: +46 (0)8 59 79 50 00  
parker.sweden@parker.com

**SK - Slovakia**, Banská Bystrica  
Tel: +421 484 162 252  
parker.slovakia@parker.com

**SL - Slovenia**, Novo Mesto  
Tel: +386 7 337 6650  
parker.slovenia@parker.com

**TR - Turkey**, Istanbul  
Tel: +90 216 4997081  
parker.turkey@parker.com

**UA - Ukraine**, Kiev  
Tel: +380 44 494 2731  
parker.ukraine@parker.com

**UK - United Kingdom**, Warwick  
Tel: +44 (0)1926 317 878  
parker.uk@parker.com

**ZA - South Africa**, Kempton Park  
Tel: +27 (0)11 961 0700  
parker.southafrica@parker.com

## North America

**CA - Canada**, Milton, Ontario  
Tel: +1 905 693 3000

**US - USA**, New Britain, CT  
Tel: +1 860 827 2300

## Asia Pacific

**AU - Australia**, Castle Hill  
Tel: +61 (0)2-9634 7777

**CN - China**, Shanghai  
Tel: +86 21 2899 5000

**HK - Hong Kong**  
Tel: +852 2428 8008

**IN - India**, Mumbai  
Tel: +91 22 6513 7081-85

**JP - Japan**, Tokyo  
Tel: +81 (0)3 6408 3901

**KR - South Korea**, Hwaseong  
Tel: +82 31 379 2234

**MY - Malaysia**, Shah Alam  
Tel: +60 3 7849 0800

**NZ - New Zealand**, Mt Wellington  
Tel: +64 9 574 1744

**SG - Singapore**  
Tel: +65 6887 6300

**TH - Thailand**, Bangkok  
Tel: +662 186 7000 99

**TW - Taiwan**, Taipei  
Tel: +886 2 2298 8987

## South America

**AR - Argentina**, Buenos Aires  
Tel: +54 3327 44 4129

**BR - Brazil**, Sao Jose dos Campos  
Tel: +55 800 727 5374

**CL - Chile**, Santiago  
Tel: +56 2 623 1216

**MX - Mexico**, Apodaca  
Tel: +52 81 8156 6000

**VE - Venezuela**, Caracas  
Tel: +58 212 238 5422

