



ALFRA ROTASPEED®



ERGONOMICALLY
DESIGNED HAND GRIP



LASER
POINT

MOTOR WITH
HIGH-PERFORMANCE GEARBOX

CONTINUOUSLY ADJUSTABLE
MITRE UP TO 45°
(WITH 5 LOCKING OPTIONS)

SOLID BASE PLATE

AUTOMATIC
SAW BLADE PROTECTION

SAFETY SWITCH



TOOL-LESS
CUTTING HEIGHT ADJUSTMENT

SPINDLE LOCK FOR
EASY SAW BLADE REPLACEMENT



B



ALFRA-ROTA SPEED® – METAL CIRCULAR SAW RS 230A



Hand-operated

The ideal machine for construction sites and workshops, for low-burr cutting without cooling.

For rapid, clean cuts in tubes, threaded rods, profiles, cable ducts, corrugated and trapezoid sheeting, sandwich sheets, drywall profiles and much more.

The advantages at a glance:

- 1.800 Watt high-performance motor for exact cutting without cooling.
- Quick, easy saw-blade change.
- Continuously adjustable cutting depth up to 82 mm.
- The saw shoe can be adjusted for mitre cuts of up to 45°.
- Chip collection container.
- The ideal machine for side assembly companies, facade builders, repair shops, locksmitheries, rack builders, roofers, booth builders, welding shops, and heating and ventilation contractors.
- Ideal applicable where angle grinders are not strong enough, or clean enough.
- Mitre cutting also makes it deal for weld preparation.
- With optical laser for proper alignment of cuts.



Prod.-No. 22411

ALFRA RotaSpeed® RS 230A

Saw blade diameter:	230 (9")
Saw blade arbor:	25.4 mm (1")
Rating:	1.800 Watt
RPM min ⁻¹ :	2.700
Mitre:	0 - 45°
Cutting capacity, mm 0°:	82
Cutting capacity, mm 45°:	56
Max. material thickness (dependent on material):	8 mm
Volt:	230 - 50 Hz
Weight:	9.8 kg

Prod.-No.
22411

Alfra RotaSpeed® RS 230A

Scope of Supply:

Machine with 2 TCT Saw blades (premium quality), operating manual, rip fence, tool set, spacer piece for saw blade arbor, carrying case.



B



ALFRA-CIRCULAR SAW BLADES – ROTASPEED®

Carbide-tipped • Made in Germany

- Tungsten carbide tipped, suitable for metal cutting saws from: ALFRA, Flex, Euroboor, Evolution, Hitech, Jepson, Metallkraft, Ridgid, etc.
- These special TCT circular saws ensure fast and clean cuts in pipes, threaded rods, profiles, corrugated and trapezoidal sheets, wire ducts, sandwich panels, dry mortarless construction profiles, fastening profiles (DIN rails), grates using dry cutting method.
- For use on metals, CrNi steel*, aluminium.
- High cutting performance and tool life. The excellent price/performance ratio makes these saws highly economical.
- The corresponding manufacturer's machine guidelines and notes on use must be observed when using these saw blades.

Premium quality

Cutting- Ø mm	Application	Dimensions mm	No. of teeth	Prod.-No.
180/7"	Steel	180 x 20	34	22205
200/8"	Steel	200 x 20	42	22255
230/9"	Steel	230 x 25.4	48	22305
230/9"	Aluminium	230 x 25.4	62	22306
230/9"	For trapezoid sheeting	230 x 25.4	80	22307

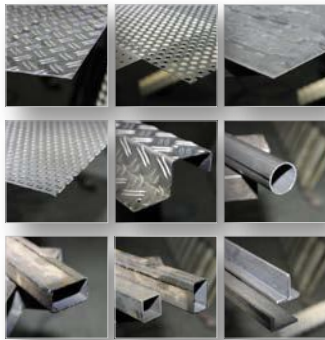

MAGNETIC CHIP REMOVER

In a stainless steel round rod, you can move a magnet back and forth. The strong magnet picks up metal chips - pull a knob and the chips fall off. For more cleanliness in the work place.

Prod.-No.
18654

ALFRA magnetic chip remover, length 400 mm



Prod.-No. 18654





ALFRA-ROTA DRY® – METAL DRY CUTTER 355



Overwhelming quality, performance and price:

- for low-burr cutting of profiles and tubes, in steel, iron, copper, brass, aluminium, plastics, composites and stainless steel with no cooling.
- for use in applications such as metal-working, in joineries, for interior construction, etc.
- with depth adjustment for precise cutting
- angle and rip fence for mitre cuts of up to 45°
- with removable chip collection box
- with arbor adjustment for changing the saw blade
- easy to transport

ALFRA RotaDry® 355

Motor	230 V/50 Hz	
Power consumption	2.200 W	
RPM	1.300 min ⁻¹	
Cutting area 90°	13 mm wall thickness	180 x 105 mm ☐
Cutting area 90°	13 mm wall thickness	120 x 120 mm ☐
Cutting area 90°	13 mm wall thickness	135 mm ∅
Cutting area 45°	13 mm wall thickness	110 x 100 mm ☐
Cutting area 45°	13 mm wall thickness	100 x 100 mm ☐
Cutting area 45°	13 mm wall thickness	105 mm ∅
Saw blade diameter	355 mm	
Weight	23 kg	



Prod.-No. 22420

Alfra RotaDry® 355, with 1 TCT Saw blade 72 T	Prod.-No. 22420
---	---------------------------

Accessories:

Robust prismatic jaws The ideal assistant, especially when cutting tubes with thin walls	22421
Work table RCT 6542	22601



Prod.-No. 22601

Spare TCT saw blades

Also suitable for cutters such as:

Jepson/Global/Ridgid/Ryobi

The universal TCT Saw blade for rapid cutting in:

Steel – Copper – Aluminium – Profiles – Cables – Sheeting – Solid materials

- without coolant
- regrindable
- low noise thanks to laser ornaments

Dimensions		Steel	Stainless steel	Prod.-No.
305 x 2.2 x 25.4 mm	60 T	•		32100
305 x 2.2 x 25.4 mm	80 T	•		32101
355 x 2.4/2.0 x 25.4 mm	72 T	•		32108
355 x 2.6 x 25.4 mm	80 T	•		32103
355 x 2.6 x 25.4 mm	90 T	•		32102
355 x 2.6 x 25.4	90 T	coated	•	32105

Other tooth counts upon request.

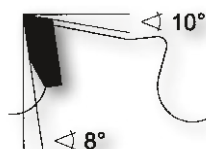
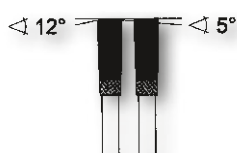

355 x 2.6 x 25.4 • 90 Z • coated

B



ALFRA ROTACUT®

BAND SAW BLADE TENSIONING
WITH OVERLOAD PROTECTION

ERGONOMICALLY-SHAPED
HANDLE

CLAMPING VICE

TORSION-FREE,
PRECISION-MILLED SAW FRAME

HIGH-PERFORMANCE
SINGLE-PHASE-MOTOR

CONTINUOUSLY ADJUSTABLE
MITRE CUT 0 - 45° (60°)

ROBUST BASE WITH FEET



Portable Band Saw Machines for Professionals

There is a variety of portable band saw machines, but only a few of them are suitable for industrial applications or at a construction site. Pricing is usually being more important than reliability and durability.

Our new machines have an excellent price-performance-ratio and are setting new standards. The robust and compact design makes it ideal for handling in the machine shop or the construction site.

Ideally qualified for locksmiths, plumbing, metal-, heating-, pipeline- and mechanical workshops. Also for construction companies, public utilities with or without mobile workshops, power stations, schools, technical learning and teaching facilities.

Special features:

- Fully portable
- For mitre cuts 0 - 45° (60°) continuously adjustable
- Extremely rapid saw belt replacement
- Secure material tensioning
- Robust high-performance motor, RPM continuously adjustable (also ideal for stainless steel)
- Adjustable ball-bearing belt-guide for exact, precise angle-cutting
- Patented belt-tensioning with overload protection



Practical carrying handle



Mitring, continuously adjustable to 45° (60°)

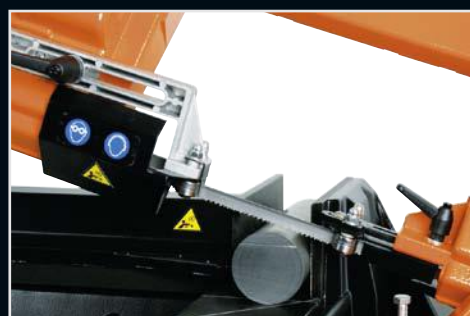

Fine-tuned, adjustable belt guide



Patented belt-tensioning



ALFRA BAND SAW - RC 105



Prod.-No. 22600

Band saw RC 105

Prod.-No.
22600

Band saw RC 105

Technical specifications:

Single-phase motor	950 W
Voltage	230 Volt
Cutting speed	30 to 80 min ⁻¹
(continuously adjustable with thermal and overload protection)	
Mitring	0 - 45°
Belt dimensions	1.335 x 13 x 0.65 mm
Weight	16 kg

Scope of Supply:

- Portable Band Saw Machine RC 105 - 230 V
- Complete with HSS bi-metal saw band
- Operating manual

CUTTING CAPACITY

	∅	∇	∇
0°	105 mm	95 x 95 mm	100 x 85 mm
45°	65 mm	65 x 65 mm	65 x 60 mm

BAND SAW BLADES HSS BI-METAL FOR RC 105

Prod.-No.	Dimensions
341-13065-1335-0600	1335x13x0.65 mm 6 Z
341-13065-1335-0812	1335x13x0.65 mm 8/12 Z
341-13065-1335-1400	1335x13x0.65 mm 14 Z



ALFRA BAND SAW - RCP 120



Prod.-No. 22620

Band saw RCP 120

Band saw RCP 120

Prod.-No.
22620

Technical specifications:

Single-phase motor	1.300 W
Voltage	230 Volt
Cutting speed	35 to 80 min ⁻¹
(continuously adjustable with thermal and overload protection)	
Mitring	0 - 60°
Belt dimensions	1.440 x 13 x 0.65 mm
Weight	18 kg

Scope of Supply:

- Portable Band Saw Machine RCP 120 - 230 V
- Complete with HSS bi-metal saw band
- Operating manual

CUTTING CAPACITY

	∅	∇	∇
0°	120 mm	112 x 112 mm	120 x 102 mm
45°	80 mm	78 x 78 mm	78 x 78 mm
60°	50 mm	43 x 43 mm	50 x 43 mm

BAND SAW BLADES HSS BI-METAL FOR RCP 120

Prod.-No.	Dimensions
341-13065-1440-0600R	1440x13x0.65 mm 6 Z
341-13065-1440-0812R	1440x13x0.65 mm 8/12 Z
341-13065-1440-1400R	1440x13x0.65 mm 14 Z

B



ALFRA BAND SAW - RCP 150



Prod.-No. 22630

Band saw RCP 150

Band saw RCP 150

Prod.-No.

22630

Technical specifications:

Single-phase motor	2.000 W
Voltage	230 Volt
Cutting speed	35 to 80 min ⁻¹
(continuously adjustable with thermal and overload protection)	
Mitring	0 - 45°
Belt dimensions	1.735 x 13 x 0.9 mm
Weight	35 kg

Scope of Supply:

- Portable Band Saw Machine RCP 150 - 230 V
- complete with HSS bi-metal saw band
- Operating manual

CUTTING CAPACITY

	∅	∇	∇
0°	150 mm	150 x 150 mm	160 x 140 mm
45°	100 mm	100 x 100 mm	120 x 100 mm

BAND SAW BLADES HSS BI-METAL FOR RCP 150

Prod.-No.	Dimensions
341-13090-1735-0600R	1735x13x0.9 mm 6 Z
341-13090-1735-0610R	1735x13x0.9 mm 6/10 Z
341-13090-1735-1400R	1735x13x0.9 mm 14 Z



ALFRA BAND SAW - RC 210



Prod.-No. 22660



Band saw

Band saw RC 210

Prod.-No.
22660

Technical specifications:

Single-phase motor	1.850 W
Voltage	230 Volt
Cutting speed	60 / 80 min ⁻¹
(constant due to electr. control)	
Mitring	0 - 45°
Belt dimensions	2.140 x 20 x 0.9 mm
Weight	59 kg

Mobile Band Saw Machine, ideal for use on the move in a construction site.

Scope of Supply:

- Portable Band Saw Machine RC 210 - 230 V
- complete with HSS bi-metal saw band
- Operating manual

CUTTING CAPACITY

	∅	∇	∇
0°	175 mm	150 x 150 mm	213 x 150 mm
45°	140 mm	140 x 140 mm	145 x 80 mm



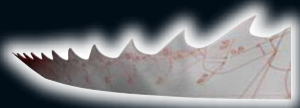

BAND SAW BLADES HSS BI-METAL FOR RC 210

Prod.-No.	Dimensions
341-20090-2140-0406	2140x20x0.9 mm 4/6 Z
341-20090-2140-0610	2140x20x0.9 mm 6/10 Z
341-20090-2140-1400	2140x20x0.9 mm 14 Z

B



ALFRA BAND SAW BLADES HSS-BI-METAL

Suitable for	Dimensions	Prod.-No.
 ROTACUT RC 105	1335x13x0.65 mm 6 Z	341-13065-1335-0600
	1335x13x0.65 mm 8/12 Z	341-13065-1335-0812
	1335x13x0.65 mm 14 Z	341-13065-1335-1400
 ROTACUT RCP 120	1440x13x0.65 mm 6 Z	341-13065-1440-0600R
	1440x13x0.65 mm 8/12 Z	341-13065-1440-0812R
	1440x13x0.65 mm 14 Z	341-13065-1440-1400R
 ROTACUT RCP 150	1735x13x0.9 mm 6 Z	341-13090-1735-0600R
	1735x13x0.9 mm 6/10 Z	341-13090-1735-0610R
	1735x13x0.9 mm 14 Z	341-13090-1735-1400R
 ROTACUT RC 210	2140x20x0.9 mm 4/6 Z	341-20090-2140-0406
	2140x20x0.9 mm 6/10 Z	341-20090-2140-0610
	2140x20x0.9 mm 14 Z	341-20090-2140-1400

B



ALFRA WORKBENCH – RCT 6542



Prod.-No. 22601

Work table RCT 6542

Work bench RCT 6542

Prod.-No.

22601

The advantages at a glance:

- cost-effective, sturdy, fully collapsible work bench
- ideal for the construction site
- made of steel profiles
- height-adjustable in three steps: 740 - 820 - 870 mm
- for a wide variety of applications
- table size 650 x 420 mm
- for all portable Rotacut® and RotaDry® band saws
- fully collapsible, portable
- weight 11 kg

Scope of Supply:

- Portable work bench RCT 6542
- Operating manual

B



ALFRA HSS BI-METAL

HOLE SAWS

Features:

- M42
- High concentricity
- With solid base plate, thus more threads and higher stability as well as concentric running exactness.
- For material from 2 mm – with positive chipping and cutting angles as well as combi-toothing 4/6 tpi. This variable spacing provides a more even cut, for a minor generation of vibrations and heat. Lower expenditure of energy when cutting.
- Cutting Depth: 38 mm (1-1/2").
- Lateral slots help to remove the core.
- Suitable for unalloyed steel (up to 700 N/mm²), nonferrous metals, light metals, plastics, gypsum, pulp wood- and plywood boards, lightweight building boards and general wood processing.
- Drill bit exchangeable with other commercially available arbors.





B



Also steel/stainless steel up to approx. 3 mm, can be worked easily (for frequent use, we recommend our TCT Hole Saws).



... designed to work on softwoods.



ALFRA – HSS-BI-METAL HOLE SAWS

ALFRA HSS-Bi-Metal Hole Saws are applicable in portable and pillar drilling machines. When using pillar drilling machines, use manual feed only.

Features:

- M42
- High concentricity.
- With solid base plate, thus more threads and higher stability as well as concentric running exactness.
- With positive chipping and cutting angles as well as combi-toothing 4/6 tpi. This variable spacing provides a more even cut, for a minor generation of vibrations and heat. Lower expenditure of energy when cutting.
- Cutting Depth: 38 mm (1-1/2").
- Lateral slots help to remove the core.
- Suitable for unalloyed steel (up to 700 N/mm²), nonferrous metals, light metals, plastics, gypsum, pulp wood- and plywood boards, lightweight building boards and general wood processing.
- Drill bit exchangeable with other commercially available arbors.

Tip:

Start drilling operation with light pressure. Continue with light and steady pressure, avoid pendulum motion, follow the speed chart, use coolant. When cutting wood or wood substitutes, remove drill dust in time.



Combi toothing 4/6 tpi



from Ø 14.0 to 210 mm available

Saw Ø mm	Inches	Prod.-No.
14.0	9/16"	0500014
16.0	5/8"	0500016
17.0	11/16"	0500017
19.0	3/4"	0500019
20.0	15/16"	0500020
21.0	13/16"	0500021
22.0	7/8"	0500022
24.0	15/16"	0500024
25.0	1"	0500025
27.0	11/16"	0500027
29.0	1-1/8"	0500029
30.0	1-3/16"	0500030
32.0	1-1/4"	0500032
33.0	1-5/16"	0500033
35.0	1-3/8"	0500035
37.0	1-7/16"	0500037
38.0	1-1/2"	0500038
40.0	1-9/16"	0500040
41.0	1-5/8"	0500041
43.0	1-11/16"	0500043
44.0	1-3/4"	0500044
46.0	1-13/16"	0500046
48.0	1-7/8"	0500048
51.0	2"	0500051
52.0	2-1/16"	0500052
54.0	2-1/8"	0500054
57.0	2-1/4"	0500057
59.0	2-5/16"	0500059
60.0	2-3/8"	0500060
64.0	2-1/2"	0500064
65.0	2-9/16"	0500065
67.0	2-5/8"	0500067
68.0	2-11/16"	0500068
70.0	2-3/4"	0500070
73.0	2-7/8"	0500073





ALFRA - HSS BI-METAL HOLE SAWS



Saw Ø mm	Inches	Prod.-No.
74.0	2-11/12"	0500074
76.0	3"	0500076
79.0	3-1/8"	0500079
83.0	3-1/4"	0500083
86.0	3-3/8"	0500086
89.0	3-1/2"	0500089
92.0	3-5/8"	0500092
95.0	3-3/4"	0500095
98.0	3-7/8"	0500098
102.0	4"	0500102
105.0	4-1/8"	0500105
108.0	4-1/4"	0500108
111.0	4-3/8"	0500111
114.0	4-1/2"	0500114
121.0	4-3/4"	0500121
127.0	5"	0500127
140.0	5-1/2"	0500140
152.0	6"	0500152
From Ø 160.0 mm only suitable for wood and wood substitutes.		
160.0	6-5/16"	0500160
168.0	6-10/16"	0500168
177.0	7"	0500177
210.0	8-5/16"	0500210

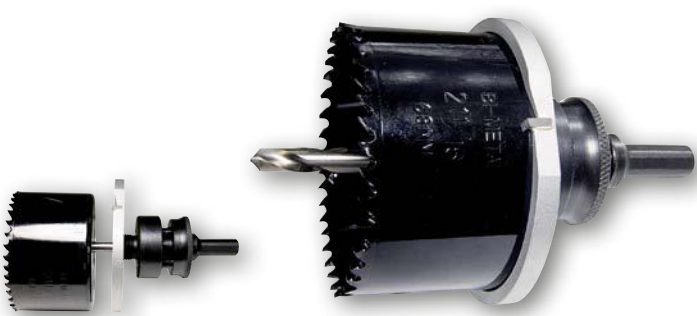

Prod.-No. 0501013 with bi-metal hole saw Ø 68 mm + A2-SS

Arbors

with pilot drill

Saw-Ø mm	Saw-Ø inch	Type	Shank-Ø	Prod.-No.
14 - 30	9/16 - 1 3/16	A 6-SS	9.5 hexagon	0501001
14 - 30	9/16 - 1 3/16	A 6-SDS	SDS	0501002
32 - 152	1 1/4 - 6	A 2-SS	9.5 hexagon	0501003
32 - 152	1 1/4 - 6	A 2-SDS	SDS	0501005
32 - 210	1 1/4 - 8 5/16	A 3-SS	11.11 hexagon	0501006
32 - 210	1 1/4 - 8 5/16	A 5-SS	16.0 hexagon	0501008

Accessories:

Rim countersink for Ø 68 mm (with TCT-teeth)	0501013
Extension shaft 300 mm x 9.5 mm for A 6-SS + A 2-SS, A3-SS	0501010
Spare Center Drill HSS Ø 6.35 mm x 80 mm for A 6-SS + A 6-SDS + A 2-SS + A 2-SDS + A 3-SS + A 5-SS	0502001
Ejector Spring	0502004

Important: Disable impact drill position when using SDS-shanks!

9.5 mm
3/8"

Prod.-No. 0501001 A6-SS

SDS plus

Prod.-No. 0501002 A6-SDS

9.5 mm
3/8"

Prod.-No. 0501003 A2-SS

SDS plus

Prod.-No. 0501005 A2-SDS

11.11 mm
7/16"

Prod.-No. 0501006 A3-SS



Prod.-No. 0501013



Prod.-No. 0501010



Prod.-No. 0502001

Prod.-No. 0502004

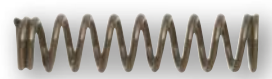

B



ALFRA - HSS BI-METAL HOLE SAW SETS

The following HSS-Bi-Metal Hole Saw Sets enlarge our range. These sets were especially compiled for electricians, mechanics, plumbers and for general, universal applications. These sets improve the presentation. Storage in solid tool cases.

Hole Saw Set Standard

Prod.-No.

0503006

Contents:

- Ø 16 mm ($\frac{5}{8}$ "
- Ø 19 mm ($\frac{3}{4}$ "
- Ø 22 mm ($\frac{7}{8}$ "
- Ø 29 mm ($1 \frac{1}{8}$ "
- Ø 35 mm ($1 \frac{3}{8}$ "
- Ø 44 mm ($1 \frac{3}{4}$ "
- Ø 52 mm ($2 \frac{1}{16}$ "
- Ø 57 mm ($2 \frac{1}{4}$ "
- Ø 67 mm ($2 \frac{5}{8}$ "

Arbor A6-SS, Arbor A2-SS, Spare Twist Drill



Prod.-No. 0503006

Hole Saw Set Professional

Prod.-No.

0503007

Contents:

- Ø 16 mm ($\frac{5}{8}$ "
- Ø 19 mm ($\frac{3}{4}$ "
- Ø 22 mm ($\frac{7}{8}$ "
- Ø 25 mm (1")
- Ø 29 mm ($1 \frac{1}{8}$ "
- Ø 32 mm ($1 \frac{1}{4}$ "
- Ø 35 mm ($1 \frac{3}{8}$ "
- Ø 38 mm ($1 \frac{1}{2}$ "
- Ø 44 mm ($1 \frac{3}{4}$ "
- Ø 51 mm (2")
- Ø 64 mm ($2 \frac{1}{2}$ "
- Ø 76 mm (3")

Arbor A6-SS, Arbor A2-SS, Spare Twist Drill



Prod.-No. 0503007

Hole Saw Set Electro

Prod.-No.

0503008

Contents:

- Ø 22 mm ($\frac{7}{8}$ "
- Ø 29 mm ($1 \frac{1}{8}$ "
- Ø 35 mm ($1 \frac{3}{8}$ "
- Ø 44 mm ($1 \frac{3}{4}$ "
- Ø 51 mm (2")
- Ø 64 mm ($2 \frac{1}{2}$ "
- Ø 68 mm ($2 \frac{11}{16}$ "

Arbor A6-SS, Arbor A2-SS, Spare Twist Drill



Prod.-No. 0503008

Hole Saw Set Sanitary

Prod.-No.

0503009

Contents:

- Ø 16 mm ($\frac{5}{8}$ "
- Ø 19 mm ($\frac{3}{4}$ "
- Ø 24 mm ($\frac{15}{16}$ "
- Ø 29 mm ($1 \frac{1}{8}$ "
- Ø 38 mm ($1 \frac{1}{2}$ "
- Ø 44 mm ($1 \frac{3}{4}$ "
- Ø 57 mm ($2 \frac{1}{4}$ "
- Ø 67 mm ($2 \frac{5}{8}$ "

Arbor A6-SS, Arbor A2-SS, Spare Twist Drill



Prod.-No. 0503009

ALFRA HOLE SAWS

The quality is in the detail

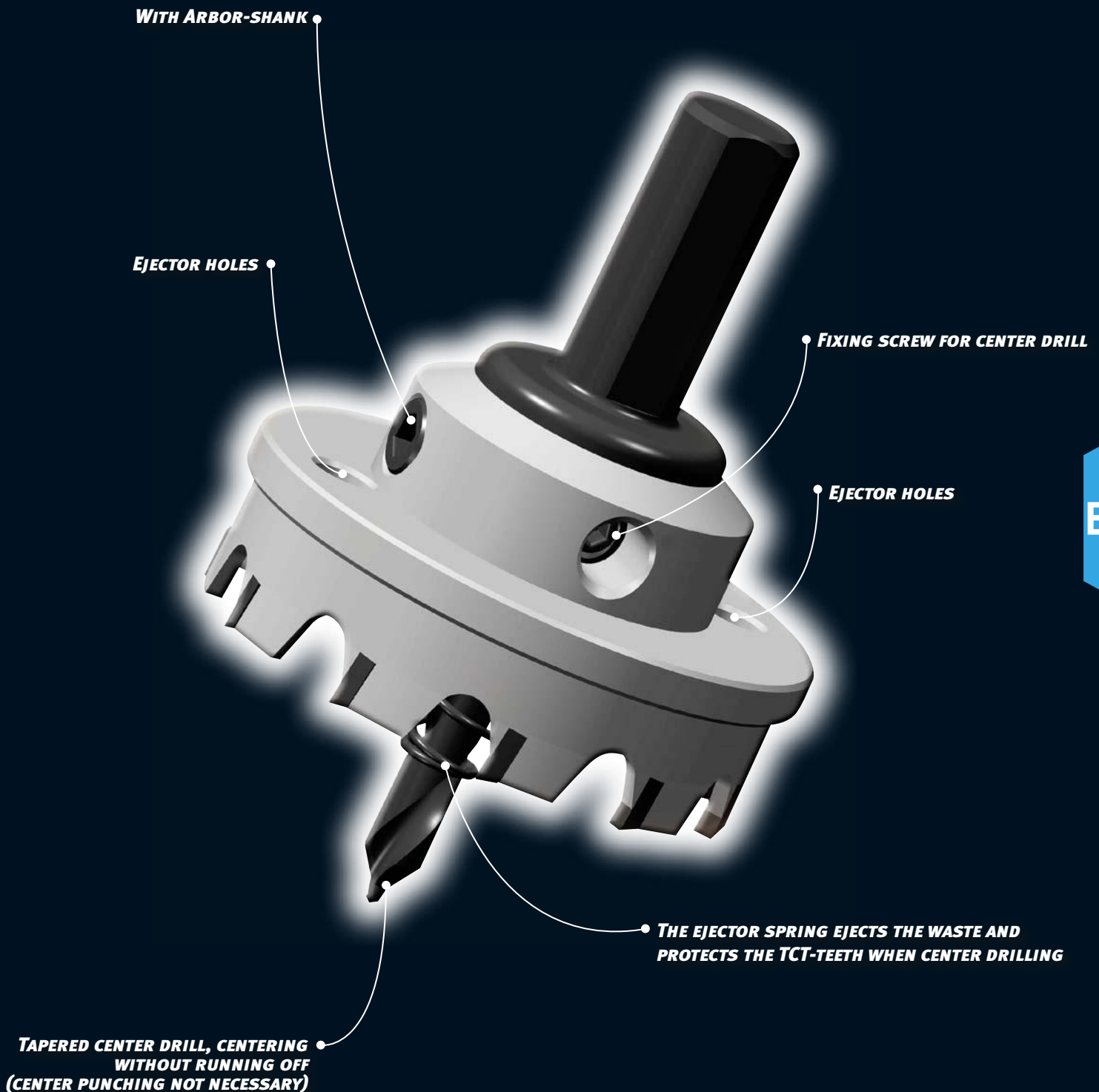

B



TCT-HOLE SAWS IN USE



TCT-Hole Saws – short-/long type



Stainless steel



Plastic



Poroton brick stone



TCT-Hole Saws – FRP type



TCT-Hole Saws – MBS type



Sanitary pipes – type SML



*MBS Pro
Use on Rotabest Magnetic Drilling Machine
with MT3 – Arbor Prod.-No.: 0734003*



Checker plate (stainless steel)



Sanitary pipes – type SML



ALFRA TGT-HOLE SAWS – SHORT TYPE

Made in Germany by ALFRA

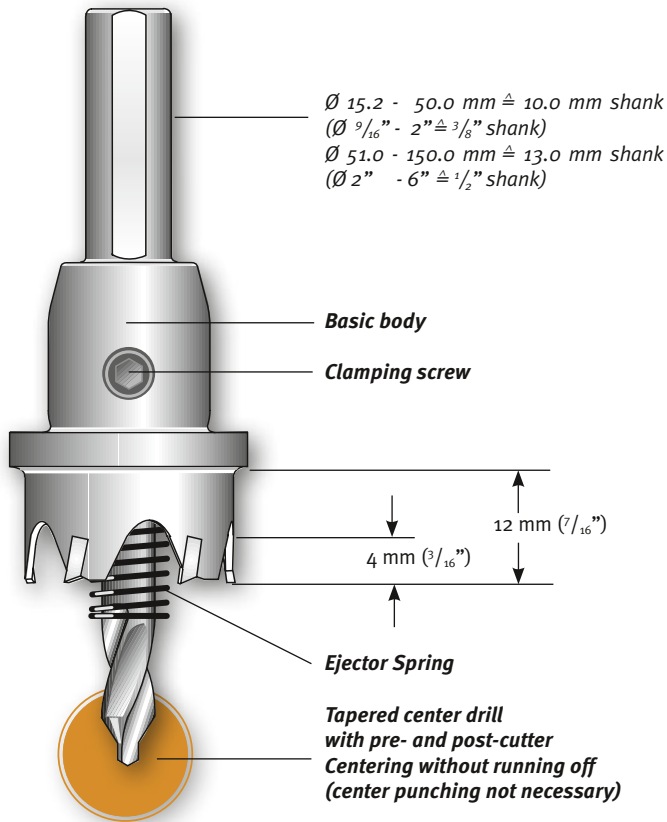

The application area of TCT Hole Saws differs from HSS-Bi-Metal Hole Saws. With ALFRA TCT Hole Saws, suitable to economically process stainless steel up to 2 mm (1/16"), unalloyed steels up to 4 mm (3/16"), plastics, PVC, aluminium, zinc, gypsum plaster boards and lightweight building boards, as well as asbestos. Do not use automatic feed, when working with pillar drilling machines. For the use on portable- and pillar drilling machines. Do not use automatic feed, when working with pillar drilling machines.

Features:

- High concentric running exactness through solid construction.
- CAD-optimized cutting angles with specially ground section ensures high cutting capacity and long tool life.
- Quick removal of drilled core through ejector spring for all hole saws up to 150 mm (5-29/32") \varnothing .
- Carbide tipping enables repeated re-grinding.
- ALFRA hole saws are repairable. In the event of a tooth breaking, it can easily be replaced and resharpened.
- Exchangeable center pin.
- Use of MT tool holders from $\varnothing 31 \text{ mm}$ (1-7/32").
- For use on hand drilling machines (recommended up to max. $\varnothing 40 \text{ mm}$; 1-9/16") or stationary machines.

Tips:

- At thicker materials: cut 2-3 mm per cutting process, remove chips afterwards.
- When cutting metals, a high- grade cutting oil should be used. Exception: Do not use cutting oil when using cast iron, use paraffin instead of oil when cutting aluminium.
- **Keep in mind: Always wear safety goggles.**



Another special technical feature:

From $\varnothing 15.2 \text{ mm}$ (3/16") to 30.0 mm (1 1/8"), the hole saw is made of one piece.

From $\varnothing 31.0 \text{ mm}$ (1-3/16") we use specially hardened tool holders to compensate for the torsional power in case of heavy operation, which avoids early shearing off of the tool holder shank.

In terms of construction not comparable with any other make.



ALFRA TGT-HOLE SAWS - SHORT TYPE

Made in Germany by ALFRA



Ø mm	Ø Inches	No. of teeth	Prod.-No. mm
Ø 15.2	15	4	0600152
Ø 16.0	5/8"	4	0600160
Ø 17.0		4	0600170
Ø 18.0	11/16"	4	0600180
Ø 18.6		4	0600186
Ø 19.0	3/4"	4	0600190
Ø 20.0		5	0600200
Ø 20.4		5	0600204
Ø 21.0	13/16"	5	0600210
Ø 22.0		5	0600220
Ø 22.5		5	0600225
Ø 23.0	7/8"	5	0600230
Ø 24.0	15/16"	5	0600240
Ø 25.0		5	0600250
Ø 26.0	1"	5	0600260
Ø 27.0	1-1/16"	5	0600270
Ø 28.0		5	0600280
Ø 28.3		5	0600283
Ø 29.0	1-1/8"	5	0600290
Ø 30.0	1-3/16"	5	0600300
Ø 31.0		6	0600310
Ø 32.0	1-1/4"	6	0600320
Ø 33.0		6	0600330
Ø 34.0	1-5/16"	6	0600340
Ø 35.0	1-3/8"	6	0600350
Ø 36.0		6	0600360
Ø 37.0	1-7/16"	7	0600370
Ø 38.0		7	0600380
Ø 39.0	1-1/2"	7	0600390
Ø 40.0	1-9/16"	7	0600400
Ø 41.0		8	0600410
Ø 42.0	1-5/8"	8	0600420
Ø 43.0	1-11/16"	8	0600430
Ø 44.0		8	0600440
Ø 45.0	1-3/4"	8	0600450
Ø 46.0		8	0600460
Ø 47.0	1-13/16"	9	0600470
Ø 48.0	1-7/8"	9	0600480
Ø 49.0		9	0600490
Ø 50.0	1-15/16"	9	0600500
Ø 51.0	2"	9	0600510
Ø 52.0		10	0600520
Ø 53.0	2-1/16"	10	0600530
Ø 54.0	2-1/8"	10	0600540
Ø 55.0		10	0600550
Ø 56.0	2-3/16"	10	0600560
Ø 57.0	2-1/4"	10	0600570
Ø 58.0		10	0600580
Ø 59.0	2-5/16"	10	0600590
Ø 60.0	2-3/8"	10	0600600
Ø 61.0		11	0600610
Ø 62.0	2-7/16"	11	0600620
Ø 63.0		11	0600630
Ø 64.0	2-1/2"	11	0600640
Ø 65.0		11	0600650
Ø 66.0	2-9/16"	12	0600660
Ø 67.0	2-5/8"	12	0600670
Ø 68.0		12	0600680
Ø 69.0	2-11/16"	12	0600690
Ø 70.0	2-3/4"	12	0600700
Ø 71.0		12	0600710
Ø 72.0	2-13/16"	13	0600720
Ø 73.0	2-7/8"	13	0600730
Ø 74.0	2-15/16"	13	0600740
Ø 75.0		13	0600750
Ø 76.0	3"	13	0600760

Ø mm	Ø Inches	No. of teeth	Prod.-No. mm
Ø 77.0		13	0600770
Ø 78.0	3-1/16"	14	0600780
Ø 79.0	3-1/8"	14	0600790
Ø 80.0		14	0600800
Ø 81.0	3-3/16"	14	0600810
Ø 82.0		14	0600820
Ø 83.0	3-1/4"	14	0600830
Ø 84.0	3-5/16"	15	0600840
Ø 85.0		15	0600850
Ø 86.0	3-3/8"	15	0600860
Ø 87.0	3-7/16"	15	0600870
Ø 88.0		15	0600880
Ø 89.0	3-1/2"	16	0600890
Ø 90.0	3-9/16"	16	0600900
Ø 91.0		16	0600910
Ø 92.0	3-5/8"	16	0600920
Ø 93.0		16	0600930
Ø 94.0	3-11/16"	16	0600940
Ø 95.0	3-3/4"	17	0600950
Ø 96.0		17	0600960
Ø 97.0	3-13/16"	17	0600970
Ø 98.0	3-7/8"	17	0600980
Ø 99.0		17	0600990
Ø 100.0	3-15/16"	17	0601000
Ø 105.0	4"	18	0601050
Ø 110.0		18	0601100
Ø 115.0	4-1/2"	20	0601150
Ø 120.0		20	0601200
Ø 125.0		20	0601250
Ø 130.0	5"	20	0601300
Ø 135.0		24	0601350
Ø 140.0	5-1/2"	24	0601400
Ø 145.0		24	0601450
Ø 150.0		24	0601500

HSS-Spare Drill

with tapered center tip		
from Ø 15.2 - 100.0	Ø 6x50 mm	0602650
from Ø 101.0 - 150.0	Ø 8x50 mm	0602850

MT Arbors

MT-2 (Ø 31.0 - 100.0 mm)	0734002
MT-3 (Ø 31.0 - 150.0 mm)	0734003

SDS Arbor

SDS arbor shank (for use with Ø 31.0 - 100.0 mm)	060sds6
---	---------

Spare Ejector

from Ø 15.2 - 150.0	Ø 6 mm	0602006
---------------------	--------	---------

Coolant ALFRA

ALFRA BIO 2000 For mild steel DIN S233, 405 ml	21010
ALFRA 3000 For chromium nickel steel 520 ml	21030
ALFRA 4000 For titanium and manganese-carbon steels 300 ml	21040



Prod.-No. 0600001

Set Metric

Set Metric	Prod.-No. 0600001
------------	----------------------

Contents:
1 each of Ø 16/20/25/32/40 mm
2 Allen Keys



Prod.-No. 21010

Prod.-No. 21030

Prod.-No. 21040

B



ALFRA TGT-HOLE SAWS – LONG TYPE

Made in Germany by ALFRA

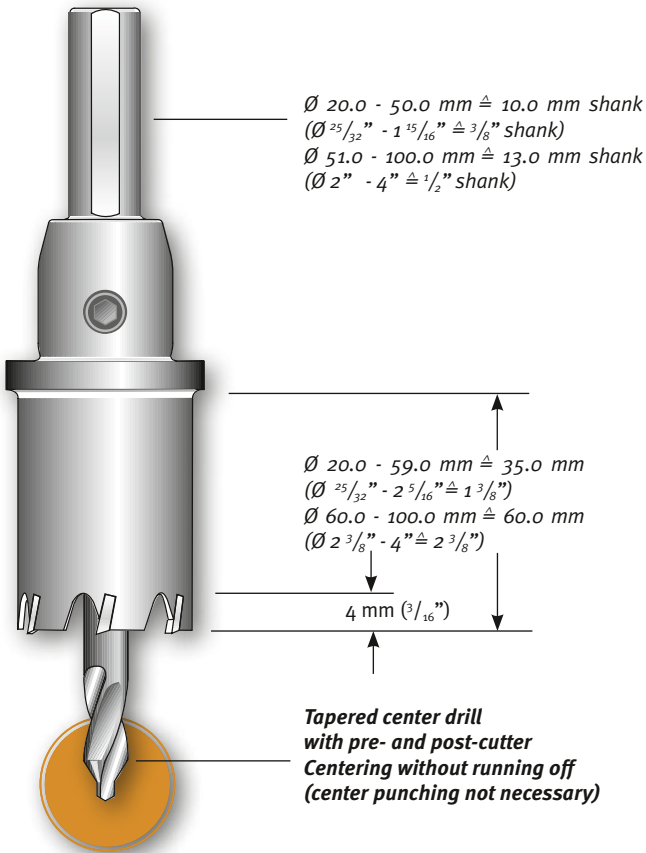

Features:

- Especially developed for the use on pipes, vaulted materials, for unalloyed and alloyed steels, nonferrous metals, plastics as well as glass fibre reinforced plastic.
- For material thickness up to 4 mm ($\frac{3}{16}''$), 2 mm ($\frac{1}{16}''$) stainless steel.
- For use on hand drilling machines, recommended up to max. $\varnothing 40 \text{ mm}$ ($1\text{-}9/16''$) or stationary machines.

Tips:

- Start drilling operation with light pressure, when drilling pipes. Avoid pendulum motions.
- Keep in mind: Always wear safety goggles.

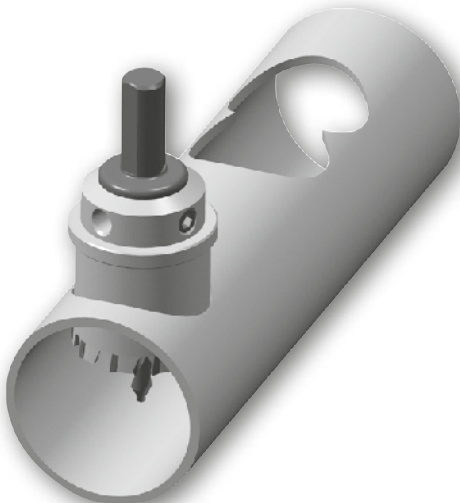

Special tools for special applications on request!



ALFRA TGT-HOLE SAWS – LONG TYPE



Made in Germany by ALFRA

Ø mm	Ø Inches	No. of teeth	Prod.-No. mm
Ø 16.0	5/8"	4	0700160
Ø 17.0		4	0700170
Ø 18.0	11/16"	4	0700180
Ø 19.0	3/4"	4	0700190
Ø 20.0		5	0700200
Ø 21.0	13/16"	5	0700210
Ø 22.0		5	0700220
Ø 23.0	7/8"	5	0700230
Ø 24.0	15/16"	6	0700240
Ø 25.0		6	0700250
Ø 26.0	1"	6	0700260
Ø 27.0	1-1/16"	6	0700270
Ø 28.0		6	0700280
Ø 29.0	1-1/8"	6	0700290
Ø 30.0	1-3/16"	6	0700300
Ø 31.0		8	0700310
Ø 32.0	1-1/4"	8	0700320
Ø 33.0		8	0700330
Ø 34.0	1-5/16"	8	0700340
Ø 35.0	1-3/8"	8	0700350
Ø 36.0		8	0700360
Ø 37.0	1-7/16"	8	0700370
Ø 38.0		8	0700380
Ø 39.0	1-1/2"	8	0700390
Ø 40.0	1-9/16"	10	0700400
Ø 41.0		10	0700410
Ø 42.0	1-5/8"	10	0700420
Ø 43.0	1-11/16"	10	0700430
Ø 44.0		10	0700440
Ø 45.0	1-3/4"	10	0700450
Ø 46.0		10	0700460
Ø 47.0	1-13/16"	10	0700470
Ø 48.0	1-7/8"	10	0700480
Ø 49.0		10	0700490
Ø 50.0	1-15/16"	12	0700500
Ø 51.0	2"	12	0700510
Ø 52.0		12	0700520
Ø 53.0	2-1/16"	12	0700530

Ø mm	Ø Inches	No. of teeth	Prod.-No. mm
Ø 54.0	2-1/8"	12	0700540
Ø 55.0		12	0700550
Ø 56.0	2-3/16"	12	0700560
Ø 57.0	2-1/4"	12	0700570
Ø 58.0		12	0700580
Ø 59.0	2-5/16"	12	0700590
Ø 60.0	2-3/8"	14	0700600
Ø 61.0		14	0700610
Ø 62.0	2-7/16"	14	0700620
Ø 63.0		14	0700630
Ø 64.0	2-1/2"	14	0700640
Ø 65.0		14	0700650
Ø 66.0	2-9/16"	14	0700660
Ø 67.0	2-5/8"	16	0700670
Ø 68.0		16	0700680
Ø 69.0	2-11/16"	16	0700690
Ø 70.0	2-3/4"	16	0700700
Ø 71.0		16	0700710
Ø 72.0	2-13/16"	16	0700720
Ø 73.0	2-7/8"	16	0700730
Ø 74.0	2-15/16"	16	0700740
Ø 75.0		16	0700750
Ø 76.0	3"	18	0700760
Ø 77.0		18	0700770
Ø 78.0	3-1/16"	18	0700780
Ø 79.0	3-1/8"	18	0700790
Ø 80.0		18	0700800
Ø 81.0	3-3/16"	18	0700810
Ø 82.0		18	0700820
Ø 83.0	3-1/4"	18	0700830
Ø 84.0	3-5/16"	20	0700840
Ø 85.0		20	0700850
Ø 86.0	3-3/8"	20	0700860
Ø 87.0	3-7/16"	20	0700870
Ø 88.0		20	0700880
Ø 89.0	3-1/2"	20	0700890
Ø 90.0	3-9/16"	20	0700900
Ø 91.0		20	0700910

Ø mm	Ø Inches	No. of teeth	Prod.-No. mm
Ø 92.0	3-5/8"	20	0700920
Ø 93.0		20	0700930
Ø 94.0	3-11/16"	22	0700940
Ø 95.0	3-3/4"	22	0700950
Ø 96.0		22	0700960
Ø 97.0	3-13/16"	22	0700970
Ø 98.0	3-7/8"	22	0700980
Ø 99.0		22	0700990
Ø 100.0	3-15/16"	22	0701000

HSS-Spare Drill with tapered center tip

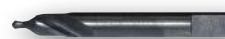

von Ø 20.0 - 59.0	Ø 6x80 mm	0702680
von Ø 60.0 - 100.0	Ø 8x100 mm	0702800

MT Arbors



MT-2 (ab Ø 31.0)	0734002
MT-3 (ab Ø 31.0)	0734003

SDS Arbor



SDS arbor shank (for use with Ø 31 - 59 mm)	060sds6
---	---------

HIGHLY RECOMMENDED ACCESSORIES – COOLANT AND LUBRICANT!

ALFRA 2000

ALFRA 2000 is a fully synthetic cutting oil, developed for high-quality cutting, threading and drilling of metals of any degree of hardness, ferrous metal, steel alloys, stainless steel, copper, aluminium and their alloys.

ALFRA BIO 2000 is free of hydrocarbon, sulphur and chlorine.



ALFRA 3000

Universal metal working oil free of chlorine. High-performance drilling, broaching and cutting fluid, petroleum-based, for moderately difficult and difficult to cut steels. With a high proportion of active ingredients to ensure optimum cutting performance and significantly reduced tool wear. It meets occupational health and safety requirements.

We recommend to use ALFRA 3000 especially for the drilling and threading of high-alloy steel and chrome nickel steel.



ALFRA 4000

Suitable for core drilling applications with ALFRA cutters. Also ideal for twist drilling, thread tapping, reaming, countersinking, and difficult cutting applications. It meets to the requirements of work hygiene and safety.

ALFRA 4000 is a pump spray, free from propellant gas ideal for drilling and tapping of high-alloy, stainless steels; chromium nickel steels; titanium and manganese-carbon steels



	Prod.-No.
Aerosol can 405 ml	21010
5 ltr. Plastic container	21012
60 ltr. Barrel	21021

	Prod.-No.
Aerosol can 520 ml	21030
5 ltr. Plastic container	21031
60 ltr. Barrel	21032

	Prod.-No.
Aerosol can 300 ml	21040



ALFRA TGT-HOLE SAWS – MBS-LIGHT

The TCT Multirange Hole Saw • Registered Utility Model No. 202 03 232 9 • Made in Germany by ALFRA

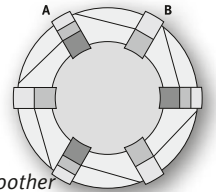
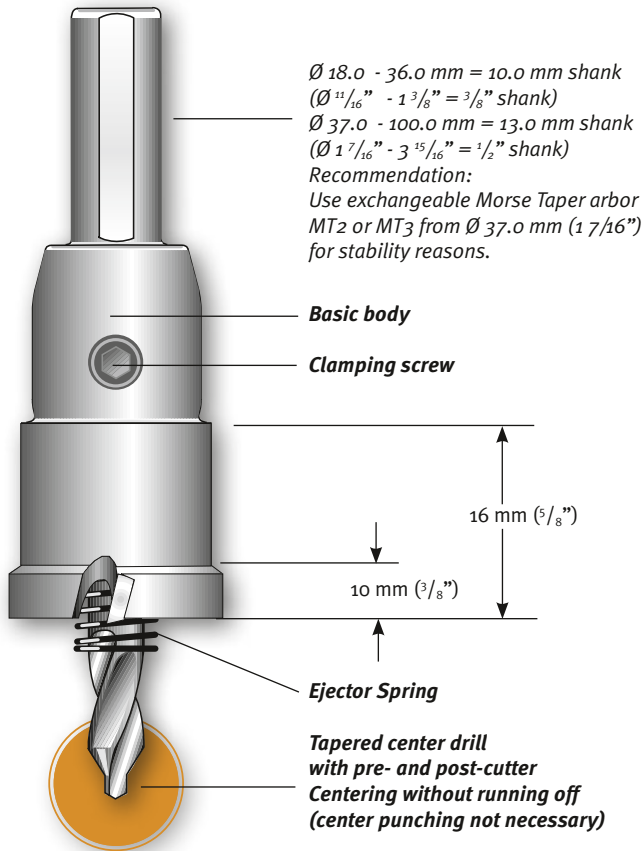

Cutting geometries
 Variable teeth, less
 Vibration, longer tool life, smoother
 cutting.

MBS – for almost limitless use

This TCT Hole Saw is a multi-range Hole Saw for the universal use up to a material thickness of max. 10 mm (3/8") (without ejector spring). Through its solid construction and an enhanced cutting geometry (Registered Utility Model No. 202 03 232 9), an improved cutting behaviour combined with a high cutting capacity and tool life, is achieved.

For the use on flat steel, as well as on pipes and vaulted materials. Cutting of overlapping holes is possible.

For use on stationary and hand drilling machines (recommended up to max. $\varnothing 40 \text{ mm}$; 1 9/16").

- **Portable drilling Machines:** up to 4 mm (1/8") material thickness
- **Stationary drilling Machines:** up to 10 mm (3/8") material thickness (for material thickness over 6 mm (15/64"), it is necessary to settle and empty the chips several times).

In case of heavy operation, we recommend Morse Taper Tool Holders, which are suitable from $\varnothing 37 \text{ mm}$ (1 7/16").

Advantage: All MBS-Light type TCT Hole Saws are equipped with an ejector spring.

The cut material is self-ejecting. The cut material is self-ejecting.

Another special technical feature:

From $\varnothing 37 \text{ mm}$ (1 7/16"), specially hardened tool holders are used to compensate for the torsional power in case of heavy operation which avoids early shearing off of the tool holder shank.

In terms of construction not comparable with any other make.

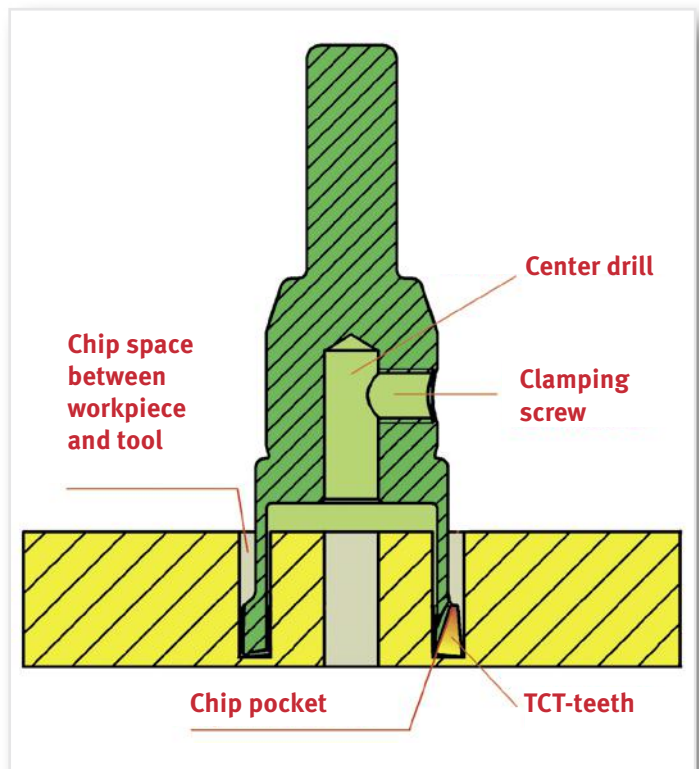



ALFRA TCT-HOLE SAWS – MBS-LIGHT



The TCT Multirange Hole Saw • Registered Utility Model No. 202 03 232 9 • Made in Germany by ALFRA

Ø mm	Ø Inches	No. of teeth	Prod.-No. mm
Ø 18.0	11/16"	6	0730018
Ø 19.0	3/4"	6	0730019
Ø 20.0		6	0730020
Ø 21.0	13/16"	6	0730021
Ø 22.0		6	0730022
Ø 23.0	7/8"	6	0730023
Ø 24.0	15/16"	6	0730024
Ø 25.0		6	0730025
Ø 26.0	1"	6	0730026
Ø 27.0	1-1/16"	6	0730027
Ø 28.0		6	0730028
Ø 29.0	1-1/8"	6	0730029
Ø 30.0	1-3/16"	6	0730030
Ø 31.0		6	0730031
Ø 32.0	1-1/4"	6	0730032
Ø 33.0		6	0730033
Ø 34.0	1-5/16"	6	0730034
Ø 35.0	1-3/8"	6	0730035
Ø 36.0		6	0730036

From Ø 37.0 mm (1-7/16") we recommend the use of MT arbors

Ø 37.0	1-7/16"	6	0730037
Ø 38.0		6	0730038
Ø 39.0	1-1/2"	6	0730039
Ø 40.0	1-9/16"	6	0730040
Ø 41.0		6	0730041
Ø 42.0	1-5/8"	6	0730042
Ø 43.0	1-11/16"	6	0730043
Ø 44.0		6	0730044
Ø 45.0	1-3/4"	6	0730045
Ø 46.0		6	0730046
Ø 47.0	1-13/16"	6	0730047
Ø 48.0	1-7/8"	6	0730048
Ø 49.0		6	0730049
Ø 50.0	1-15/16"	6	0730050
Ø 51.0	2"	6	0730051
Ø 52.0		6	0730052
Ø 53.0	2-1/16"	6	0730053
Ø 54.0	2-1/8"	6	0730054
Ø 55.0		6	0730055
Ø 56.0	2-3/16"	6	0730056
Ø 57.0	2-1/4"	6	0730057
Ø 58.0		6	0730058
Ø 59.0	2-5/16"	6	0730059
Ø 60.0	2-3/8"	8	0730060
Ø 61.0		8	0730061
Ø 62.0	2-7/16"	8	0730062
Ø 63.0		8	0730063
Ø 64.0	2-1/2"	8	0730064
Ø 65.0		8	0730065
Ø 66.0	2-9/16"	8	0730066
Ø 67.0	2-5/8"	8	0730067
Ø 68.0		8	0730068
Ø 69.0	2-11/16"	8	0730069
Ø 70.0	2-3/4"	8	0730070
Ø 71.0		10	0730071
Ø 72.0	2-13/16"	10	0730072
Ø 73.0	2-7/8"	10	0730073
Ø 74.0	2-15/16"	10	0730074
Ø 75.0		10	0730075
Ø 76.0	3"	10	0730076
Ø 77.0		12	0730077
Ø 78.0	3-1/16"	12	0730078
Ø 79.0	3-1/8"	12	0730079
Ø 80.0		12	0730080
Ø 81.0	3-3/16"	12	0730081

Ø mm	Ø Inches	No. of teeth	Prod.-No. mm
Ø 82.0		12	0730082
Ø 83.0	3-1/4"	12	0730083
Ø 84.0	3-5/16"	12	0730084
Ø 85.0		12	0730085
Ø 86.0	3-3/8"	14	0730086
Ø 87.0	3-7/16"	14	0730087
Ø 88.0		14	0730088
Ø 89.0	3-1/2"	14	0730089
Ø 90.0	3-9/16"	14	0730090
Ø 91.0		14	0730091
Ø 92.0	3-5/8"	14	0730092
Ø 93.0		14	0730093
Ø 94.0	3-11/16"	14	0730094
Ø 95.0	3-3/4"	14	0730095
Ø 96.0		14	0730096
Ø 97.0	3-13/16"	14	0730097
Ø 98.0	3-7/8"	14	0730098
Ø 99.0		14	0730099
Ø 100.0	3-15/16"	14	0730100



Drilling in checker sheet



Drilling in square profiles



Drilling in flat steel



Drilling in pipes

HSS-Spare Drill

with tapered center tip

from Ø 18.0 - 60.0	Ø 6x50 mm	0602650
from Ø 61.0 - 100.0	Ø 8x50 mm	0602850

(old design)

MT Arbors



MT-2 (Ø 31.0 - 100.0 mm)	0734002
MT-3 (Ø 31.0 - 150.0 mm)	0734003

Weldon adaptor



from Ø 37.0 mm	060WD
----------------	-------

(inc. ejector pin Prod. No. 1950500)

Spare Ejector

For tapered center drill

from Ø 18.0 - 100.0 mm Ø 6 mm	0732006
from Ø 61.0 - 100.0 mm Ø 8 mm	0732008

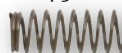

B



ALFRA TCT-HOLE SAWS – MBS-PRO

The TCT Multi-Range Hole Saw • Made in Germany by ALFRA

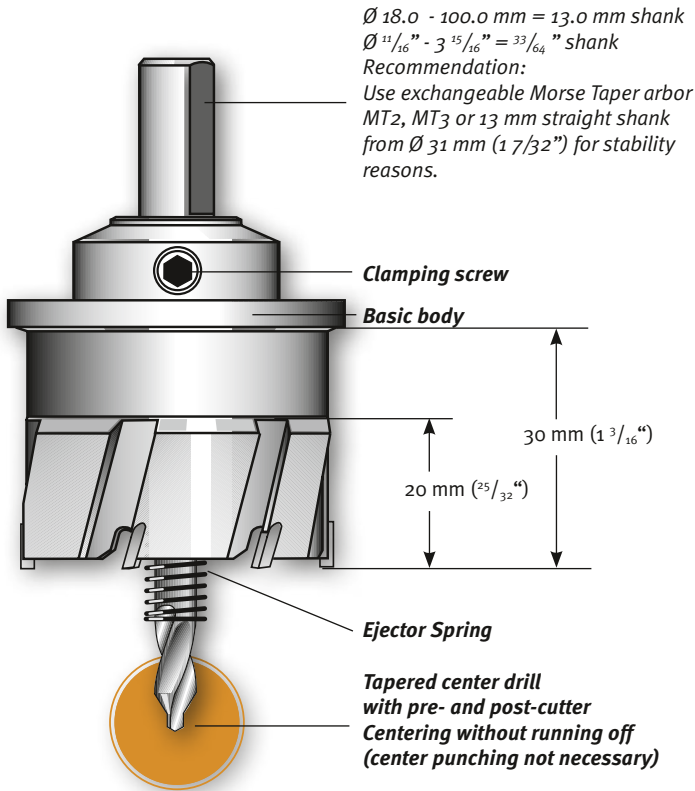

Cutting geometries
 Variable teeth, less
 Vibration, longer tool life, smoother
 cutting.

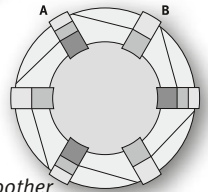

MBS-Multirange Hole Saws for universal use. **Max. cutting depth 20 mm** ($\frac{25}{32}''$)

Suitable for flat materials but also for pipes and curved surfaces. Cutting of overlapping holes is possible. CAD optimized precision tools with high cutting performance and durability.

For use on stationary and portable drilling machines (recommended up to max. $\varnothing 40 \text{ mm}$; $1\frac{9}{16}''$)

- **Portable drilling Machines:** up to 6 mm ($\frac{15}{64}''$) material thickness
- **Stationary drilling Machines:** up to 20 mm ($\frac{25}{32}''$) material thickness at cutting depths from 6 mm ($\frac{15}{64}''$) we recommend clearing the chips.

MBS hole saws can be resharpened, and it is possible to replace broken out teeth depending on the condition of the hole saw.

Advantages: All Alfra TCT Hole Saws MBS-Pro type are equipped with an ejector spring.

The cut material is self-ejecting. The cut material is self-ejecting.

Another special technical feature:
 From $\varnothing 31 \text{ mm}$ ($1\frac{7}{32}''$), we use specially hardened tool holders to compensate for the torsional power in case of heavy operation, which avoids early shearing off of the tool holder shank.

In terms of construction not comparable with any other make.

MBS – for almost limitless use

e.g., on Rotabest Magnetic Drilling Machine (with MT2 or MT3 – arbors) and Weldon adaptor Prod.-No. o6oWD on Machines with Weldon Shank.





ALFRA TGT-HOLE SAWS – MBS-PRO



The TGT Multi-Range Hole Saw • Made in Germany by ALFRA

Ø mm	Ø Inches	No. of teeth	Prod.-No. mm
Ø 18.0	11/16"	6	0760018
Ø 18.6		6	07600186
Ø 19.0	3/4"	6	0760019
Ø 20.0		6	0760020
Ø 20.4		6	07600204
Ø 21.0	13/16"	6	0760021
Ø 22.0		6	0760022
Ø 22.5		6	07600225
Ø 23.0	7/8"	6	0760023
Ø 24.0	15/16"	6	0760024
Ø 25.0		6	0760025
Ø 26.0	1"	6	0760026
Ø 27.0	1-1/16"	6	0760027
Ø 28.0		6	0760028
Ø 28.3		6	07600283
Ø 29.0	1-1/8"	6	0760029
Ø 30.0	1-3/16"	6	0760030
As from Ø 31.0 mm (1-7/32") we recommend the use of MT arbors			
Ø 31.0		6	0760031
Ø 32.0	1-1/4"	6	0760032
Ø 33.0		6	0760033
Ø 34.0	1-5/16"	6	0760034
Ø 35.0	1-3/8"	6	0760035
Ø 36.0		6	0760036
Ø 37.0	1-7/16"	6	0760037
Ø 38.0		6	0760038
Ø 39.0	1-1/2"	6	0760039
Ø 40.0	1-9/16"	6	0760040
Ø 41.0		6	0760041
Ø 42.0	1-5/8"	6	0760042
Ø 43.0	1-11/16"	6	0760043
Ø 44.0		6	0760044
Ø 45.0	1-3/4"	6	0760045
Ø 46.0		6	0760046
Ø 47.0	1-13/16"	6	0760047
Ø 48.0	1-7/8"	6	0760048
Ø 49.0		6	0760049
Ø 50.0	1-15/16"	6	0760050
Ø 51.0	2"	6	0760051
Ø 52.0		6	0760052
Ø 53.0	2-1/16"	6	0760053
Ø 54.0	2-1/8"	6	0760054
Ø 55.0		6	0760055
Ø 56.0	2-3/16"	6	0760056
Ø 57.0	2-1/4"	6	0760057
Ø 58.0		6	0760058
Ø 59.0	2-5/16"	6	0760059
Ø 60.0	2-3/8"	8	0760060
Ø 61.0		8	0760061
Ø 62.0	2-7/16"	8	0760062
Ø 63.0		8	0760063
Ø 64.0	2-1/2"	8	0760064
Ø 65.0		8	0760065
Ø 66.0	2-9/16"	8	0760066
Ø 67.0	2-5/8"	8	0760067
Ø 68.0		8	0760068
Ø 69.0	2-11/16"	8	0760069
Ø 70.0	2-3/4"	8	0760070
Ø 71.0		10	0760071
Ø 72.0	2-13/16"	10	0760072
Ø 73.0	2-7/8"	10	0760076
Ø 74.0	2-15/16"	10	0760074
Ø 75.0		10	0760075

Ø mm	Ø Inches	No. of teeth	Prod.-No. mm
Ø 76.0	3"	10	0760076
Ø 77.0		12	0760077
Ø 78.0	3-1/16"	12	0760078
Ø 79.0	3-1/8"	12	0760079
Ø 80.0		12	0760080
Ø 81.0	3-3/16"	12	0760081
Ø 82.0		12	0760082
Ø 83.0	3-1/4"	12	0760083
Ø 84.0	3-5/16"	12	0760084
Ø 85.0		12	0760085
Ø 86.0	3-3/8"	14	0760086
Ø 87.0	3-7/16"	14	0760087
Ø 88.0		14	0760088
Ø 89.0	3-1/2"	14	0760089
Ø 90.0	3-9/16"	14	0760090
Ø 91.0		14	0760091
Ø 92.0	3-5/8"	14	0760092
Ø 93.0		14	0760093
Ø 94.0	3-11/16"	14	0760094
Ø 95.0	3-3/4"	14	0760095
Ø 96.0		14	0760096
Ø 97.0	3-13/16"	14	0760097
Ø 98.0	3-7/8"	14	0760098
Ø 99.0		14	0760099
Ø 100.0	3-15/16"	14	0760100

For drilling stainless steel from Ø 76.0 mm we recommend using Rotabest AL cutters (Prod.-No. 200205....)



Drilling structured sheet metals



Drilling tubes

HSS-Spare Drill with tapered center tip

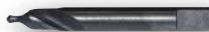

from Ø 18.0 - 60.0 Ø 6x80 mm 0732680
 from Ø 61.0 - 100.0 Ø 8x80 mm 0732880
 (old design)

MT Arbors



MT-2 (Ø 31.0 - 100.0 mm) 0734002
 MT-3 (Ø 31.0 - 100.0 mm) 0734003

Weldon adapter



from Ø 31.0 mm 060WD
 (incl. ejector pin Prod. No. 1950500)

Spare Ejector

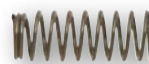

For tapered center drill
 from Ø 15.2 - 100.0 Ø 6 mm 0762006
 suitable for spare drill Ø 6 mm



Drilling flat steels

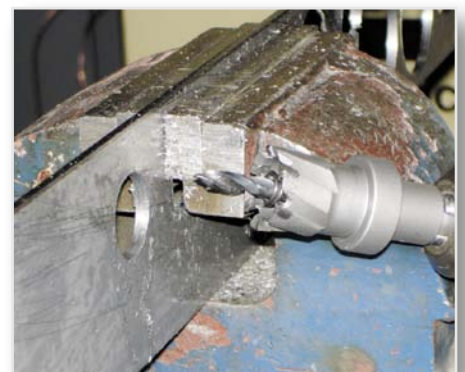

Free-hand drilling up to Ø 30 mm

B



ALFRA TGT-HOLE SAWS – FRP TYPE

The TCT Multi-Range Hole Saw • Made in Germany by ALFRA

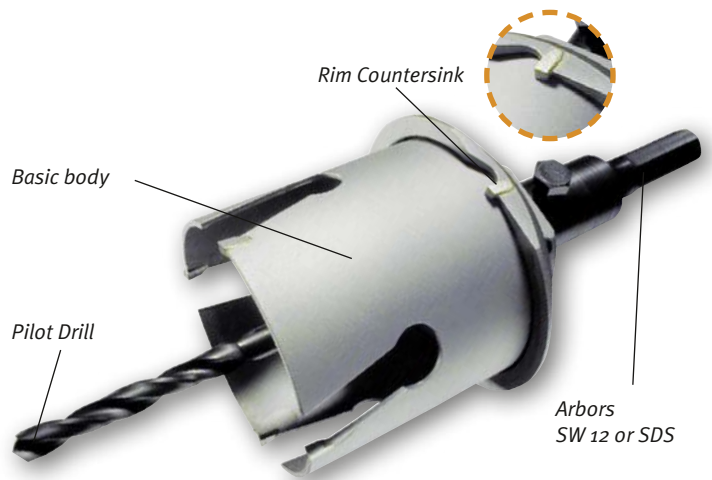
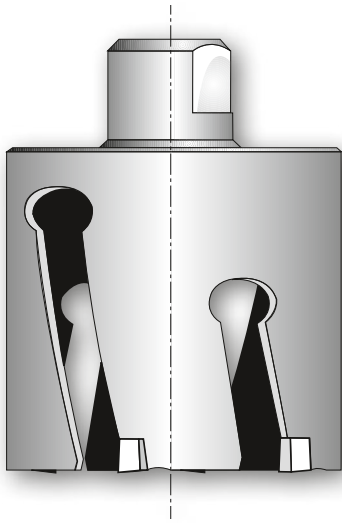

Prod.-No. 0740068060 – FRP Ø 68 mm with tool holder and rim countersink

Cutting depth 60 mm (2-3/8")

- Specially designed for wood, plain, laminated and coated chip board, plywood, paper-base laminate, PVC, glass fibre reinforced plastic, gas concrete, Ytong stone, plasterboard, hollow gauged brick/stones.
- No blocking due to optimal cutting geometry.
- Simple drill core removal based on new chip space design.
- In the event of a tooth breaking, it can easily be replaced and re-sharpened.
- Only use when rotating, switch off hammer action.
- Ideal for electricians, plumbers and heating engineers, carpenters and cabinet makers, stair construction and kitchen furniture fitters.



Perfect assembly of sockets in e.g. wood, gypsum plaster board,...

ALFRA TGT-HOLE SAWS – FRP MULTI-TOOTH

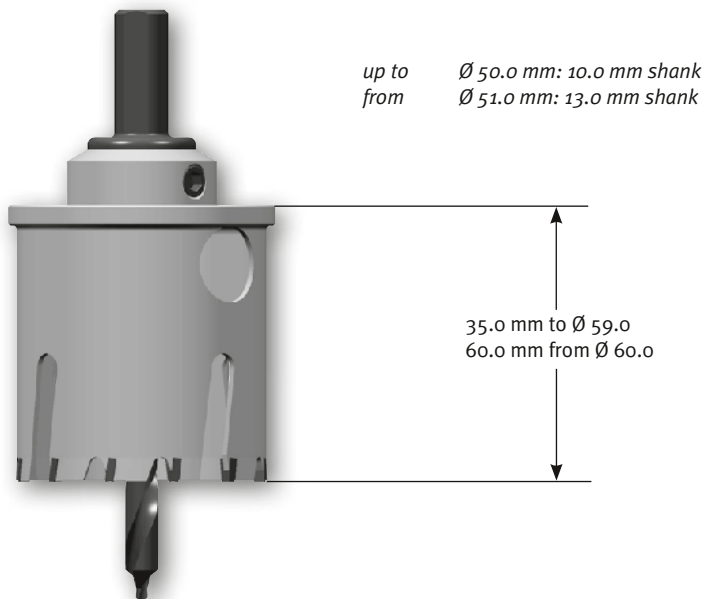

with arbor shank

- Cutting depth 35.0/60.0 for sandwich-composite material, wood and chipboard coated with insulation and sheet metal (also stainless), e.g., counters and refrigerators.



Please indicate material and thickness!



ALFRA TGT-HOLE SAWS – FRP TYPE



The TCT Multi-Range Hole Saw • Made in Germany by ALFRA

Ø mm	TCT-Hole Saws FRP inch	single drill bit, cutting depth 60 mm	Prod.-No.	Ø mm	TCT-Hole Saws FRP Multi-tooth	Prod.-No.
25.0		Sanitary and heating pipes	0740025060	40.0	Sanitary drain pipes	0750040040
25.0		Sanitary and heating pipes	0740025060	40.0	Water and heating pipes	0750045040
35.0	1-3/8"	Sanitary and heating pipes	0740035060	50.0	with insulation	0750050040
		Cavity wall branch box, halogen reflector lamp		55.0		0750055040
40.0		Sanitary drain pipes	0740040060	60.0		0750060060
45.0		Water and heating pipes	0740045060	63.0	Switch boxes, diameter 60 mm	0750063060
50.0		with insulation	0740050060	65.0		0750065060
55.0		Recessed lights Ø 55 mm	0740055060	68.0	socket drill	0750068060
58.0		Recessed lights Ø 58 mm	0740058060	70.0		0750070060
60.0		Recessed lights Ø 60 mm	0740060060	74.0	Junction boxes, diameter 70 + 74 mm	0750074060
63.0		Switch box Ø 60 mm	0740063060	75.0		0750075060
65.0		Cavity wall box Ø 65 mm	0740065060	80.0	Junction boxes	0750080060
68.0		Cavity wall box Ø 68 mm	0740068060	85.0		0750085060
70.0		Cavity wall branch boxes Ø 70 mm	0740070060	90.0		0750090060
74.0		Cavity wall branch box Ø 74 mm	0740074060	95.0		0750095060
				100.0		0750100060
80.0		Junction boxes, cable gland covers, Recessed lights Ø 80 mm	0740080060	105.0	Discharge air pipes	0750105060
85.0		Recessed lights Ø 85 mm	0740085060		Intermediate sizes and other cutting depths on request	0759
90.0		Recessed lights Ø 90 mm	0740090060			
105.0		Discharge air pipes	0740105060			

HSS spare drill for FRP Multi-tooth

Ø 30.0 - 59.0 mm = 8 x 80	0752880
Ø 61.0 - 105.0 mm = 8 x 100	0752800



Rim countersink for Ø 68 mm 0741068000



Tool Holder wrench size 12 0742000001



Tool Holder SDS 0742000002



Spare center drill HSS 7.2 mm 0742000003

FRP Hole Saw Set Electrician

Content: 0743000001
 1 each of Ø 35/ 68/74
 1 Tool Holder wrench size 12
 1 HSS drill

FRP Hole Saw Set Lighting

Content: 0743000002
 1 each of Ø 35/60/68/80/85 mm
 1 Tool Holder wrench size 12
 1 HSS drill



Prod.-No. 0743000001



Prod.-No. 0743000002

B



ALFRA PRECISION MULTI-STEP DRILLS

- ▶ SPIRAL GROOVED, EACH STEP WITH AXIAL AND RADIAL RELIEF GRINDING ACCORDING TO ITS DIAMETER
- ▶ LASER-ETCHED SCALE IN THE CHIP SPACE
- ▶ SPECIAL DRILL TIP ENABLES CENTERING AND DRILLING EVEN THROUGH THIN-WALLED MATERIALS
- ▶ BURR-FREE DRILLING WITH NO DEFORMATION OF THE SHEET
- ▶ REGRINDABLE
- ▶ AVAILABLE IN HSS AND HSS WITH TiAIN COATING

B





MULTI-STEP DRILLS – HSS DM 03



More precise hole diameter through cylindrical steps. Hole deburring through the next step.

Application area:

The ideal tool for sheet metal forming, for the electrical industry, HVAC or the common engineering or the switchboard industry.

Suitable for all materials such as nonferrous metals, stainless steel sheets, thermoplastic and thermosetting plastics, as well as for steel sheets up to a max. material thickness of 6 mm.

With the Multi-Step Drills, sheet metals can be centered, drilled and subsequently deburred in one work step.

- A break of the drill tip mostly occurs through high feed forces at the start of the drilling operation. Multi-step drills with fixed drill tips are worthless then. A broken center drill in an ALFRA multi-step drill can be easily replaced. This more than compensates for the higher price.
- Each stage is equipped with a radially adjusted relief grinding corresponding to its diameter.
- Each stage is provided with an axial relief grinding and a relief angle on its cutting edge.
- All step diameters are laser marked on the tool.

Benefits of multi-step drills with keyway and 3 cutting edges:

- The keyway allows the drill to make a chipping cut during drilling for better chip removal.
- The special keyway geometry, arranged around the drill, makes for a longer cutting edge compared to the usual straight groove and noticeably easier cutting.
- Spiral cut chip spaces guarantee an absolute running smoothness and a high cutting capacity.

Tip:

The tool life can be considerably prolonged by using of ALFRA Cutting Spray or ALFRA Coolant Stick.

Advantages of TiAlN hard coating:

- Suitable for use on very hard materials (VA).
- Offers optimal tool life with the same use at the highest cutting speeds.
- Very high microhardness HV 0.05 of 3200 – so that the blue-black hard coating is more than 20% harder than conventional gold-yellow TIN coating.
- Maximum working temperature: 800°C.

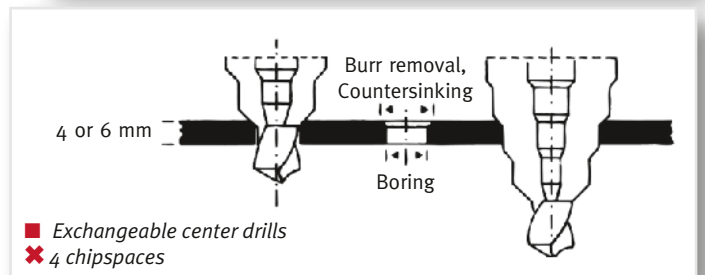

Description	Shank Ø	Prod.-No.
AMS	10.0	08080

For general machine construction, drills circular holes in metals up to 4 mm thick, through application with hand drills, indispensable on the work-site.
3 chip spaces, spiral grooved, replaceable center drill
Steps Ø 9 - 12 - 15 - 18 - 21 - 24 - 27 - 30 - 33 - 36 mm
(Step „40“ is for deburring)

AMS – TiAlN coated	10.0	08081
---------------------------	------	-------

3 chip spaces, spiral grooved, replaceable center drill
TiAlN coated
Steps Ø 9 - 12 - 15 - 18 - 21 - 24 - 27 - 30 - 33 - 36 mm
(Step „40“ is for deburring)

AM 1	12.0	08002
-------------	------	-------

Steps Ø 25 - 28 - 31 - 34 - 37 - 40 - 43 - 46 - 49 - 52 - 55 - 58 mm

PVD	10.0	08003
------------	------	-------

For the electrical industry, matched to holes for armoured conduit thread clearance holes, saves considerable time when producing borings for PG
Steps Ø PG 7 - PG 9 - PG 11 - PG 13 - PG 16 - PG 21 - 33 mm - PG 29 - 40 mm



Prod.-No. 08080 ■



Prod.-No. 08081 ■



Prod.-No. 08002 ■ ✗



Prod.-No. 08003 ■ ✗



MULTI-STEP DRILLS - HSS DM 03

More precise hole diameter through cylindrical steps. Hole deburring through the next step.

Description	Shank Ø	Prod.-No.
PVD-TiN-coated	10.0	08004
PVK Like PVD, but for armoured conduit thread core hole PG Steps Ø PG 7 - PG 9 - PG 11 - PG 13 - PG 16 - PG 21	10.0	08005
SVB Pre-drill specifically for punches & dies Steps Ø 8.5 - 11.5 - 12.5 - 16.5 - 21.0	10.0	08016
DKS 32 3 chip spaces, spiral grooved, replaceable center drill Clearance holes Ø 12.5 - 16.5 - 20.5 - 25.5 - 32.5 Core holes Ø 10.5 - 14.5 - 18.5 - 23.5 - M12 - M16 - M20 - M25 - M32	12.0	08082
DKS 32 TiAlN coated 3 chip spaces, spiral grooved, replaceable center drill Clearance holes Ø 12.5 - 16.5 - 20.5 - 25.5 - 32.5 Core holes Ø 10.5 - 14.5 - 18.5 - 23.5 - M12 - M16 - M20 - M25 - M32	12.0	08083
DKS 40 3 chip spaces, spiral grooved, replaceable center drill, for metric borings acc. to EN, Core - and clearance holes M 10 - M 40 Steps Ø 10.5 - 12.5 - 14.5 - 16.5 - 18.5 - 20.5 - 25.5 - 32.5 - 38.5 - 40.5	10.0	08084
DKS 40 - TiAlN coated 3 chip spaces, spiral grooved, replaceable center drill For metric borings acc. to EN 50262 Core - and clearance holes M 10 - M 40 Steps Ø 10.5 - 12.5 - 14.5 - 16.5 - 18.5 - 20.5 - 23.5 - 25.5 - 32.5 - 38.5 - 40.5	10.0	08085
DKI-VA 4 chip spaces, replaceable center drill of HSS-Co 5 steel. For stainless steel to 3 mm thick Core - and clearance holes M 10 - M 40 Steps Ø 10.5 - 12.5 - 14.5 - 16.5 - 18.5 - 20.5 - 23.5 - 25.5 - 32.5 - 38.5 - 40.5	10.0	08032
Spare center drill suitable for AMS - PVD - PVK - DKI - DKS		08007
Spare center drill TiAlN suitable for AMS - PVD - PVK - DKI - DKS		08008



Prod.-No. 08004 ■ ✕



Prod.-No. 08005 ■ ✕



Prod.-No. 08016

Pre-drill specifically for punches & dies



Prod.-No. 08082 ■



Prod.-No. 08083 ■



Prod.-No. 08084 ■



Prod.-No. 08085 ■



Prod.-No. 08032 ■ ✕



Prod.-No. 08007



Prod.-No. 08008

■ Replaceable center drill ✕ 6 With 4 chip spaces





MULTI-STEP DRILLS – HSS DM 03



More precise hole diameter through cylindrical steps. Hole deburring through the next step.

Standard execution with 2 chip spaces, spiral grooved.

- More precise hole diameter through cylindrical steps.
- Immediate deburring through the next step
- Drilling of sheet metals as thin as 4 mm possible.
- Use coolant stick!
- The keyway allows the drill to make a chipping cut during drilling for better chip removal.
- Longer cutting edge compared to the usual straight groove and noticeably easier cutting.
- Laser-etched scale in the chip space to indicate the bore diameter achieved.

Description	Bore range	Shank Ø	Length	Prod.-No.
AM-12	4 - 12 mm x 1 mm	6.0	70 mm	08070
AM-20	6 - 20 mm x 2 mm	9.0	77 mm	08071
AM-30	6 - 30 mm x 2 mm	10.0	98 mm	08072

Set in plastic case 08073

Contents:

1 of each Type AM-12/AM-20/AM-30

High-performance coolant stick 09012



Prod.-No. 08072

Prod.-No. 09012

Standard values for the use of ALFRA Multi-step drills

This drill was developed to bore perfectly round and deburred holes in sheet metal from 4 - 6 mm thick. The transition forms a radius which serves to deburr or bevel the hole at the same time. While conical one-lip bits drill a slightly tapered hole, our ALFRA multi-step drill achieves a cylindrical hole. The tools have axial-radial relief grindings and can be lightly reground on the breast of the cutting tooth.

We recommend the use of pillar drilling machines, however, the small ALFRA Multi-step drills can be used on adjustable hand drilling machines. Sufficient cooling using ALFRA coolant stick or a bore emulsion is imperative.

Speed chart rpm

Type		sheet steel S235	stainless steel sheets	non-ferrous metals	plastics (soft)
AM	drill	800	360	1000	1000
	countersink	500 - 180	50 - 70	800 - 400	1000 - 400
AM-1	drill	800	360	1000	1000
	countersink	200 - 100	100 - 50	500 - 200	600 - 250
PVD+PVK+DKI	drill	800	360	1000	1000
	PVD-VA + SVB	countersink	400 - 200	200 - 100	800 - 500



Prod.-No. 08073



PRECISION CONICAL ONE-LIP BITS - HSS DM 05

With laser-etched scale

ALFRA Precision Conical One-Lip Bits are the ideal tools for general sheet metal working. Fields of applications include HVAC, electronic industries, engineering and panel building.

To be used on non-ferrous metals, stainless steels, thermo- and duroplastic plastics, as well as on all common sheet steels up to a material thickness of max. 4 mm. With ALFRA Conical One-Lip Bits, you can center, spot drill and bore up in one work step.

If treated carefully, can be reground many times.

The tool life can considerably be prolonged by using ALFRA Cutting Oil or Coolant Stick.

Packing: separately in plastic box with operation manual.

Size	Range	Shank-Ø	Prod.-No.
1	3.0 - 14.0	6.0	09001
2	6.0 - 20.0	8.0	09002
3	16.0 - 30.5	10.0	09003
4	26.0 - 40.0	12.0	09004
5	35.0 - 50.0	12.0	09005
6	46.0 - 60.0	13.0	09006
7 L	4.0 - 30.5	10.0	09007
8*	6.0 - 22.5	8.0	09008
Set 1	Size. 1 + 2 + 3 + Stiff		09009

Coolant stick, separately 09011

*Special Antenna-Bit

- Conical one-lip bit with cylindrical end section to drill holes for car antennas.
- Burr-free, no deformation, no countersinking, dimensional accuracy
- Size 6.0 - 22.5 mm.

Precision Conical One-Lip Bit Set

Prod.-No.
09009

Tin box

Contents:

- 1 x Size 1
- 1 x Size 2
- 1 x Size 3



Prod.-No. 09001



Prod.-No. 09002



Prod.-No. 09003



Prod.-No. 09004



Prod.-No. 09005



Prod.-No. 09006



Prod.-No. 09007



Prod.-No. 09008*



Prod.-No. 09009

ALFRA SABRE SAW BLADES FOR PROFESSIONAL USE

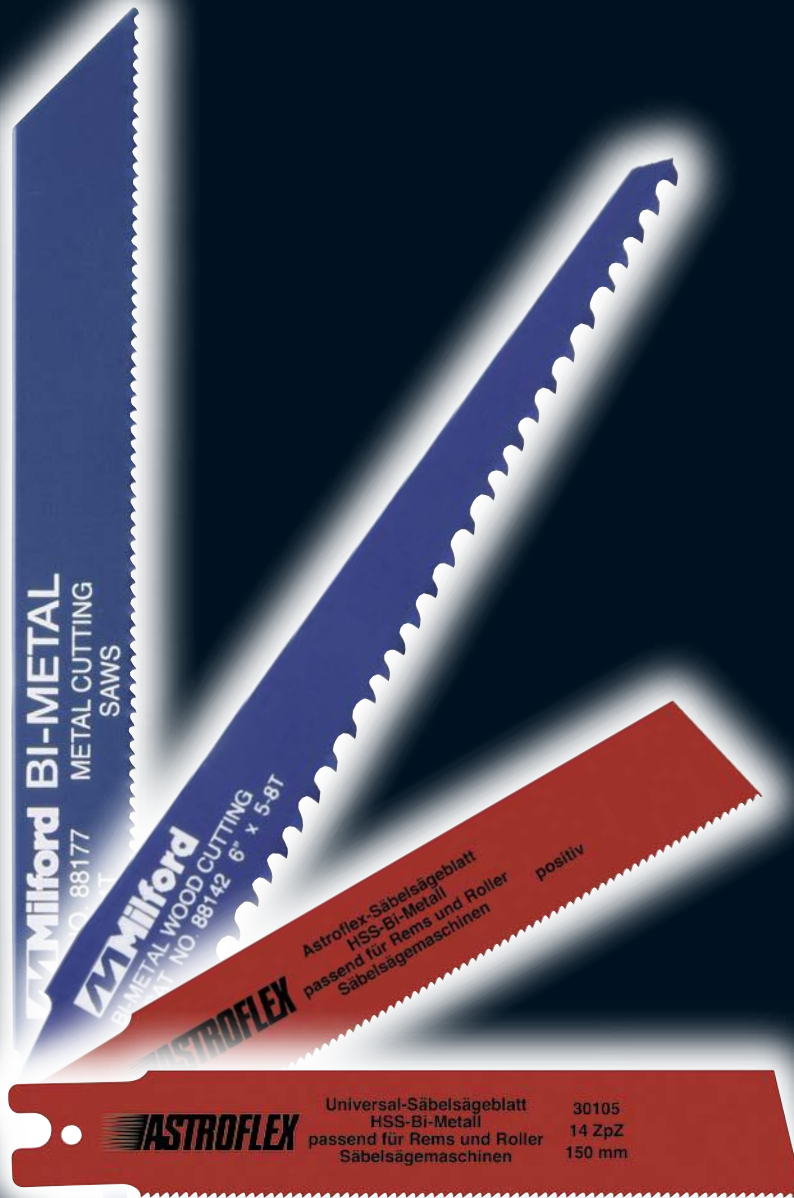

B





ORIGINAL ASTROFLEX® - HSS-BI-METAL SABRE SAW BLADES

For Rems- and Roller Sabre Sawing Machines

ALFRA-Special-Sabre-Saw Blades can be used problem-free on these machines. Made of HSS-Bi-Metal, heat treated to the point.

- Made of high alloy HSS-Bi-Metal
- Heat treated to the point
- Highest heat hardness and wear resistance
- Tothing in crossed version

For pipes

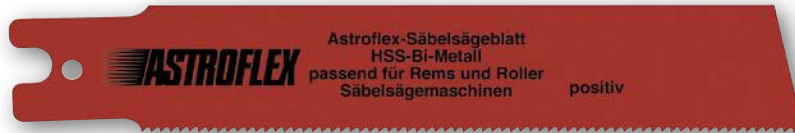

Application range	Steel quality	Length	Width	Thickness	Teeth per inch	Blade No.	Alfra Prod.- No.
Pipes up to Ø 2"	HSS-Bi-Metal	140 mm	25 mm	1.6 mm	8	88140-8	30089

for free-hand and flush cutting



For free-hand and flush cutting	HSS-Bi-Metal	150 mm	25 mm	1.1 mm	14		30105
	HSS-Bi-Metal	200 mm	25 mm	1.1 mm	14		30103
e. g. refurbishing, on walls and overhead	HSS-Bi-Metal	300 mm	25 mm	1.1 mm	14		30104

Packaging unit: 5 pieces

ALFRA - JIGSAW BLADES

Suitable for pneumatic saws as e. g. SIG and Flex-sheet Metal-Tiger Saws

Made of HSS Bi-Metal for burr- and distortion-free cutting of thin sheet metals and plates, as well as for pipes in ventilation and air condition constructions. Precise crossing, highest endurance.



Prod.-No. 31014 - 31017



Prod.-No. 31018 - 31021

Application range	Length mm	Thickness mm	Width mm	Teeth inch	Prod.-No.
For sheet metals as from 1.1 mm thickness, plastic up to 3 mm, wood up to 5 mm	96	0.6	12.5	14	}
	96	0.6	12.5	18	
For sheet metals 0.7 - 1.1 mm thickness	96	0.6	12.5	24	31016
For sheet metals up to 0.7 mm thickness	96	0.6	12.5	32	31017
For sheet metals as from 1.1 mm thickness, plastic up to 3 mm, wood up to 5 mm	97	0.6	12.5	14	}
	97	0.6	12.5	18	
For sheet metals 0.7 - 1.1 mm thickness	97	0.6	12.5	24	31020
For sheet metals up to 0.7 mm thickness	97	0.6	12.5	32	31021

Attention: do not use any pressure, feed only with dead weight of machine.

ULTRA – METAL HAND SAW BLADES



Types

FLEX: High-Carbon Steel Blade

Economical blade, especially designed for aluminium profiles or wood.

MAJOR: High-Speed Steel

Universally usable and partially heat treated blade, particularly made for aluminium, steel sheets and steel profiles.

RECORD: HSS-Cobalt steel

Fully hardened blade for guided, precise cuts made of HSS steel with a high cobalt content.

BI-HARD: High-Speed Cobalt Steel

Blade with hardened tooth tips, therefore semi-flexible with high hardness, made from HSS steel with high Cobalt content. Designed for stainless steel sheets and steel profiles.

BI-METAL: High-Speed Steel with Bi-Metal Strip

Blade with high durability and heat resistance for flexible and robust applications, such as for steel pipes and stainless steel sheets.



Type	No. of teeth/Inches		Prod.-No.
FLEX	18 T	Wavy Set	3300F18
FLEX	24 T	Wavy Set	3300F24
FLEX	32 T	Wavy Set	3300F32
MAJOR	18 T	Raker Set	3300M18
MAJOR	24 T	Raker Set	3300M24
MAJOR	32 T	Raker Set	3300M32
RECORD	18 T	Raker Set	3300R18
RECORD	24 T	Raker Set	3300R24
RECORD	32 T	Raker Set	3300R32

Type	No. of teeth/Inches		Prod.-No.
BI-HARD	18 T	Raker Set	3300BIH18
BI-HARD	24 T	Raker Set	3300BIH24
BI-HARD	32 T	Raker Set	3300BIH32
BI-METAL	18 T	Wavy Set	3300BiM18
BI-METAL	24 T	Wavy Set	3300BiM24
BI-METAL	32 T	Wavy Set	3300BiM32

- Customer brand execution in colour, imprint and packaging from 5.000 pieces possible
- Packaging unit: 100 pieces

ALFRA MACHINE SAW BLADES – HSS DM 05

For Hacksawing machines

- You can use the efficiency of the whole machine with these machine saw blades.
- For sawing solid material, pipes and profiles of all strengths.
- Also for high-strength steels
- With parabolic tooth against early break
- Sharp-edged and wear-resistant, with fine carbide repartition in micro structure
- Straightened by master hand
- For all types of machines



Dimension mm	available toothing tpt			Prod.-No.
300 x 25 x 1.5	8	10	14	33010
350 x 30 x 1.5	6	8	10 14	33011
350 x 30 x 2.0	4	6	8 10	33012
400 x 30 x 1.5	6	8	10 14 18	33013
400 x 30 x 2.0	4	6	8 10	33014
450 x 30 x 2.0	4	6	8 10	33015
450 x 35 x 2.0	4	6	8 10	33016
450 x 40 x 2.0K	4	6	8 10	33017
500 x 40 x 2.0	4	6	8 10	33018
575 x 50 x 2.5K	3	4	6	33019
650 x 55 x 2.5K	3	4	6	33020
700 x 55 x 2.5K	3	4	6	33021

K = Kasto with displaced side holes
 Other dimensions and toothings on request.
 Length measured from hole center to center.
 Packaging unit: 10 pieces

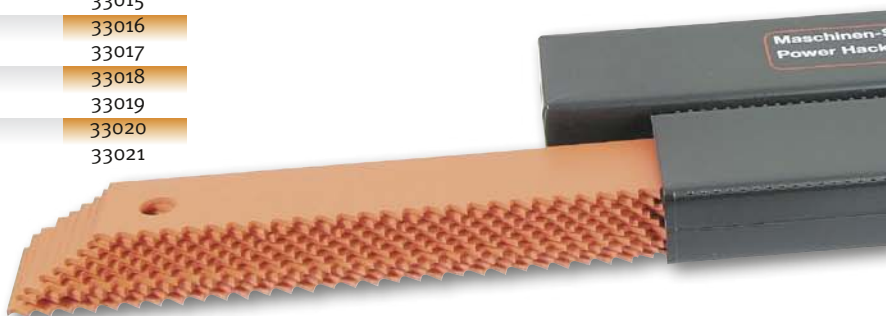

B



COOLANT-CUTTING, DRILLING, BROACHING OILS

RIXOL-2000

Coolant concentrate

- Universal use for sawing and drilling of steel, stainless steel, cast iron, nonferrous metal and aluminium alloys.
- Water emulsive, contains mineral oil, rot-proof, stable solution.
- Provides good rust protection and lubrication. Causes no irritation of the skin.
- No smoke development and no coagulation.
- Factor I for hand refractometer.
- Mixture: Cutters 8 - 10%, Circular saws 5 - 12%, Band saws 6 - 20 %

Prod.-No.

20 ltr. Plastic container

21001

ALFRA 2000

High performance cutting oil

- ALFRA BIO 2000 is an entirely synthetic cutting oil, developed for the metal working industry for core drilling, turning, drilling, milling, reaming, countersink, rubbing, tapping
- Ideally qualified for all steel and steel alloys, chrome-nickel steel, copper, aluminium alloys.
- ALFRA BIO 2000 doesn't contain any hydrocarbon and is chlorine free.
- With special high pressure and anti wear additives.
- With corrosion and rust protection.
- Increases tool life up to 200 % and shortens operating time, reduces the number of rejects.

Prod.-No.

Can 405 ml

21010

5 ltr. Plastic container

21012

60 ltr. Barrel

21021

High-performance coolant stick

09012

ALFRA 3000

High performance Cutting Oil Spray

- For the most difficult working procedures like core drilling, drilling, turning, tapping, reaming, countersink, rubbing
- With special high pressure and anti wear additives.
- For usage of high alloyed stainless steel, chrome-nickel steel and its alloys, titanium and manganese carbon steel.
- Qualified for non-ferrous- and light metals.
- Increases tool life up to 200 %, shortens operating time. Reduces the number of rejects.
- Sticks on surfaces, therefore it's qualified for "over head works" on walls and ceilings.

Prod.-No.

Tin 520 ml

21030

5 ltr. Plastic container

21031

60 ltr. Barrel

21032

ALFRA 4000

High Performance Cutting Oil Spray

- Suitable for core drilling applications with ALFRA cutters. Also ideal for twist drilling, thread tapping, reaming, countersinking, and difficult cutting applications
- For use on: common steels; high-alloy, stainless steels; chromium nickel steels; titanium and manganese-carbon steels
- 100% pure active substance
- Optimal cutting performance
- For working on walls and ceilings
- Free from propellant gas
- Free from chlorine and solvent
- No dangerous substance
- Pump spray
- Optimal dosing quantity

Prod.-No.

Can 300 ml

21040



Prod.-No. 21001



Excellently suited for Rotabest® magnetic drills, as it is water-mixable.



Prod.-No. 09012



Prod.-No. 21010



Prod.-No. 21030



Prod.-No. 21040