

LUCIFER®

EExPress™

*EEx p [ia] m IIC T5
Bus Manifold
for pneumatic
actuator control*

*Catalogue 8752/GB
June 2002*



Parker

Contents	Page
1. Product introduction	2
2. Applications	2
3. Product configuration	3
4. Product description and main features	4
5. Product operating principle	6
6. Typical installations comparison	7
7. Customer benefits	8
8. Functional Data	13
9. Mechanical Data	15
10. Electronic / Electrical Data	17
11. Gateway Interfacing	24
12. Bus Connection	26
13. Approvals	27
14. Storage	27
15. Identification	28
16. Quality	28
17. Warranty	28
18. Spare Parts Kit	28
19. Environment	28
20. Dimensions	29
21. How to Order	30



1. PRODUCT INTRODUCTION

The EExPress™ bus Manifold is a patented stackable system composed of :

- 1 x End plates Kit
- X x Solenoid valve module
- X x Input sensor module
- 1 x Gateway

The EExPress™ Explosion-proof manifold 5/2 valve island design uses the **EEx p [ia] m IIC T5 protection**.



Up to 32 valves per island require one bus address only.

The system includes a bus part satisfying the intrinsic safety requirements and communicating directly with a master control unit by using the Profibus DP protocol.

The manifold assembly and the dedicated power supply are coping with the “p” protection.

The valve coils are coping with the “m” protection.

2. APPLICATIONS

This smart EExPress™ bus manifold package has been designed for the control of pneumatic actuators in Process Industries with **hazardous environments Zone 1 or Zone 2** such as:

- Ghemical & Pharmaceutical.
- Gas and solvent handling
- Powder transportation.
- Refining.
- Etc.

These high demanding markets are concerned with:

- Process & people safety
- Plant installation simplification
- Process productivity
- Friendly use product
- Partners support



3. PRODUCT CONFIGURATION

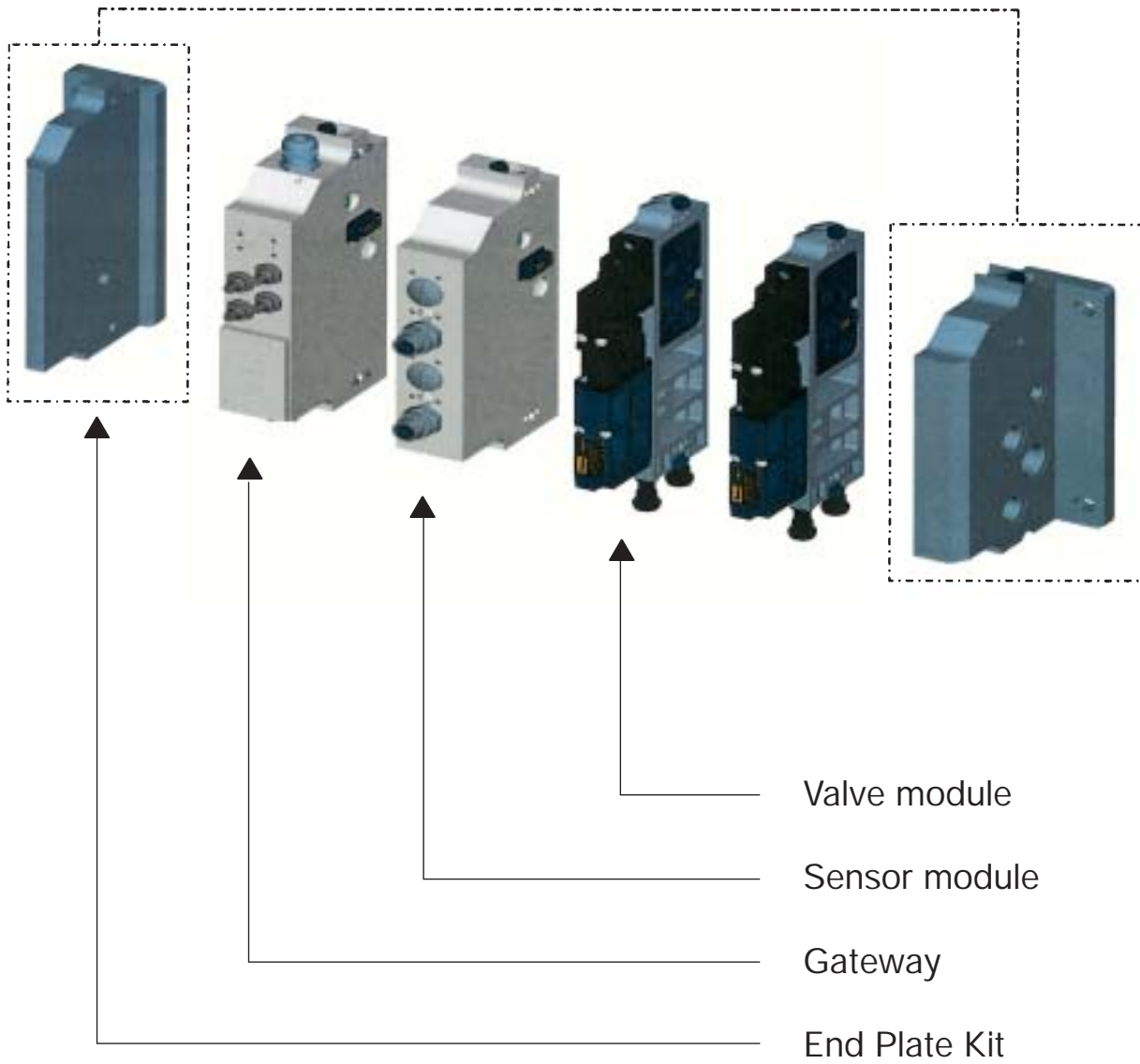

4. PRODUCT DESCRIPTION AND MAIN FEATURES

The Parker Lucifer EExPress™ Manifold is a stackable valve system with advanced specific features.

- The solenoid valves are pressurised with a working pressure up to 10 bar.
- The inlet pressure port and the exhaust ports are located on the "front pressure plate".
- The actuator ports are located on each solenoid valve module.
- A safety pressure of 50 mb pressurises the manifold.
This safety pressure prevents the manifold from any gas penetration – therefore all the electronic cards cannot be in contact with the environmental gas.
This corresponds to the LCIE approval for "EEx p" protection.
- A safety pressure sensor continuously measures the 50 mb safety pressure and the sensor signal is continuously monitored by the gateway.
If the safety pressure decreases below the set point of 20 mb, the gateway will then automatically deliver a flag error through the bus to the PC control unit.
- The integrated relief valve has two functions :
 1. To purge the safety pressure chamber (EEx "p") during the starting phase by putting an over pressure >500 mb.
 2. To secure the safety pressure at ≤ 300 mb.

N.B. This pressure is measured by the safety pressure sensor. When this pressure is >300 mb, a flag error will be automatically delivered through the bus by the gateway up to the PC control unit.

- The EExPress™ manifold is delivered with a shielded 2,5 m long cable to the gateway. This cable has :
 - 2 x wires for solenoid valve power supply
 - 2 x wires for gateway and input sensors uninterruptible power supply (UPS)
 - 1 x earth wire.

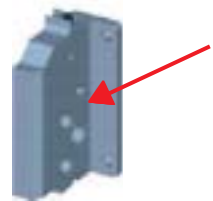

- The EExPress™ manifold uses the Profibus DP protocol and offers two possibilities of bus connections :

1. Optical fibre connection



2. Copper connection



- An **intrinsic safe circuit** allows to disconnect the copper communication from the gateway in Zone 1 or 2 without risk. This corresponds to the LCIE approval **for EEx [ia]** protection. N.B. **Optical fibre does not** require such protection.
- NAMUR type ON/OFF (NPN) sensor signal can be directly connected on the input sensor module.
- An intrinsic safe circuit allows to disconnect the sensor cable from the input sensor module in Zone 1 or 2 without risk. This corresponds to the second LCIE approval **EEx [ia]** protection.
- The solenoid valve coil is encapsulated in plastic material. This corresponds to the LCIE approval for **EEx m** protection.
- The coil connection to the EExPress™ manifold has a patented specific design. Under coil power "ON" condition, this specific design allows to disconnect the solenoid valve in Zone 1 or Zone 2 without risk.
- Possibility of programming parameters **on-site** such as:
 - setting flag errors limits for the supply voltage
 - setting flag errors limits for the watchdog communication
 - addressing the manifold at the start up phase
 - etc.



5. PRODUCT OPERATING PRINCIPLE

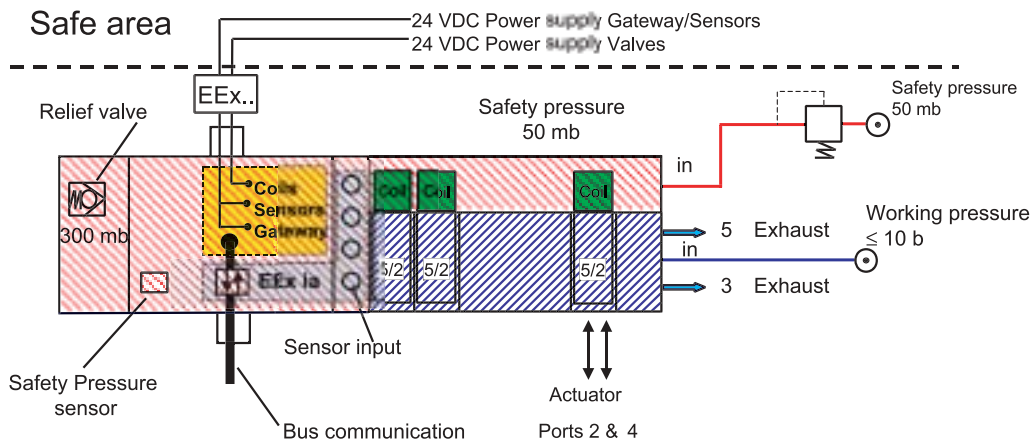

Hazardous area zone 1 or 2

- Gateway
- Intrinsically safe circuit = "ia" protection
- Solenoid valve coil = "m" protection
- ≤ 50 mb safety pressure area = "p" protection
- ≤ 10 b working pressure area

Power supply

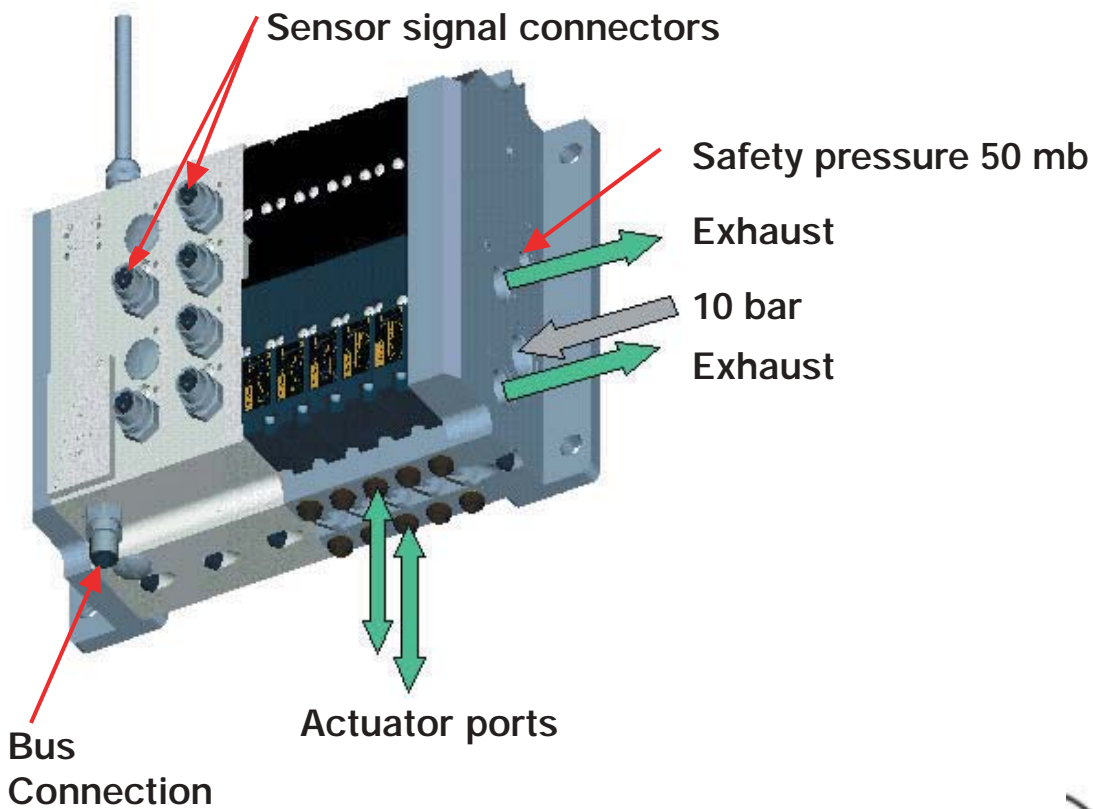

6. TYPICAL INSTALLATIONS COMPARISON

6.1 Typical Pressurised cabinet mounting installation

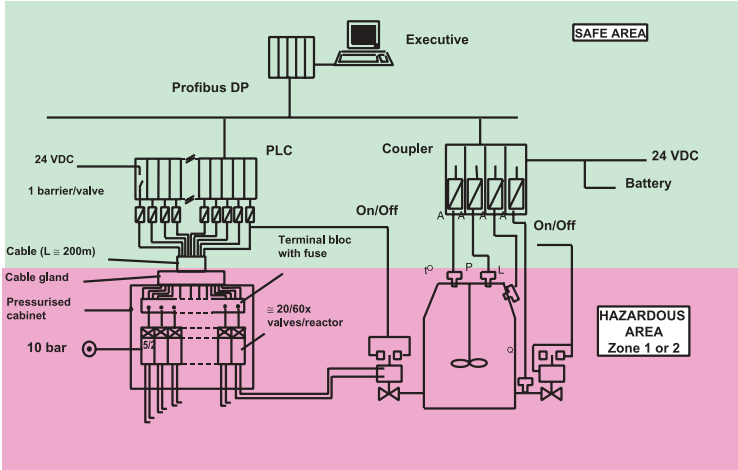

This solution implies the use of:

- PLC
- Safety barriers (1 x per valve)
- Long & heavy cabling to the EEx zone
- Pressurised cabinet
- Electrical connector bloc
- A lot of fittings
- Long and oversized piping
- A lot of man hours.

6.2 Typical low power solenoid valve installation

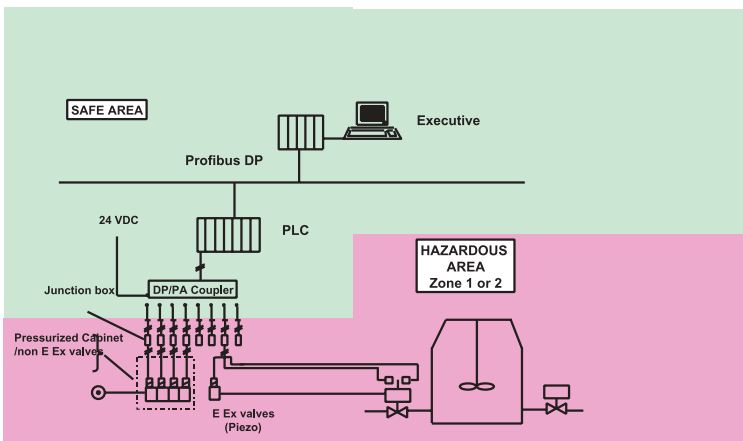

This solution implies the use of:

- PLC
- DP/PA coupler (1 x per ~ 6 valves)
- Junction box (1 x per valve)
- Long and heavy cabling to the EEx zone
- A lot of fittings
- Low speed communication given by Profibus PA
- Risk of communication loss due to cut cable for power and bus.

6.3 Typical Parker Lucifer EEx bus manifold mounting installation

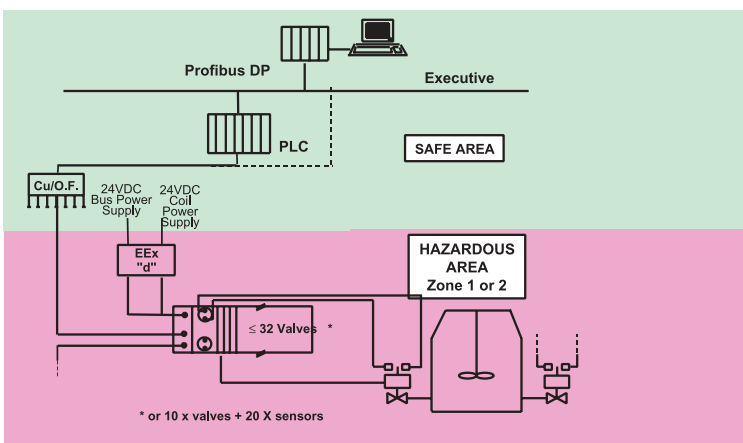

- A/ Better Process & People safety
- B/ Plant installation simplification
- C/ Increased Process productivity
- D/ Easy to use product

From:

E/ A qualified partner.

7. CUSTOMER BENEFITS FROM PRODUCT FEATURES

7.1 Better process & people safety :

- With separated wiring, the bus communication * is maintained "ON" even if the coil voltage supply is cut.
* Solenoid valve status + inputs sensor status + safety pressure status + etc.
- The robust design guarantees a better tightness than pressurised cabinets and thus a better EEx "p" protection.
- The diagnostic capabilities offer permanently a real reliable Process Control.
- **EEx p [ia] m IIC T5** protection as well as the patented coil connection eliminate risks associated with wrong handling.
e.g.: disconnection of bus or sensor connectors in presence of gases.
- It provides a better Process Control due to centralised mounting close to the pneumatic actuators.
- The 5/2 valves are designed with a "Fail safe" position. In case of coil voltage or inlet pressure failure, the internal valve air flow occurs according to a pre-determined flow pattern.
- In addition to the bus communication appropriate LED give the users in plant a visual information about the Process status.
- Authorised users in plant may re-address the manifolds directly on site.

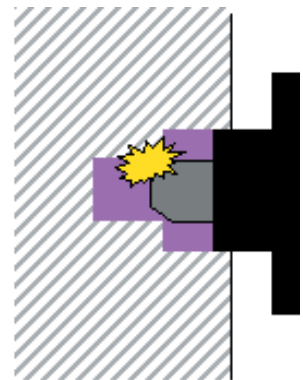

This patented design allows to disconnect the solenoid valve in zone 1 or 2 without risk

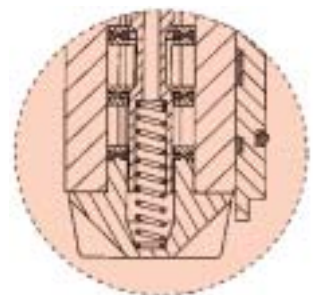

7.2. Plant installation simplification



... a child game !

- It significantly reduces the need of electronic components such as: couplers, repeaters, safety barriers, PLC, etc.
- It significantly reduces the needs of mechanical components such as: pressurised cabinet, pneumatic piping, electrical wiring, connectors, etc.
- Only one bus address can operate and control up to 32 x solenoid valves on one manifold, i.e. up to 1024 valves per PLC channel.
- Due to its small size, to its large diagnostic capability and to the solenoid valve high flow capacity, it is the logical solution for most of the EEx applications.



7.3 Increased Process Productivity

- Since a plant installation is simplified:
 - the Engineering cost is reduced
 - the component package cost is reduced
 - the man hours cost is reduced
 - the production start-up phase is quicker.
- Since the Process is better controlled, the production can be improved in quality and / or in quantity.
- Since the manifold replaces a lot of components, the stocking cost is reduced.
- Since the installation is simplified, the Process trouble shooting is easier and quicker.
- Since the installation is simplified, the maintenance cost is much lower.



7.4 Friendly use product

- It uses the well known Profibus DP protocol
- It has been designed to approach a **“Plug and Play”** usage.



- A detailed brochure “Installation, Operating & Maintenance Instructions” No. 495284 gives the user all necessary information. This brochure is delivered with each EExPress™ product.
- Its stackable concept allows an easy extension in number of solenoid valve and/or input sensors.
- Its in plant manifold addressability allows to quickly restart the production after a breakdown.
- At a glance at the LED the user knows immediately the current production process status.

7.5 Qualified supplier

- Since the Parker Lucifer EEx Profibus manifold replaces a lot of components, the number of suppliers is reduced and thus the overall plant implementation is faster.
- Less suppliers means less diluted responsibility and a faster response time in case of problem.
- Less suppliers leads towards partnership relation which in turn implies
 - privileged support
 - short reliable product delivery time
 - successful cooperation for further product evolution.
- Due to the world wide Parker Lucifer coverage, customer can everywhere rely on a professional support.



Reg. No. 10440



8. FUNCTIONAL DATA

8.1 Fluids

(*safety pressure
& main pressure*)

Air and neutral gases.
Quality: Instrumentation
Filtration: <25 μ
Humidity: <85%
Lubrication: non lubricated fluid.

8.2 Pressures

Operating pressure: Minimum: 2 bar (30 psig)
Maximum 10 bar (150 psig)

Safety pressure (providing the EEx p protection):
20 to 300 mbar, nominal value 50 mbar.

8.3 Pneumatic connection

Pressure plate with:

- G 1/2 ports for the main pressure (1)
- G 3/8 ports for the exhausts (3 and 5)
- G 1/8 ports for the safety pressure supply.

Valve sub-base with user ports (2 and 4).
The connection is made by means of fast couplings
(6/8 mm) tube.

8.4 Mounting position

Indifferent – with 4 x M8 screws at the end plates
for rail or wall mounting (carried out by the customer)

8.5 Solenoid valve

Function(s): 5/2 – 2 positions – monostable
Orifice sizes: Inlet diameter: 4 mm
Exhaust diameter: 4 mm

Flow: Qn = 400 NL/min

Pilot: internal pilot supply with captured exhaust.

Response time: <50 ms (90% of the pressure
according to CETOP), at 25 °C.

Life expectancy: >2 millions of cycles.

8.6 Temperatures

Fluid: Minimum -10 °C (15 °F)
Maximum +50 °C (122 °F)
Ambient: Minimum -10 °C (15 °F)
Maximum: +50 °C (122 °F)

- 8.7 Environment** Installation for the process industry (indoor and / or outdoor installations).
- 8.8 Sealing & Degree of protection** Main pressure:
Internal leakage per way [Ncm³/min]: 10 at 10 bar per single base / valve module.
External leakage [Ncm³/min]: 2 at 10 bar per single base / valve module.
- The admissible leakage of the complete manifold can be the multiple of the admissible leakage for the single valves
(e.g. manifold with 32 valves = 32 x 2 cm³/min = 64 cm³/min).
- Safety pressure:
Internal/external leakage [NL/h]: <4.8 at 50 [mbar] per manifold.
- 8.9 Degree of protection** IP 65 according to IEC 529 standard.
- 8.10 Corrosion** Withstands salt spray corrosion test: temperature 40 °C +/- 2 °C, 5% NaCl, during 100 hours, according to DIN 50027.
Withstands industrial atmosphere (SO₂ test according to DIN 50018).
Withstands humid heat during 48 hours at 50 °C ambient temperature with 95% relative humidity.
- 8.11 Vibration resistance** Meets the IEC 68-2-6 standard.
- 8.12 Shock resistance** Meets the IEC 68-2-27 standard.
- 8.13 Marking** Solenoid valve: Product type, Manufacturing date and Index of major modification, ISO diagram.
- Gateway: Part number + Manufacturing date.
- Manifold itself: EM No., approval number and related pictographs (Ex, CE marks, etc.).

9. MECHANICAL DATA

9.1 Solenoid valve

The valve is a spool design with spring return. This feature allows a failsafe function: In case of power/pressure failure the spool returns automatically to its predetermined preferential position.

The pilot stage is a 3/2 valve with a manual override control.

9.2 Solenoid valve sub-base

The electrical connection between the coil and its sub-base is made in such a way that the **EEx p** conditions are met.

9.3 Valve module



The combination of a sub-base and a solenoid valve is called module. The valve is fixed on the sub-base with two stainless steel screws while, at the same time, the coil of the valve is connected to the electronic part of the base.

9.4 Sensor module



In addition to the valve, the manifold may contain another kind of module, which has 2 or 4 connectors for powering the ON / OFF sensors and collecting their output signals.

These connections meet the **EEx [ia]** requirements.

9.5 End plates



1/ The pneumatic connection plate serves as a cover for the valve modules and allows to connect the main pressure and the safety pressure (for **EEx p** protection) to the manifold. It contains a relief valve adjusted to 300 mbar, which can be used for purging the safety pressure chamber (**EEx p**) during the starting phase. The plate also serves as a support for the complete manifold fixation.

2/ The closing plate serves as a cover for the gateway and ensures the tightness of the manifold.

The plate also serves as a support for the complete manifold fixation.



9.6 Materials

Valve: Plastic, PA 6 glass fibres reinforced

Pilot: Plastic, polyester

Base: Cast aluminium, treated against corrosion and porosity

Gateway: Machined aluminium, treated against corrosion

End plates: Machined aluminium, treated against corrosion

Sealing: NBR.

Screws: Stainless steel

9.7 Weight

Complete manifold with 32 valves: Approx. 15 kg

Approximate weight per element:

Weight of single module with base, electronics and valve: 0.4 kg

Weight of pressure-port plate: 0.6 kg

Weight of supply module, gateway: 0.5 kg

Weight of closing plate: 0.6 kg.



10. ELECTRONIC & ELECTRICAL DATA

10.1 Electronic parts description

The electronic parts control an arrangement of valves modules and / or sensors modules. This arrangement communicates with an external fieldbus and allows to open or close valves, to read out the state of the sensors and to transmit appropriate diagnostics. For each manifold, the maximum number of addressable elements (valves and / or sensors) is 32. A library function is integrated in the manifold.

10.2 Electrical voltage supply

The voltage supply is made via a shielded cable (# 2.5 m) delivered mounted on the manifold and fixed by means of an IP 68 cable gland EEx e...

This cable gland integrates a strain relief design.

The user must connect this cable to an EEx .. approved box close to the manifold.

This cable is composed of 5 leads with a cross section $> 0.34 \text{ mm}^2$ (AWG 22).

For process-safety reasons, 2 separated power supplies are provided:

- A general power supply for the coils 24 VDC $\pm 15\%$ (max. 4 A)
- An uninterruptable power supply (UPS) 24 VDC $\pm 15\%$ for gateway and logical circuit.

The 5th lead is for earth connection.

Both "0 volt" are interconnected within the manifold.

N.B. For circuit simplification both power supplies can be connected together.

10.3 Electronic elements

The electronic part of the manifold contains 3 types of elements:

1. Gateway
2. Valve module
3. Sensor module

10.3.1 Gateway

10.3.1.1 Function

The gateway ensures the connection between the Profibus DP fieldbus and an internal bus.

Depending on the transmitted and received messages, it allows:

- to read the diagnostics (flag errors)
- to read the state of the sensors
- to change the state of the coils (ON/OFF).

10.3.1.2 Description

The gateway comprises:

1/ A P.N.O certified electronic card corresponding to the selected bus protocol: Profibus DP.

2/ A card with a micro-controller, containing the firmware control for:

- the internal bus
- the diagnostics
- the communication with the Profibus card.

3/ Either a bus copper link communication or a standardised interface for ($\lambda = 850 \text{ nm}$) optical fibre.

10.3.1.3 Power consumption

The micro-controller card and the Profibus card consumption is approximately 2 watts (400 mA under 5 V).

10.3.1.4 LED signal status (External bus)

2 LED (**yellow, green**) are available for indicating the state or the operation of the external bus according to the Profibus standard protocol.



FUNCTION	READY (yellow)	RUN (green)
No supply	OFF	OFF
No PROFIBUS communication	ON	Flashing
Correct PROFIBUS communication	ON	ON

- 2 additional LED (red and green) reflect the different internal states of the manifold.

LED	Red	Green
OFF	No error	No supply voltage
Flashing	Flag error presence	
ON	Firmware problem	Power supply = OK

10.3.1.5 Solenoid valve control

4 bytes (32 bits) correspond to the output state of the solenoid valves.

Bit = "1" corresponds to valve "ON".

Bit = "0" corresponds to valve "OFF".

N.B. At the initial state all bits are at "0".

The registers are written from the LSB (bit 0) to the MSB (bit31).

The state of the first valve mounted next to the gateway corresponds to the value of bit 0 and so forth. For a manifold with only 7 valves, bit 8 and the 3 further bytes are not to be considered.

Another register of 4 bytes (programmable) corresponds to the default values of the valves. (Valve_Default_Status_register).

This register overwrites the valve control register in case of:

- 1 – Loss of safety pressure.
- 2 – Loss of communication between the gateway and the master during at least four (4) seconds.
- 3 – The UPS voltage drops below 18 V.

10.3.1.6 Diagnostics

Flag errors are coded in binary form in a register of 4 bytes corresponding to 32 bits. The system can thus scroll down up to 32 diagnostics to the master. The list below corresponds to the error causes identified and implemented until now.

The flags indicate an error and the Master can read the source of the error and identify the faulty element(s).

flag_error_configuration:

Soon after power ON, the system analyses its configuration. An error is signalled, if the system detects no module.

flag_error_module:

During operation, the system monitors the electric value of the modules.
An error appears if a communication problem occurs between the gateway and a module (sensors or solenoid valve).

flag_error_coil:

During operation, the system monitors the electric state of the coils.
An error is signalled, if a difference between the control signal (ON/OFF) and the electric state of the coil appears.

flag_error_high_voltage:	<p>During operation, the system monitors the supply voltage of the coils. An error is signalled if the voltage is greater than 27.6 V.</p>
flag_error_low_voltage:	<p>During operation, the system monitors the supply voltage of the coils. An error is signalled if the voltage is lower than 20.4 V.</p>
flag_error_no_voltage:	<p>During operation, the system monitors the availability of the 24 VDC coils voltage supply. An error is signalled in absence of supply voltage.</p>
flag_error_high_psi:	<p>During operation, the system monitors the Safety Pressure value. An error is signalled if the Safety Pressure exceeds the (adjustable) threshold of 300 mbar.</p>
flag_error_low_psi:	<p>During operation, the system monitors the Safety Pressure value. An error is signalled if the Safety Pressure drops below 20 mbar. This is a major alarm. The E Ex p protection is no longer ensured. Solenoid valves will be put in a predetermined ON or OFF position according to the pre-programmed "Valves_Default_Status".</p>
flag_error_watchdog:	<p>Any communication on the bus causes a re-start of the watchdog. If the bus does not respond during more than 4 seconds (programmable parameter), then solenoid valves will be put in a predetermined ON or OFF position according to the pre-programmed "Valves_Default_Status".</p>
flag_error_lost_Progr._Counter:	<p>The system has its own internal watchdog. If the programme disappears a reset occurs after 65 ms, without deleting the RAM.</p>
flag_error_UPS:	<p>During operation, the gateway UPS voltage supply is monitored. If this voltage drops below 18 V, all parameters are automatically stored in the EEPROM and solenoid valves will be put in a predetermined ON or OFF position according to the pre-programmed "Valve_Default_Status". As soon as the voltage reaches a value greater than 18 V, then automatically the valves will be</p>

put back to their previous state before the voltage dropping.

flag_error_checksum:

Each time the manifold is powered ON, the system reads the instructions in the programme and checks their checksum.

The absence of this flag is the guarantee of the programme integrity.

10.3.1.7 Firmware specialities:

- Automatic configuration at each power ON:
The gateway automatically recognises the position and the number of modules (sensor + valve) being part of the manifold.
The configuration is then saved in a register.
- Every solenoid valve and / or sensor cycle is registered in a counter. The counter content is stored in a EEPROM approximately every 24 hours.
This feature allows an individual component preventive maintenance.
- Other specialities:
See "Installation, Operating & Maintenance Instructions" brochure No. 495284.



10.3.2 Valve Module

10.3.2.1 Function

The electronic parts of the module interfaces the solenoid valves to an internal bus.

10.3.2.2 Electronic description

The card contains:
 1/ The address-decoding part of the internal bus.
 2/ The driver part (attraction, holding), short circuit protected by means of a resettable fuse.
 3/ A current (I) measurement of each coil.

10.3.2.3 LED indicator



A red LED integrated in the base corresponds to the state of the coil:
 LED OFF = coil without voltage.
 LED flashing = defective coil or no current or incorrect current.
 LED ON = correct coil energising.

10.3.2.4 Coil power

At a nominal voltage of 24 VDC,
 current peak at attraction = 50 mA during 20 ms (1.25 W), holding = 20 mA (0.5 W).

10.3.2.5 Coil protection

EMC protection with diode in parallel to the coil.
 100% energisation generates a surface temperature rise $\Delta t^\circ < 20^\circ\text{C}$.

10.3.2.6 Coil data

Nominal current (1) [mA]		Resistance [Ohm] at 20°C	Duty cycle [%]	Temperature [Δ°C]
Attract	Holding			DC
50	20	480 ±7%	ED 100%	≤ 20

(1) Nominal current at U_{nominal} + cold coil

10.3.3 Sensor Module

10.3.3.1 Function

The electronic parts of the sensor module interfaces Intrinsically Safe (NAMUR type) ON / OFF sensors output to the internal bus.

10.3.3.2 Electronic description

The card contains the address-decoding part of the internal bus, the safety power-supply part, the signal detection part for the 4 single sensors or 2 double sensors.

10.3.3.3 LED indicators

The red LED integrated in the base correspond to the state of each sensor.

- 10.3.3.4 Connection** The ON/OFF sensors connectors are M12 with female pins.
- 3 pins for 2 wire ON/OFF sensors
 - 4 pins for 4 wire ON/OFF sensors



Connector for sensors
with 2 wires

1 (Not used)
2 Power
3 Signal
4 (0 volt)



Connector for sensors
with 4 wires

1 Signal
2 Signal
3 Power
4 Power

10.3.3.5 Power output and protection

The module makes available, at each connector, a 12 VDC supply voltage protected by a current limiter, thus corresponding to an associated intrinsically safe device. The calculation of the safety loop (source, cable and sensor) is the customer's task and depends on the parameters (L, C, R and U_{max}).

10.3.3.6 State of the sensors

4 bytes (32 bits) correspond to the output state of the sensor.
Bit = "1" corresponds to sensor "ON".
Bit = "0" corresponds to sensor "OFF".

10.3.3.7 Recommendation

For severe environment conditions where the emitted EMC interferences have to be reduced, shielded cable connections have to be used for the sensors.



11. PROFIBUS GATEWAY INTERFACING

Common:

The controller (uP), on the gateway, manages communications between an internal bus and the external fieldbus Profibus DP. This protocol is supported by a Siemens ASIC SPC3 driven by an other microprocessor on a specific board (COM-DPS from Hilscher GmbH). The physical support of the “1” level of the ISO schema communication is:

- Either a copper link (RS485) connected through an EEx [ia] interface and sourced by a safety barrier (typical @Stahl 9373/21-12-10).

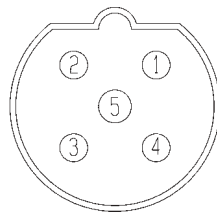

- 1 Supply. +5vcc
- 2 Signal A+
- 3 Supply. 0 volt
- 4 Signal B-
- 5 Shield

M12 Connector for Profibus

Shield connected via the body to the earth

- Or an optical fibre link with integrated repeater function, sourced by a copper/optical coupler (typical @Siemens SINEC L2FO ...).

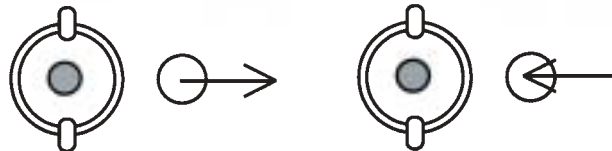

Emitter

Receiver

FMT Connector

Optical Fiber $\lambda = 850 \text{ nm}$

Frequency :

In any case, due to use of opto-coupler and/or safety barrier, the maximal baud rate is 1.5 MHz.

Address change:

The delivery address is 39 (highest).

At power up, the set of address is made by reading the positions of 2 decimal encoders.

It's possible without switching off the power to change the positions and push on the reset button (under the cover). This operation can only be made in a safe area during a start-up phase or an emergency stop.

Hardware:

A memory space, Dual Port Ram Memory is the key of the data flow between the ASIC and the controller.

The locations of memory are in conformance with the software ASIC's configuration.

2 registers are well dedicated to this handshake.

Bus configuration:

- With copper link, the manifold could be connected to the bus by a Té (trunk) from the main line or could be used itself as a repeater to have a serial link (second connector allowed).
- With optical link, the 2 configurations are possible (star or trunk).

Remark:

The Profibus DP configuration of the manifold is available on the file HIL_7501.GSD accessible as follows:

www.profibus.com

choose "Librairies"

then "**Hilscher Gesellschaft für Systemautomation mbH**",

open under "Device Type": "**General**"

then under "Device": "**COM-DPS**"

See "Installation, Operating & Maintenance Instructions"

No. 495284



12. BUS CONNECTION

12.1 Copper connection:

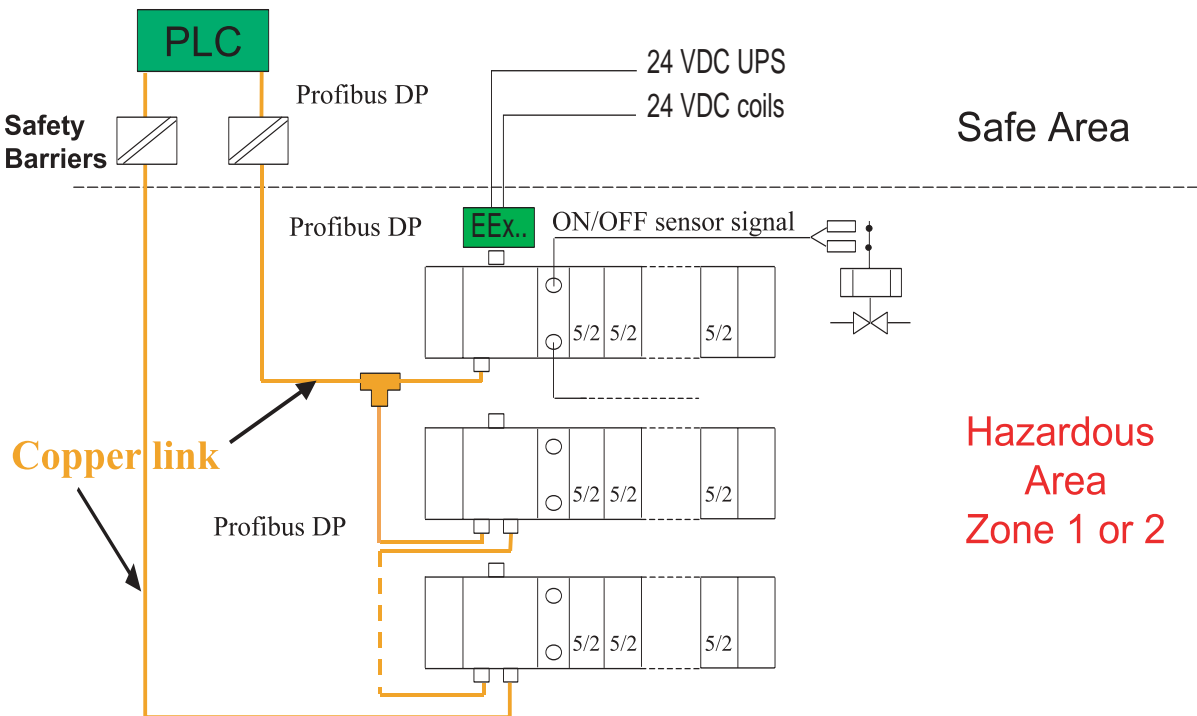

12.2 Optical fibre connection:

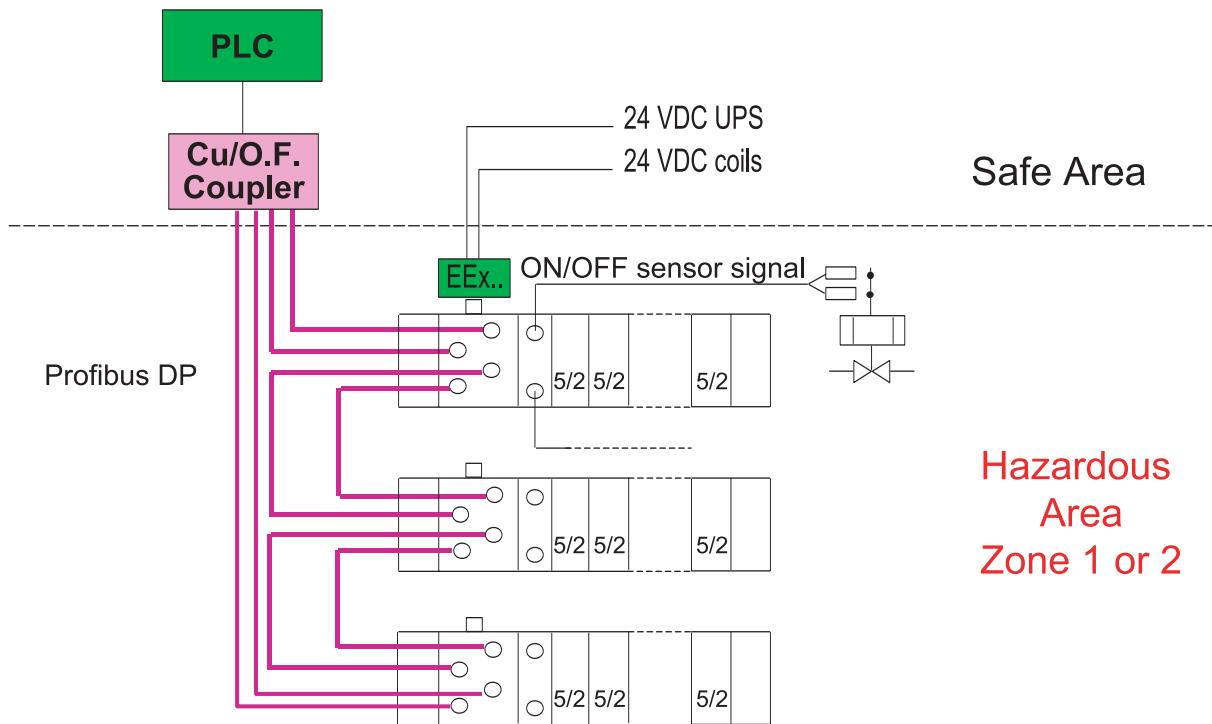

13. APPROVALS

The signal conditioning and power supply circuits leading to the sensor connectors are approved to **EEx ia**. The injection moulded plastic of the coils of the pilots is approved to **EEx m**.

The entity of the **EEx p [ia] m IIC T5** approvals allows the use of the manifold in **hazardous zone 1 or 2**.

The complete mechanical and electrical device is sealed to IP 65.

**Certification: LCIE 01 ATEX 6013 X
ATEX EN 50014-016-020-028**

13.1 Safety pressure conditions

nominal:	50 mbar	(0.7 psig)
maximum:	300 mbar	(4.35 psig)
minimum:	20 mbar	(0.3 psig)

13.2 EMC standards

The manifold meets the following EMC standards regarding electromagnetic interferences.

- Immunity: EN 6100.4.2 to 4.6.
- Emission: CISPR16

The complete manifold must be connected to earth.

14. STORAGE

Storage temperature

Minimum	-30 °C	(-22 °F)
Maximum	+85 °C	(185 °F)

15. IDENTIFICATION SOFTWARE

With regard to the electronics, by recording the parameters (Manufacturer, Serial number, Manufacturing date, Firmware-version, Modification index). These parameters are written into the EEPROM when powering up for the first time, in the factory.

16. QUALITY

MTBF of electronics >18000 hours (2 years)
Reliability function for 1000 hours: 0.95

17. WARRANTY

1 year / Manufacturing date.

18. SPARE PARTS KIT

1. Valve module (base, electronics, gasket, valve, screws) ref. 494237.01
2. Valve only (with mounting screws) ref. 495340.01
3. Sensor module ref. 495141.01 (2 sensors) or ref. 495142.01 (4 sensors)
4. Gateway ref. 495176.01 – Cooper (1 connector)
ref. 495275.01 – Cooper (1 connector + repeater)
ref. 493972.01 – Optical fibre

19. ENVIRONMENT

EExPress™ is manufactured in accordance to the environmental Parker Lucifer policy according to ISO 14001.

20. INSTALLATION, OPERATING & MAINTENANCE INSTRUCTIONS

See brochure 495284.



20. DIMENSIONS

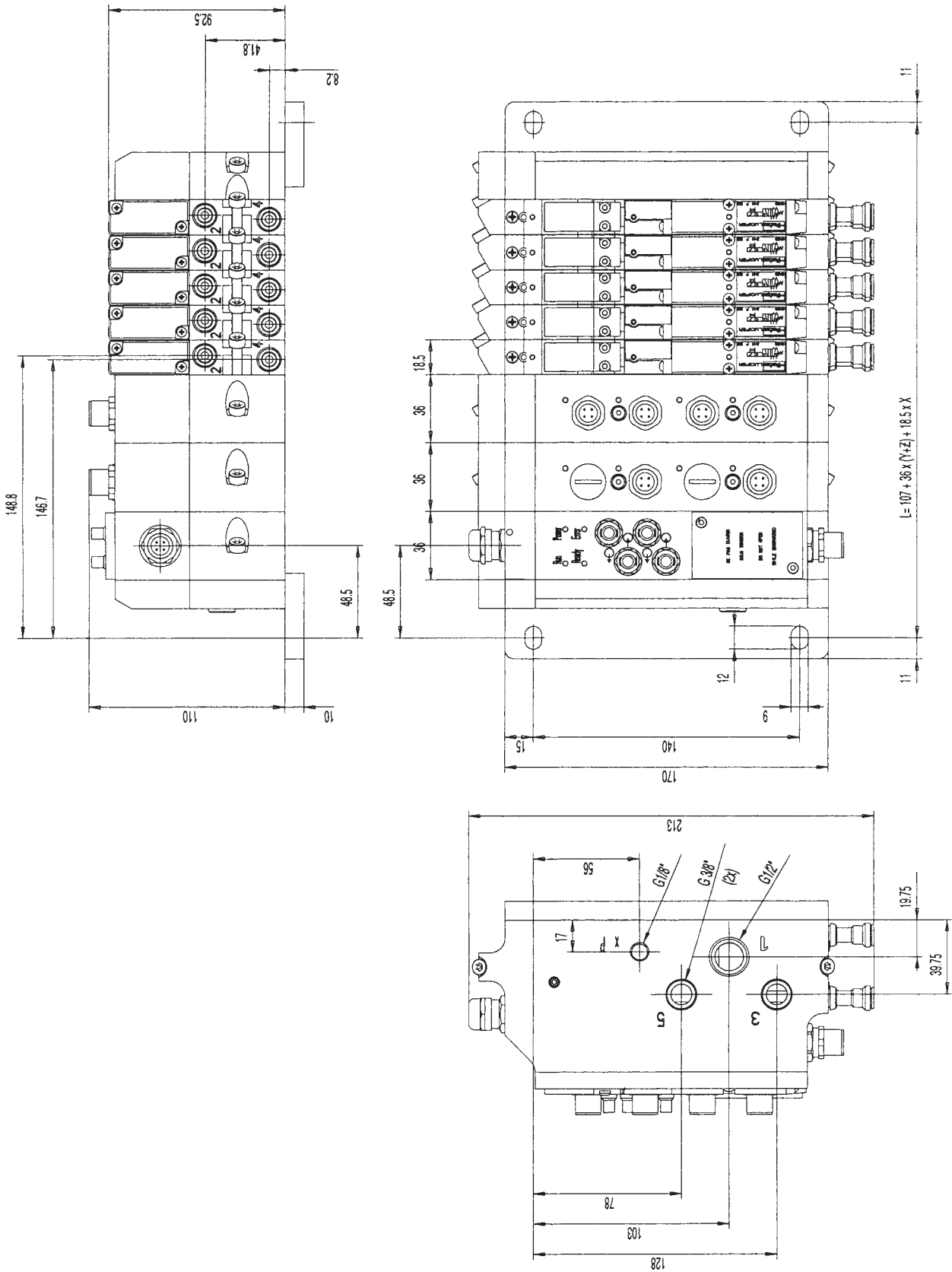

21. HOW TO ORDER

21.1 Components to order

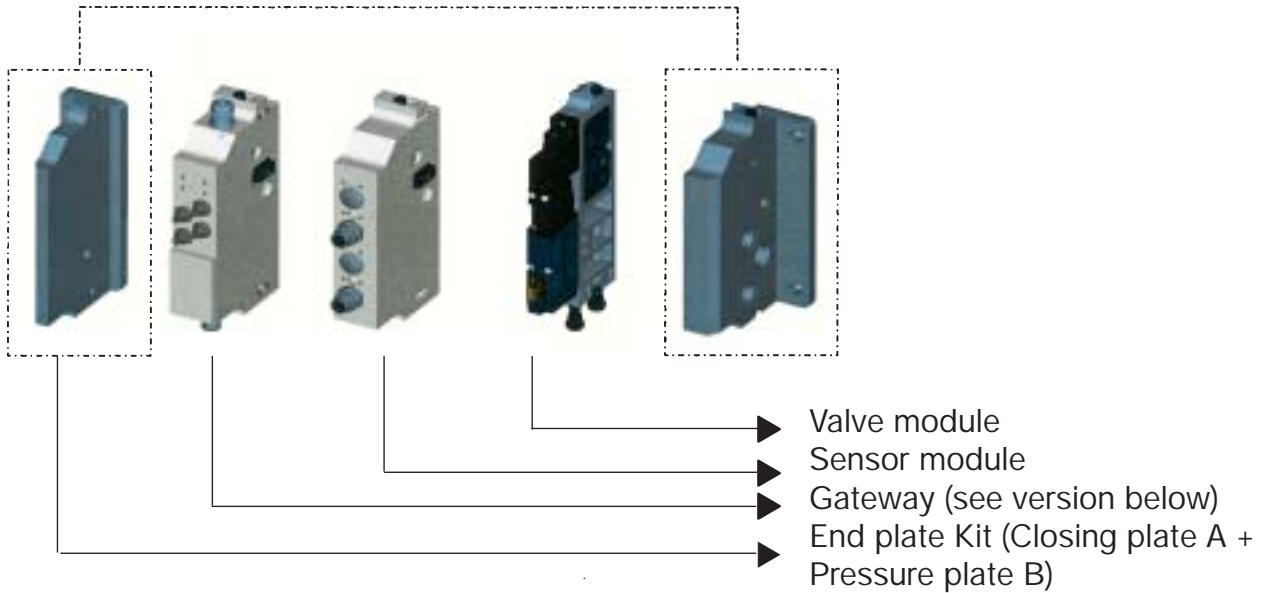

Gateway versions



Copper wire version –
1 connector



Copper wire versions –
 • 1 connector
 or
 • 1 connector +
 1 repeater



Optical fiber version
(with repeater only)

HOW TO ORDER **ASSEMBLED MANIFOLDS**

21.2 Choose the components for 1 manifold in the following order:

1 - End plate kit			
N.B. One plate kit only per manifold			
<i>End plate A</i>	<i>Pressure supply plate B</i>	<i>Order No.</i>	<i>Qty</i>
BSP	BSP	495190	1
2 - Gateway selection			
N.B. One gateway only per manifold			
<i>Protocol</i>	<i>Communication link</i>	<i>Order No.</i>	<i>Qty</i>
Profibus DP	Copper (1 connector)	495176	1
Profibus DP	Copper (1 connectors + 1 repeater)	495275	1
Profibus DP	Optical fibre	493972	1
3 - Sensor modules			
N.B. 0 up to 8 sensor modules per manifold			
<i>Nb of connectors</i>	<i>Connection</i>	<i>ON/OFF</i>	<i>Order No.</i>
2x IN connectors	M 12	x	495141
4x IN connectors	M 12	x	495142
4 - Valve modules		<i>Order No.</i>	<i>Qty*</i>
N.B. 0 up to 32 valve modules per manifold			
Module with 5/2 valves		494237	0 to 32

* **Warning:** For one bus address, the combination sensor module + valve module has to fit the following formula: $4 \times (\text{Number of sensor modules with } 2 \times \text{IN connectors} + \text{Number of sensor modules with } 4 \times \text{IN connectors}) + \text{Number of valve modules} < 32$.

21.3 Example of manifold configuration and order:

Description	Order No. chosen	Qty per Manifold chosen
End plate Kit	495190	1
Gateway	495176	1
Sensor module – 2 IN connectors	495141	4
Sensor module – 4 IN connectors	–	–
Valve module	494237	8

Order: 5 manifold with above mentioned components.

The selected components will be supplied as an assembled manifold.

A – The label on the manifold shows:

1. The LCIE conformity for the EEx p [ia] m IIC T5 protection.
2. The LCIE approval code: EM followed by a manufacturing code. I.e. **EM 123456**

B – Each manufacturing code defines a specific manifold configuration

C – The **EM XXXXXX** is also mentioned on the shipping bulletin and on the invoice

D – To simplify, customers can re-order the same manifold by using the **EM XXXXXX** code mentioned on these documents.

22. HOW TO ORDER **SPARE PARTS**

22.1 Choose the components in the following tables:

1 - Plate kit				
N.B. One plate kit only per manifold				
<i>End plate A</i>	<i>Pressure supply plate B</i>	<i>Order No.</i>	<i>Qty</i>	
BSP	BSP	495190.01	specify	
2 - Gateway selection				
N.B. One gateway only per manifold				
<i>Protocol</i>	<i>Communication link</i>	<i>Order No.</i>	<i>Qty</i>	
Profibus DP	Copper (1 connector)	495176.01	specify	
Profibus DP	Copper (1 connectors + 1 repeater)	495275.01	specify	
Profibus DP	Optical fibre	493972.01	specify	
3 - Sensor modules				
N.B. 0 up to 8 sensor modules per manifold				
<i>Nb of connectors</i>	<i>Connection</i>	<i>ON/OFF</i>	<i>Order No.</i>	<i>Qty</i>
2x IN connectors	M 12	x	495141.01	specify
4x IN connectors	M 12	x	495142.01	specify
4 - Valve modules			<i>Order No.</i>	<i>Qty</i>
N.B. 0 up to 32 valve modules per manifold				
Module with 5/2 valves			494237.01	specify
5 - Solenoid Valves			<i>Order No.</i>	<i>Qty</i>
Solenoid valves 341 F 52 (without module)			495340.01	specify

N.B. – The suffix .01 after the part number indicates that the selected components will be supplied as stand alone spare parts.

- The Parker Lucifer responsibility is limited to each component individually.
- The final responsibility concerning the manifold operation will have to be taken by the installer.