

McDonnell-Miller Controls & Repair Parts

Section B

McDonnell-Miller Boiler Controls and Flow Switches including: Low water cut-offs, pump controls, liquid level controls, air and liquid flow switches and more!

Boiler Controls & Repair Parts	Page
Model 21 & 221	2
Model 25-A	3
Model 42, 42-A and 42S, 42S-A	4
Model 47 and 47-2	5
Models 51, 51-2, 51-S & 51-S-2	6-7
Model 53 & 53-2	8
Model 61	9
Model 63	10
Model 64	11
Model 67	12
Model 69	13
Model 70	14
Model 93 & 193	15, 16
Model 94 & 194	15, 16
Model 101A	17
Model 150, 150S, 157 & 157S	18, 19
Model 150E and 157E	20-22
Model 247 & 247-2	24
Model 551-S	23
Model 750, 750B and Remote Sensors	25-27
Model 764	33
Model 767	34
Model 847	35
Model 851 & 851-S	36
Model PS-851 & PS-852	30
Model PS-801 & PS-802	29
Model RB-24, RB-120 & RB-122	31
Model WF	32

Valves	Page
TC-4, Test-N-Check Valves	48
Flow Switches & Repair Parts	
AF Series	43
FS1 Series	40
FS4 Series	37, 38
FS5 Series	39
FS6 Series	41
FS7 Series	42
FS8 Series	39
T Series Timers	38, 39
Liquid Level Controls	
Model 18 & 18S — <u>Obsolete</u>	—
Model 27W	44
Model 65 & 165 — <u>Obsolete</u>	45
Model 80 — <u>Obsolete</u> — Parts not available	—
Model 518 — <u>Obsolete</u> — Parts not available	—
Model 3155	46
Model E-8 — <u>Obsolete</u> — Parts not available	—
Model LPC-2000 (replaced by Model 750)	28
Model PCH & PCL — <u>Obsolete</u> , see Model 750	25
Model PFC	47
RS Sensors	26, 28
Model VFS — <u>Obsolete</u> — Parts not available	—
Product Date Code Guide	48

Get more product specifications, more repair parts information, more stuff!

Secure Ordering On-Line
www.statesupply.com

McDonnell-Miller 21 and 221 Water Feeders

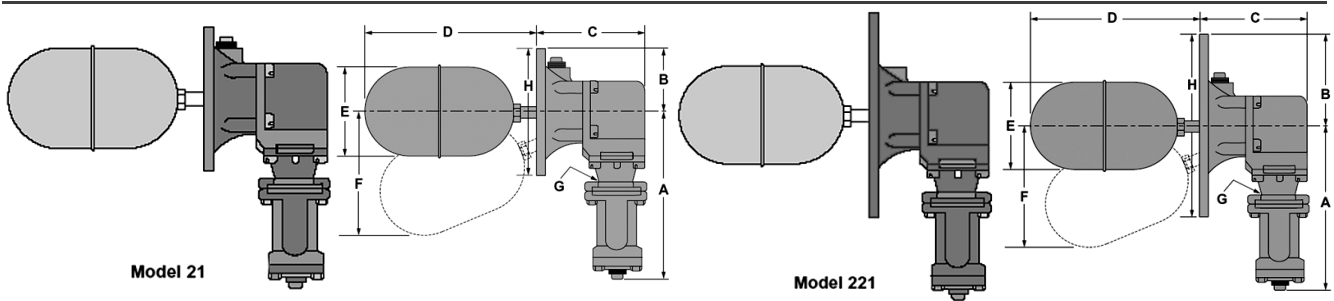

21 and 221 Water Feeder Features:

- The only difference between the Model 21 and the model 221 is the diameter of the mounting flange that connects to the tank: The Model 21 is 5-3/4"; the Model 221 is 8-1/2".
- Both the 21 and the 221 mount directly to the receiver tank — Eliminating the need for piping in equalizing connections.
- The water connection piping size on both models is 3/4" npt. The valve's soft-seat provides a long-lasting positive seal.
- The maximum water supply pressure is 150 psi. However, the maximum operating pressure is 35 psig.

Dimensions for Model 21							
A	B	C	D	E	F	G	H
8-1/2	3-5/16	5-5/8	8-13/16	4-3/4	6-1/4	3/4	5-3/4

Dimensions for Model 221							
A	B	C	D	E	F	G	H
8-1/2	4-11/16	5-5/8	8-13/16	4-3/4	6-1/4	3/4	5-3/4

Complete Models 21 and 221		
Model No.	Description	Order No.
21	Make-up water feeder; 5-3/4" flange diameter	MH1010
221	Make-up water feeder; 8-1/2" flange diameter	MH1107

Capacity Curve for Models 21 and 221

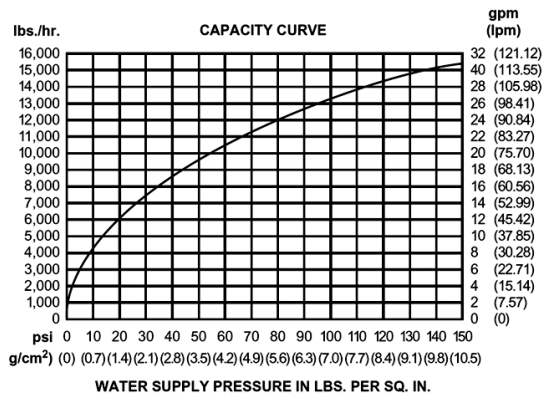

Repair Part Diagram for Models 21 and 221

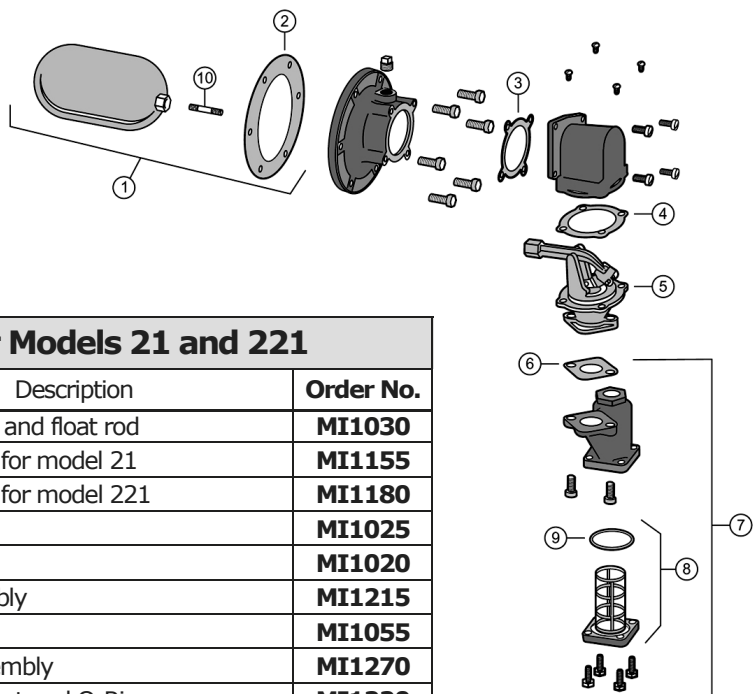

Repair Parts for Models 21 and 221		
Item No.	Description	Order No.
1	Float, gasket and float rod	MI1030
2	Head gasket for model 21	MI1155
2	Head gasket for model 221	MI1180
3	Gasket	MI1025
4	Gasket	MI1020
5	Valve assembly	MI1215
6	Gasket	MI1055
7	Strainer assembly	MI1270
8	Strainer basket and O-Ring	MI1220
9	O-Ring	MI1385

All McDonnell-Miller products shown are normally **in-stock and ready for same-day shipping.**

McDonnell-Miller 25A Water Feeder

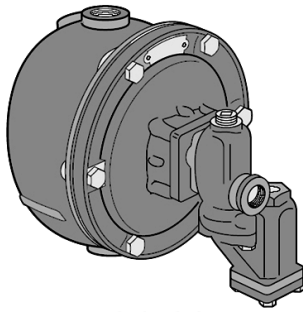

Series 25A

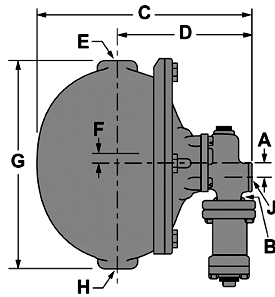

Features of the Model 25A

- Dependable float-operated feeder used to add water to condensate receiving tanks, capable of feeding 12½ gallons of water per minute at 35 psi of water pressure.
- Includes an integral, built-in replaceable strainer. Please replace the strainer every year.
- The maximum water supply pressure is 100 psi. Maximum tank pressure is 35 psig. Maximum water temp., 120° F
- Mounted to the condensate receiver tank with 1" pipe size top and bottom equalizing lines. Feeds water through a separate pipe permitting anti-siphon air gap.
- If you already have the 25A installed, and it's simply time for a replacement, just order the 25A head assembly: simply re-use the existing piped-in bowl, remove the old head assembly, put on the new one — You're done!

Replacement 25A Head Assembly

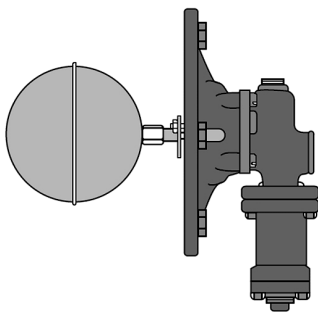

Already have a 25A water feeder installed? Need to replace it?

Don't put in an entire new unit! Simply order a new **head assembly**.

It's easier to install than a complete new unit, and for all functional purposes you make your old unit just like new. Your old bowl (already connected to the equalizing pipes) is most likely in good shape.

Model 25-A-HD

25A Head Assembly

Description	Order No.
25A Head Assembly	MI1040

So save some time and money — Order a new head assembly.

Dimensions of 25A (inches)

A	B pipe	C	D	E pipe	F	G	H pipe	J pipe
13/16	3/4	12¼	8⅞	1	1/2	10¾	1	3/4

Model 25A capacity: pounds/hour @ water pressure shown

10psi	20psi	30psi	40psi	50psi	60psi	70psi	80psi	100psi
3,100	4,500	5,600	6,550	7,400	8,150	8,800	9,400	10,200

Complete Model 25A

Model No.	Description	Order No.
25A	Make-up water feeder	MH1015

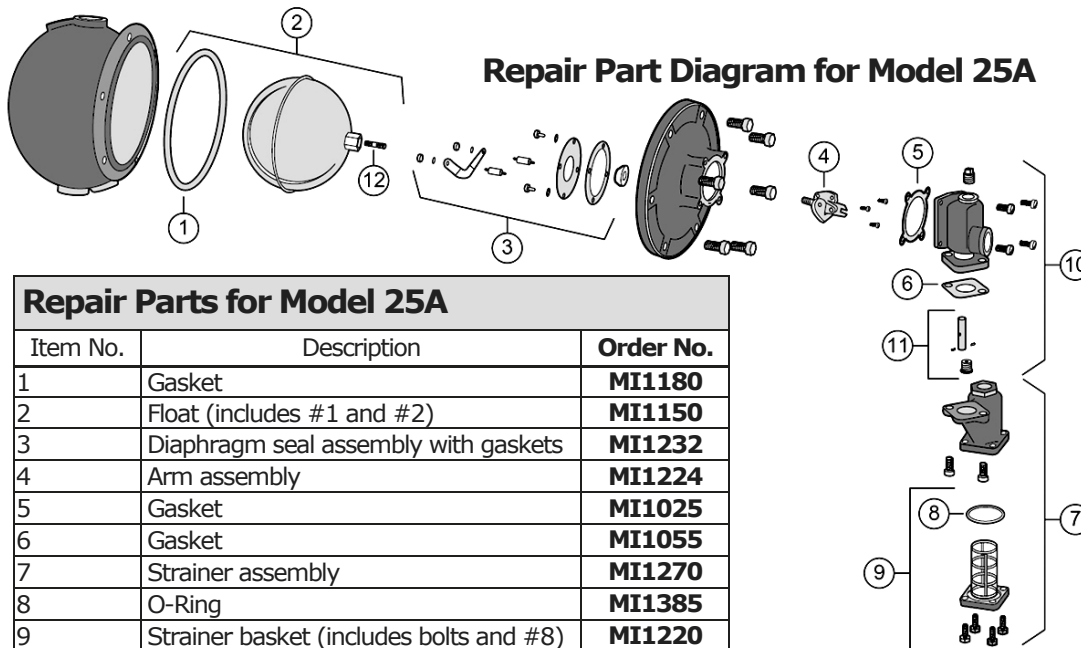

Repair Parts for Model 25A

Item No.	Description	Order No.
1	Gasket	MI1180
2	Float (includes #1 and #2)	MI1150
3	Diaphragm seal assembly with gaskets	MI1232
4	Arm assembly	MI1224
5	Gasket	MI1025
6	Gasket	MI1055
7	Strainer assembly	MI1270
8	O-Ring	MI1385
9	Strainer basket (includes bolts and #8)	MI1220
10	Valve assembly	MI1225
11	Stem & disc assembly	MI1230
12	Float rod	MI1041
Head Assembly for 25A		MI1040

McDonnell-Miller 42 Cut-Off & Pump Controller

No. 42 and 42S

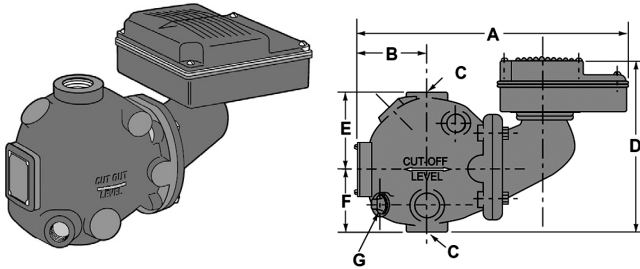

A	B	C pipe	D	E	F	G pipe
12-1/4	2-9/16	1	8-7/8	3-11/16	3-1/8	1/2

No. 42-A and 42A-S

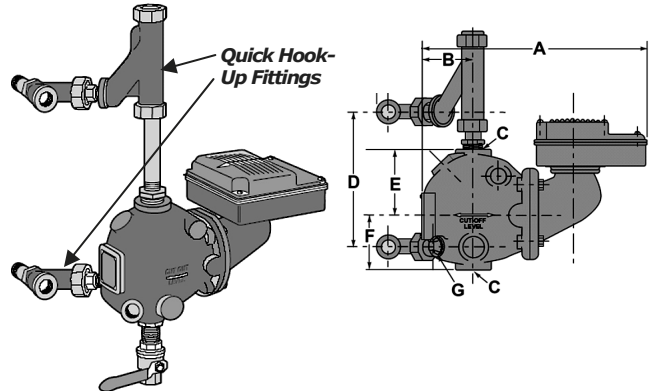

A	B	C pipe	D	E	F	G pipe	
12-1/4	2-9/16	1	7-1/4	16-11/16	2-3/4	3-1/8	1/2

Features of the Model 42, 42A, 42S & 42A-S

■ All models are float-operated pump controllers and low-water cut-offs with either SPST mercury switches (42 and 42-A) or non-mercury "snap switches" (42S and 42-AS) operating at different levels to control the boiler feed pump and cut-off the electrical current to the boiler in the event of a low-water condition. Maximum operating pressure: 50 psi.

■ The Snap-Switch models replaced the "hazardous material" Mercury models — discontinued effective 04/07/2007.

■ The 42A and 42A-S have the same features as the 42 and 42S but are fitted with "Quick Hook-Up" fittings for installation directly into the gauge glass tapings.

Electrical Ratings				
Ampere ratings for the pump and the cut-off circuits				
Motor Duty	120VAC	240VAC	120VDC	240VDC
Full Load	7.4	3.7	2.4	1.2
Locked rotor	44.4	22.2	24.0	12.0
Pilot duty service: 345VA, 120 and 240VAC				

Ampere rating for alarm service			
120VAC	240VAC	120VDC	240VDC
1	1/2	1/2	1/4

Replacements for Old Mercury 42 Series

Replacement snap-switch Order No. shown

Model No.	Discontinued 04/07/2007	Order No.
42	Low-water cut-off/pump control	MH1020
42-A	Same as above w/Quick Hook-Up	MH1021
42-N	Like 42 with gauge glass tapings	MH1019

Complete Snap-Switch Models 42S, 42A-S

Model No.	Description	Order No.
42S	Mercury Free cut-off/pump control	MH1022
42-AS	Same as above w/Quick Hook-Up	MH1023
42S-N	Like 42S with gauge glass tapings	MH1023A

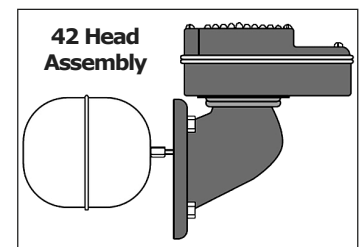
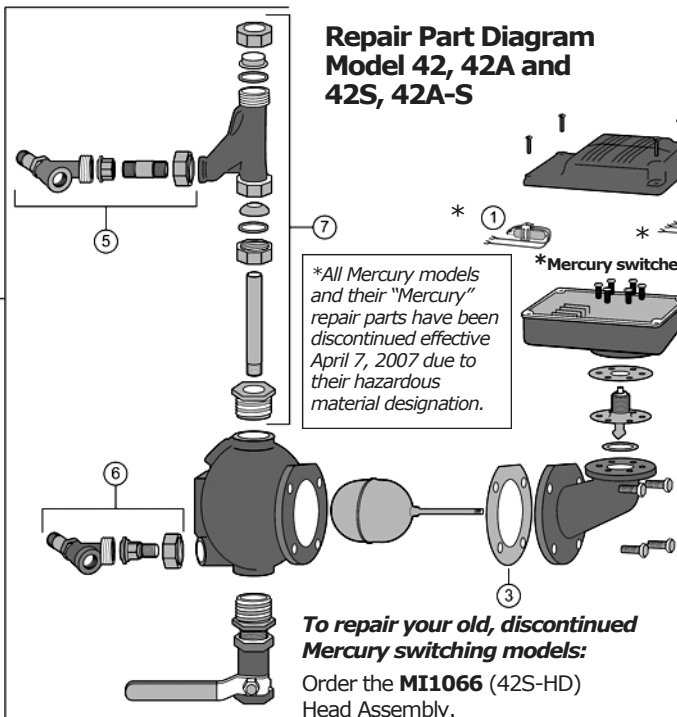

Repair Parts for 42 Series

Item	Description	Order No.
1	2-wire "Mercury" pump switch	No longer available
2	2-wire "Mercury" burner switch "Snap-Switch" for 42S, 42-AS	MI1375C
3	Head gasket	MI1170
4	Quick hook-up (includes 5, 6 & 7)	MI1195
5	Quick hook-up, upper	MI1373
6	Quick hook-up, lower	MI1372
7	Black "Y" assembly	MI1371
Head Assembly with Mercury Switch		Discontinued
Head Assembly with Snap Switch 42S-HD		MI1066

McDonnell-Miller 47 Water Feeders & Cut-Offs

No. 47, 47-2 and 47-2M

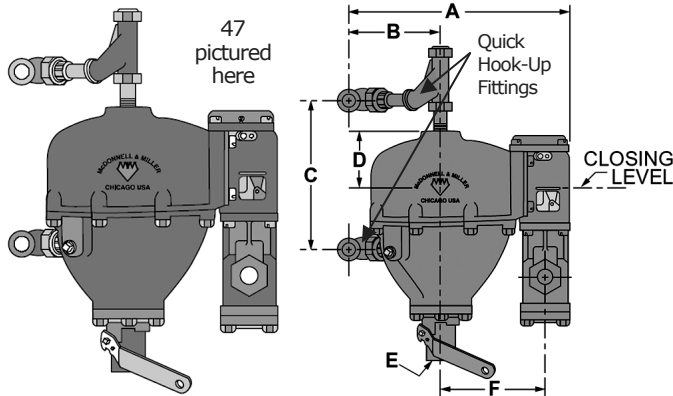

No. 2 Automatic and 2M Manual Switch

Supplied as standard equipment on the 47-2 (**No. 2** automatic reset switch) and the 47-2M (**No. 2M** manual reset switch).

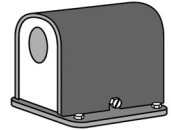

Dimensions of 47 Series (inches)

A	B	C	D	E pipe	F
11-7/8	5-1/4	7 ³ / ₈ to 14 max	2-5/8	3/4	5-1/8

Electrical Ratings, Ampere ratings

Motor Duty	120VAC	240VAC
Full Load	10.2	5.1
Locked rotor	61.2	30.6
Pilot duty service: 345VA, 120 and 240VAC		

Capacity Chart

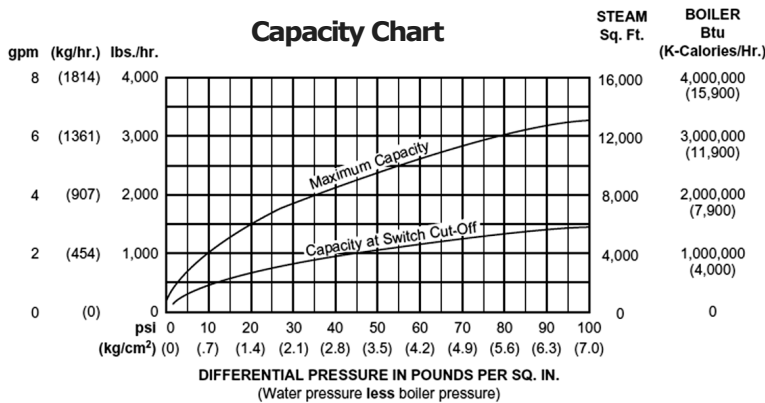

Features of 47, 47-2 and 47-2M

- Used for both steam and hot water boilers with a cold water feed.
- Provides continuous maintenance of safe boiler water level mechanically, independent of electrical service
- No. 2 switch provides automatic reset after a low-water condition; No. 2M switch requires manual reset
- Maximum water supply pressure, 150 psi; maximum operating pressure, 25 psi
- Maximum inlet water temp., 120° F.
- Quick hook-up fittings connect to gauge glass tapings.

Complete Models 47, 47-2, 47-2M

Model No.	Description	Order No.
47	Feeder only, no low water cut-off	MH1025
47-2	Feeder & cut-off, automatic	MH1030
47-2M	Feeder & cut-off, manual reset	MH1024

Repair Parts for Models 47, 47-2, 47-2M

Item	Description	Order No.
1	Cartridge and strainer kit	MI1262
2	Complete valve, cartridge & strainer	MI1260
3	O-Ring	MI1385
4	Strainer assembly with bolts & O-ring	MI1345
5	Complete bellows assembly	MI1250
6	Gasket	MI1050
7	Cam assembly	MI1175
8	No. 2 automatic reset switch	MI1005
9	No. 2M manual reset switch	MI1006
10	Complete Quick Hook-Up (#9, 10 & 11)	MI1200
11	Black "Y" assembly	MI1371
12	Upper Quick Hook-Up fittings	MI1373
13	Lower Quick Hook-Up fitting	MI1372
14	Float	MI1235
15	Gasket	MI1045
16	Blow-down valve	MI1015
17	Gasket for blow-down valve	MI1060

Repair Part Diagram for 47, 47-2, 47-2M

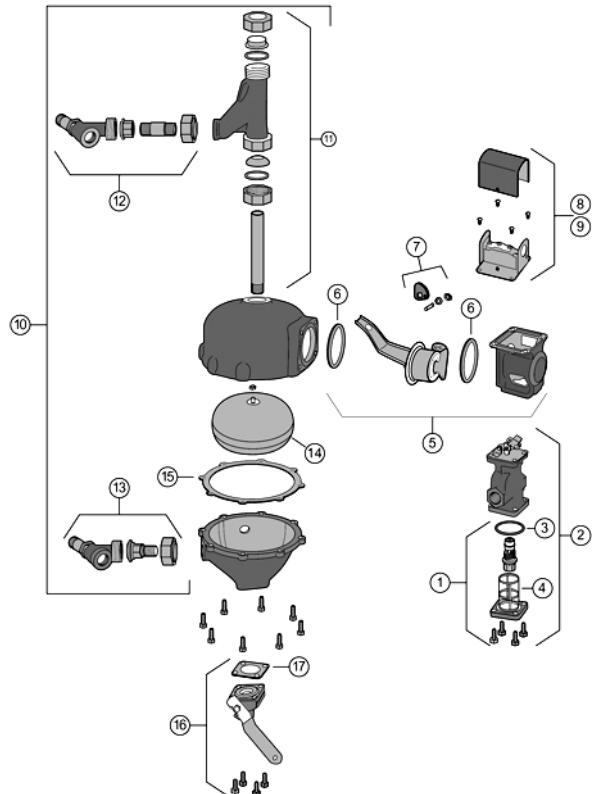

McDonnell-Miller 51 Water Feeder & Cut-Off

No. 51, 51-2 and 51-2M (51-2 shown below)

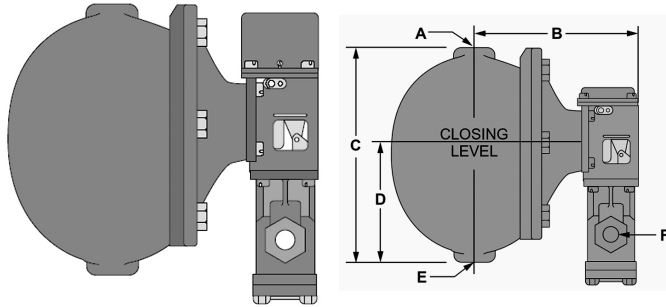

No. 2 Automatic and 2M Manual Switch

Supplied as standard equipment on the 51-2 (No. 2 automatic reset switch) and the 51-2M (No. 2M manual reset switch). Has high voltage terminals for low water cut-off and low water alarm.

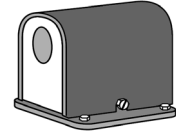

Dimensions of 51-2 Series (inches)

A pipe	B	C	D	E pipe	F pipe
1	8	10-3/8	5-3/4	1	3/4

Electrical Ratings

Ampere ratings for the pump and the cut-off circuits

Motor Duty	120VAC	240VAC	120VDC	240VDC
Full Load	7.4	3.7	2.4	1.2
Locked rotor	44.4	22.2	24.0	12.0

Pilot duty service: 345VA, 120 and 240VAC

Ampere rating for low-water alarm service

120VAC	240VAC	120VDC	240VDC
1	1/2	1/2	1/4

FEEDER DISCHARGE

gpm (kg/hr.) lbs./hr.

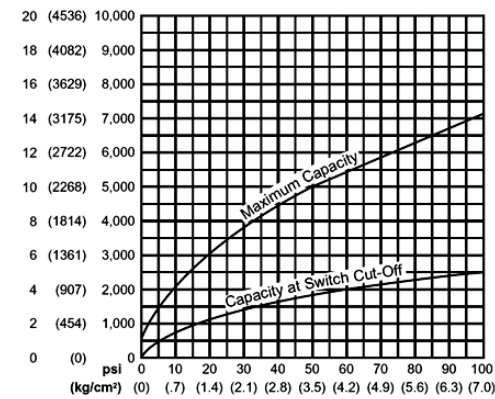

STEAM BOILER
Sq.Ft. hp
(Kilowatts)

40,000	290	(2843)
36,000	261	(2559)
32,000	232	(2274)
28,000	203	(1990)
24,000	174	(1706)
20,000	145	(1421)
16,000	116	(1137)
12,000	87	(853)
8,000	58	(569)
4,000	29	(284)
0	0	0

DIFFERENTIAL PRESSURE IN POUNDS PER SQ. IN.
(Water pressure less boiler pressure)

Features of the Models 51, 51-2 and 51-2M

- For low pressure steam and hot water boilers larger than 5,000 sq. ft. capacity with cold water feed.
- No. 2 (automatic reset) and 2M switch (manual reset) add the low water cut-off function to the series 51
- Max. operating pressure, 35 psi; Max. water supply, 150 psi; Max. inlet water temperature, 120° F.

Repair Parts for 51 Series

Item	Description	Order No.
1	No. 2 switch, automatic reset	MI1005
2	No. 2M switch, manual reset	MI1006
3	*New Style Float (also order MI1265A)	MI1275A
4	Gasket	MI1180
5	Gasket	MI1050
6	Cam assembly	MI1175
7	*New style Bellows bracket (also order the MI1275 float)	MI1265A
8	Valve & strainer kit	MI1280
9	Cartridge strainer kit	MI1282
10	O-Ring	MI1385
11	Strainer basket w/O-Ring	MI1345
	51-HD head assembly, no switch	MI1075
	51-2HD head assembly, #2 switch	MI1080
	51-2MHD head assembly, #2 manual	MI1082

Repair Parts for the 51 series

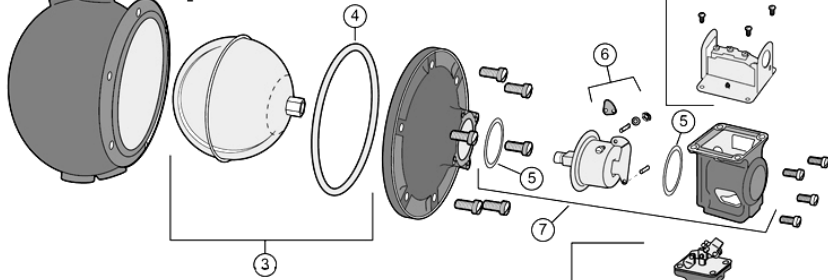

HEAD ASSEMBLY

Model 51-2-HD

Easily repair your boiler control with a **head assembly** — All the operating parts pre-assembled and easily installed. Note: The 51-HD is without #2 switch.

*NOTE: Order a **Float and Bellows Assembly** if your current bellows assembly looks like the one shown to the right. A design change does not allow the new components to fit on old ones.

Old style bellows

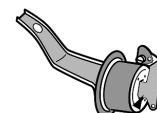

McDonnell-Miller 51S Water Feeder & Cut-Off

No. 51S, 51S-2 and 51S-2M (51S-2 shown below)

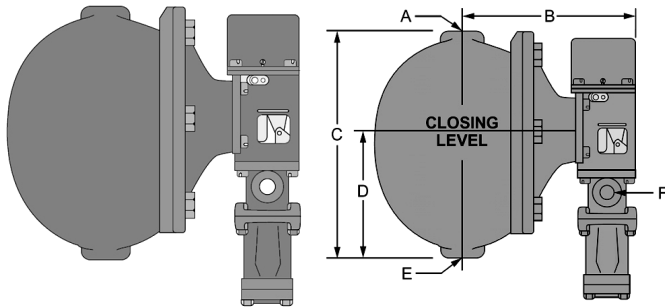

No. 2 Automatic and 2M Manual Switch

Supplied as standard equipment on the 51S-2 (No. 2 automatic reset switch) and the 51S-2M (No. 2M manual reset switch). See the No. 51-2 for the electrical ratings of these switches. The model 51S is a water feeder only.

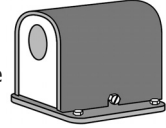

Dimensions of 51S-2 Series (inches)

A pipe	B	C	D	E pipe	F pipe
1	8-1/8	10-3/8	5-3/4	1	3/4

Features of the Models 51S, 51S-2 and 51S-2M

- For low pressure steam and hot water boilers up to 35,000 sq. ft. capacity with **cold water feed**.
- The largest feeding capacity of all McDonnell feeders.
- No. 2 (automatic reset) and 2M switch (manual reset) add the low water cut-off function to the series 51S-2 and 51S-2M, or add a cut-off function to the 51S
- Maximum operating pressure, 35 psi.
- Max. water supply pressure, 150 psi
- Max. inlet water temperature, 120° F.

FEEDER DISCHARGE

gpm (kg/hr.) lbs./hr.

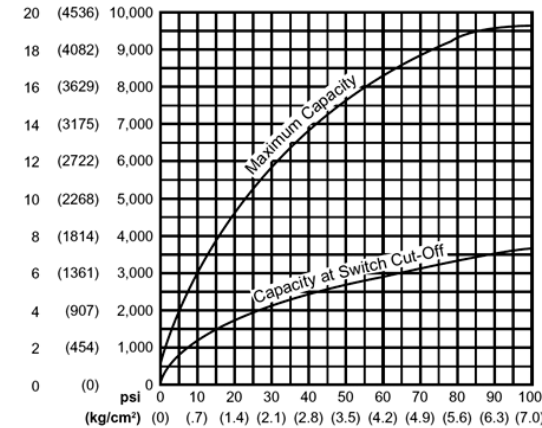

STEAM Sq.Ft. BOILER hp (Kilowatt)

40,000	290 (2843)
36,000	261 (2559)
32,000	232 (2274)
28,000	203 (1990)
24,000	174 (1706)
20,000	145 (1421)
16,000	116 (1137)
12,000	87 (853)
8,000	58 (569)
4,000	29 (284)
0	0

DIFFERENTIAL PRESSURE IN POUNDS PER SQ. IN. (Water pressure less boiler pressure)

Repair Parts for 51S Series

Item	Description	Order No.
1	No. 2 switch, automatic reset	MI1005
2	No. 2M switch, manual reset	MI1006
3	*New style Float (also order MI1265A)	MI1275A
4	Gasket	MI1180
5	Gasket	MI1050
6	Cam assembly	MI1175
7	*New style Bellows bracket assembly (also order MI1275A)	MI1265A
8	Valve assembly	MI1285
9	Valve seat	MI1088
10	Strainer assembly	MI1269
11	Gasket	MI1055
12	O-Ring	MI1385
13	Strainer basket & O-Ring	MI1240
51S Head Assembly		MI1085
51S-2 Head Assembly w/#2 switch		MI1087
51S-2M Head Assembly w/#2M switch		MI1083

Complete 51S, 51S-2 and 51S-2M

Model No.	Description	Order No.
51S	Water feeder only	MH1040
51S-2	Water feeder & cut-off, automatic reset	MH1042
51S-2M	Water feeder & cut-off, manual reset	MH1043

Repair Parts for the 51S series

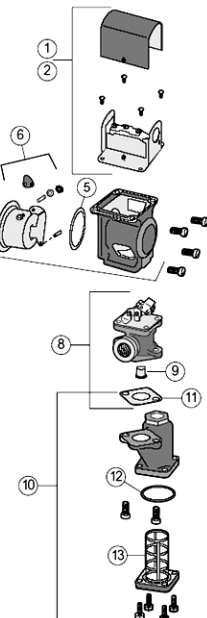
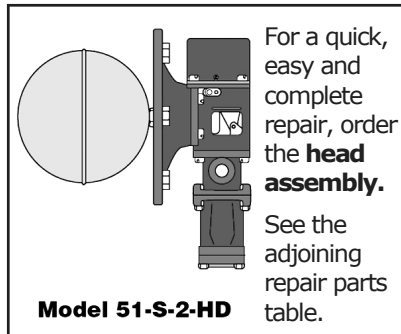
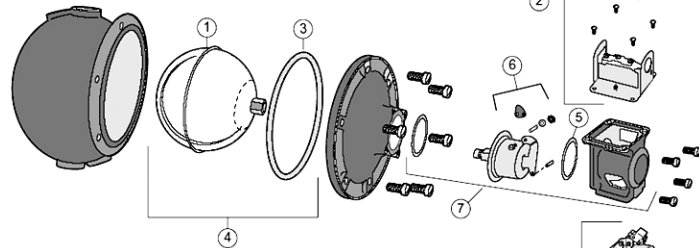

Old style bellows

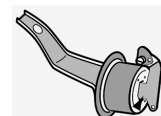

***NOTE: Order a Float and Bellows Assembly** if your current bellows assembly looks like the one shown to the right. A design change does not allow the new components to fit on old ones.

McDonnell-Miller 53 Water Feeder & Cut-Off

No. 53, 53-2 and 53-2M (53-2 shown below)

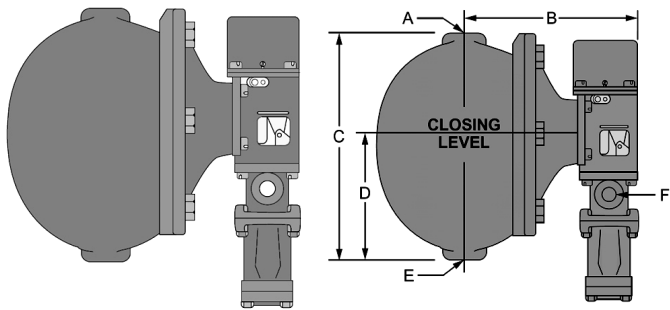

No. 2 Automatic and 2M Manual Switch

Supplied as standard equipment on the 53-2 (No. 2 automatic reset switch) and the 53-2M (No. 2M manual reset switch). The model 53 is a water feeder only. See No. 51-2 page for the electrical ratings of these switches.

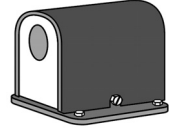

Dimensions of 53 Series (inches)

A pipe	B	C	D	E pipe	F pipe
1	8-1/8	10-3/8	5-3/4	1	3/4

Features of the Models 53, 53-2 and 53-2M

- For higher pressure steam and hot water boilers up to 5,000 sq. ft. capacity and 75 psi with cold water feed.
- Proportional feed action
- No. 2 (automatic reset) and 2M switch (manual reset) add the low water cut-off function to the series 53-2 and -2M, or add a cut-off function to the 53
- Maximum operating pressure, 75 psi; Max. water supply pressure, 150 psi; Max. inlet water temperature, 120° F.

Capacity Chart

FEEDER DISCHARGE

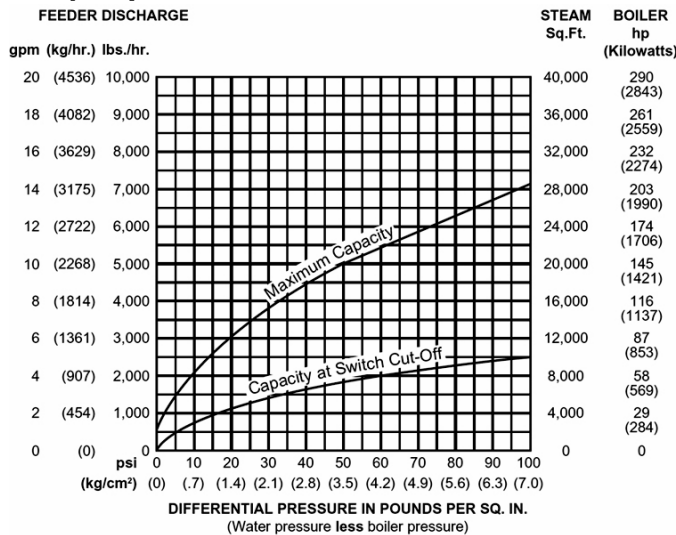

Complete 53, 53-2 and 53-2M

Model No.	Description	Order No.
53	Water feeder only	MH1045
53-2	Water feeder & cut-off, automatic reset	MH1047
53-2M	Water feeder & cut-off, manual reset	MH1048

Repair Parts for 53 Series

Item	Description	Order No.
1	No. 2 switch, automatic reset	MI1005
2	No. 2M switch, manual reset	MI1006
3	Gasket	MI1180
4	Float	MI1277
5	Cam assembly	MI1175
6	Gasket	MI1050
7	*New Style Bellows assembly	MI1293A
8	Valve assembly	MI1294
9	Gasket	MI1055
10	O-Ring	MI1385
11	Strainer Basket	MI1240
53 Head Assembly		MI1090
53-2 Head Assembly with no. 2 switch		MI1093
53-2M Head Assembly with no. 2M switch		MI1093A

Repair Parts for 53 series

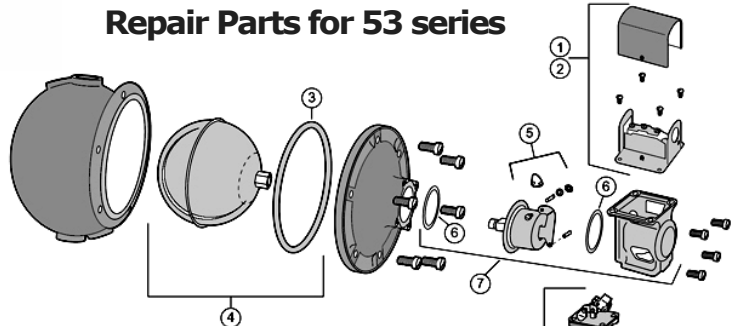

For a quick, easy and complete repair, order the **head assembly**. See the adjoining repair parts table.

Model 53-2-HD

***NOTE: Order a Float and Bellows Assembly** if your current bellows assembly looks like the one shown to the right. A design change does not allow the new components to fit on old ones.

Old style bellows

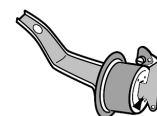

McDonnell-Miller 61 Low Water Cut-Off

No. 61 Low Water Cut-Off

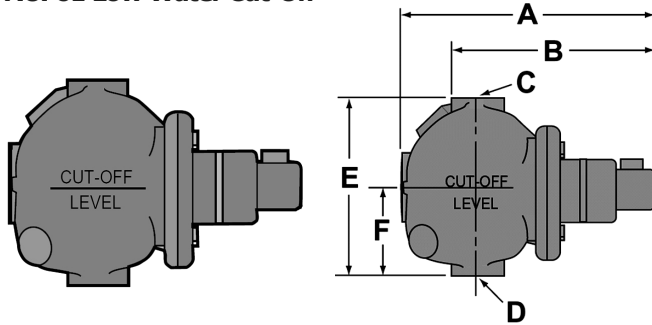

Dimension of 61 (inches)

A	B	C pipe	D pipe	E	F
9-15/16	7-7/16	1	1	6-1/2	3-1/8

Features of the No. 61

- For installation on low pressure steam boilers of any steaming capacity
- Installed with 1" pipe size steam and water equalizing lines
- Dual precision switches for dependable operation of the low water cut-off and alarm or electric water feeder
- Adjustable BX outlet for easy installation
- Maximum steam pressure, 20 psi

Complete No. 61

Model No.	Description	Order No.
61	Low water cut-off for steam boilers with automatic No. 11 re-set switch	MH1050

Repair Part Diagram for the No. 61

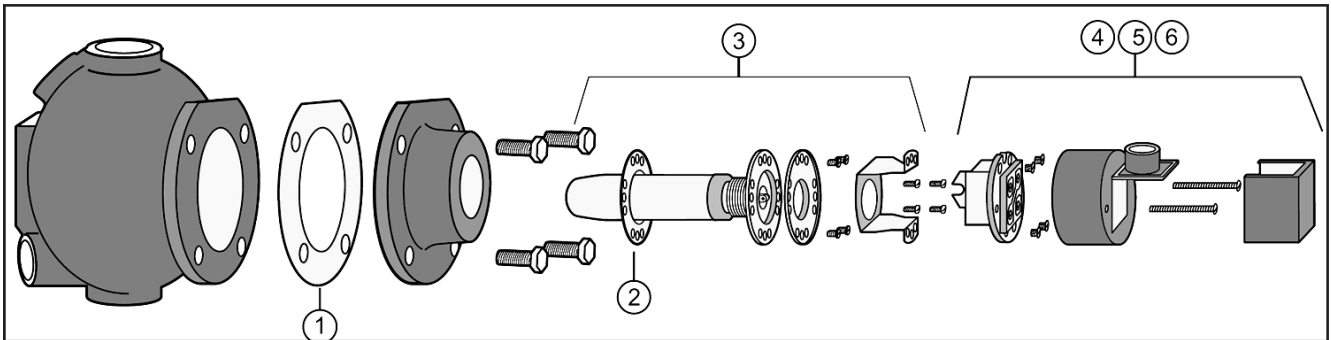

Repair Parts for No. 61

Item	Description	Order No.
1	Head gasket	MI1170
2	Gasket	MI1110
3	Float & bellows assembly	MI1315
4	No. 11 switch, automatic reset	MI1010
5	Kit with cover to convert an automatic reset to a manual reset boiler control	MI1012
6	No. 11-MV switch, millivolt service	MI1013
61-HD	Head assembly	MI1095
6667	Head mechanism, No. 11 switch	MI1160
6667-MV	Head mechanism, No. 11-MV switch	MI1161

HEAD ASSEMBLY

For a quick, easy and complete repair, order the complete **61-HD head assembly**. This component includes the 6667 Head Mechanism (with automatic reset No. 11 switch) and the front-of-bowl flange connection.

Or you can simply order the **6667 head mechanism** with either the No. 11 switch or the No. 11 millivolt switch.

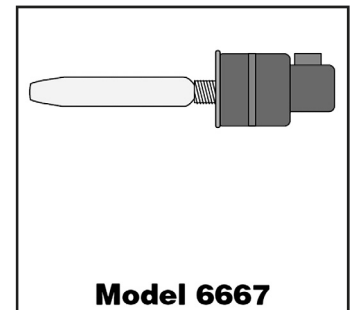
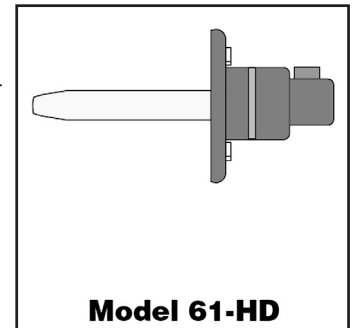

McDonnell-Miller 63 Low Water Cut-Off

No. 63 and 63-M

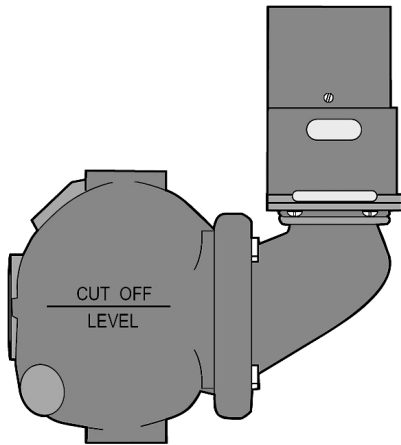

Features of the Models 63 and 63-M

- For steam and hot water boilers. Use with the TC-4 on hot water boilers.
- No. 2 (automatic reset) and 2M switch (manual reset)
- Easy access opening for testing switch operation.
- Maximum operating pressure, 50 psi.
- Max. water supply pressure, 150 psi
- Max. inlet water temperature, 120° F.

No. 2 Switch

Supplied as standard equipment on the 63 (**No. 2** automatic reset switch) and the 63M (**No. 2M** manual reset switch).

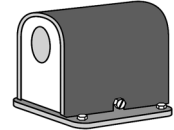

Electrical Ratings for the No. 2 switch

Ampere ratings for the pump and the cut-off circuits

Motor Duty	120VAC	240VAC	120VDC	240VDC
Full Load	7.4	3.7	2.4	1.2
Locked rotor	44.4	22.2	24.0	12.0

Pilot duty service: 345VA, 120 and 240VAC

Ampere rating for low-water alarm service

	120VAC	240VAC	120VDC	240VDC
	1	1/2	1/2	1/4

Complete 63 and 63-M

Model No.	Description	Order No.
63	Low water cut-off, automatic reset	MH1055
63-M	Low water cut-off, manual reset	MH1056

Repair Part Diagram for the 63 series

Repair Parts for 63 Series		
Item	Description	Order No.
1	No. 2 switch, automatic reset	MI1005
2	No. 2M switch, manual reset	MI1006
3	Bellows assembly & gasket	MI1290
4	Gasket	MI1165
5	Float and gasket	MI1300
6	Head Gasket	MI1170
Head Assembly	63 Head Assembly, automatic reset	MI1100
	63-M Head Assembly, manual reset	MI1103

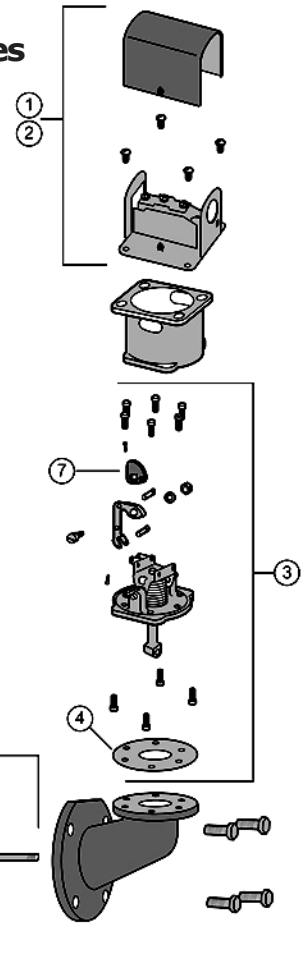

63-HD

For a quick, easy and complete repair, order the **head assembly**.

To order: See the Repair Parts Ordering table.

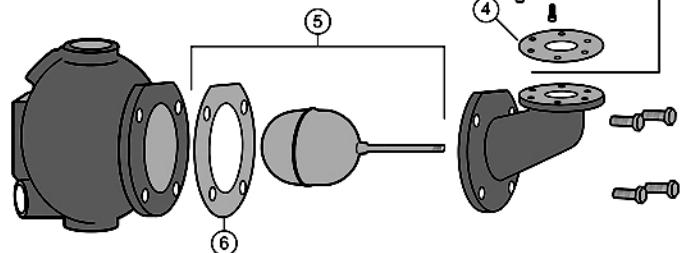

McDonnell-Miller 64 Low Water Cut-Off

No. 64 and 64-M

No. 64A

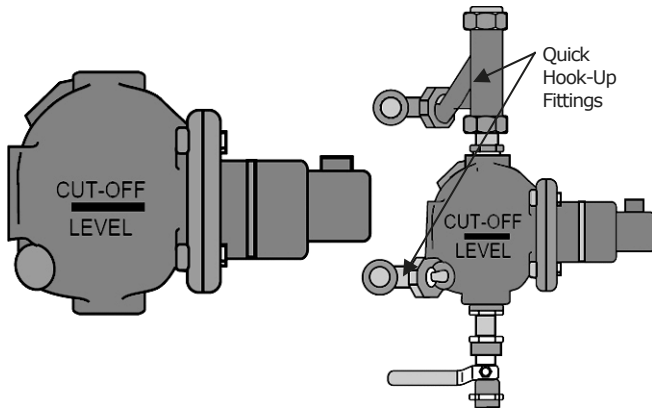

Features of the Models 64, 64-A and 64-M

- For steam and hot water boilers. Use with the TC-4 on hot water boiler systems. 64A has Quick hook-up fittings.
- No. 11 (automatic reset) and 11M switch (manual reset). Dual switches for cut-off and alarm or electric water feeder.
- Uses 1" equalizing pipes.
- Maximum operating pressure, 50 psi.; Max. water supply pressure, 150 psi; Max. inlet water temperature, 120° F.

No. 11 Switch

Supplied as standard equipment on the 64 (**No. 11** automatic reset switch) and the 64M (**No. 11M** manual reset switch).

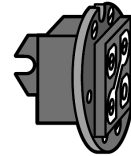

Complete 64, 64-M and 64-A

Model No.	Description	Order No.
64	Low water cut-off, automatic reset	MH1060
64-M	Low water cut-off, manual reset	MH1061
64-A	Low water cut-off, w/Quick Hook-Up	MH1062

Electrical Ratings for the No. 11 switch

Ampere ratings for the pump and the cut-off circuits

Motor Duty	120VAC	240VAC	120VDC	240VDC
Full Load	7.4	3.7	2.4	1.2
Locked rotor	44.4	22.2	24.0	12.0

Pilot duty service: 345VA, 120 and 240VAC

Ampere rating for low-water alarm service

120VAC	240VAC	120VDC	240VDC
1	1/2	1/2	1/4

Repair Parts for 64 Series

Item	Description	Order No.
1	Float assembly	MI1310
2	Head gasket	MI1170
3	Bellows assembly	MI1305
4	Gasket	MI1110
5	Automatic #11 switch	MI1010
6	Conversion kit: needed when changing from automatic to manual switch	MI1012
7	Millivolt service, #11 switch	MI1013
8	Quick hook-up fittings, complete	MI1200
9	Upper Quick hook-up fittings	MI1373
10	Lower Quick hook-up fittings	MI1372
11	Black "Y" assembly	MI1371
Head Assembly	64 head assembly, automatic reset	MI1105
	64M head assembly, manual reset	MI1105A

Repair Part Diagram for 64 series

Head Assembly:
the easiest way to repair your series 64 boiler controls.

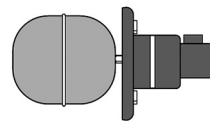

64-HD

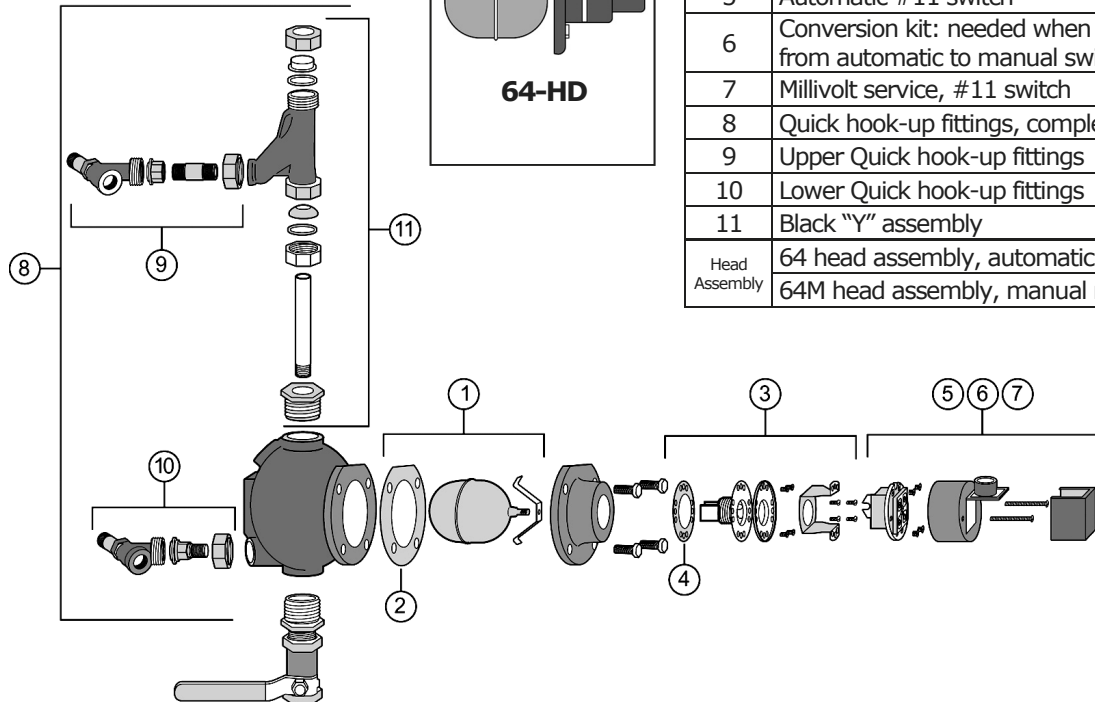

McDonnell-Miller 67 Low Water Cut-Off

No. 67, 67G and 67-M

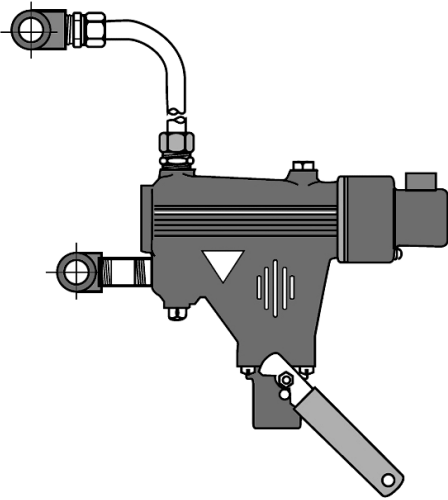

Features of the Models 67, 67G and 67-M

- For steam boilers any size.
- Most widely used control of its kind.
- Quick hook-up fittings connect to gauge glass tapings.
- No. 11 (automatic reset) and 11M switch (manual reset).
- Dual switches for cut-off and alarm or electric water feeder.
- Max. steam operating pressure, 20 psi.

No. 11 Switches

Supplied as standard equipment on the 67 and 67LQHU (**No. 11** automatic reset switch), 67G (**No. 11MV** millivolt) and the 67M (**No. 11M** manual reset switch).

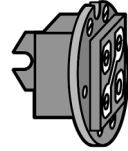

Electrical Ratings for the No. 11 switch

Ampere ratings for the pump and the cut-off circuits

Motor Duty	120VAC	240VAC	120VDC	240VDC
Full Load	7.4	3.7	2.4	1.2
Locked rotor	44.4	22.2	24.0	12.0

Pilot duty service: 345VA, 120 and 240VAC

Ampere rating for low-water alarm service

120VAC	240VAC	120VDC	240VDC
1	1/2	1/2	1/4

Complete 67, 67-G and 67-M		
Model No.	Description	Order No.
67	Low water cut-off, automatic reset	MH1065
67-G	Low water cut-off, millivolt service	MH1066
67LQHU	Cut-off <u>without</u> Quick Hook-Up fittings	MH1067
67-M	Low water cut-off, w/Quick Hook-Up	MH1068

Repair Parts for 67 Series

Item	Description	Order No.
1	Upper Quick hook-up assembly	MI1312
2	Complete Quick hook-up assembly	MI1205
3	Head gasket	MI1110
4	Float and bellows assembly with gasket	MI1315
5	Standard switch, No. 11	MI1010
6	Switch with manual reset, No. 11M	MI1012
6	Conversion kit needed when changing from an automatic to manual switch	MI1012
7	Switch for millivolt service, No. 11MV	MI1013
8	Blow down valve with gasket	MI1015
9	Gasket only, for blow down valve	MI1060
Head Assembly	6667 head mechanism, standard voltage	MI1160
	6667MV head mechanism, millivolt service	MI1161

Repair Part Diagram for 67 series

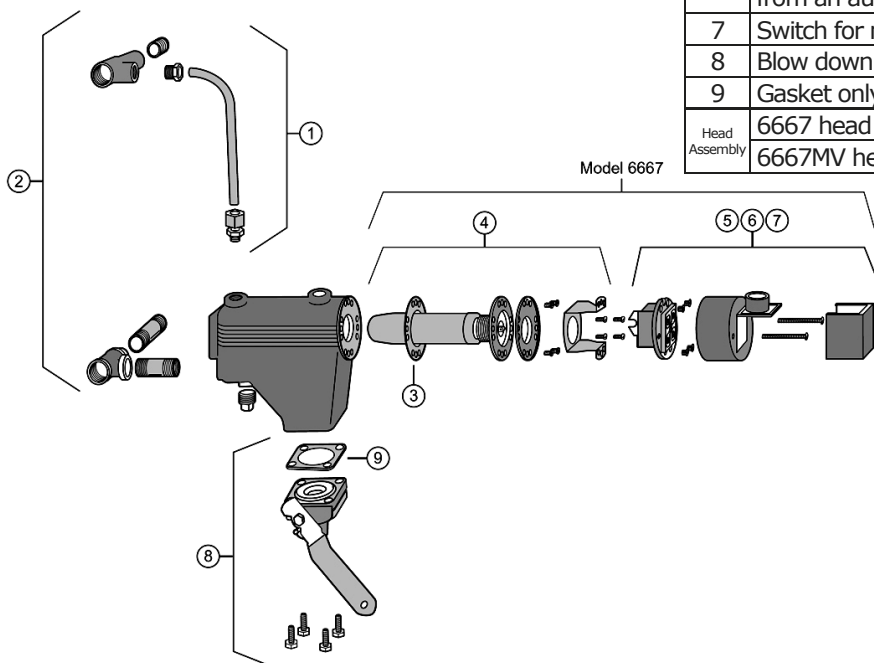

Head Assembly:

the easiest way to repair your series 67 boiler controls. Re-use your current, piped-in "bowl," remove the old head, bolt-in the new one — Done!

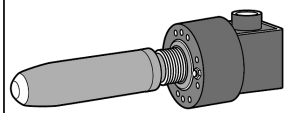

6667

McDonnell-Miller 69 Built-In Low Water Cut-Off

Series 69 Built-In Cut-Off

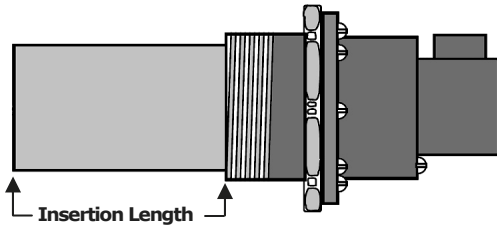

Installs into a boiler's 2 1/2" side tapping

Complete 69 Series Built-In Cut-Offs

Model No.	Description	Insertion Length	Order No.
69	Water cut-off, No. 11 switch	4-1/8"	MH1070
69MVP	Water cut-off, No. 11MV switch	4-1/8"	—
169	Water cut-off, No. 11 switch	3-1/8"	MH1105J
269	Water cut-off, No. 11 switch	2-1/4"	MH1112
369	Water cut-off, No. 11 switch	1-3/4"	MH1112A
369MV	Water cut-off, No. 11MV switch	1-3/4"	—
469	Water cut-off, No. 11 switch	1-3/16"	MH1112B
569	No. 469 with 1/4" tapping	1-3/16"	MH1114

Repair Parts for 69 Series

Item	Description	Order No.
1	Shield assembly, not available separately	MI1316
2	Gasket	MI1115
3	O-Ring	MI1116
4	O-Ring	MI1117
5	Gasket	MI1110
6	No. 11 automatic reset switch	MI1010
7	No. 11-M manual reset switch	MI1012
8	No. 11-MV switch for millivolt service	MI1013
9	Float and bellows assembly	MI1315
No. 6667 Head Mechanism for all 69 series except the 69MVP		MI1160
No. 6667-MV Head Mechanism for the 69MVP		MI1161

Features of the Series 69

- For steam boilers any steaming capacity.
- Adjustable BX outlet for easy electrical wiring.
- Installs into a boiler's 2-1/2" NPT side tapping.
- No. 11 (automatic reset), No. 11M (manual reset) and 11MV (millivoltage service).
- Dual switches for cut-off and alarm or electric water feeder.
- Max. steam operating pressure, 20 psi.
- Order the appropriate head mechanism to easily repair the corresponding 69 series .

No. 11 Automatic and 11MV Millivolt Switch

Supplied as standard equipment on the 69, 169, 269, 369, 469 and 569 (No. 11 automatic reset switch). The No. 11MV millivolt switch is supplied with the 69MVP and the 369MV.

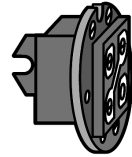

Electrical Ratings for the No. 11 switch

Ampere ratings for the pump and the cut-off circuits

Motor Duty	120VAC	240VAC	120VDC	240VDC
Full Load	7.4	3.7	2.4	1.2
Locked rotor	44.4	22.2	24.0	12.0

Pilot duty service: 345VA, 120 and 240VAC

Ampere rating for low-water alarm service

120VAC	240VAC	120VDC	240VDC
1	1/2	1/2	1/4

Replacement Head Mechanism

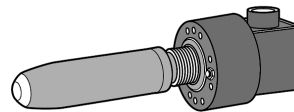

6667

The easiest way to repair your McDonnell-Miller boiler controls: Simply unscrew the old one, insert the new one — you're done!

Repair Part Diagram for 69 series

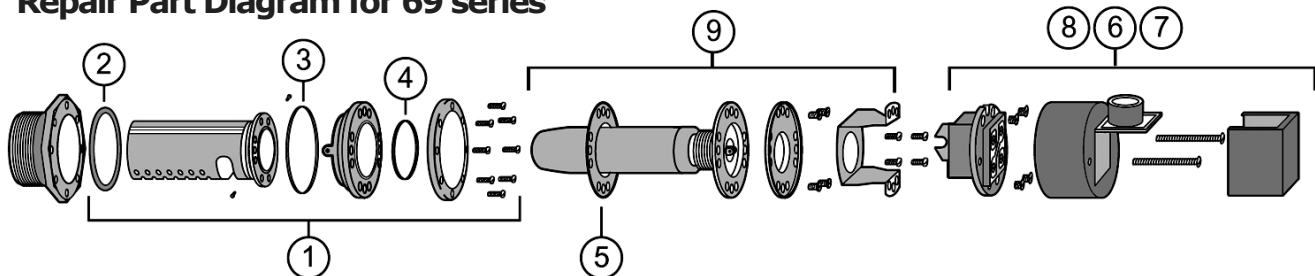

McDonnell-Miller 70 Low Water Cut-Off

Series 70 Built-In Cut-Off — OBSOLETE



Model 70

Model 70-B

The 70 series of built-in low water cut-offs have been discontinued.

The model 569 is the functional replacement.

Complete 70 Series Built-In Cut-Offs

Model No.	Description	Order No.
70	Low water cut-off	Obsolete
70B	Low water cut-off with blow-down valve	Obsolete

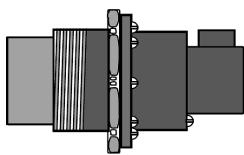

Replaces the 70 & 70B

Complete 569

Description	Order No.
Built-in low water cut-off for a boiler's 2-1/2" side tapping & 1-3/16" insertion length.	MH1114

Repair Parts available for 70 Series

Item	Description	Order No.
1	Lever-handle Blow down valve	MI1015
2	Gasket	MI1060
4	Gasket	MI1110
5	No. 11 automatic reset switch	MI1010
6	No. 11-M manual reset switch	MI1012
7	No. 11-MV switch for millivolt service	MI1013
8	Float and bellows assembly	MI1315
9	No. 6667 Head Mechanism	MI1160
10	No. 6667MV Head Mechanism (millivolt)	MI1161

Features of the Discontinued Series 70/70B

- For steam boilers any steaming capacity.
- Adjustable BX outlet for easy electrical wiring.
- Installs into a boiler's 2-1/2" NPT side tapping.
- Dual switches for cut-off and alarm or electric water feeder, and 1/4" npt pressure control tapping.
- Max. steam operating pressure, 20 psi.
- Model 569 replaces the 70/70B low water cut-off.

No. 11 Switch

Supplied as standard equipment on both the model 70 and 70B. Choose from automatic or manual reset, or select millivolt service.

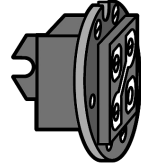

Electrical Ratings for the No. 11 switch				
Ampere ratings for the pump and the cut-off circuits				
Motor Duty	120VAC	240VAC	120VDC	240VDC
Full Load	7.4	3.7	2.4	1.2
Locked rotor	44.4	22.2	24.0	12.0
Pilot duty service: 345VA, 120 and 240VAC				

Ampere rating for low-water alarm service			
120VAC	240VAC	120VDC	240VDC
1	1/2	1/2	1/4

Replacement Head Mechanism

The easiest way to repair your McDonnell-Miller boiler controls: Simply unscrew the old one, insert the new one — you're done!



6667

Repair Part Diagram for 70 series

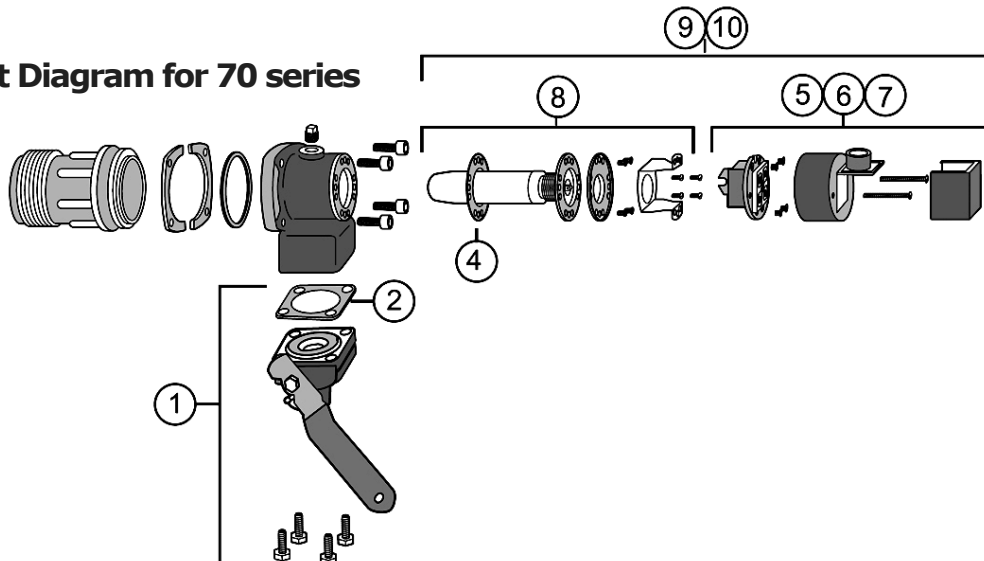

McDonnell-Miller 93, 94, 193 & 194 Controls

No. 93 and 94 Pictured Below

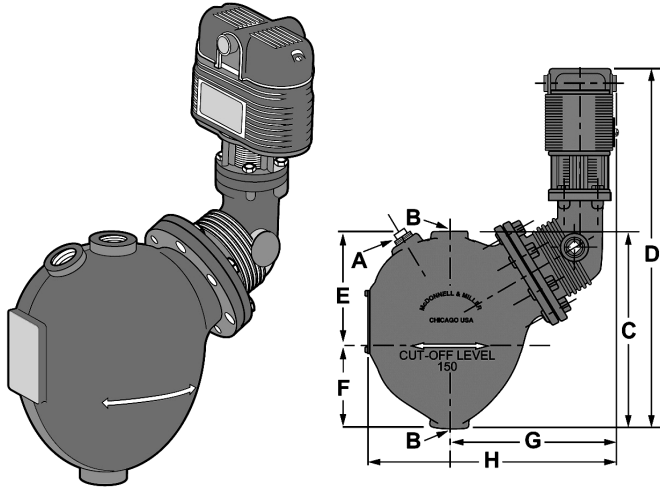

Rated to 150 psi steam

No. 193 and 194 Pictured Below

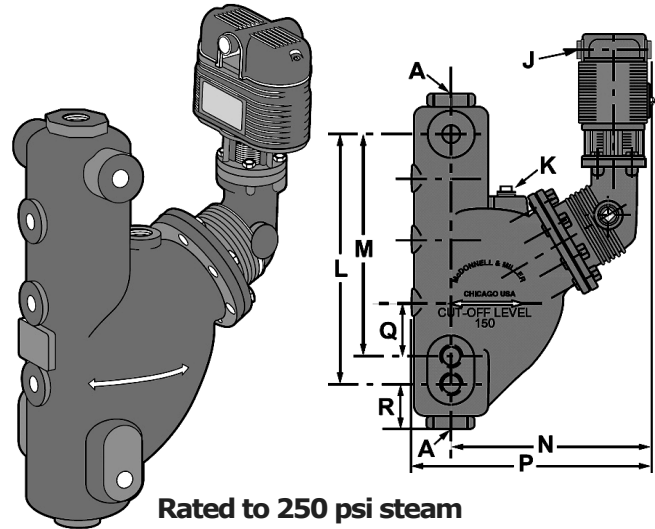

Rated to 250 psi steam

Dimensions for Model 93 and 94

A	B	C	D	E	F	G	H
3/4 pipe	1 pipe	10-1/16	18 5/8	4 1/2	5-5/8	8-7/8	12-7/8

93 & 193 Cut-Off & Pump Control Features:

- For high pressure steam boilers of any steaming capacity up to **150 psig.** 1" pipe connections.
- The standard No. 5 switch has two SPDT switches for operation at two different water levels. Manual re-set switch (5M) after low-water conditions available.
- The No. 7B switch has one SPDT switch for low water cut-off or alarm; the proportional signal ensures a constant water line. Manual re-set switch (7BM) available.
- The switch is isolated from steam cavity.
- Maintains consistent water regardless of pressure.
- Magnetic repulsion operation eliminates the need for a bellows assembly, ensuring dependable operation at the higher pressures encountered.
- The 193 series has a built-in water column with tappings for gauge glass and tri-cocks.

Dimensions for Model 193 and 194

A	J	K	L	M	N	P	Q
1 pipe	1/2 pipe	3/4 pipe	12 3/4	11 1/2	10 13/16	13	2 1/4

94 & 194 Cut-Off & Pump Control Features:

- For high pressure steam boilers of any steaming capacity up to **250 psig.** 1-1/4" pipe connections.
- The standard No. 5 switch has two SPDT switches for operation at two different water levels. Manual re-set switch (5M) after low-water conditions available.
- The No. 7B switch has one SPDT switch for low water cut-off or alarm; the proportional signal ensures a constant water line. Manual re-set switch (7BM) available.
- The switch is isolated from steam cavity.
- Maintains consistent water regardless of pressure.
- Magnetic repulsion operation eliminates the need for a bellows assembly, ensuring dependable operation at the higher pressures encountered.
- The 194 series has a built-in water column with tappings for gauge glass and tri-cocks.

Complete Model 93 and 193

Model No.	Description	Order No.
93	Cut-Off/Controller with No. 5 switch	MH1075
93-M	No. 93 with Manual Reset 5M switch	MH1074
93-7B	No. 93 with No. 7B switch	MH1076
93-7B-M	No. 93 with Manual Reset 7BM switch	MH1077
193	Cut-Off/Controller with No. 5 switch	MH1105K
193-M	No. 193 with Manual Reset 5M switch	MH1105L
193-7B	No. 193 with No. 7B switch	MH1105M
193-7BM	No. 193 with Manual Reset 7BM switch	MH1105X

Complete Model 94 and 194

Model No.	Description	Order No.
94	Cut-Off/Controller with No. 5 switch	MH1080
94-M	No. 94 with Manual Reset 5M switch	MH1079
94-7B	No. 94 with No. 7B switch	MH1081
94-7B-M	No. 94 with Manual Reset 7BM switch	MH1081A
194	Cut-Off/Controller with No. 5 switch	MH1106
194M	No. 194 with Manual Reset 5M switch	MH1106A
194-7B	No. 194 with No. 7B switch	MH1106B
194-7BM	No. 194 with Manual Reset 7BM switch	MH1106C

McDonnell-Miller 93, 94, 193 & 194 Repair Parts

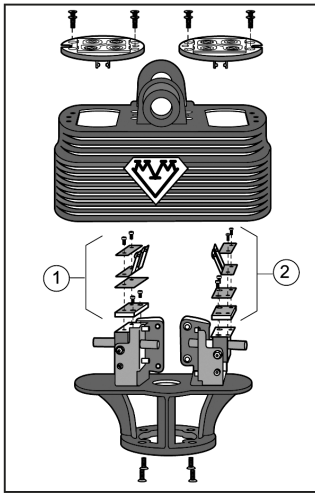

No. 5 Replacement Switch

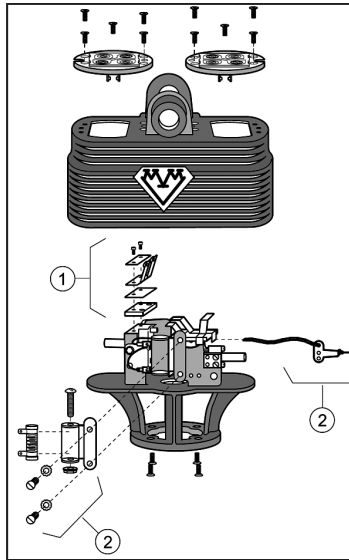

No. 7B Replacement Switch

Switches & Repair Parts

No. 5 Switch and Parts

1	Burner switch contact assembly	MI1320
2	Pump switch contact assembly	MI1325

No. 5 switch complete **MI1008**

No. 5M (manual) switch complete **MI1008A**

No. 7B Switch and Parts

1	Burner switch contact assembly	MI1320
2	Resistor Wire Assembly	MI1009B

No. 7B switch complete **MI1009**

No. 7BM (manual) switch complete **MI1009A**

Repair Parts for 93, 94, 193 & 194

Item	Description	Order No.
Repair Parts for 93 and 193		
1 & 4	Head mechanism, No. 5 switch	MI1130
1	Head mechanism <u>less</u> switch	MI1132
1 & 6	Head mechanism, No. 7B switch	MI1131
2	Float and gasket (item no. 3)	MI1336
3	Gasket	MI1140
4	No. 5 switch assembly	MI1008
5	No. 5M switch assembly	MI1008A
6	No. 7B switch assembly	MI1009
7	No. 7BM switch assembly	MI1009A
Repair Parts for 94 and 194		
1 & 4	Head mechanism, No. 5 switch	MI1133
1	Head mechanism <u>less</u> switch	MI1133A
1 & 6	Head mechanism, No. 7B switch	MI1134
2	Float and gasket (item no. 3)	MI1336
3	Gasket	MI1125
4	No. 5 switch assembly	MI1008
5	No. 5M switch assembly	MI1008A
6	No. 7B switch assembly	MI1009
7	No. 7BM switch assembly	MI1009A

Repair Parts Diagram for 93, 94, 193 and 194

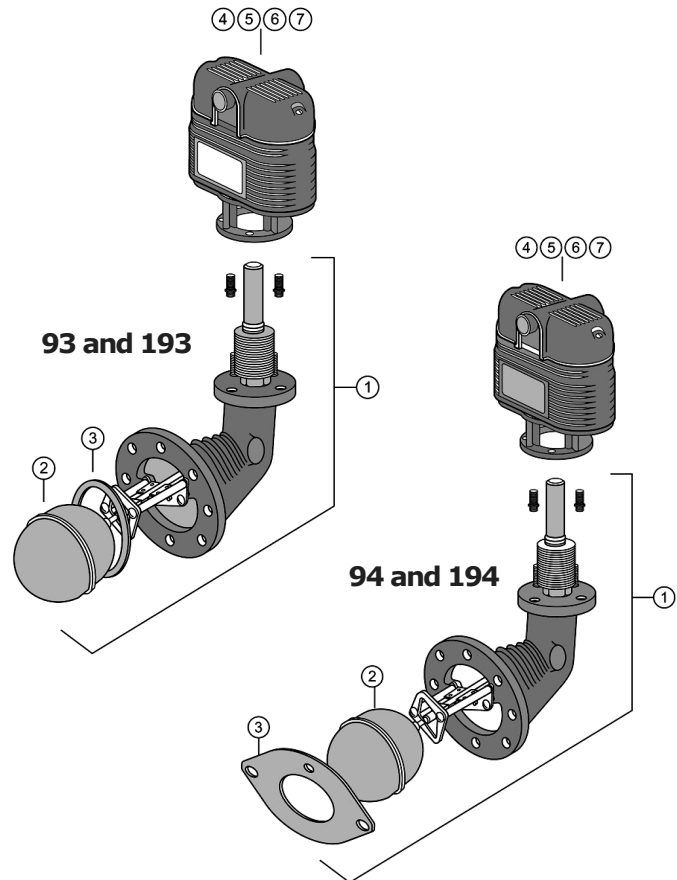

No. 5 and 7B switches automatically re-set after a low-water condition.

No. 5M and 7BM need to be manually re-set after a low-water condition.

McDonnell-Miller 101A Water Feeder

No. 101A

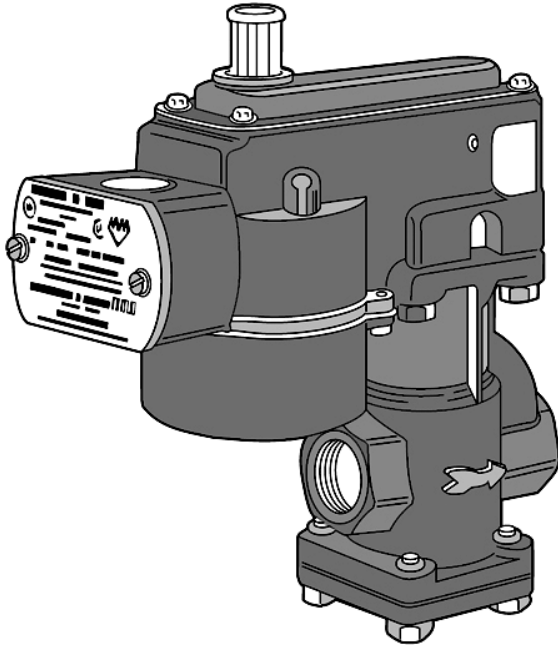

The No. 101A Electric Water Feeder is designed for use on steam boilers up to 5,000 square foot capacity. The installation of the 101A, along with a low water cut-off, converts each of these separate components into the functional equivalent of a low water cut-off and water feeder combination.

The low water cut-off will turn off the burner if the boiler water level drops below the safe water line of the boiler. However, the low water cut-off will send a signal to the 101A water feeder to "send me water" before the low water cut-off reaches the point of burner shut-off. The No. 11 switch in the 101A water feeder operates at a level slightly higher than the low water cut-off point.

Features of the 101A

- Closes tight against supply pressures up to 150 psi.
- For Oil-fueled boilers: Order the standard 101A. Furnished with a 120VAC coil.
- For Gas-fueled boilers having 24 volt control circuits: Order the 101A-24V which includes the electrical transformer.
- Maximum boiler size: 5,000 square foot steam.
- For steam boilers to 25 psi with a cold water feed
- Can be used with mechanical or electronic low water cut-offs (do not use with manual reset low water cut-offs)
- Manual feed button to add water manually
- Maximum water supply pressure, 150 psi
- Maximum inlet water temperature, 120° F
- Maximum power consumption (during water feed)
 - 40 volts @ 24 volt operation
 - 40 volts @ 120 volt operation

Complete Model 101A and 101A-24V		
Model No.	Description	Order No.
101A	Water feeder, 120 volt	MH1085
101A-24V	Water feeder, 24 volt	MH1090

Repair Parts for 101A, 101A-24V		
Item	Description	Order No.
1	Cartridge and strainer kit	MI1262
2	O-Ring	MI1385
3	24 volt transformer for 101A-24V	HN1195
4	Strainer with bolts and O-Ring	MI1345

Water Flow Data

Supply Pressure Differential in PSI	Flow Rate in GPM
10	1.7
20	2.1
40	2.9
60	3.4

101A Repair Parts Diagram

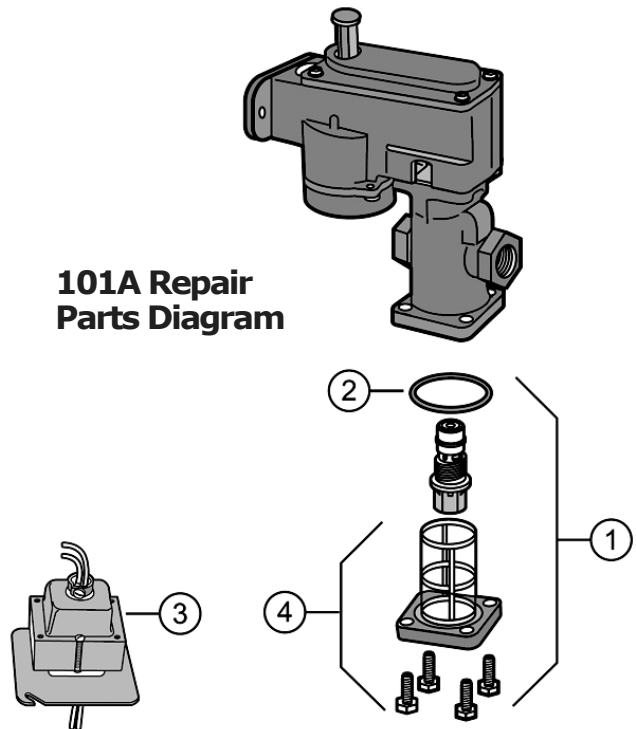

McDonnell-Miller 150 & 157 Cut-Off/Pump Control

Snap Switch Models

Mercury Switch Models Discontinued!



150 Series

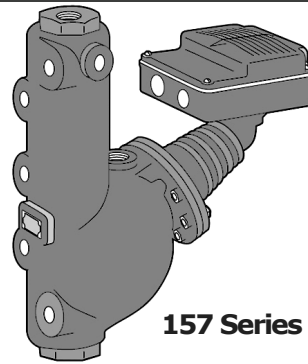
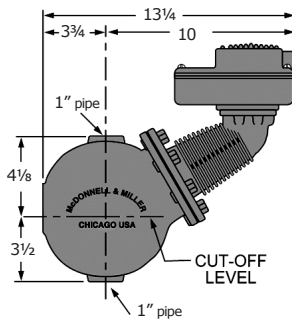

157 Series

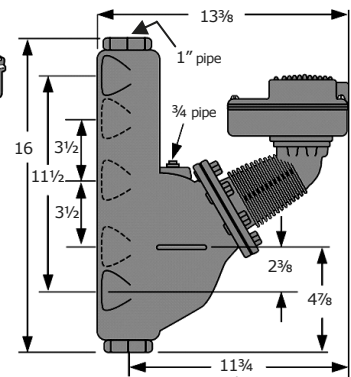

Complete Model 150 and 157 and Head Mechanisms

Model No.	Description	Complete Order No.	Head Mechanism
150S & 157S with Snap Switches			
150S	Cut-Off/Pump Controller—Snap	MH1095	MI1145
150S-M	150S With manual reset	MH1097	MI1147
150S-MD	150S with Maximum Differential — Prevents nuisance burner shutdown	MH1096	MI1147A
150S-M-MD	150S-MD with manual reset	172802	MI1147B
157S	150S with built-in water column	MH1100	MI1145
157S-M	157S with manual reset	MH1102	MI1147
157S-MD	157S with Maximum Differential — Prevents nuisance burner shutdown	MH1103	MI1147A
157S-M-MD	157S-MD with manual reset	175412	MI1147B
157SRBPMD	157S-MD w/integral sensing probes	MH1104	*MI1147A
158 & 159 with Double Snap Switches			
158-S	150S with 2 SPDT switches	MH1105D	MI1148B
158-S-M	150S with manual reset	178502	MI1148C
159-S	150S with 2 SPST switches	MH1105F	MI1149B
Replacements for Old Style 150 & 157 with Mercury Switches <i>Replacement Snap Switch models shown.</i>			
150	Cut-off/Pump Controller—Mercury	MH1095	MI1145
150-M	150 with manual reset	MH1097	MI1147
150-MD	150 with Maximum Differential — Prevents nuisance burner shutdown in low-pressure applications	MH1096	MI1147A
150-M-MD	150 with manual reset and maximum differential for low pressure	172802	MI1147B
157	150 with built-in water column	MH1100	MI1145
157-M	157 with manual reset	MH1102	MI1147
157-MD	157 with maximum differential	MH1103	MI1147A
157-M-MD	157 with manual reset and maximum differential for low pressure	175412	MI1147B
157RBPMD	157MD with integral sensing probes	MH1104	*MI1147A
Replacements for Old 158 & 159 with Double Mercury Switches <i>Replacement Snap Switch models shown.</i>			
158	150 with 2 SPDT mercury switches	MH1105D	MI1148B
158-M	158 with manual reset	178502	MI1148C
159	150 with 2 SPST mercury switches	MH1105F	MI1149B

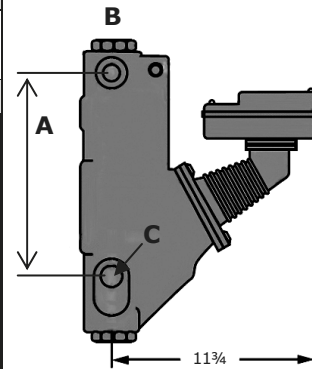

157R & 157RL side-mount gage glass tappings

Gauge glass tappings are located on the side of the body on both the 157R and 157RL.

Tapping Sizes and "A" for Series 157

Product No.	157	157A	157RL
A Dimension	11 1/2"	11 1/2"	12 3/4"
B Equalizing tappings	1" npt	1 1/4" npt	1 1/4" npt
C Gauge glass & tri-cock tappings	1/2" npt	3/4" npt	1/2" npt

Head Mechanism

Convert your old mercury models into Snap-Switch models:

Replace the head mechanism!

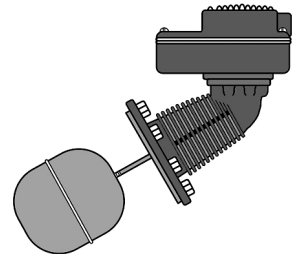

Features of 150 and 157

■ Mercury switch models are no longer available for sale as of April 7, 2007 due to "hazardous material" classification.

- For steam boilers any steaming capacity in low or high pressures.
- Model 157 has a built-in water column
- Units with Snap Switches are Mercury Free! The snap switch replaces the old, hazardous material mercury switches.
- Units with Manual Reset need to be "manually reset" to an operational condition after a low-water condition shuts down burner.
- Max. steam operating pressure, 150 psi.

*Order the integral sensing probes separately

McDonnell-Miller 150 & 157 Repair Parts

No. 150 & 157 Repair Parts — Mercury Switches

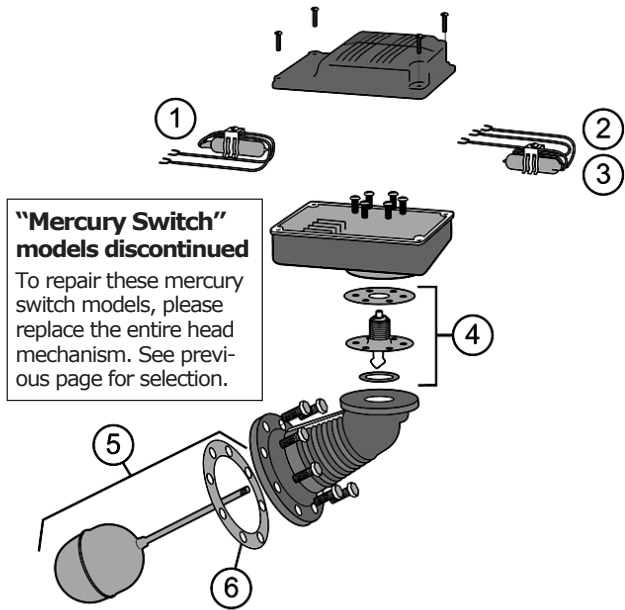

"Mercury Switch" models discontinued

To repair these mercury switch models, please replace the entire head mechanism. See previous page for selection.

No. 150S & 157S Repair Parts — Snap Switches

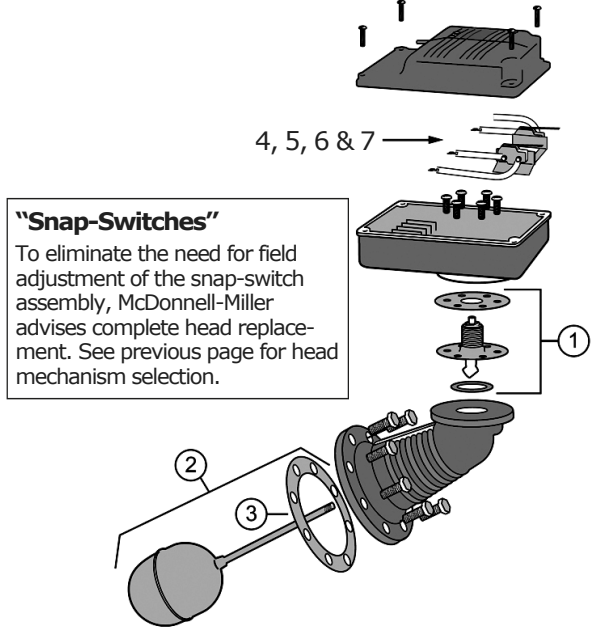

"Snap-Switches"

To eliminate the need for field adjustment of the snap-switch assembly, McDonnell-Miller advises complete head replacement. See previous page for head mechanism selection.

Repair Parts for 150 & 157 Mercury Switch		
Part No.	*Mercury Discontinued 04/07/07	Order No.
1	Mercury switch, 2-wire	No longer available.
2	Mercury switch, 3-wire	
3	Mercury switch, 3-wire, manual reset	
4	Bellows assembly	MI1360
5	Float & rod assembly (includes gasket)	MI1355
6	Head Gasket (standard ring gasket)	Use MI1140
7	Head Gasket (8-hole bolt gasket)	MI1140
Repair Electrodes for the 157-BRP		
8	Short electrode for 157-RBP only	MI1176A
9	Long electrode for 157-RBP only	MI1176
10	Level control module for 157-RBP only	MI1530

Repair Parts for 150S & 157S Snap Switch		
Part No.	Description	Order No.
1	Bellows assembly	MI1360
2	Float & rod assembly (includes gasket)	MI1355
3	Head Gasket (8-hole bolt gasket)	MI1140
4	Snap switch for 150S	MI1376
—	Snap switch for 150S-MD <i>Not shown</i>	MI1377A
5	Snap switch for 150S-M styles	*N/A
6	Snap switch for 158S styles	MI1378
7	Snap switch for 158S-M styles	310469
—	Snap switch for 159S <i>Not shown</i>	MI1378B

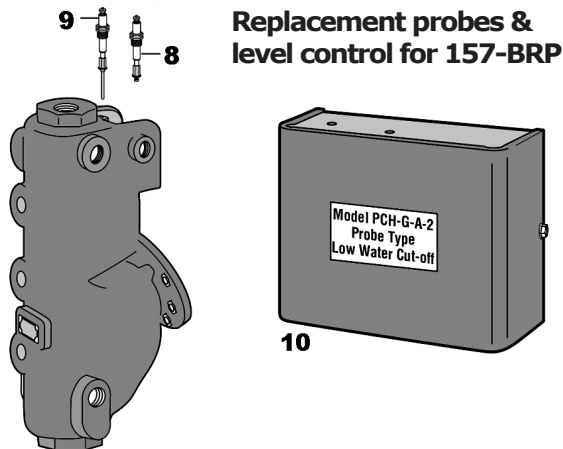

Replacement probes & level control for 157-BRP

Replacement Snap Switches

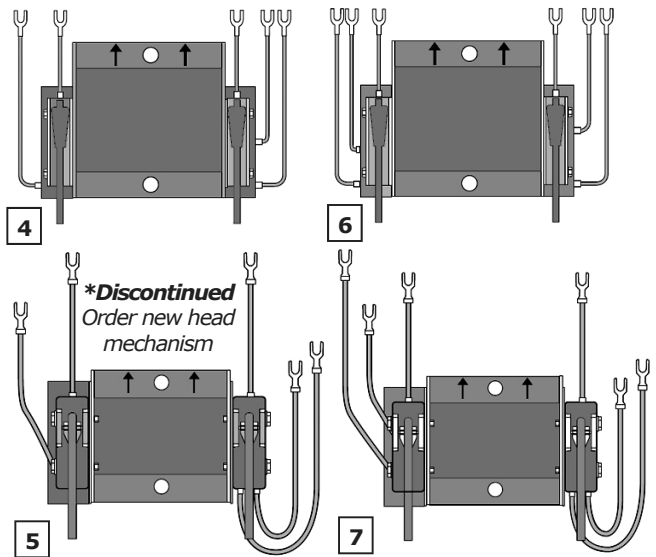

Convert Your Old 150 or 157 Mercury or Snap Models



Convert your old Mercury or Snap-Switch Models into New Electronic Probe Control Models!

Replacement 150E Head Assemblies

Model No.	Description	Head Assembly
150E	Cut-Off/Pump Controller	MI1141A
150E-M	150E With Manual Re-set	MI1141B

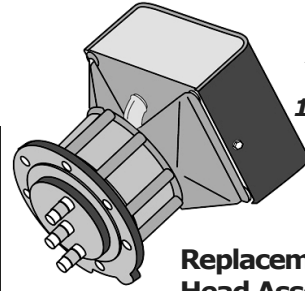

Fits on your old 150 and 157 units!

Replacement 150E Head Assembly

Wiring connections for a Series 150E/157E when used as a replacement for a Series 150/157 (mercury) or 150S/157S (snap) switch unit.

NOTE

Read and follow installation instructions included with 150E/157E control.

- A. Connect 'Hot' (L1) wire from power supply to Terminal 'H'.
- B. Connect 'Neutral' (L2) wire from power supply to Terminal 'N'.

NOTE: Power wires connected to Terminals 'H' and 'N' on 150E should be from the boiler's control transformer connections which are usually designated 'L1' and 'L2'. The 150E **SHOULD NOT** be powered as part of any operating or safety circuit.

- C. Remove wire from Terminal '1' and connect to Terminal 'PCOM'.
- D. Remove wire from Terminal '2' and connect to Terminal 'PNO'.
- E. Remove wire from Terminal '4' and connect to Terminal 'BNC'.
- F. Remove wire from Terminal '5' and connect to Terminal 'BCOM'.
- G. Remove wire from Terminal '6' and connect to Terminal 'BNO'.

Snap Switches (Series 150S and 157S)

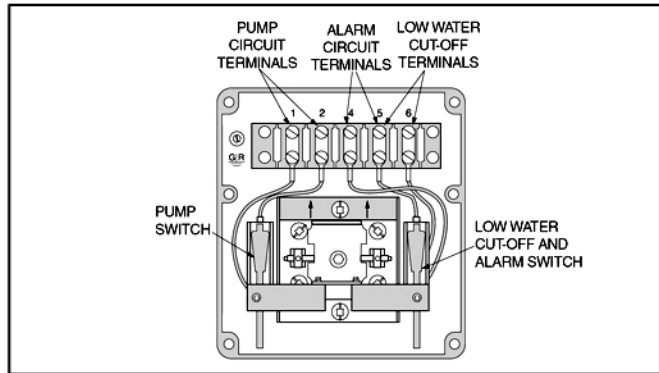

Mercury Switches (Series 150 and 157)

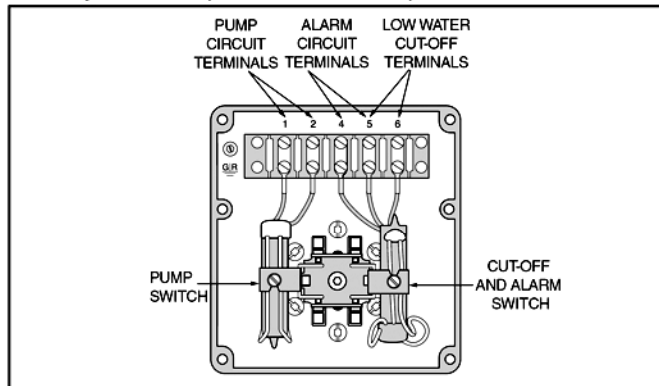

Electronic Relays (Series 150E and 157E)

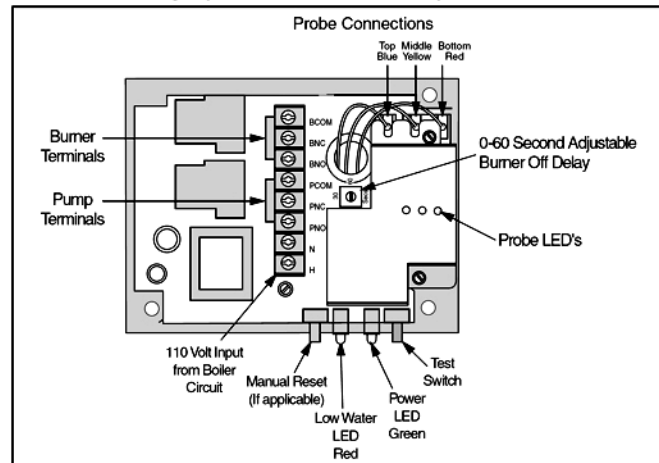

McDonnell-Miller 150E and 157E Boiler Controls

The Future Has Arrived! No more mechanical operation!

ESPECIALLY GREAT FOR BOILERS WITH RAPIDLY FLUCTUATING WATER LINES — FEATURES:

- Primary and secondary low water cut-off protection and pump control for commercial and industrial steam boilers
- Great for applications with rapidly shifting water levels
- Ideal for vertical tubeless, water tube, process and smaller fire tube boilers
- Conductance probe level detection
- Maintains differentials throughout pressure range
- Internal diagnostics to monitor operation
- Field adjustable burner-off time delay that prevents nuisance shutdowns by compensating for shifting water lines
- Maximum pressure – 150 psi.

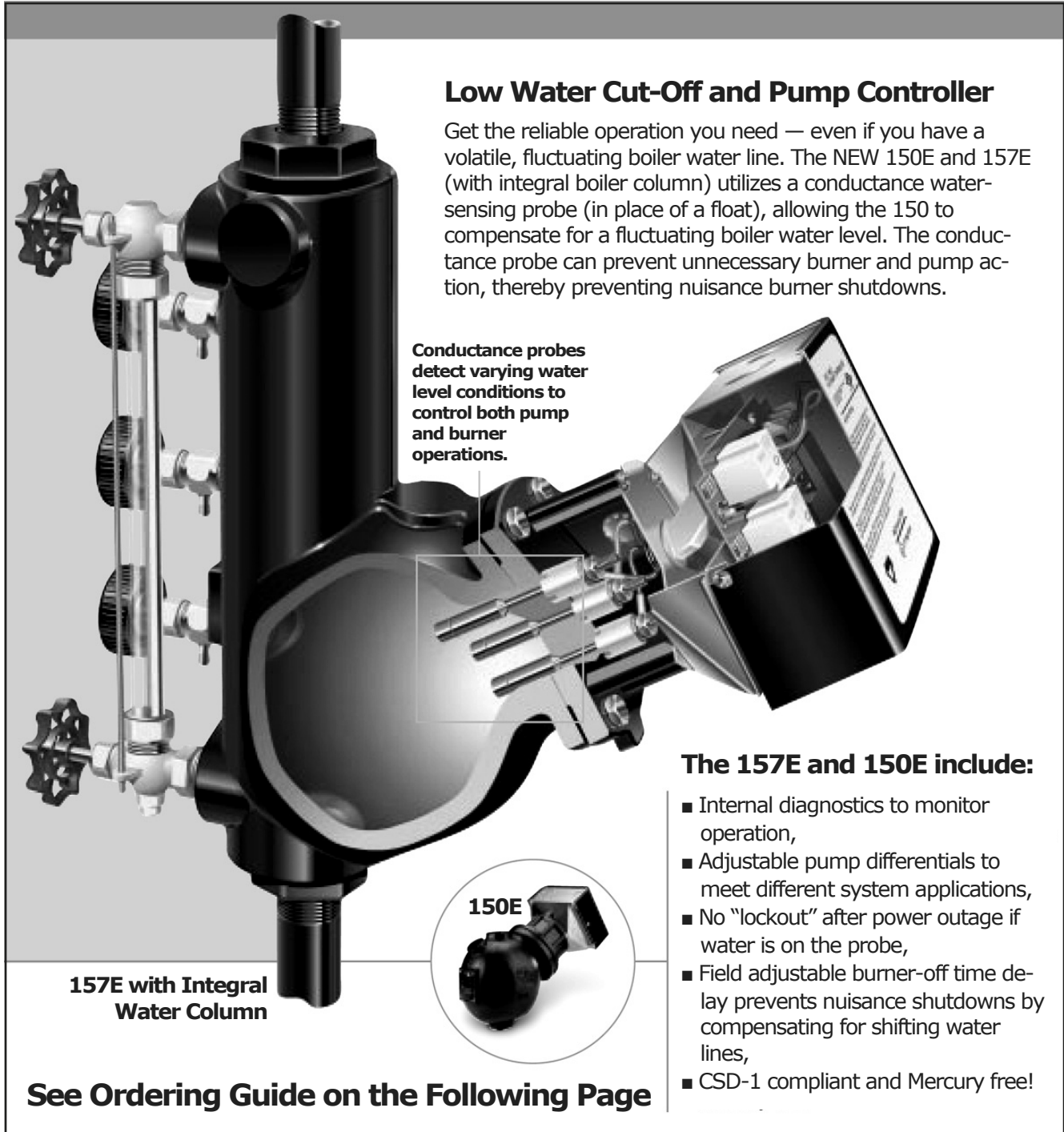

Low Water Cut-Off and Pump Controller

Get the reliable operation you need — even if you have a volatile, fluctuating boiler water line. The NEW 150E and 157E (with integral boiler column) utilizes a conductance water-sensing probe (in place of a float), allowing the 150 to compensate for a fluctuating boiler water level. The conductance probe can prevent unnecessary burner and pump action, thereby preventing nuisance burner shutdowns.

Conductance probes detect varying water level conditions to control both pump and burner operations.

The 157E and 150E include:

- Internal diagnostics to monitor operation,
- Adjustable pump differentials to meet different system applications,
- No “lockout” after power outage if water is on the probe,
- Field adjustable burner-off time delay prevents nuisance shutdowns by compensating for shifting water lines,
- CSD-1 compliant and Mercury free!

157E with Integral Water Column

150E

See Ordering Guide on the Following Page

Series 150E & 157E Electric Cut-Off/Pump Control

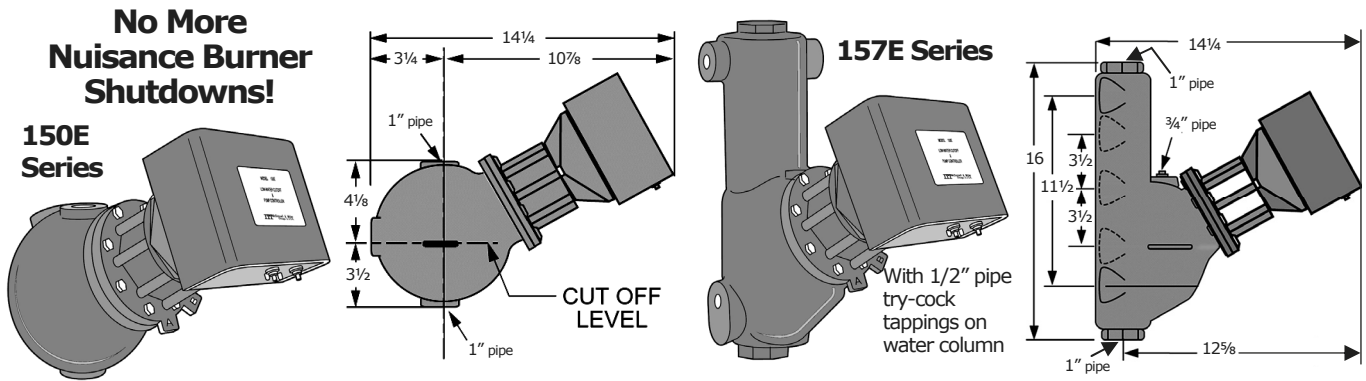

Complete Model 150E and 157E and Head Mechanisms			
Model No.	Description	Complete Order No.	Head Assembly
150E	Cut-Off/Pump Controller—Snap, #171600	MH1091A	MI1141A
150E-M	150E With manual reset, #171610	MH1091B	MI1141B
157E	150E with built-in water column, #171620	MH1091C	MI1141A
157E-M	157E with manual reset, #171630	MH1091D	MI1141B

No more nuisance burner shutdowns due to volatile, fluctuating boiler water lines!

If you have one of those boilers where the water line fluctuates like a roller coaster, your problems are over . . .

Utilizing conductance water sensing probes (in place of float operation) the *NEW* Model 150E detects varying water level conditions to efficiently control both pump and burner operation.

Prevent nuisance burner shutdowns and get efficient boiler operation.

Select from automatic or manual re-set.

Electrical Rating and Switch Ratings

Supply Voltage	Probe Voltage	Full load (Amps) NO (NC), VAC	Locked Rotor (Amps) NO (NC), VAC	Pilot Duty (VA) NO (NC), VAC	Motor (HP) NO (NC), VAC
120 VAC	5 VAC	16 (5.8), 120	96 (34.8), 120	470 (290), 120	1 (1/4), 120
50/60 Hz	Maximum	8 (4.9), 240	48 (17.4), 240	470 (290), 120	2 (1/2), 240

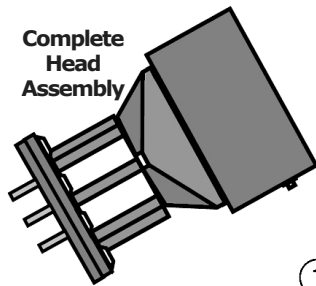

150E and 157E Repair Parts

Not many parts to deal with here! Order the flange probe assembly (1), the control unit (2) or the complete head assembly.

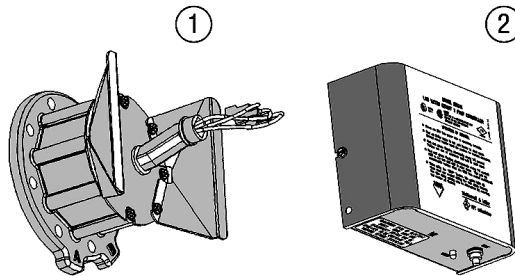

Applications & Features for the 150E and 157E:

- Primary or secondary pump controller/low water fuel cut-off for steam boilers
- Motorized valve controller
- Low water and high water cut-off
- Dual pump control
- Alarm actuator

Burner Relay Time Delay

There is a field-adjustable time delay (DOB) to prevent nuisance burner shut-down. The number of seconds water needs to be off the bottom probe before the burner relay is deactivated can be field adjusted between 0 and 60 seconds.

Redundant Low Water Cut-Off

When the boiler water drops below the middle probe, a 3 minute timing circuit will be activated. If water does not return to the middle probe within three minutes, the burner relay will deactivate. The Red LED will flash once every second if this condition occurs.

- Automatic Reset units will automatically reset when the water level is restored to the middle probe.
- The reset button on Manual Reset units will have to be pressed after water is restored to the middle probe.

Redundant Pump Off

The pump relay will be activated after water drops below the middle probe. If the water level is not restored to the top probe within 3 minutes the pump relay will be deactivated. After the pump relay is deactivated, normal operation is resumed. Water must again drop off the middle probe to activate the pump relay. There is no LED signal for this occurrence.

Repair Parts for 150E and 157E

Item	Description	Order No.
1	Flange and Probe Assembly	MI1140F
2	Control Unit	MI1140E
3	Head-to-Bowl Gasket	MI1140
Manual Re-set Complete Head Assembly		MI1141A
Automatic Re-set Complete Head Assembly		MI1141B

McDonnell-Miller 551-S Make-Up Water Feeder

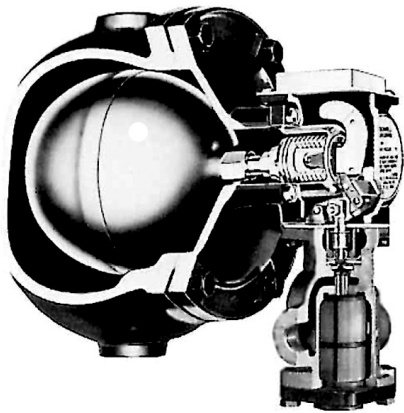

Features

The **551-S float-operated feeder** is designed for use where heated water is added to steam separators, receivers, tanks or other vessels.

- The float chamber is sealed from the valve assembly through the use of two Monel bellows.
- Construction provides an air gap between the receiver tank or vessel and the available water supply.
- Mounts directly onto the receiver
- Maximum water supply pressure @ 150 psi
- Maximum water supply pressure @ 25 psi

Complete 551-S		
Model	Description	Order No.
551-S	Make-up water feeder	MH1113A

Repair Parts for 551 Series		
Part No.	Description	Order No.
1	Float & Gasket	MI1275A
2	Gasket	MI1180
3	Bellows bracket assembly	MI1293D
4	Gasket	MI1050
5	Complete Valve with Strainer	MI1373C
6	O-Ring for strainer	MI1385
7	Strainer Basket, includes #6	MI1345
8	Cartridge & Strainer kit	MI1282
551-S-HD	Replacement Head Assembly	MI1152

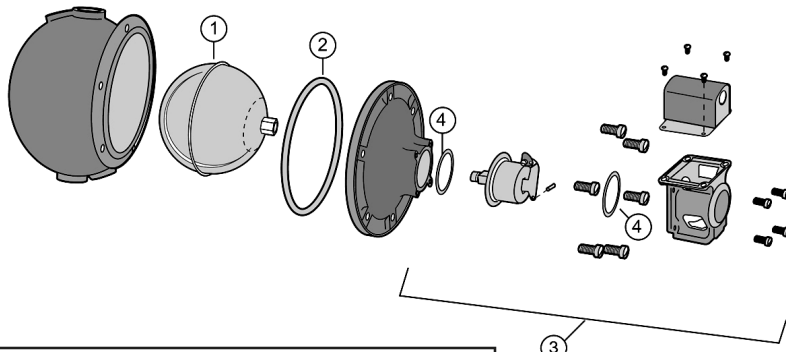
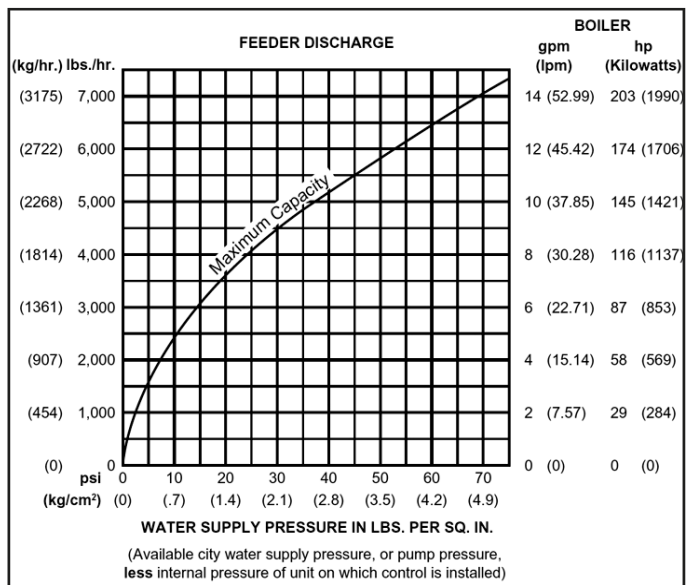

REPAIR NOTE:

One time float and bellows replacement is required when replacing bellows or float assemblies with date codes before April 1999 and after February 2005.

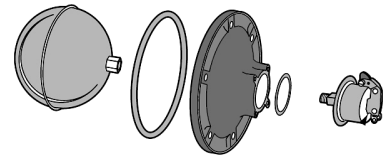

**April 1999 or Before
February 2005 and After**

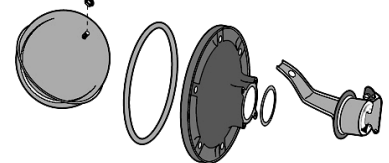

**May 1999 through
January 2005**

HEAD ASSEMBLY

The easy way to repair your **551-S** make-up water feeder. All new components pre-assembled for easy installation!

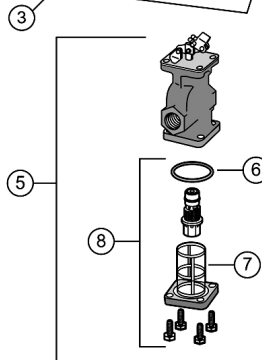

McDonnell-Miller 247 Feeder & Feeder Cut-Off

No. 247-2 Boiler Water Feeder & Feeder Cut-Off

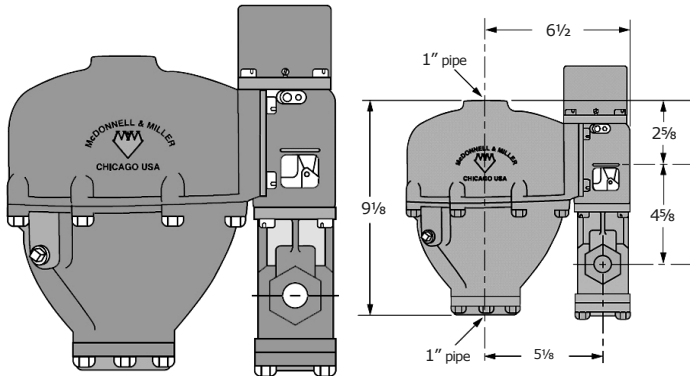

No. 2 Automatic and 2M Manual Switch

Supplied as standard equipment on the 247-2 (**No. 2** automatic reset switch) and the 247-2M (**No. 2M** manual reset switch). Can also be purchased separately to add a burner cut-off function to a 247 water feeder. Has high voltage terminals for low water cut-off and low water alarm.

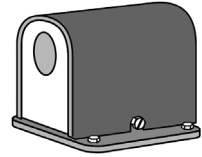

Electrical Ratings, Ampere ratings

Motor Duty	120VAC	240VAC
Full Load	10.2	5.1
Locked rotor	61.2	30.6
Pilot duty service: 345VA, 120 and 240VAC		

Complete 247 Series

Model	Description	Order No.
247	Water feeder less switch	MH1110
247-2	Water feeder with automatic No. 2 switch	MH1111
247-2M	Water feeder with manual reset 2M switch	MH1111A

Features of the Series 247

- For steam and hot water boilers with a cold water feed.
- Continual maintenance of minimum safe water level.
- No. 2 (automatic reset) and 2M switch (manual rest) add the low water cut-off function to the 247.
- Maximum operating pressure, 30 psi;
- Max. water supply pressure, 150 psi

Capacities for 247

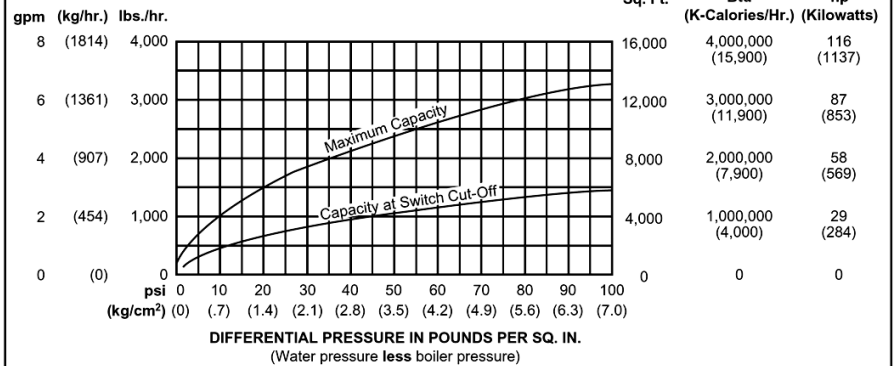

Repair Parts for 247 Series

Part No.	Description	Order No.
1	Cartridge and strainer kit	MI1262
2	Valve, cartridge and strainer kit	MI1260
3	O-Ring	MI1385
4	Strainer Assembly	MI1345
5	Bellows bracket assembly	MI1255
6	Gaskets (2) for bracket assembly	MI1050
7	Cam assembly	MI1175
8	No. 2 Automatic Re-Set Switch	MI1005
9	No. 2M Manual Re-Set Switch	MI1006
14	Float (includes gasket #15)	MI1235
15	Gasket for Bowl	MI1045
16	Complete blow-down valve	MI1015
17	Blow-down valve gasket	MI1060

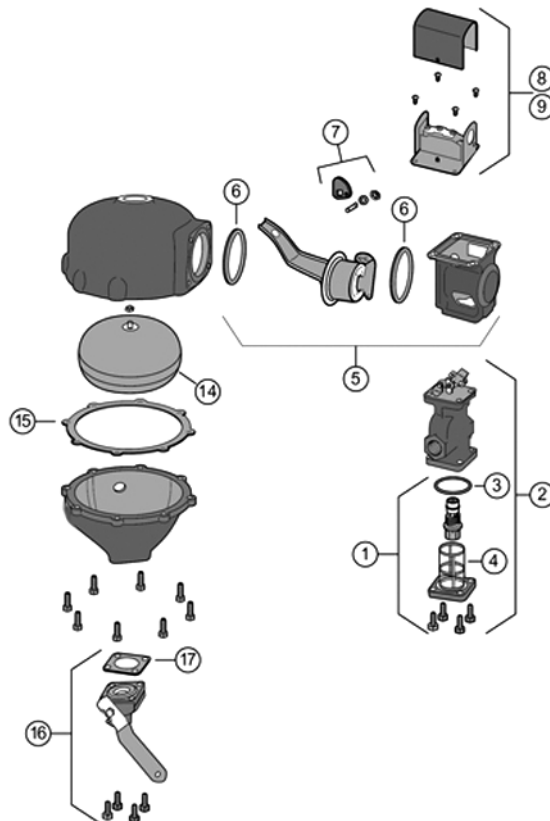

McDonnell-Miller 750 Low-Water Cut-Off Controls

Model 750 Electronic Low Water Cut-Off
Can be used with Remote Sensors on following page

FEATURES:

- For commercial applications as a primary or secondary control on **hot water boilers** and Secondary control (manual reset models only) on **steam boilers**.
- Manual reset models must be "reset" manually before the burner will fire again. Do not use manual reset models with automatic water feeders.
- 750P control units come with a built-in probe
- Probe sensitivity: 20,000 ohms
- Control power consumption: 3VA (maximum)
- **Remote sensors and probes ordered separately** — Please see the following page to order
- LED indicating lights for power and low water condition.
- Dual rated voltage: 120/240
- Test switch on all models. ■ Max. water pressure, 160 psi

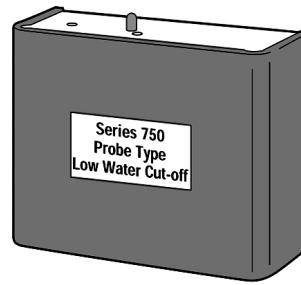

750 Control
Control box used with the RS Sensors and Probes found on the following page.

750P Control

With built-in Probes.
Not for use with remote sensors.

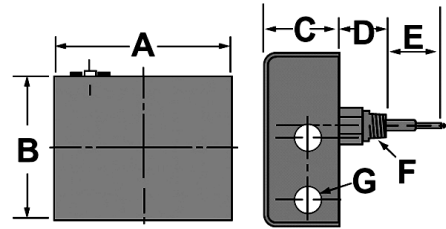

Dimensions of 750 Series (inches)

A	B	C	D		E		F	G
			Std.	U	Std.	U		
6 ³ / ₈	5 ¹ / ₈	2 ¹ / ₂	1 ¹ / ₂	3	2 ¹ / ₈	1 ¹ / ₂	3 ⁴ / ₄	3 ⁴ / ₄

Voltage	Full Load	Locked Rotor	Pilot Duty
120VAC	7.2	43.2	125VA at 120 or 240VAC
240VAC	3.6	21.6	

750 Electronic Low Water Cut-Offs

Model	Description	Order No.
750-T-120	750 only, with Automatic reset <i>Remote sensors and probes, next page</i>	MH1114C
750-MT-120	750 only, with Manual reset <i>Remote sensors and probes, next page</i>	MH1114D
750P-MT-120	750P control unit with PA800 probe, Manual reset	MH1114E
750P-MT-U-120	750P control unit with PA-800-U probe, Manual reset	MH1114F

750 Replacement Parts

Part No.	Description	Order No.
PA-800	Probe for 750T and MT-120	MI1496
PA-800-U	Probe for 750P-MT-U-120	MI1497
MPG-106F	Manual Reset Switch	MI1535B

Automatic Reset Models

Whenever water is below the level of the probe, the control will go into a low water condition. When the water level has been restored, the control will automatically return to a run condition.

Manual Reset Models

If a low water condition occurs (water off probe), the manual reset button must be pressed once the water level is restored to a level above the probe.

CSD-1 Code Compliance

On Manual Reset units, if the control is in a low water condition (water off probe) when there is an interruption of power, the control will remain in a low water condition when power is restored. The reset button will need to be pressed when the water level is restored to a level above the probe. Do not use manual reset models with an automatic water feeder!

Troubleshooting

If control fails to operate as required, perform the following diagnostic checks:

1. Check to be sure that the water level in the boiler is at or above the level of the probe.
2. Re-check all wiring to ensure proper connections as specified in boiler manufacturer's wiring diagrams or these instructions.
3. Check to ensure that Teflon® tape has not been used on the threaded connection of the electrode to the boiler.
4. Re-check the electrical ground connection for the remote sensor and control unit.
5. Check the quality of the boiler water to ensure adequate conductance.

PA-800

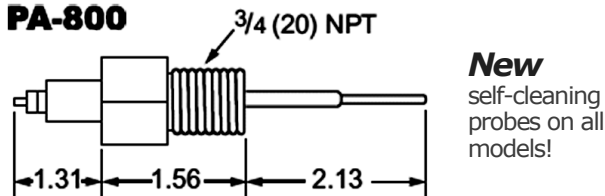

New
self-cleaning probes on all models!

PA-800-U Extended Barrel

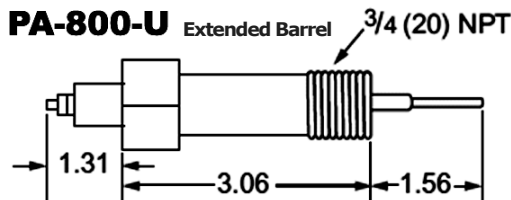

McDonnell-Miller Sensors, Probes & Repair Parts

Series RS Sensors

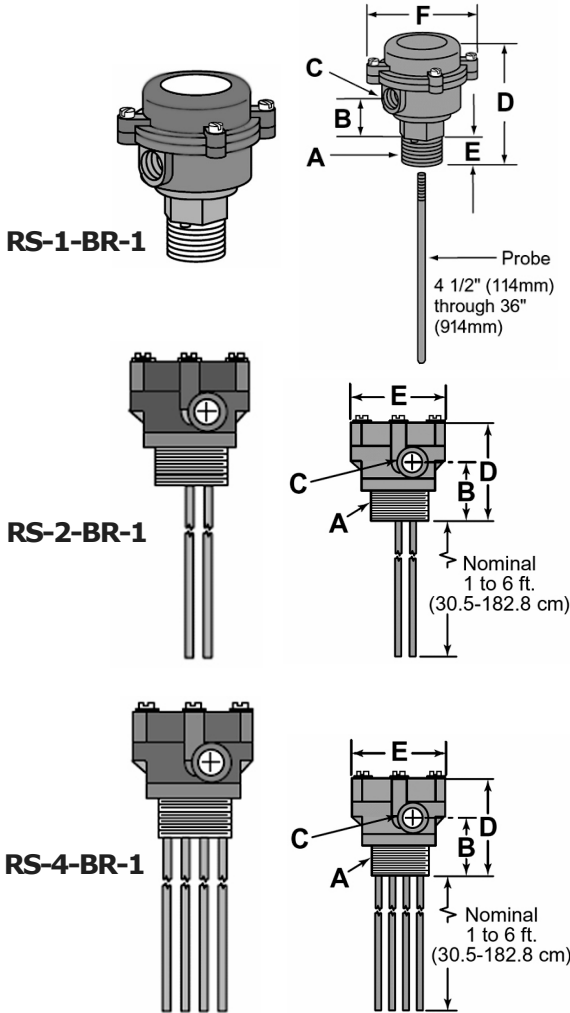

See sensing probes below. Order separately.

Features

RS Sensors are used with the 750 control box shown on the previous page. Used for more sophisticated multi-level control in tanks, boilers and hydronic systems.

■ These remote sensors thread into the top of a boiler, tank or equalizing pipe.

■ Select from sensors that control 1, 2, 3, 4 or 5 probes of varying lengths that can easily be cut to the desired set point.

■ The sensing probes are purchased separately and available in lengths from 12" to 72" (in 12" increments).

■ Maximum temperature, 406° F.

■ All models are NEMA 4X Enclosure, except the RS-1-HP @ NEMA 1 Enclosure

■ Maximum pressure @ 250 psi, except RS-1-LP to 15 psig

RS Remote Sensors used with 750 control box

Model No.	Description	Order No.
RS-1-HP	3/8" pipe size, high pressure, 1 probe	RS1HP
RS-1-LP	3/4" pipe size, low pressure, 1 probe	MI1551
RS-1-BR-1	1" pipe connection, for 1 probe	MI1550
RS-2-BR-1	2" pipe connection, for 2 probes	MI1555
RS-3-BR-1	2" pipe connection, for 3 probes	MI1560
RS-4-BR-1	2 1/2" pipe connection, for 4 probes	MI1565
RS-5-BR-1	2 1/2" pipe connection, for 5 probes	MI1566

Repair Parts for Remote Sensor see diagram below

Item No.	Parts Description	Order No.
1	Cover gasket	MI1194D
2	Electrode, long	MI1176B
3	Electrode, short (for RS-1-LP only)	MI1496

Remote Sensor Dimensions (inches)	A Pipe Size	B	C	D	E	F
Sensor with 1 Probe	1	1 3/4	1/2 pipe	4 1/2	4 1/4	3 1/4
Sensor with 2 or 3 Probes	2	2 3/8	1/2 pipe	3 7/8	4	—
Sensor with 4 or 5 Probes	2 1/2	2 1/2	1/2 pipe	4	4	—



Teflon® Coating

Sensing Probes Trim to desired length		
Model	Description	Order No.
Spacer S-4	Use when joining probes over 36" for lengths up to 120"	MI1495
Probes, Teflon coated: protects false signals that can trigger nuisance shutdowns. Also used as grounding rods.		
P-1/3-SS	4 1/2" Teflon probe	MI1504
P-1-SS	12" Teflon probe	MI1500
P-2-SS	24" Teflon probe	MI1505
P-3-SS	36" Teflon probe	MI1510
P-4-SS	48" Teflon probe	MI1515
P-5-SS	60" Teflon probe	MI1520
P-6-SS	72" Teflon probe	MI1521

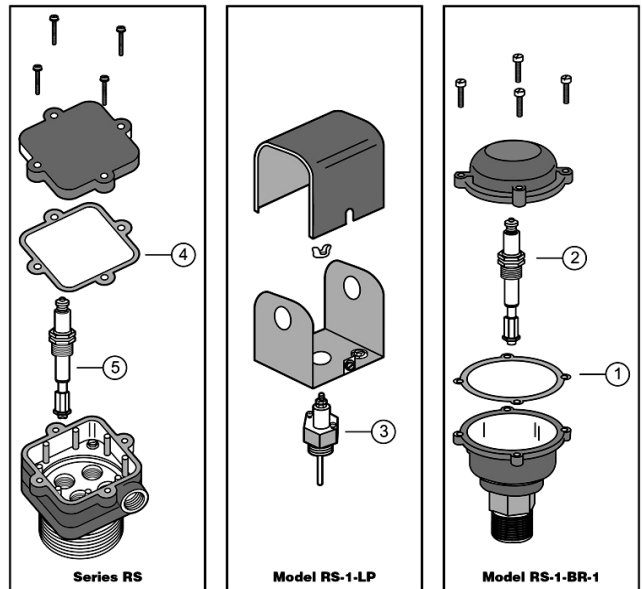

McDonnell-Miller 750B Low-Water Cut-Off & Chamber

Model 750B electronic low water cut-off with Sensor Chamber and Probes

FEATURES:

- Low water cut-off for steam & hot water boilers: pump on, pump off or high level alarm. Max. water pressure, 250 psi
- 24 and 120 volt models
- Automatic or manual reset function on each board
- Do not use **manual reset** with Automatic Water Feeder!



750B Module

The Series 750B controllers provide reliable control of burner circuits, motor starters, electric valves or pumps in boilers, cooling towers or other liquid level applications. Designed for use with the 750-C chamber, Series RS sensors or other remote probes to create a complete operating system.

Switch Contact Electrical Ratings			
Model Voltage	Voltage	Full Load	Locked Rotor
24 Volt AC	24 VAC	—	—
120 Volt AC	120 or 240 VAC	7.2 or 3.75	43.2 or 21.6

HOW TO ORDER THE 750B models:

1. Order panel mount or plug-in module 750B control unit.
2. Order appropriate chamber (below) based on the number of levels to be sensed.

750B Conductance Actuated Level Controls		
Model	Description	Order No.
PANEL MOUNT Design		
750B-L-24-C-03	Low water cut-off (LWCO), 24V	MI1540
750B-L-120-C-03	Low water cut-off, 120V	MI1540A
750B-P-120-CI	Pump controller	MI1540B
750B-DLP-120-CI-03	Dual LWCO & pump controller	MI1535
You must order this enclosure for the MI1535 above		MI1535A
750B-LP-120-CI-03	LWCO and pump controller	MI1540C
PLUG-IN MODULE Design ■ Order Sockets below		
750BM-L-24-C-03	Low water cut-off	MI1541
750BM-L-120-C-0	Low water cut-off	MI1541A
750BM-P-120-CI	Pump controller	MI1541B
PLUG-IN MODULE SOCKETS		
750BM-8PS	Eight-pin socket	MI1542
750BM-11PS	Eleven-pin socket	MI1542A
Adaptor-750	PCB adaptor plate kit	MI1545

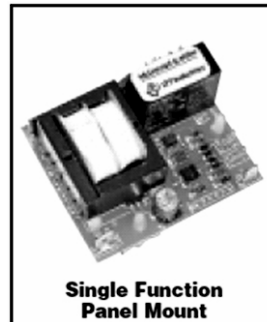

Single Function Panel Mount

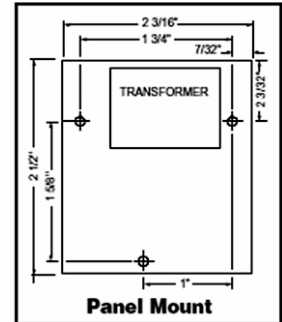

Panel Mount

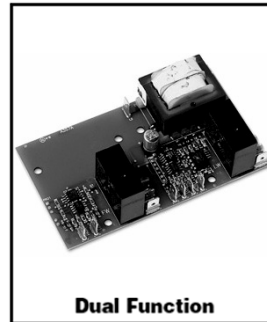

Dual Function

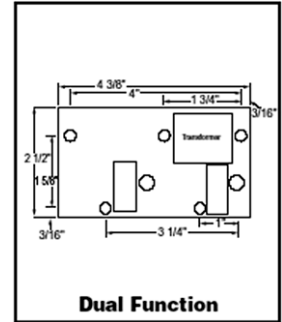

Dual Function

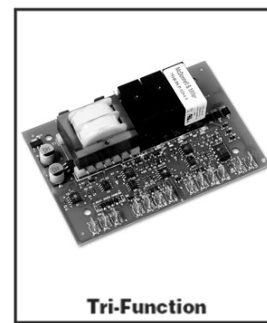

Tri-Function

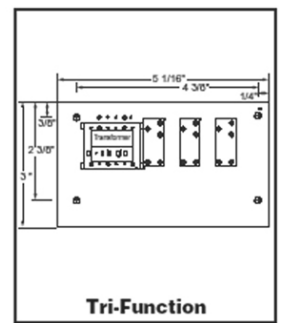

Tri-Function

Remote Chamber for 750B Series

Designed for use with the Series 750B remote mount control module. Makes a complete system for level control in a boiler or other vessel.

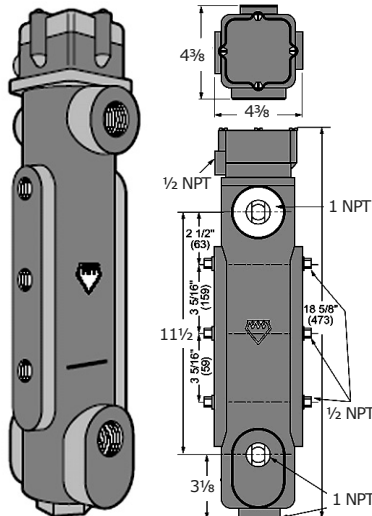

Cast Iron Chamber with Probes for 750B remote mount control module

Choose the 750B-C3 with three sensing probes, or the 750B-C4 with four probes. Maximum steam pressure, 250 psi. Replacement Electrodes below.

Chambers for 750B control modules				
Model No.	Description	Order No.	High Pressure Electrode	Low Pressure Electrode
750-C-3	Remote chamber, 3 probes	MI1543	MI1544A	MI1544
750-C-4	Remote chamber, 4 probes	MI1543A		

McDonnell-Miller Obsolete LPC-2000 Level Control

Series LPC-2000 Control Units

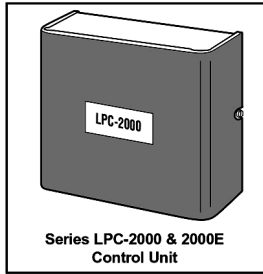

NEMA 1

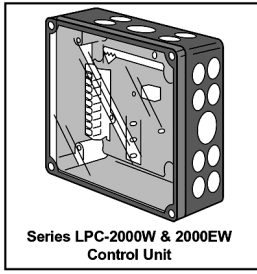

NEMA 4X

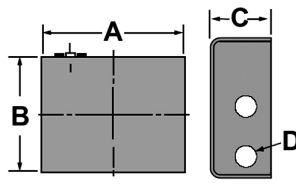

LPC-2000 dimensions

A	B	C	D
6-3/8	5-1/8	2-9/16	7/8

Features of the obsolete LPC-2000 Replaced by the 750 Series

- Level sensing and pump control of cooling towers, tanks, water fountains, condensate units and more!
- Digital technology utilizing a micro-controller.
- Field selectable control unit allows for single or multi-level sensing.
- Utilize 1 to 3 operating modes:
 - Low level alarm
 - High level alarm
 - Pump on/off
- Time delay feature prevents disturbances and false signals from water level surges.
- Select from NEMA 1 or NEMA 4X models.
- Ambient temperature to 120° F.
- Order sensors and probes separately.

Electrical Ratings

Model	Supply Voltage	Probe Voltage	Pump Switch (Amperes)		Load Switching	
			Full Load	Locked Rotor	Alarms	Pump
LPC 2000	120 VAC	12 VAC	16	96	360 VA at 120 VAC	1HP at 120 VAC
LPC 2000W	50/60 Hz	12 VAC				
LPC 2000E	220 VAC	12 VAC	8	48	360 VA at 120 VAC	1HP at 120 VAC
LPC 2000EW	50/60 Hz	12 VAC				

LPC-2000 Liquid Level Control Units

Model No.	Control Volts	Probe Volts	Description	Order No.
LPC-2000	120	12	Standard LPC control unit, NEMA 1 enclosure	OBSOLETE See the 750 Series
LPC-2000W	120	12	LPC with NEMA 4X enclosure	
LPC-2000E	220	12	LPC with 220 volt input, NEMA 1 enclosure	
LPC-2000EW	220	12	LPC with NEMA 4X and 220 volt	

Remote Sensors and Sensing Probes Available

Order Below

Remote Sensors for LPC-2000 & 750

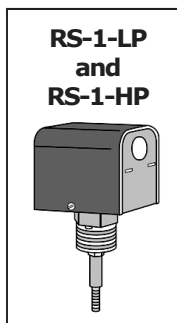
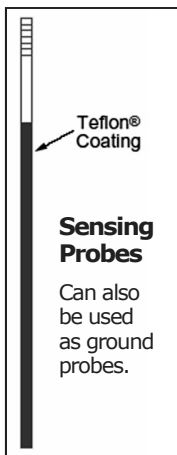
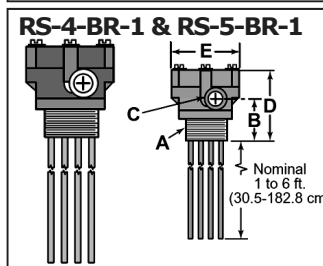
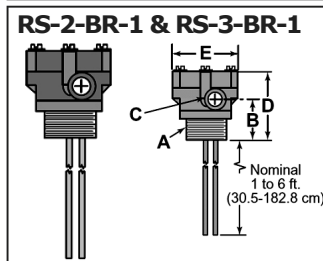
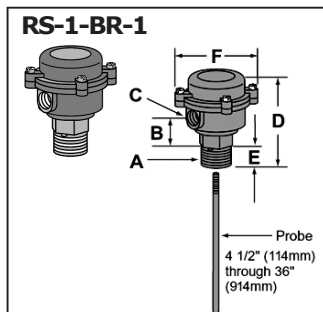

RS Remote Sensors (order sensing probes below)

Model No.	Description	Order No.
RS-1-LP	3/4" pipe size, steam rated to 15 psi, 1 probe	MI1551
RS-1-BR-1	1" pipe size, 250 psi, for 1 probe	MI1550
RS-2-BR-1	2" pipe size, 250 psi, for 2 probes	MI1555
RS-3-BR-1	2" pipe size, 250 psi, for 3 probes	MI1560
RS-4-BR-1	2 1/2" pipe size, 250 psi, for 4 probes	MI1565
RS-5-BR-1	2 1/2" pipe size, 250 psi, for 5 probes	MI1566

Repair Parts for Remote Sensors

Item No.	Parts Description	Order No.
1	Cover gasket	MI1194D
2	Electrode, long	MI1176B
3	Electrode, short (for RS-1-LP only)	MI1496

Sensing Probes (trim to desired length)

P-1/3-SS	4 1/2" Teflon probe	MI1504
P-1-SS	12" Teflon probe	MI1500
P-2-SS	24" Teflon probe	MI1505
P-3-SS	36" Teflon probe	MI1510
P-4-SS	48" Teflon probe	MI1515
P-5-SS	60" Teflon probe	MI1520
P-6-SS	72" Teflon probe	MI1521
Spacer S-4	Use when joining probes over 36" for lengths up to 120"	MI1495

McDonnell-Miller PS-801 & PS-802 Low Water Cut-Offs

PS-800 Features:

- Electronic operation: For residential & commercial low-pressure steam boilers (up to 15 psig).
- Self-cleaning probes prevent lime build-up for 5 years!
- 24 volt (Model PS-802) or 120 volt (Model PS-801)AC.
- User friendly diagnostic:
 - Red LED — Low water and shorted probe
 - Green LED — Power and testing function
- Probe sensitivity to 7,000 ohms
- No lock-out with loss of power if probe is in water
- 15-second Delay on Make feature
- 10-second Delay on Break feature
- No blow-down of control needed when directly mounted into the boiler tappings
- Test button is standard on all models
- Options available include:
 - Manual reset (Do not use with automatic water feeder)
 - Extended barrel, remote and short probe models
- Power consumption at 1.7 VA
- Provisions to add alarm or automatic water feeder. Do not use Manual Reset models with an automatic water feeder.
- Maximum steam pressure, 15 psi
- Maximum water temperature, 250° F.
- Maximum ambient temperature, 120° F.

PS-800 designed for low pressure Steam Boilers

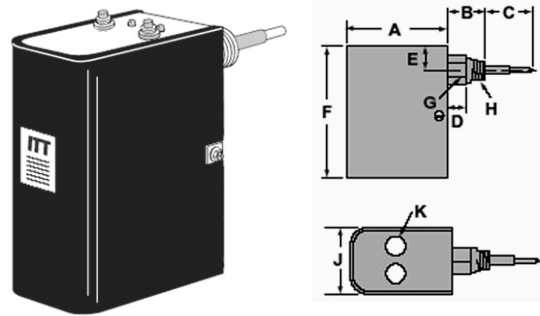

Now with Self-Cleaning Probes!

Dimensions of PS-800 Series (inches)

A	B	C	D	E	F	G	H	J	K
4¼	See probes below	3/4	13/16	5-13/16	1¾	See probes below	27/8	7/8	

Electrical Ratings for PS-800 series, Ampere ratings			
Voltage	Full Load	Locked Rotor	Pilot Duty
24VAC	—	—	50VA @ 24VAC
120VAC or 240VAC	7.5 or 3.75	43.2 or 21.6	125VA @ 120 or 240V

PS-801 and PS-802 Low Water Cut-Offs

Model No.	Description	Order No.
120 Volt Models		
PS-801-120	Automatic reset low water cut-off	MH1172
PS-801-M-120	Manual reset low water cut-off	MH1172A
PS-801-U-120	Automatic reset and extended barrel	MH1172B
PS-801-M-U-120	Manual reset and extended barrel	MH1172C
24 Volt Models		
PS-802-24	Automatic reset low water cut-off	MH1173
PS-802-M-24	Manual reset low water cut-off	MH1173A
PS-802-U-24	Automatic reset and extended barrel	MH1173B
PS-802-M-U-24	Manual reset and extended barrel	MH1173D
PS-802-RX2-24	Low water cut-off with remote sensor	MH1173C
Replacement Electrodes		
PA-800	Standard barrel electrode	MI1496
PA-800-U	Extended barrel electrode	MI1497
PA-800-RX2	Electrode for remote sensor for PS-802-RX2-24	MI1498

Automatic Reset Models — Whenever water is below the level of the probe, the control will go into a low water condition. When the water level has been restored, the control will automatically return to a run condition.

Manual Reset Models — If a low water condition occurs (water off probe), the manual reset button must be manually pressed once the water level is restored to a level above the probe.

Do not use **Manual Reset** models with an automatic water feeder!

Replacement Electrodes

■ Standard PA-800 Electrode

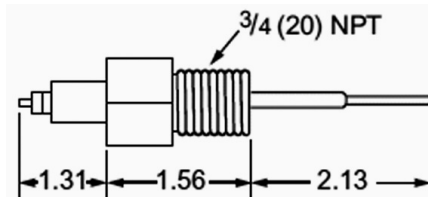

■ Extended Barrel PA-800-U Electrode

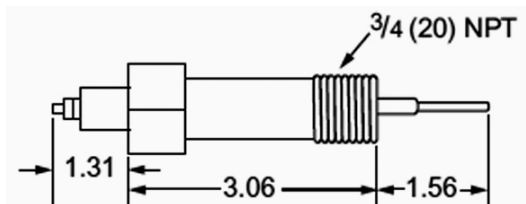

■ Extended Barrel PA-800-RX2 Electrode

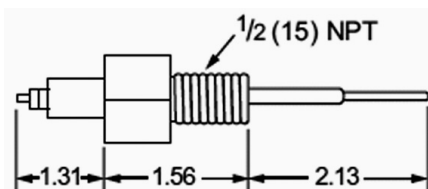

All dimensions above in inches.

McDonnell-Miller PS-851 & PS-852 Low Water Cut-Offs

PS-851 and PS-852 Features:

- Electronic operation: For residential & commercial Hot Water boilers.
- Self-cleaning probes prevent lime build-up for 5 years!
- 24 volt (Model PS-852) or 120 volt (Model PS-851)AC.
- User friendly diagnostic:
 - Red LED — Low water and shorted probe
 - Green LED — Power and testing function
- Probe sensitivity to 7,000 ohms
- No lock-out with loss of power if probe is in water
- No blow-down of control needed when directly mounted into the boiler tapings. Provisions to add alarm
- Test button is standard on all models
- Options available include:
 - Manual reset (Do not use with automatic water feeders).
 - Extended barrel, remote and short probe models
- Standard PS model, 3/4" pipe connection. The PS models with "RX" in the model number have a 1/2" pipe connection.
- Provisions to add alarm
- Maximum water pressure, 160 psi; Maximum water temperature, 250° F.; Max ambient temperature, 120° F.

PS-850 series electronic low water cut-offs are designed specifically for Hot Water Boilers.

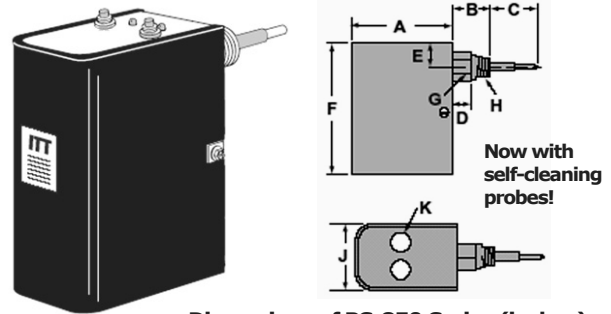

Dimensions of PS-850 Series (inches)

A	B	C	D	E	F	G	H	J	K
4/4	See probes	3/4	13/16	5-13/16	1 3/8	See probes	2 7/8	7/8	

Electrical Ratings for PS-850 series, Ampere ratings

Model	Voltage	Full Load	Locked Rotor	Pilot Duty
24 VAC	24VAC	—	—	50VA @ 24VAC
120 VAC	120 or 240	7.5 or 3.75	43.2 or 21.6	125V @120/240

PS-851 and PS-852 Low Water Cut-Offs

Model No.	Description	Order No.
120 Volt Models		
PS-851-120	Low water cut-off	MH1125A
PS-851-U-120	With extended barrel	MH1125B
PS-851-M-120	With manual reset	MH1129A
PS-851-M-U-120	Manual reset & extended barrel	MH1125C
PS-851-RX2-120	With remote probe	MH1125D
PS-851-M-RX2-120	Manual reset & remote probe	MH1125E
PS-851-SP-120	With short probe	MH1125F
PS-851-SP-M-120	Manual reset & short probe	MH1125G
24 Volt Models		
PS-852-24	Low water cut-off	MH1129B
PS-852-M-24	With manual reset	MH1129C
PS-852-SP-24	With short probe	MH1129D
PS-852-SP-M-24	Manual reset & short probe	MH1129E
Replacement Electrodes		
Item No.	Parts Description	Order No.
PA-800	Standard barrel electrode	MI1496
PA-800-U	Extended barrel electrode	MI1497
PA-800-RX2	Electrode for remote sensor for PS-802-RX2-24	MI1498
PA-RB-120	Electrode for models with "SP" in the model number	MI1499

Automatic Reset Models — After the burner is "cut-off" due to low water, and the water level has been restored, the control will automatically return to a run condition.

Manual Reset Models — If a low water condition occurs (water off probe), the manual reset button must be manually pressed once the water level is restored to a level above the probe.

- Do not use manual reset models with automatic water feeders!

Replacement Electrodes

■ Standard PA-800 Electrode

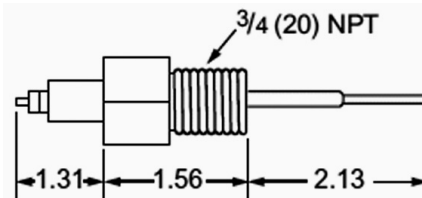

■ Extended Barrel PA-800-U Electrode

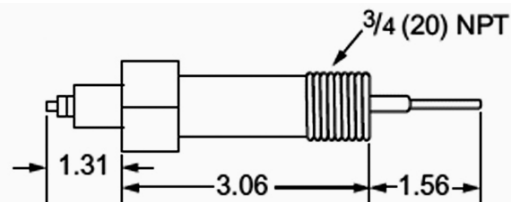

■ PA-800-RX2 Electrode

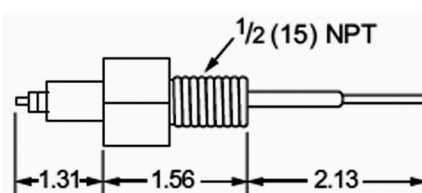

■ PA-RB-120 Electrode

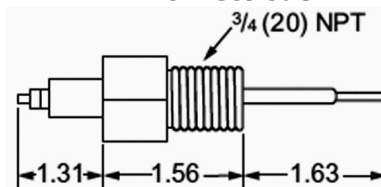

McDonnell-Miller RB-24, RB-120 & RB-122 Water Cut-Offs

RB-24 Series for Hot Water Boilers to 50 psi

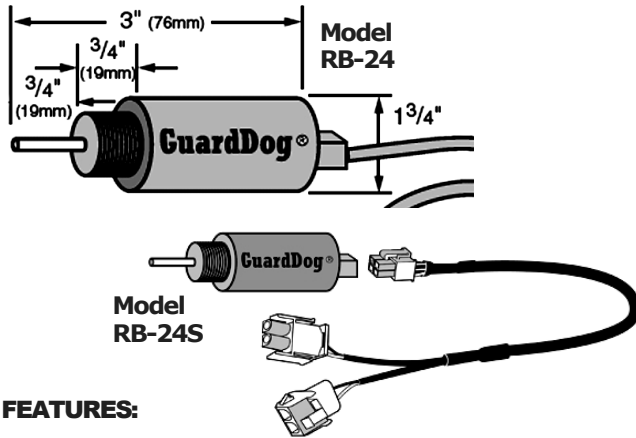

FEATURES:

- For residential hot water applications: Compact Size! Easy to install and wire with solid state operation.
- Automatic reset when water once again touches the probe after a low water condition.
- 15,000 ohms probe sensitivity. 3/4" pipe connection.
- No lock-out with loss of power if probe is in water
- Maximum water temperature: 250° F.
- Maximum water pressure: 50 psi.
- 24 volt with 2.5 VA power consumption and load switching at 2 amps at 24 VAC. Do not use on steam systems.

RB-24 Electronic Low Water Cut-Off		
Model No.	Description	Order No.
RB-24	Standard Low water cut-off, 24 volts	MH1174A
RB-24S	The RB-24S with wiring harness & plug connectors for burner controls made by United Technologies which have a plug connector on the chassis to connect 24volt transformer.	MH1174B

RB-122 for Hot Water Boilers to 160 psi

Now with self-cleaning probe to prevent lime build-up!

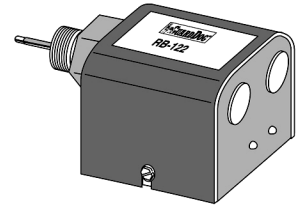

RB-122 Dimensions

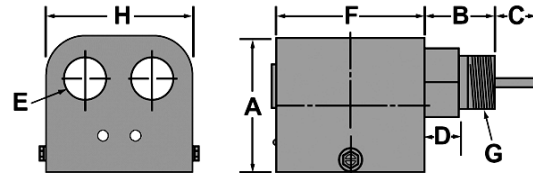

FEATURES:

- For residential and (where code permits) commercial hot water applications. Not for use with steam boilers.
- Self-cleaning probes prevent lime build-up for 5 years!
- Automatic reset when water once again touches the probe after a low water condition.
- 15,000 ohms probe sensitivity. 3/4" pipe connection.
- No lock-out with loss of power if probe is in water
- Maximum water temperature: 250° F. ; Maximum water pressure: 160 psi.; 120 volt with 15 VA power consumption and load switching at 5.8 amps at 120 VAC.

RB-122 Electronic Low Water Cut-Off		
Model No.	Description	Order No.
RB-122	Low water cut-off, 120 volts	MH1127A

Dimensions of RB-122

A	B	C	D	E	F	G	H
2-3/4	1-5/8	1-3/8	3/4	7/8	3-7/16	3/4 pipe	3-3/16

RB-120 Electro-Mechanical Low Water Cut-Off for Hot Water Boilers to 160 psi

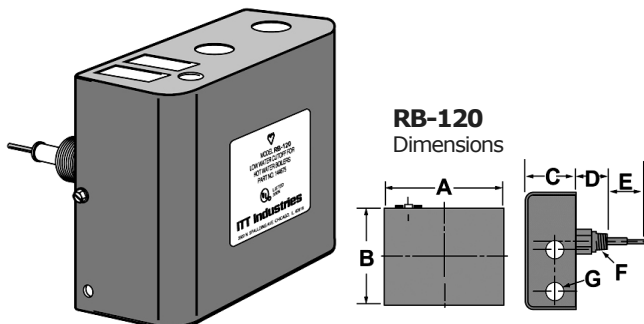

Dimensions

A	B	C	D	E	F	G
6-3/8	5-1/8	2-9/16	1-5/8	1-3/8	3/4 pipe	7/8

FEATURES:

- For residential and commercial (where codes allow) applications. Electro-mechanical operation.
- Automatic reset when water once again touches the probe after a low water condition.
- No blowdown required.
- 6,000 ohms probe sensitivity.
- No lock-out with loss of power if probe is in water
- Maximum water temperature: 250° F.
- Maximum water pressure: 50 psi.
- 120 volt with 15 VA power consumption and load switching at 5.8 amps at 120 VAC

RB-120 Electronic Low Water Cut-Off		
Model No.	Description	Order No.
RB-120	Low water cut-off, 120 volts	MH1127

McDonnell-Miller Electronic Water Feeders

WF Feeders for steam boilers to 15 psi

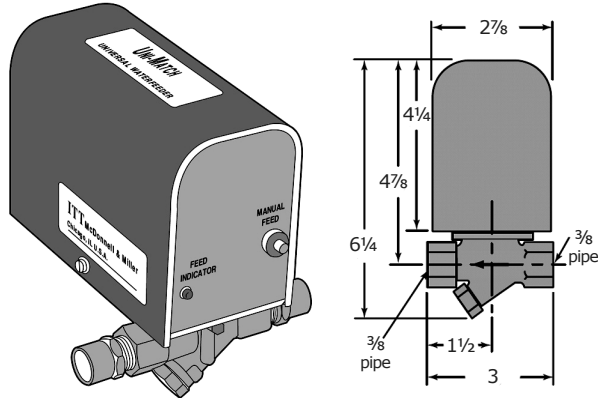

FEATURES:

- For low pressure steam boilers with a cold water feed
- Three-position slide switch allows the timing cycle to be matched to the low water cut-off
- Field adaptable field rate: 1, 2 or 4 gpm
- Electronic operation — select from 24 or 120 volt models — provides both consistent and accurate performance
- Can be used with mechanical or electronic low water cut-offs (**Not** for use with manual reset models)
- Manual feed button
- Includes 3/8" npt x 1/2" tubing adapters for quick installation with 1/2" copper tubing
- Easy to clean, replaceable strainer
- Maximum water pressure, 150 psi
- Maximum boiler pressure, 15 psi
- Maximum water temperature, 120° F
- Maximum ambient temperature, 100° F
- Maximum power consumption (during water feed)
 - 15 volts @ 24 volt operation
 - 20 volts @ 120 volt operation

WF-2 Electronic Low Water Cut-Off

Model No.	Description	Order No.
WF-2-U-24	Electric water feeder, 24 volt	MH1200
WF-2-U-120	Electric water feeder, 120 volt	MH1205
Repair Part	Strainer/Orifice kit (nut & strainer at unit base)	MI1375B

101A Feeders for steam boilers to 25 psi

Features:

- For steam boilers to 25 psi with a cold water feed
- Can be used with mechanical or electronic low water cut-offs (do **not** use with manual reset low water cut-offs)
- For Oil-fueled boilers: Order the standard 101A. Furnished with a 120VAC coil.
- For Gas-fueled boilers having 24 volt control circuits: Order the 101A-24V which includes the electrical transformer.
- Maximum boiler size: 5,000 square foot steam.
- Manual feed button to add water manually
- Maximum water supply pressure, 150 psi
- Maximum boiler pressure, 25 psi
- Maximum inlet water temperature, 120° F
- Maximum power consumption (during water feed)
 - 40 volts @ 24 or 120 volt operation

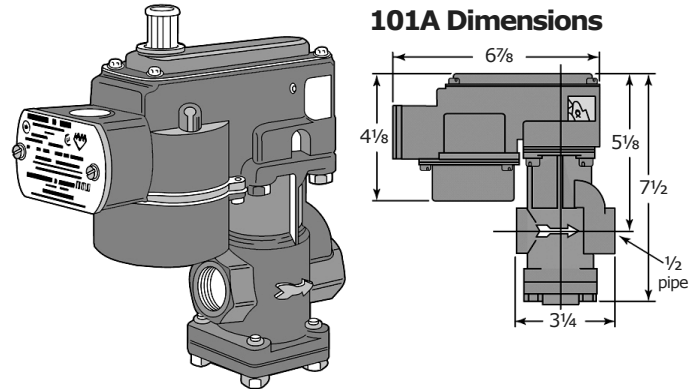

101A Dimensions

101A Repair Parts

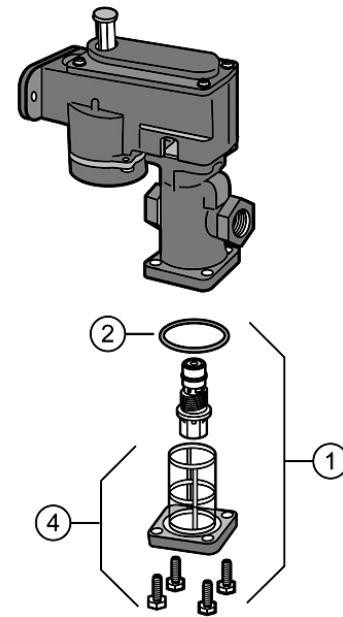

101A Electronic Low Water Cut-Off

Model No.	Description	Order No.
101A-24V	Electric water feeder, 24 volt	MH1090
101A	Electric water feeder, 120 volt	MH1085

Repair Parts for 101A

Item No.	Description	Order No.
1	Cartridge & strainer kit	MI1262
2	O-Ring	MI1385
3	24 volt transformer (Honeywell)	HN1195
4	Strainer with bolts & O-Ring	MI1345

McDonnell-Miller 764 Low Water Cut-Off

No. 764 Low Water Cut-Off

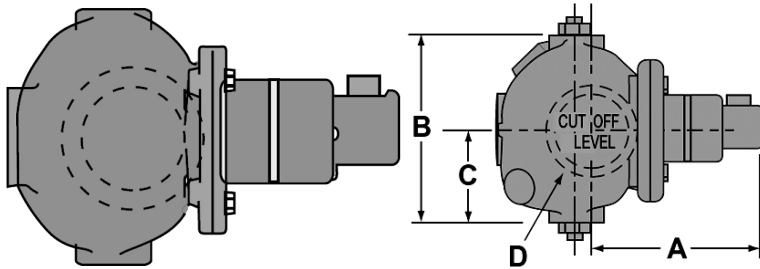

The No. 764 is designed with 2½" pipe side tapings (top and bottom) for installation with close nipples into the 2½" tapping available on some hot water boilers. The No. 764 can also be used on steam service. Similar to the No. 64 in construction and operation. Uses a No. 11 switch.

FEATURES:

- For steam and hot water boilers of any steaming capacity.
- Adjustable BX outlet for easy installation.
- Dual precision switches for dependable operation of cut-off, alarm or electric water feeder
- Maximum boiler pressure, 50 psi
- Automatic reset after low water condition

764 Low Water Cut-Off		
Model No.	Description	Order No.
764	Low water cut-off, 2½" tapping	MH1115

Dimensions for Model 764			
A	B	C	D
6⅞	6½	3⅛	2½

Electrical Ratings		
Ampere ratings for the cut-off circuits		
Motor Duty	120VAC	240VAC
Full Load	7.4	3.7
Locked rotor	44.4	22.2
Pilot duty service: 120 and 240VAC, 125 VA		

Model 764 Repair Parts

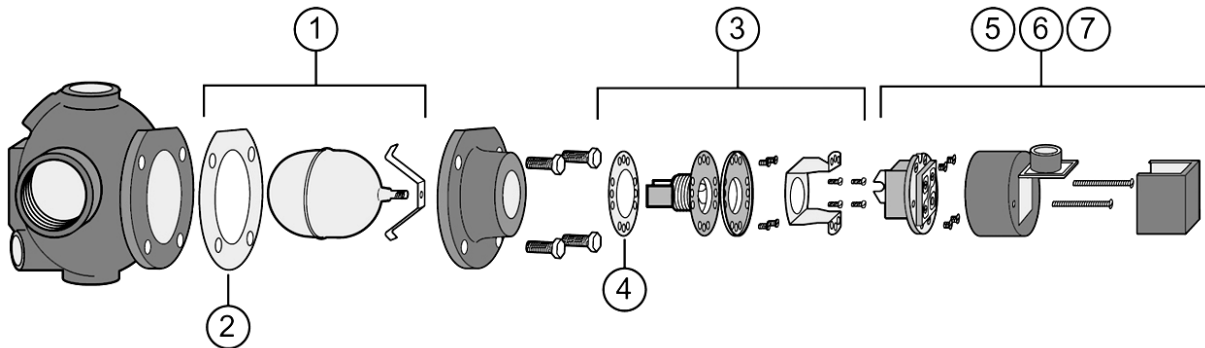

Repair Parts for 764		
Part No.	Description	Order No.
1	Float assembly	MI1310
2	Gasket	MI1170
3	Bellows assembly	MI1305
4	Gasket	MI1110
5	No. 11 switch	MI1010
6	No. 11-M switch, manual reset	MI1012
7	No, 11-MV switch	MI1013
64-HD	Head Assembly	MI1105

No. 764 Head Assembly

The easy way to repair your McDonnell-Miller boiler control! You re-use your old bowl and simply remove your old head assembly, bolt-on the new one.

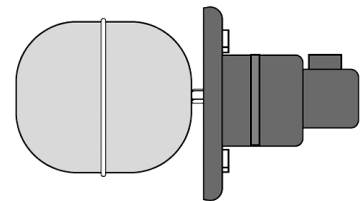

McDonnell-Miller 767 Low Water Cut-Off

No. 767 Low Water Cut-Off for Steam Boilers

The No. 767 is used on steam boilers of any size up to 20 psi. Self contained cut-off for side connection via close nipple into 2½" boiler tapping.

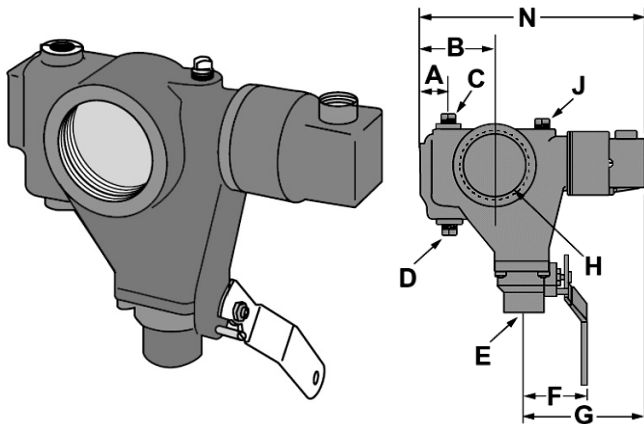

FEATURES:

- For steam and hot water boilers of any steaming capacity.
- Adjustable BX outlet for easy installation.
- Dual precision switches for dependable operation of cut-off, alarm or electric water feeder
- Integral blow down valve
- Maximum boiler pressure, 20 psi
- Automatic reset after low water condition

767 Low Water Cut-Off		
Model No.	Description	Order No.
767	Low water cut-off, 2½" tapping	MH1120

Electrical Ratings		
Ampere ratings for the cut-off circuits		
Motor Duty	120VAC	240VAC
Full Load	7.4	3.7
Locked rotor	44.4	22.2
Pilot duty service: 120 and 240VAC, 125 VA		

Dimensions (inches)

A	B	C	D	E	F	G	H	J	N
1-5/32	3-1/4	3/8	3/8	3/4	2-3/4	5-3/8	2-1/2	1/4	9-3/4

Model 767 Repair Parts

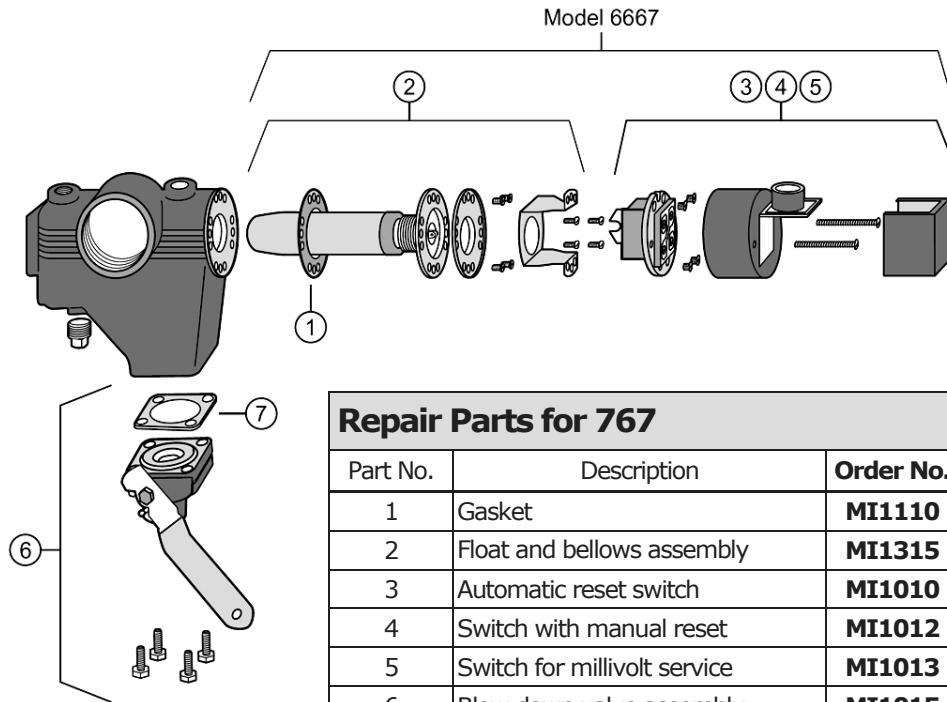

Repair Parts for 767		
Part No.	Description	Order No.
1	Gasket	MI1110
2	Float and bellows assembly	MI1315
3	Automatic reset switch	MI1010
4	Switch with manual reset	MI1012
5	Switch for millivolt service	MI1013
6	Blow down valve assembly	MI1015
7	Gasket for blow down valve	MI1060
6667	Head Assembly (includes 2 to 5)	MI1160

Order the 6667 head assembly for an easy repair of your No. 767 McDonnell-Miller boiler control.

6667 Head Mechanism

McDonnell-Miller 847 Make-Up Water Feeders

No. 847 Make-Up Water Feeder

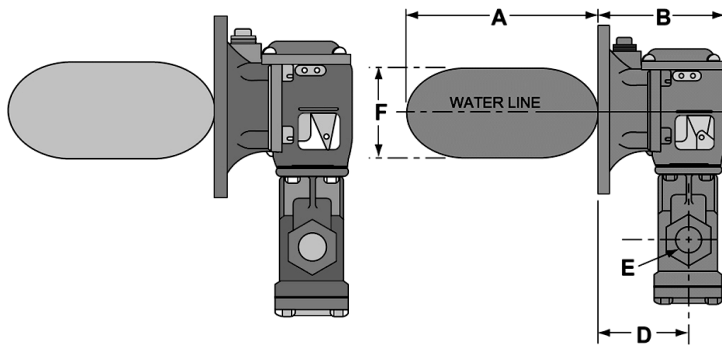

The No. 847 make-up water feeder mounts directly on the tank receiver via a mounting flange with 6-bolt holes on a 5 3/4" bolt circle. No equalizing connections needed. It feeds water through a separate line, permitting anti-siphon air gap in the discharge to the receiver.

FEATURES:

- Mounts directly on receiver tanks
- Mounting flange with 6-bolt holes on a 5 3/4" bolt circle
- Optional models with No. 2 switch and alternate valve orientation
- Maximum water supply pressure, 150 psi
- Maximum inlet water temperature, 120° F
- Maximum receiver pressure for tight closure of the feed valve, 25 psi

Capacities for 847

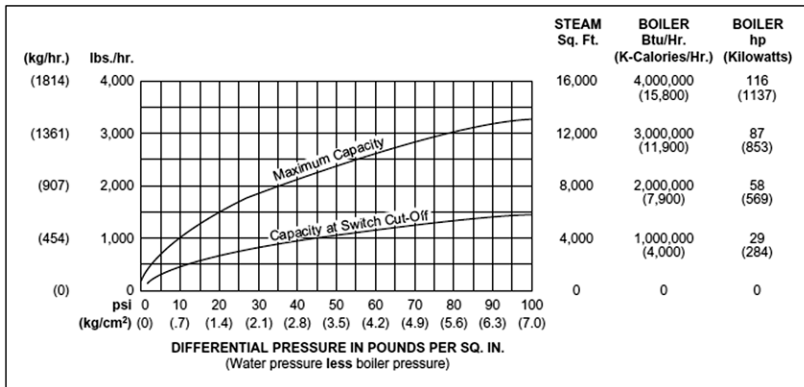

Dimensions of 847 (inches)

A	B	C	D	E	F
7-5/16	4-15/16	4-5/8	3-9/16	1/2	3-7/16

847 Low Water Cut-Off

Model No.	Description	Order No.
847	Make-up water feeder	MH1122
847-C	847 with alternate valve orientation	MH1122A
847-C-2	847-C with No. 2 switch	MH1122B

Model 847 Repair Parts

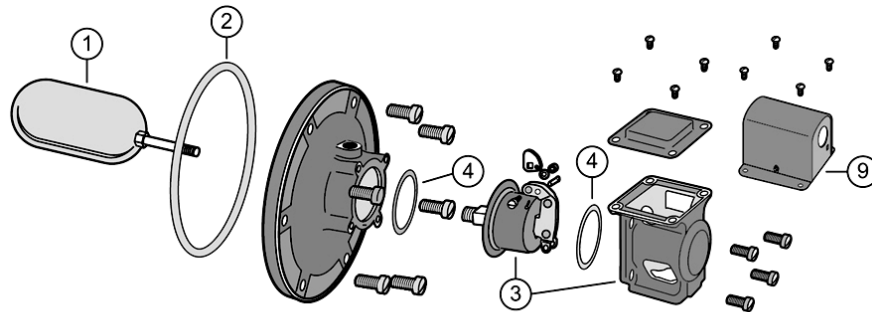

Repair Parts for 847		
Part No.	Description	Order No.
1	Float, includes gasket #2	MI1062
2	Gasket	MI1155
3	Bellows bracket assembly	MI1374
4	Gasket	MI1050
5	Valve & strainer kit	MI1260
6	O-Ring	MI1385
7	Strainer basket kit with bolts and #6	MI1345
8	Cartridge with strainer basket kit	MI1262
9	No. 2 switch	MI1005

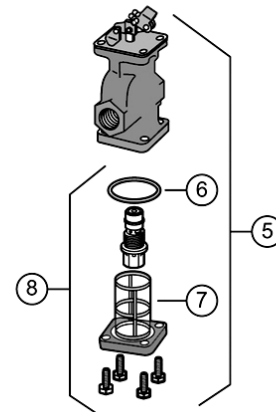

McDonnell-Miller 851 and 851-S Make-Up Water Feeders

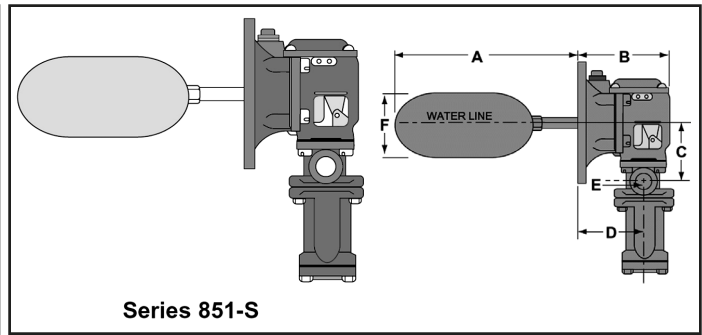
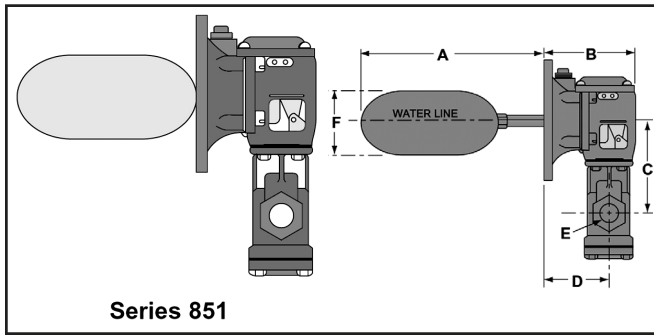

Capacities – Model 851

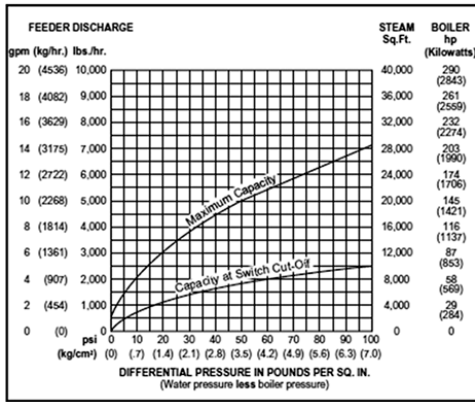

Capacities – Model 851-S

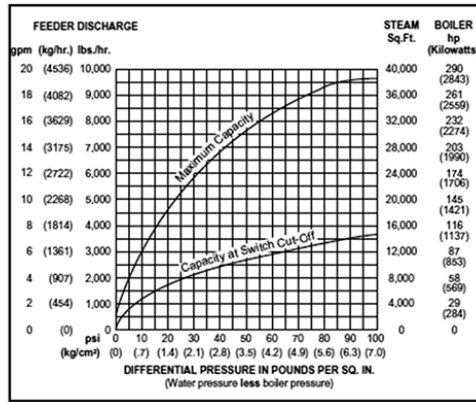

DIMENSIONS (inches)

Model	A	B	C	D	E	F
851	11 3/4	4 7/8	4 5/8	3 1/2	3/4	3 1/2
851S						

851 and 851-S Make-Up Water Feeder

Model No.	Description	Order No.
851	Standard water feeder	MH1123
851-S	Extended range water feeder	MH1123A

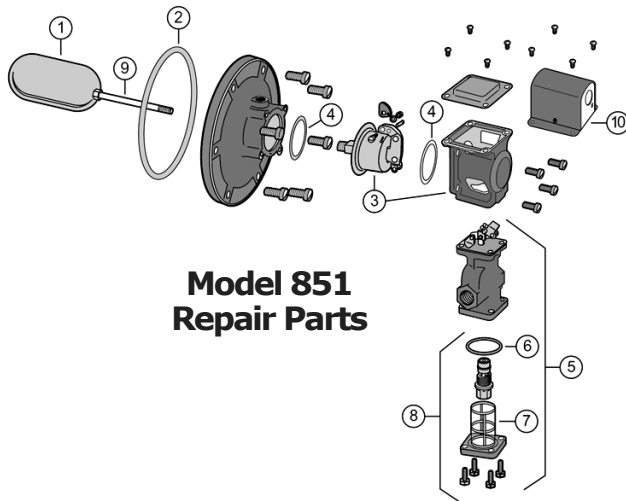

Model 851 Repair Parts

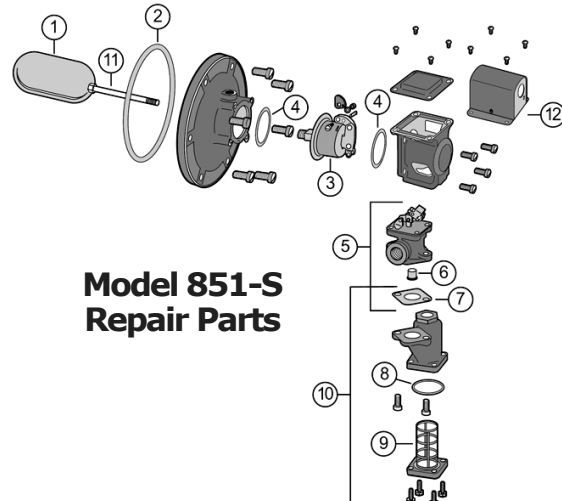

Model 851-S Repair Parts

Part No.	851 Repair Parts	Order No.
1	Float and gasket	MI1062
2	Gasket	MI1155
3	Bellows bracket assembly	MI1374A
4	Gasket	MI1050
5	Valve & strainer/cartridge kit	MI1280
6	O-Ring	MI1385
7	Strainer basket (includes #6 and bolts)	MI1345
8	Cartridge & strainer kit	MI1282
9	Float rod	MI1156
10	No. 2 switch	MI1005

Part No.	851-S Repair Parts	Order No.
1	Float and gasket	MI1062
2	Gasket	MI1155
3	Bellows bracket assembly (includes #4)	MI1374A
4	Gasket	MI1050
5	Valve assembly	MI1285
6	Valve seat	MI1088
7	Gasket	MI1055
8	O-Ring	MI1385
9	Strainer basket (includes #8 and bolts)	MI1240
10	Strainer assembly	MI1269
11	Float rod	MI1157
12	No. 2 Switch	MI1005

McDonnell-Miller FS4-3 Liquid Flow Switches

FS4-3 Series of Flow Switches

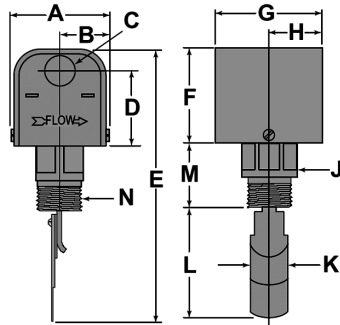
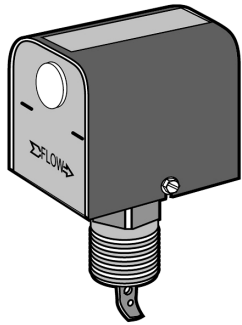

FS4-3 Dimensions (inches)

A	B	C	D	E	F	G
7-5/16	4-15/16	4-5/8	3-9/16	1/2	2-15/16	3-3/8
H	J	K	L	M	N	
1-11/16	1-7/16	1-1/8	3-7/16	2-1/16	1 pipe	

FLOW RATES of FS4-3 Series

Pipe Size	Switch Setting	Flow GPM	No Flow GPM
1	Minimum	6	3.6
1	Maximum	10.2	9.2
1-1/4	Minimum	9.8	5.6
1-1/4	Maximum	16.8	15
1-1/2	Minimum	12.7	23
1-1/2	Maximum	7	19.5
2	Minimum	18.8	32.8
2	Maximum	9.4	24
2-1/2	Minimum	24.3	42.4
2-1/2	Maximum	11.6	37.5
3	Minimum	30	52.1
3	Maximum	12	46.1
4	Minimum	39.7	73.5
4	Maximum	19.8	64.2
5	Minimum	58.7	115
5	Maximum	29.3	92
6	Minimum	79.2	39.6
6	Maximum	166	123

Features of the FS4 Series

- Universal design for wide area of application in starting/stopping electrically operated equipment
- 1" pipe size connection
- Sensitivity adjusting screw makes flow adjustment easy
- Standard with SPDT switch
- Four stainless steel paddles included in lengths 1", 2", 3" and 6"
- Minimum fluid temperature to 32° F; Maximum to 300° F.
- Maximum pressure to 150 psi.

FS4-3 Flow Switches

Model No.	Description	Order No.
FS4-3	Liquid flow switch, SPDT switch	MH1145
FS4-3D	with 2 SPDT switches	MH1148
FS4-3F	for sprinkler service	MH1146A
FS4-MV	for millivolt service, discontinued	
FS4-3S	stainless steel construction	MH1146B
FS4-3DS	SS construction w/SPDT switch	MH1148A
FS4-3RP	with reinforced paddle	MH1146
FS4-3-5R	with 5 second timer delay	MH1149
FS4-3-20	with 20 second timer delay	MH1149A

Replacement Paddles for FS4 Models

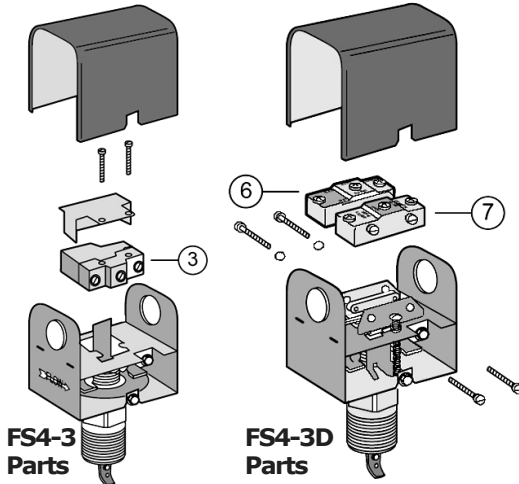
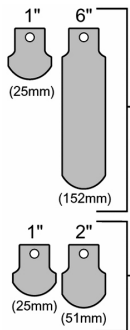

Repair Parts for FS4-3 Series

For Model No.	Item No.	Description	Order No.
FS4-3	4	Stainless Steel paddle kit: 1", 2", 3" and 6" reinforced paddles. The 6" paddle can be trimmed to fit down to 3"	MI1183A
FS4-3D			
FS4-MV			
FS4-3S			
FS4-3DS			
FS4-3-5R			
FS4-3-20			
FS4-3F	5	Paddle kit: 1" and 2" paddles	336801
All Models Except FS4-3D	3	SPDT switch	MI1187
FS4-3D	6	SPDT switch	MI1186
FS4-3D	7	SPDT switch, next to adjustment screw	MI1182
Time Delay Relays			
T5R	5	5 second delay on break, for 120 volts	MH1177
T5R-24V		T5R but for 24 volts	MH1178
T20		20 second delay on make, for 120 volts	MH1180
T20-24V		T20 but for 24 volts	MH1181
T20-24VDC		T20 but for 24 volts DC battery (direct current)	MH1182

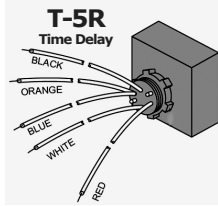

TIME DELAY RELAYS

A short time delay feature in your flow switch may be desirable to eliminate false signals caused by system pulsation and turbulence.

No. T-5R provides a 5-second delay in breaking (opening) the circuit.

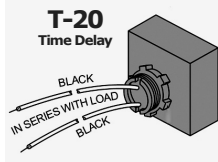

No. T-20 provides a 20-second delay in making (closing) the circuit.

Each model is furnished with a locknut for standard 1/2" conduit fitting, spacer washer and 10" lead wires.

McDonnell-Miller FS4-3T Liquid Flow Switches

FS4-3T Series of Flow Switches

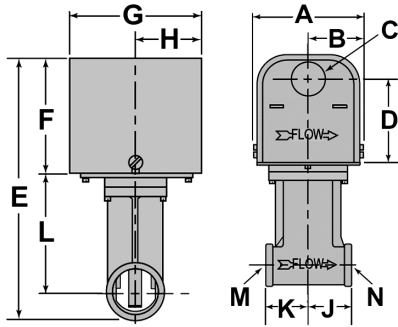
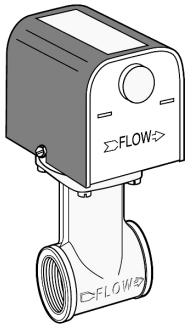

FS4-3T Dimensions (inches)

A	B	C	D	E	F	G
3	1-1/2	7/8	2-7/32	6-7/8	2-15/16	3-3/8
H	J	K	L	M pipe		
1-11/16	1-5/16	1-1/8	3-1/16	3/4 or 1		

FLOW RATES of FS4-3T

Model No.	Switch Setting	Flow GPM	No Flow GPM
FS4-3T1-3/4	Minimum	4.4	2.6
	Maximum	10.5	9.8
FS4-3T2-3/4	Minimum	3.7	2.2
	Maximum	8.9	8.3
FS4-3T3-3/4	Minimum	2	1.2
	Maximum	4.5	4.1
FS4-3T1-1	Minimum	5	3.2
	Maximum	11.5	11
FS4-3T2-1	Minimum	4.8	2.9
	Maximum	10.1	9.4
FS4-3T3-1	Minimum	2	1.2
	Maximum	4.5	4.1

Features of the FS4-3T

- For starting or stopping electrically operated equipment
- Built-in 3/4" or 1" pipe size tee
- Sensitivity adjustment screw makes flow adjustment easy
- SPDT snap-switch
- Available for low, medium and high flow applications
- Minimum fluid temp. to 32° F; Maximum to 300° F
- Maximum pressure to 150 psi.

FS4-3T Flow Switches

Model No.	Pipe Size	Description	Order No.
FS4-3T1-3/4	3/4"	Low flow FS4-3T, 3/4" tee	MH1150
FS4-3T2-3/4	3/4"	Medium flow FS4-3T, 3/4" tee	MH1150B
FS4-3T3-3/4	3/4"	High flow FS4-3T, 3/4" tee	MH1151
FS4-3T1-1	1"	Low flow FS4-3T, 1" tee	MH1150A
FS4-3T2-1	1"	Medium flow FS4-3T, 1" tee	MH1150C
FS4-3T3-1	1"	High flow FS4-3T, 1" tee	MH1150D

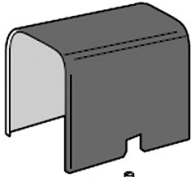

Model FS4-3T Repair Parts

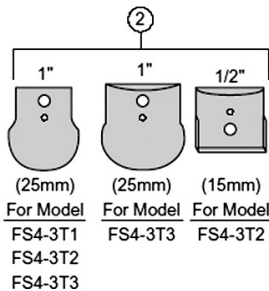
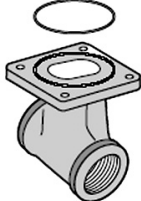
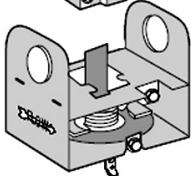
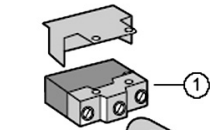

Repair Parts for FS4-3T Series

Item No.	Description	Order No.
1	SPDT Snap-Switch	MI1187
2	Paddle kit includes all 3 paddles and the O-Ring	MI1191

Time Delay Relays

T5R	5 second delay on break, for 120 volts	MH1177
T5R-24V	T5R but for 24 volts	MH1178
T20	20 second delay on make, for 120 volts	MH1180
T20-24V	T20 but for 24 volts	MH1181
T20-24VDC	T20 but for 24 volts DC battery (direct current)	MH1182

TIME DELAY RELAYS

A short time delay feature in your flow switch may be desirable to eliminate false signals caused by system pulsation and turbulence.

No. T-5R provides a 5-second delay in breaking (opening) the circuit.

No. T-20 provides a 20-second delay in making (closing) the circuit.

Each time delay relay is furnished with a locknut for standard 1/2" conduit fitting, spacer washer and 10" lead wires.

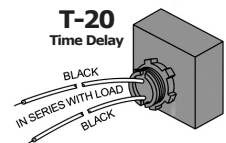
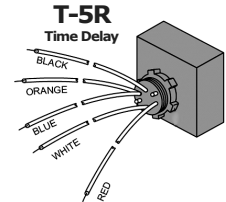

McDonnell-Miller FS5 and FS8-W Liquid Flow Switches

FS5 Series of Flow Switches

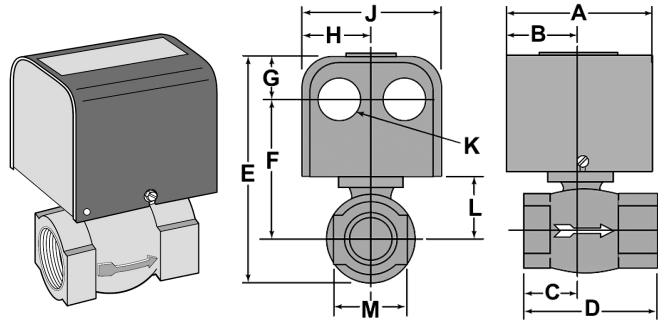

FS5 Dimensions (inches)

A	B	C	D	E	F	G
3-7/16	1-9/16	1-5/16	3-3/16	5-1/16	3-1/4	7/8
H	J	K	L	M		
1-19/32	3-3/16	7/8	1-3/8	1-11/16		

FLOW RATES of FS5 Series

Model No.	Switch Setting	Flow GPM	No Flow GPM
All FS5 Series Flow Switches	Minimum	4.4	2.6
	Maximum	10.5	9.8

FS5 Series Features

- For applications requiring a low flow rate
- For starting, stopping electrical equipment based on flow
- Built-in 3/4" or 1" tee eliminates need for a pipe tee
- SPDT snap-switch & Sensitivity flow adjusting screw
- Minimum fluid temperature to 32° F; Maximum to 225° F steel, 250° F brass. ■ Maximum pressure to 150 psi.

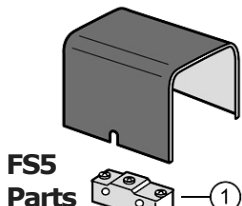

Electrical Ratings for FS5 series		
Voltage	Full Load	Locked Rotor
120	7.4	44.4
240	3.7	22.2
Pilot Duty 125VA at 120 or 240VAC		

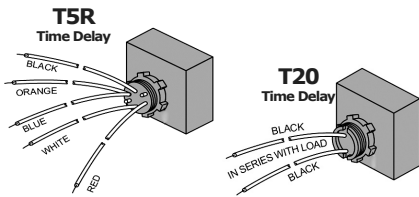

FS5 Flow Switches

Model No.	Pipe Size	Description	Order No.
FS5-3/4	3/4"	Flow switch, 3/4" pipe	MH1155
FS5-1	1"	Flow switch, 1" pipe	MH1156
FS5-D-3/4	3/4"	FS5 with two SPDT switches	MH1157
FS5-D-1	1"	FS5-1 with two SPDT switches	MH1158
FS5-DS-1	1"	FS5-D-1 with stainless steel body	MH1156A
FS5-S-1	1"	FS5-1 with stainless steel body	MH1156B

Repair Parts for FS5 Series

Item No.	Description	Order No.
1	SPDT Snap-Switch	MI1187
Time Delay Relays		
T5R	5 second delay on break, 120 volts	MH1177
T5R-24V	T5R but for 24 volts	MH1178
T20	20 second delay on make, 120 volts	MH1180
T20-24V	T20 but for 24 volts	MH1181
T20-24VDC	T20 but for 24 volts DC battery	MH1182

McDonnell-Miller FS8-W Liquid Flow Switches

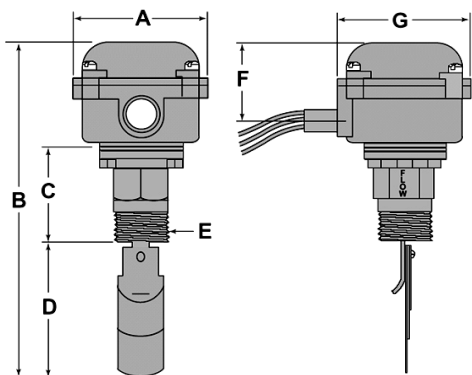

FS8 Series Dimensions (inches)						
A	B	C	D	E	F	G
3-1/4	8-3/8	2-1/4	3-1/2	1	1-3/4	3-1/4

Features of the FS8-W Series

- For general applications requiring water-tight, dust-tight NEMA 4X rating.
- 1" pipe size connection.
- Four paddles included: 1", 2", 3" and 6".
- SPDT snap-switch & Sensitivity flow adjusting screw.
- Minimum fluid temperature to 32° F; Maximum to 225°.
- Maximum pressure to 150 psi.

FS8-W Flow Switches

Model No.	Description	Order No.
FS8-W	Industrial flow switch	MH1170
FS8-WG	FS8 with gold plated contacts	MH1168D
FS8-WG-SL	FS8-WG with sealed leads	MH1168E

Repair Parts

Parts for all the FS8-W models.	O-Ring	MI1196
	SPDT switch	MI1182
	Paddle kit of 4 paddles (1,2, 3 & 6")	MI1183A
	Stainless steel paddle kit (1" & 6")	MI1184

McDonnell-Miller FS1 High Sensitivity Liquid Flow Switches

FS1 Flow Switch

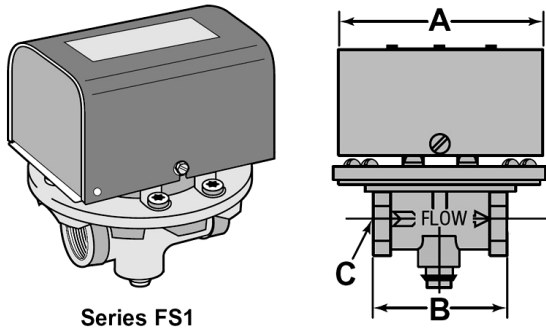

Series FS1

FS1-W Flow Switch

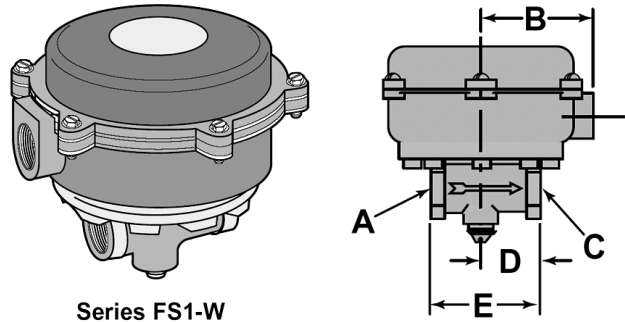

Series FS1-W

FS1 Dimensions (inches)				
A	B	C	D	E
3-3/4	2-5/8	1/2	—	—
FS1-W Dimensions (inches)				
A	B	C	D	E
1/2	2-5/8	1/2	1-3/8	2-5/8

Features of the FS1 Series

- For applications where high sensitivity is required and moderate or low flow rates are encouraged, such as air conditioning, heating and hydronic systems, water, fuel, oil and other related liquids.
- Built-in 1/2" tee eliminates need for a separate pipe tee.
- SPDT snap-switch compartment sealed to protect it from liquid, and Sensitivity flow adjusting screw.
- Minimum fluid temperature to 32° F; Maximum to 225°
- Maximum pressure to 100 psi.

The model **FS1-W** is for applications requiring a water-tight, dust-tight or NEMA 4X rated flow switch.

Flow Rates for FS1 & FS1-W		
Settings	Flow GPM	No Flow GPM
FS1	0.12	.06
FS1-W	2.5	1.5

Electrical Ratings for FS1 series, Ampere ratings			
Voltage	Full Load	Locked Rotor	Pilot Duty
120	7.4	44.4	125VA at 120 or 240VAC
240	3.7	22.2	

FS1 High Sensitivity Flow Switches

Model	Description	Order No.
FS1	High sensitivity flow switch	MH1140
FS1-W	FS1 with NEMA 1 dust- and water-tight enclosure for tough environments	MH1139

Do not use flow switches on systems with flow greater than 10 feet per second.

Repair Parts for FS1 Series		
Item No.	Description	Order No.
1	O-Ring	MI1194B
2	SPDT Snap-Switch	MI1187
Time Delay Relays		
T5R	5 second delay on break, for 120 volts	MH1177
T5R-24V	T5R but for 24 volts	MH1178
T20	20 second delay on make, for 120 volts	MH1180
T20-24V	T20 but for 24 volts	MH1181
T20-24VDC	T20 but for 24 volts DC battery (direct current)	MH1182

TIME DELAY RELAYS A short time delay feature in your flow switch may eliminate false signals caused by system pulsation and turbulence. **No. T-5R** provides a 5-second delay in breaking (opening) the circuit. **No. T-20** provides a 20-second delay in making (closing) the circuit. Each is furnished with a locknut for 1/2" conduit fitting, washer & 10" lead wires.

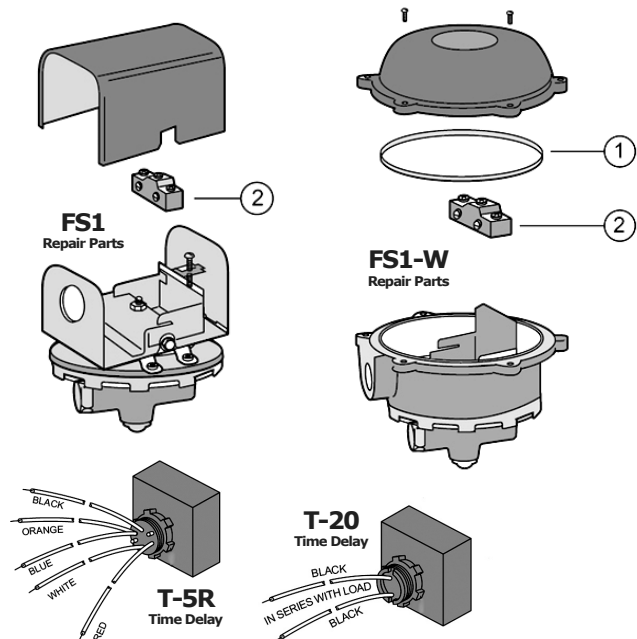

McDonnell-Miller FS6 Series Liquid Flow Switches

FS6 Flow Switch

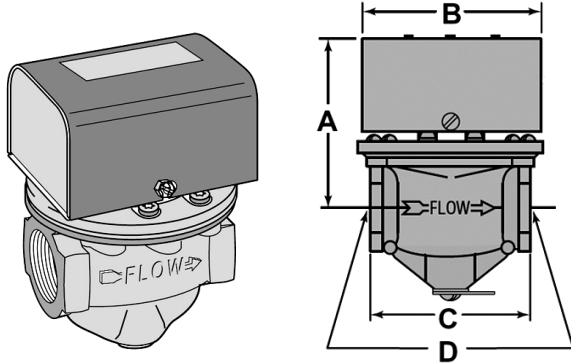

Features of the FS6 Series

- For applications where high sensitivity is required, such as water treatment systems, cooling systems for electronic circuits, compressors, booster pumps, bearings and other applications that need instant switching.
- Built-in 3/4" or 1" tee.
- Very high flow capacity.
- Actuates at extremely low flow rates.
- SPDT snap-switch compartment sealed to protect it from liquid, and Sensitivity flow adjusting screw.
- Minimum fluid temperature to 32° F; Maximum to 225°
- Maximum pressure to 100 psi.

The model **FS6-W** is for applications requiring a water-tight, dust-tight or NEMA 4X rated flow switch.

Do not use flow switches on systems with flow greater than 10 feet per second.

Repair Parts for FS6 Series

Item No.	Description	Order No.
1	O-Ring	MH1194B
2	SPDT Snap-Switch	MH1182

Time Delay Relays

T5R	5 second delay on break, for 120 volts	MH1177
T5R-24V	T5R but for 24 volts	MH1178
T20	20 second delay on make, for 120 volts	MH1180
T20-24V	T20 but for 24 volts	MH1181
T20-24VDC	T20 but for 24 volts DC battery (direct current)	MH1182

TIME DELAY RELAYS

A short time delay feature in your flow switch may be desirable to eliminate false signals caused by system pulsation and turbulence.

No. T-5R provides a 5-second delay in breaking (opening) the circuit. **No. T-20** provides a 20-second delay in making (closing) the circuit. Each is furnished with a locknut for standard 1/2" conduit fitting, spacer washer and 10" lead wires.

FS6-W Flow Switch

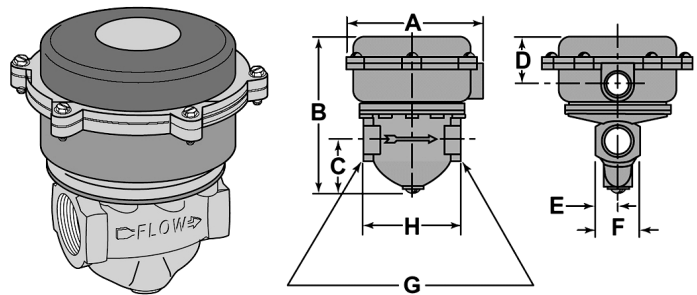

FS6-W Dimensions (inches)

A	B	C	D	E	F	G pipe	H
5	5¾	2	1⅝	⅞	1¾	¾ or 1	3⅝

FS6 Dimensions (inches)

A	B	C	D pipe
3½	3¾	3⅝	¾ or 1

Flow Rates for FS6 & FS6-W

Models	Flow GPM	No Flow GPM
FS6	0.12	.06
FS6-W	2.5	1.5

Electrical Ratings for FS6 series, Ampere ratings

Voltage	Full Load	Locked Rotor	Pilot Duty
120	7.4	44.4	125VA at 120 or 240VAC
240	3.7	22.2	

FS6 High Sensitivity Flow Switches

Model	Description	Order No.
FS6-3/4	High sensitivity, 3/4" pipe	MH1159
FS6-1	High sensitivity, 1" pipe	MH1160
FS6-W-3/4	NEMA 4X, 3/4" pipe	MH1160A
FS6-W-1	NEMA 4X, 1" pipe	MH1160B

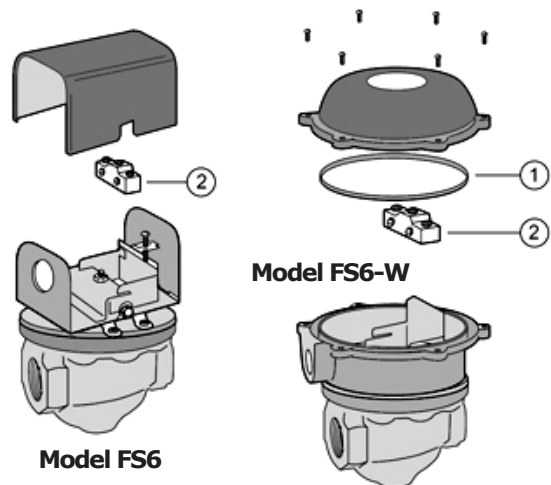

McDonnell-Miller FS7 Series Liquid Flow Switches

FS7-4 Flow Switch

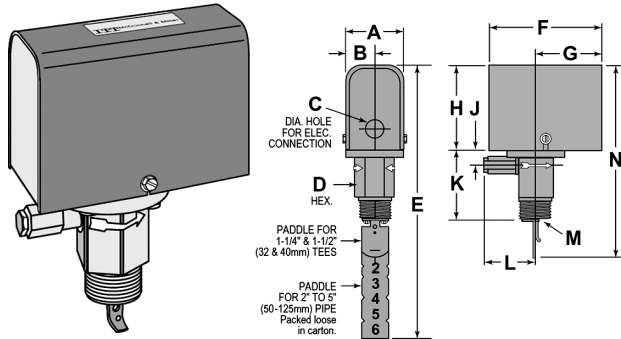

FS7-4E and FS7-4W Flow Switch

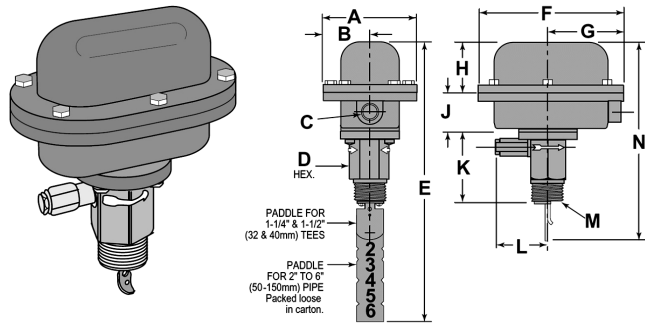

Features of the FS7 Series

- Universal design for large pipe applications for heating and hydronic systems, air conditioning, refrigeration, etc.
- The "E" and "W" models are NEMA rated for hazardous environments.
- Built-in 1-1/4" connection with SPDT mercury-free switch action.
- Paddles can be trimmed to fit in the field.
- Sensitivity flow adjusting screw.
- SPDT snap-switch compartment sealed to protect it from liquid, and Sensitivity flow adjusting screw.
- Minimum fluid temperature to 32° F; Maximum to 300° ("W" - 65 to 300°)
- Maximum pressure to 300 psi; stainless steel model to 1000 psi.

FS7 Flow Switches

Model	Description	Order No.
Standard FS7 Flow Switches		
FS7-4	Industrial flow switch	MH1165
FS7-4A	Industrial flow switch with air valve	MH1165A
FS7-4D	FS7-4 with 2 SPDT switches	MH1165B
FS7-4DF	FS7-4D for sprinkler service	MH1165C
FS7-4DS	FS7-4D, stainless steel body	MH1165D
FS7-4F	FS7-4 for sprinkler service	MH1165F
FS7-4L	FS7-4, extended paddle (12")	MH1168
FS7-4S	FS7-4, stainless steel body	MH1168A
NEMA Rated FS7 Flow Switches		
FS7-4E	Industrial flow switch, NEMA 7 & 9	MH1167
FS7-4EL	FS7-4E, extended paddle (12")	MH1165E
FS7-4SE	FS7-4E, stainless steel body	MH1168B
FS7-4W	Industrial flow switch, NEMA 4X	MH1166
FS7-4SW	FS7-4W, stainless steel body	MH1168C
FS7-4WL	FS7-4W, extended paddle (12")	MH1169

FS7 Series Flow Rates

Pipe Size	Set	Flow GPM	No Flow GPM
1 1/4	Min	4.8	3
1 1/4	Max	7.7	5.9
1 1/2	Min	6.3	3.6
1 1/2	Max	10	7
2	Min	9.9	5.9
2	Max	15.8	11
2 1/2	Min	15.3	9.5
2 1/2	Max	23.7	17
3	Min	24.4	15.4
3	Max	35.5	29.2
4	Min	33.3	21.1
4	Max	61.4	37.7
5	Min	44.4	31
5	Max	84	51
6	Min	56.3	48.7
6	Max	114.8	71
8	Min	104	89
8	Max	210	131

FS7-4 Dimensions (inches)

A	B	C	D	E	F	G	H	J	K	L	M	N
2-7/8	1-7/16	7/8	1-3/4	13-9/16	5-13/16	3-3/8	4-1/8	15/16	3-7/16	2-5/8	1-1/4	9-1/2

FS7-4E and FS7-4W Dimensions (inches)

A	B	C	D	E	F	G	H	J	K	L	M	N
4-5/8	2-5/16	1/2	1-3/4	13-3/4	7-1/4	3-3/4	2-7/16	15/16	3-7/16	2-5/8	1-1/4	9-3/4

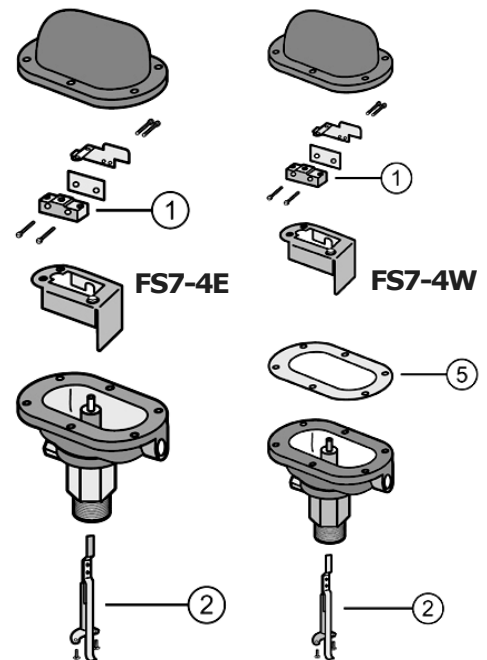

Repair Parts FS7 Series

Item No.	Description	Order No.
1	SPDT switch	MI1193C
2	Paddle arm	MI1193F
3	Paddle, 1"	MI1193
4	Paddle, 6" (trim to fit)	MI1193B
5	Gasket	MI1193E
6	Paddle arm, FS7-4L	MI1193D

McDonnell-Miller AF Series Air Flow Switches

Model AF1

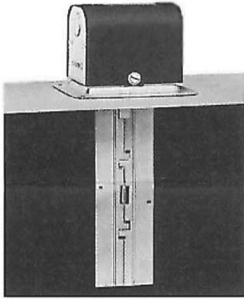

Horizontal Duct
Top Mount

Model AF2

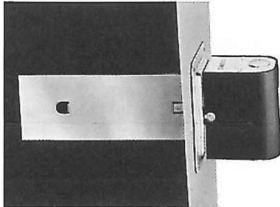

Horizontal Duct
Side Mount

Model AF3

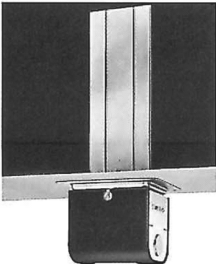

Horizontal Duct
Bottom Mount

Features of the AF Series

- Select from models **AF1, AF1-E, AF2 and AF3.**
- For general applications with medium and high velocity requirements.
- Order the appropriate top, side or bottom mount.
- Sensitivity flow adjusting screw
- Actuates at extremely low flow rates.
- SPDT mercury-free snap-switch
- Minimum air temperature to 32° F; Maximum to 300°

Flow Rates (inches) of AF Series Air Flow Switches

Model No.	Settings	Flow FPM	No Flow FPM
AF1, 7¼" paddle	MIN	480	185
	MAX	1385	1160
AF1, 5¼" paddle	MIN	700	220
	MAX	2230	1820
AF2	MIN	300	100
	MAX	1900	500
	MIN	350	100
	MAX	1950	900
AF3, horizontal	MIN	235	175
	MAX	1445	1365
AF3-D, horizontal	MIN	295	220
	MAX	1445	1000
AF3, vertical	MIN	450	430
	MAX	1470	1395
AF3-D, vertical	MIN	560	540
	MAX	1470	1030

AF Air Flow Switches		
Model	Description	Order No.
AF1	Air flow switch complete	MH1130
AF1-S	AF1, stainless steel	MH1131
AF2	Low velocity air switch	MH1134
AF3	Lowest velocity switch	MH1135
AF3-D	AF3, two SPDT switches	MH1135A

Repair Parts for AF Series		
Item No.	Description	Order No.
1	Switch for <u>all</u> AF models	MI1193C
2	Gasket for <u>all</u> AF models	MI1162
3	Paddle kit for AF1	MI1162A
3	Paddle kit for AF2	MI1163
3	Paddle kit for AF3	MI1163A
4	Paddle kit for AF1-S	MI1162B

Paddle kits includes washers and screws.
Units can be equipped with time delay relays.

AF1 Parts

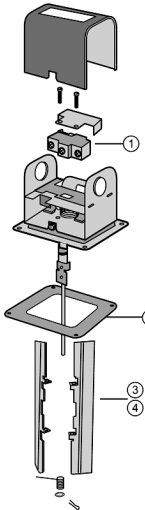

AF2 Parts

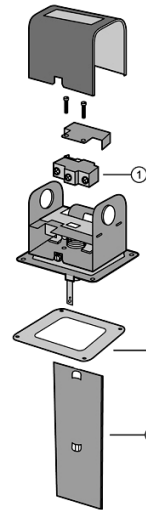

AF3 Parts

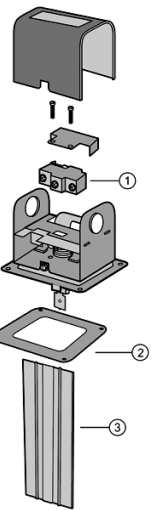

Model AF1-E

- For hazardous environments with medium velocity requirements.
- NEMA 7 and 9 rated.
- Sensitivity flow adjusting screw
- 1/2" pipe connection
- SPDT mercury-free snap-switch
- Maximum air temp. to 300°

AF1-E Air Flow Switch		
Model	Description	Order No.
AF1-E	Air flow switch, NEMA	MH1136

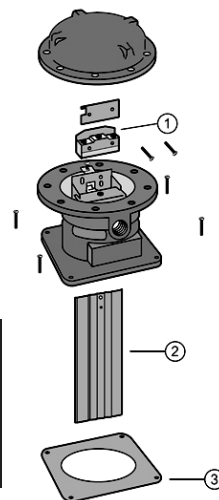

Repair Parts for AF1-E

Item No.	Description	Order No.
1	Switch	MI1182
2	Paddle kit	MI1164A
3	Gasket	MI1164

Flow Rates of AF1-E

Mounting	Settings	Flow FPM	No Flow FPM
Top	MIN	480	185
	MAX	1385	1160
Side	MIN	700	220
	MAX	2230	1820

McDonnell-Miller 27-W Liquid Level Control

27-W Liquid Level Control

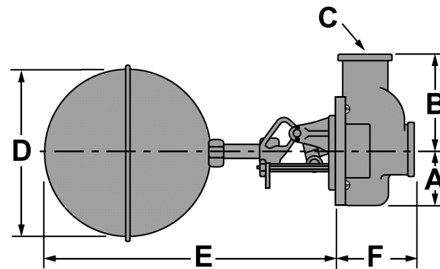
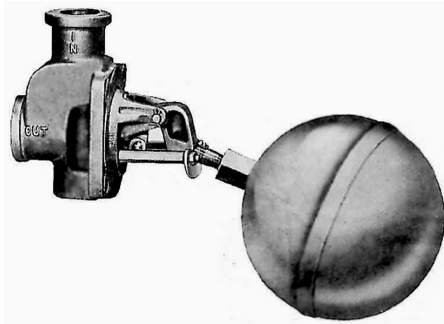

27W Dimensions (inches)					
A	B	C	D	E	F
1-9/16	2-7/8	3/4	5	8-5/8	2-7/16

Features of the 27-W Liquid Level Control

- For commercial and industrial applications for liquid levels in tanks.
- 3/4" pipe size connection.
- Brass valve with stainless steel float.
- Monel valve seat for long-lasting seal.
- Delivers over 12 gpm at 30 psi differential pressure.
- Maximum operating pressure to 35 psi
- Maximum supply pressure to 100 psi.
- Maximum liquid temperature range from 40° below zero to 212° Fahrenheit.

27-W Liquid Level Control		
Model	Description	Order No.
27-W	Liquid level control, 3/4" pipe size	MH1017

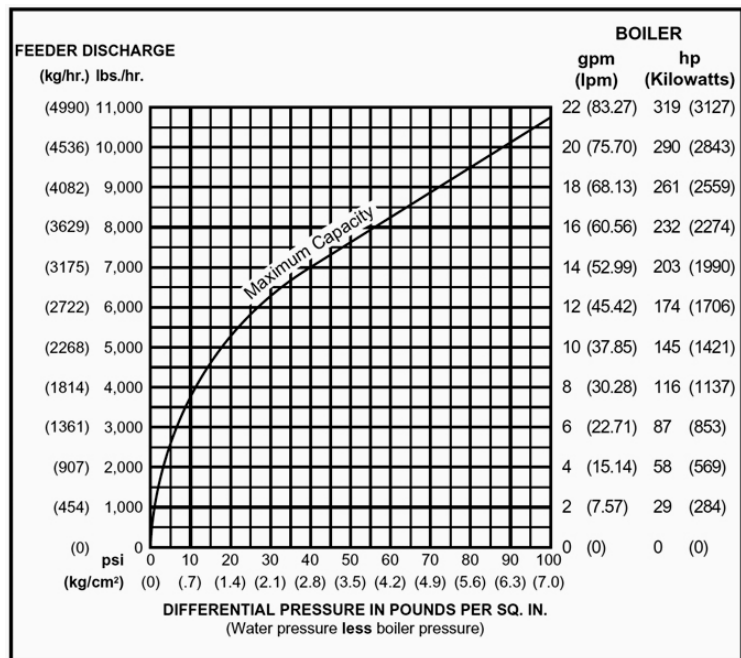

Repair Parts for 27-W		
Item No.	Description	Order No.
1	Float	MI1150
2	Gasket	MI1025
3	Valve assembly	MI1233

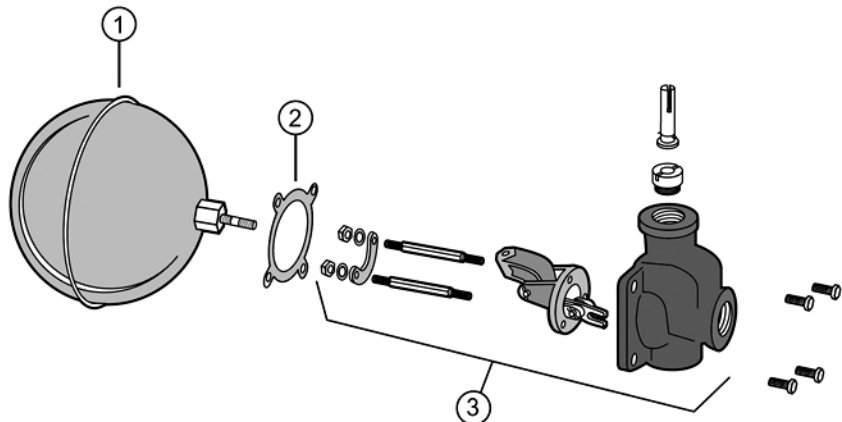

McDonnell-Miller 65 & 165 Liquid Level Controls

DISCONTINUED — Model 65 and 165

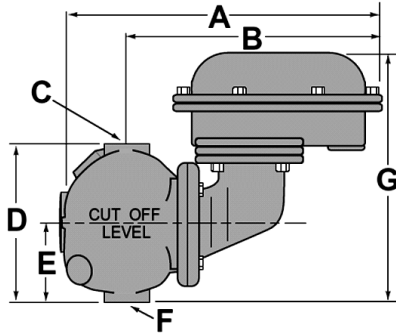
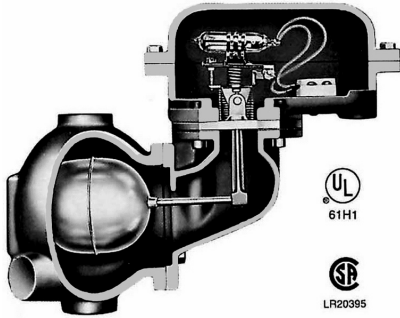

65 and 165 Dimensions (inches)					
A	B	C	D	E	F
1-9/16	2-7/8	3/4	5	8-5/8	2-7/16

Electrical Ratings for 65 and 165 Models, Ampere ratings			
Voltage	Full Load	Locked Rotor	Pilot Duty
120VAC	9.8	58.8	125 VA at 120 or 240 VAC
240VAC	4.9	29.4	

65 and 165 Liquid Level Controls		
Model No.	Description	Order No.
65	Low water cut-off	Discontinued by McDonnell-Miller
65-R	65 with reverse acting switch	
165	65 with vapor-proof construction	
165-R	165 with reverse acting switch	

Repair Parts for 65, 165 Series		
Item	Description	Order No.
1	Gasket	MI1170
2	Float with stem and gasket (#1)	MI1295
3	Direct-action switch	Discontinued by McDonnell-Miller
4	Reverse-action switch	
65-HD	Head assembly for 65, direct-action	
65-R-HD	Head assembly, reverse-action	
165-HD	Head assembly, direct-action	
165-R-HD	Head assembly, reverse-action	

The Models 65 and 165 were taken out of production by McDonnell-Miller in 2005.

The products and repair parts are shown here for reference purposes only.

The replacement gasket and float (items 1 and 2) are currently available for purchase.

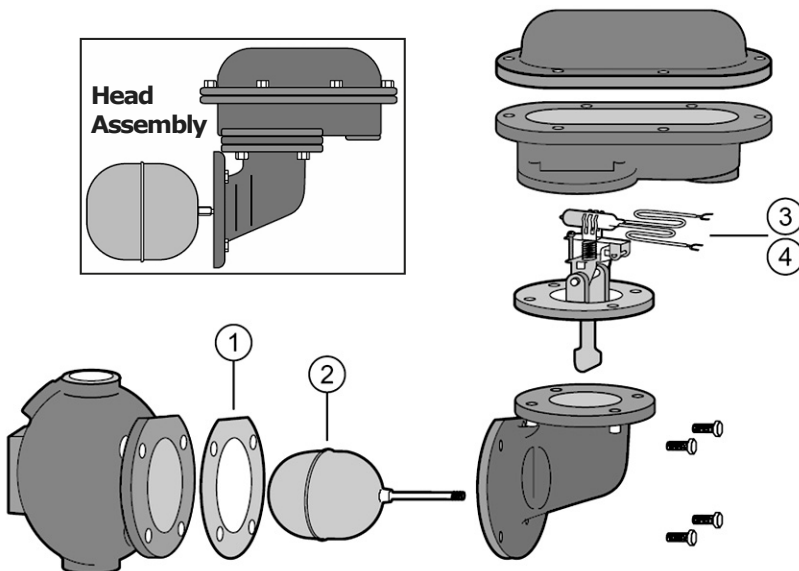
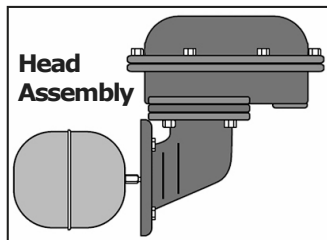

Features of the Discontinued 65

- For liquid level controls in tanks located in a hazardous environment; NEMA 7 and 9 listed.
- Standard SPST mercury switch: Breaks with falling liquid levels; Makes with rising liquid levels
- Reverse acting switch models available: Makes with falling liquid levels; Breaks with rising liquid levels.
- Dual switches for cut-off and alarm or electric water feeder, and 1/4" npt pressure control tapping.
- Max. operating pressure, 40 psi.
- Maximum liquid temp. to 287° F.

Features of Discontinued 165

Same as the 65 features except:

- "Vapor-Proof" for liquid storage tanks subject to an outdoor environment or high humidity.
- Max. operating pressure, 50 psi.
- Maximum liquid temp. to 287° F.

McDonnell-Miller 3155 Liquid Level Control

Model 3155

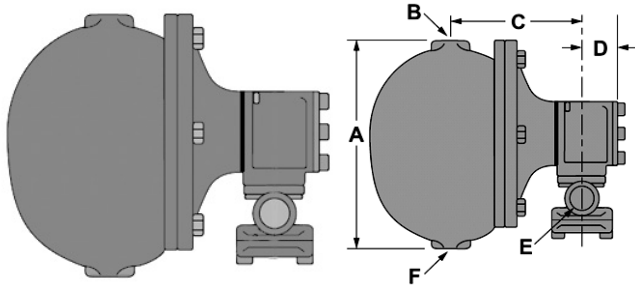

Features of the 3155

- For feeding water and controlling the liquid level in medium and large-sized solvent still applications.
- High capacity feed.
- Monel bellows.
- Stainless steel valve and seat.
- Maximum supply pressure, 25 psi.
- Maximum operating pressure, 15 psi.

3155 dimensions (inches)

A	B	C	D	E	F
10-1/2	1	6-11/16	2	1	1

Capacities for 3155

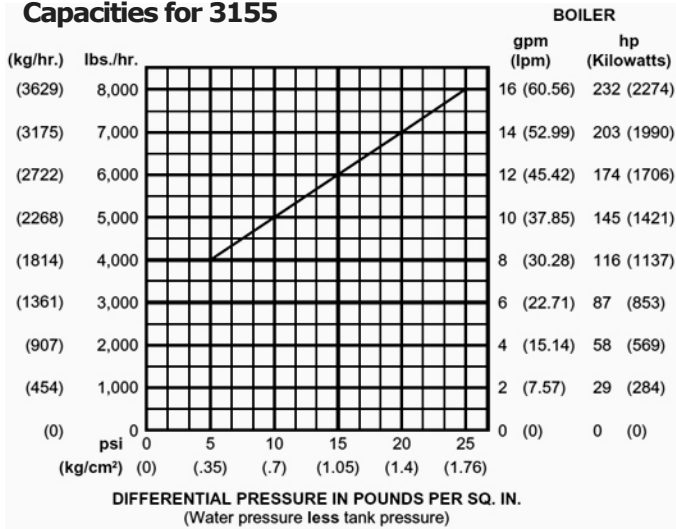

3155 Liquid Level Control

Model No.	Description	Order No.
3155	Liquid level control for solvent stills	MH1123B

Repair Parts for 3155

Item	Description	Order No.
1	Float	MI1275A
2	Gasket	MI1180
3	Bellows assembly	MI1373A
4	Gasket	MI1050
5	Gasket	MI1149G
6	Gasket	MI1149F
7	Gasket	MI1055
8	Valve assembly	MI1375
	Head assembly for 3155	MI1158

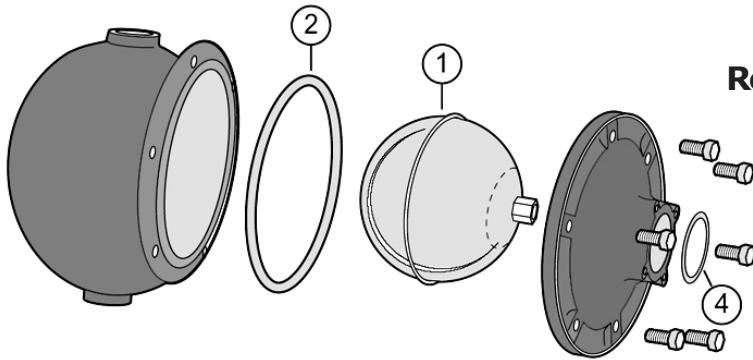

Head Assembly

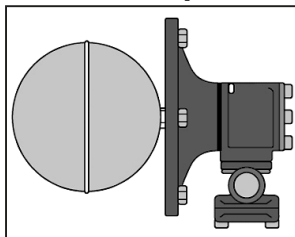

Repair Part Diagram for 3155

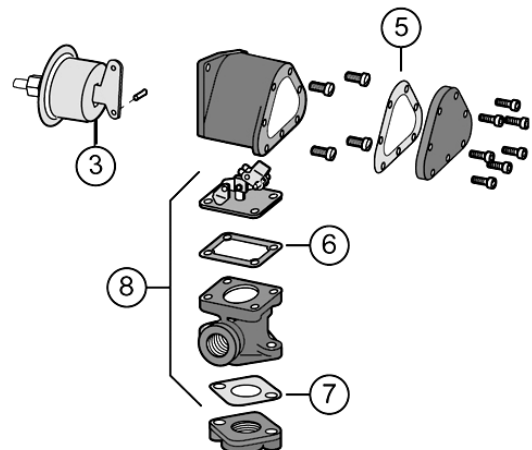

McDonnell-Miller PFC Liquid Level Control

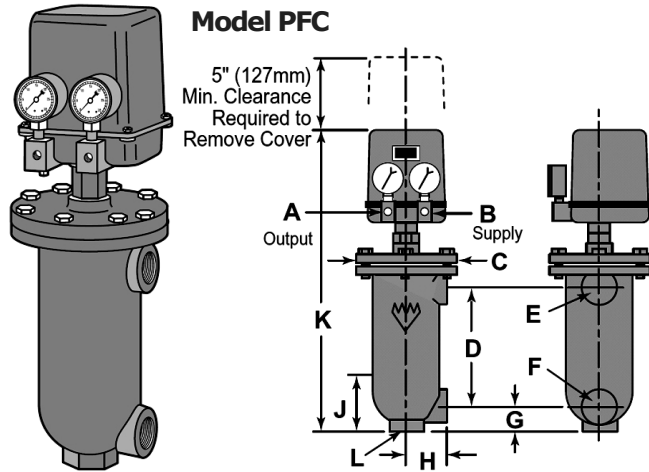

Features of the PFC Pneumatic Actuated Control

- For the actuation of pneumatic valves or relays in heating, air conditioning and process systems in hazardous and non-hazardous locations. Provides an air pressure signal proportional to the liquid level.
- Available as direct or reverse acting.
- Switch mechanism is completely sealed from the liquid.
- Level adjustment range from 1" to 2"
- Two gauges display the supply and output pressure, while the alternate air connection tapplings provide piping flexibility.
- Air pressure supply to 20 psi; Output range — 2 to 15 psi
- Maximum water temperature to 406° F.
- Maximum pressure to 250 psig.

Proportional Band 100%
Operating Range 2" (51mm)

Capacity Chart

50% 1" (25mm)

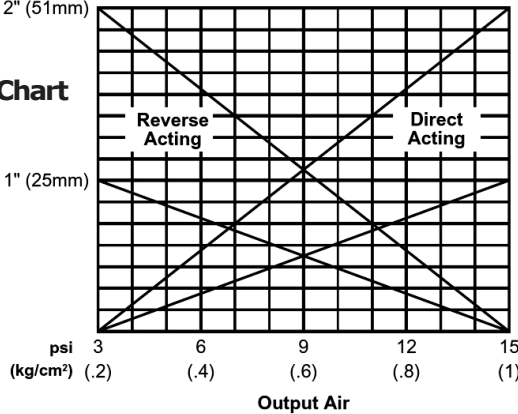

PFC dimensions (inches)

A pipe	B pipe	C	D	E pipe	F pipe	G	H	J	K	L pipe
1/8	1/4	7	8	1	1	1-3/4	2-5/8	4	20-3/4	1

PFC Pneumatic Liquid Level Control

Model No.	Description	Order No.
PFC-1-G	Direct acting pneumatic control	MH1171
PFC-1-GR	Reverse acting pneumatic control	MH1171A

PFC Repair Parts

Repair Parts for PFC

Item	Description	Order No.
1	Valve assembly, direct acting	MI1378C
2	Valve assembly, reverse acting	MI1378D
3	Supply gauge	MI1194A
4	Output gauge	MI1194
5	Float and gasket	MI1181
6	Gasket	MI1194C

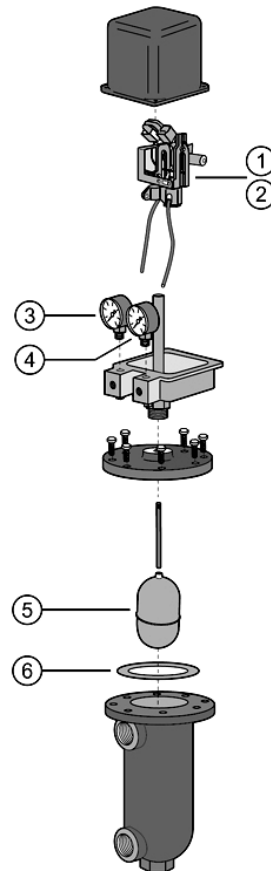

McDonnell-Miller Test-N-Check Valves

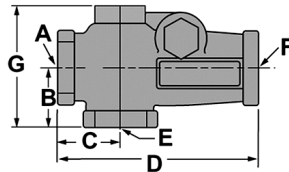
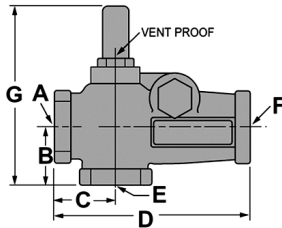
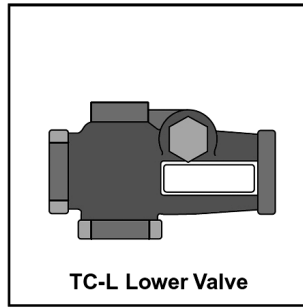
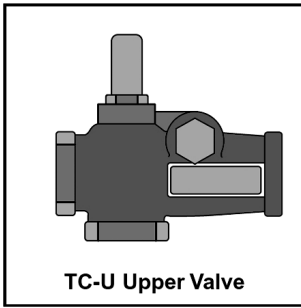

Valve dimensions (inches)						Upper	Lower
A	B	C	D	E	F	G	G
1	1-1/2	1-1/2	5	1	1	5-1/4	3-1/16

Test-N-Check Valves		
Model No.	Description	Order No.
TC-4	Complete valve set, upper & lower	MH1175
TC-U	Upper valve only	MI1379A
TC-L	Lower valve only	MI1379
TCV	Repair kit: vacuum breaker & gasket	MI1379B

Sample Installation Diagram

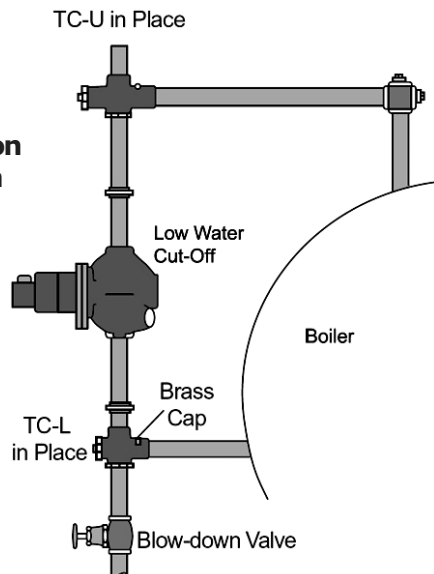

Features of the Test-N-Check Valves

- Simplifies code mandated testing of low water cut-offs by eliminating the need to drain the system.
- Used only for Hot Water Boilers.
- Install at the crosses in the equalizing lines.
- Restricts water flow when the low water cut-off's blow-off valve is opened.
- Adjustable built-in vacuum breaker in the upper valve provides rapid evacuation of water from the low water cut-off's float chamber.
- 1" pipe size connections.
- Maximum pressure to 160 psig.
- Maximum temperature to 250° F.

Product Date Code Guide

Sometimes you need to identify the year your McDonnell-Miller product was manufactured.

Here you go . . .



McDonnell & Miller

Product Date Code Translation

Month	Year	Example	
A = January	W = 1979 X = 1980	<p>K09 Translates to October 1990</p>	
B = February	Y = 1981 Z = 1982		
C = March	38 = 1983 48 = 1984		
D = April	58 = 1985		
E = May	68 = 1986 78 = 1987		
F = June	88 = 1988 98 = 1989		
G = July	09 = 1990		
H = August	19 = 1991 29 = 1992		
J = September	39 = 1993 49 = 1994		
K = October	59 = 1995		
L = November	96 = 1996 97 = 1997		<p>Beginning 1996 the year is no longer reversed. 96K Translates to October 1996</p>
M = December	98 = 1998 99 = 1999		
	00 = 2000 01 = 2001		
	02 = 2002 03 = 2003 04 = 2004		