



Pneumatic Fittings, Controls, and Accessories

Contents

Pneufit® Inch Series FittingsFIT-1-1
Pneufit® Metric Series FittingsFIT-2-1
Function Fittings, Flow Controls, Accessory ValvesFIT-3-1
FleetFit® Vehicle Push-In FittingsFIT-4-1
WeldFit® Fittings and TubingFIT-5-1
Cartridge FittingsFIT-6-1
Tubing and AccessoriesFIT-7-1
Quietaire® MufflersFIT-8-1
Miniature Control Devices and Pneumatic Accessories . .	.FIT-9-1
Conversion FactorsFIT-10-2
Chemical Resistance ChartFIT-10-3
Numerical Part IndexFIT-10-4
Warning and WarrantyFIT-10-5

Pneufit® Inch Series Push-In Tube Fittings

1/8" to 1/2" Tube Sizes
10-32 UNF to 1/2" NPT
Thread Options

Inch Series Product Numbering System	FIT-1-2
Inch Series Shapes and Codes	FIT-1-3
Inch Series Specifications	FIT-1-4
Inch Series Features and Benefits	FIT-1-5
Inch Series Part Numbers and Dimensional Information	FIT-1-6

Pneufit 12 Series

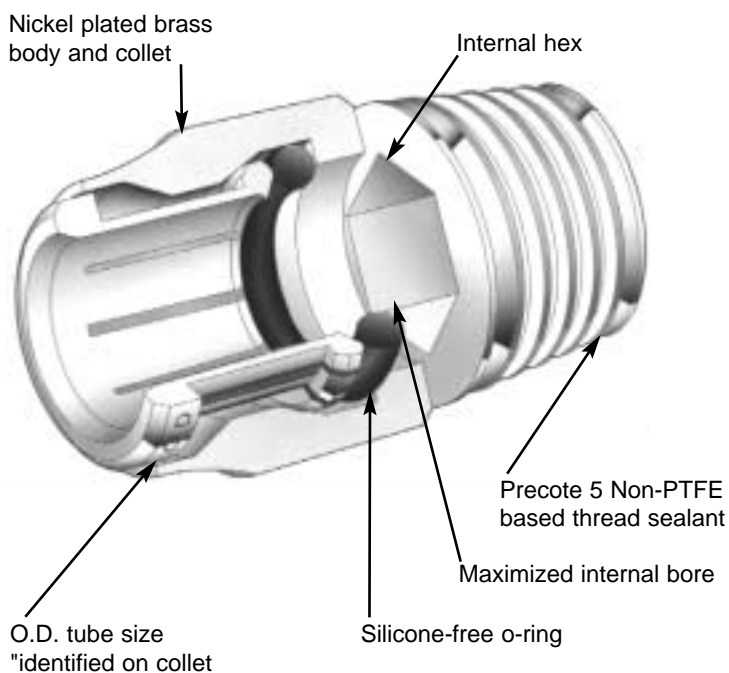

Pneufit C2 Series

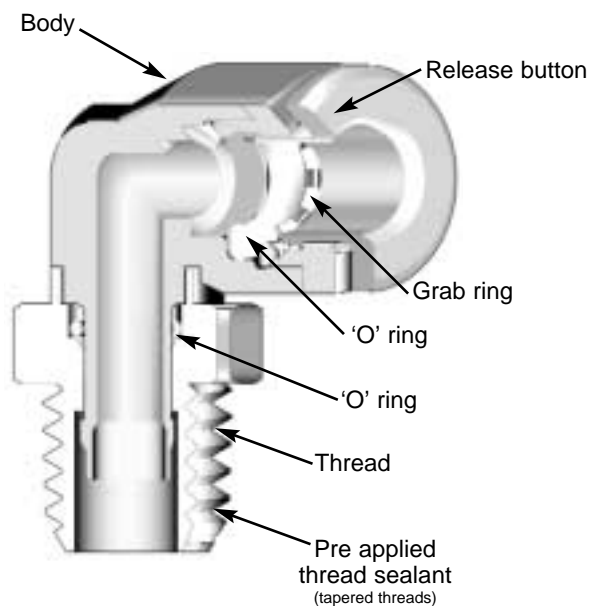



Product Numbering System

Position → **1 2** **3 4 5** **6 7 8 9** **(V)**

Fitting Series Number

- 10 Brass push-in fittings (metric) nickel plate + washers, sealant, assembled
- 11 Plastic push-in fittings (metric)
- 12 Brass push-in fittings (inch) nickel plate + washers, sealant assembled
- 13 Plastic push-in fittings (inch)
- 15 ISO R Pipe Fittings Brass Nickel Plate
- 16 ISO G Pipe Fittings Brass Nickel Plate + Washers Assembled
- 20 ISO G Banjo Bolts
- 21 Metric WeldFit
- 33 Inch WeldFit
- C0 Pneufit Metric
- C2 Pneufit Inch

Suffix Position (Optional)

- BP Bulk packaging
- GR ISO R thread
- V Viton seals 10/12 Series only
- XA Without thread sealant

Thread Size

- | | |
|---------------|----------|
| 18 | 1/8 |
| 28 | 1/4 |
| 38 | 3/8 |
| 48 | 1/2 |
| UNF | |
| 10 | 10-32 |
| Metric | |
| 05 | M5 x 0.8 |

Thread/Banjo Bolt

- 0 No port thread
- 1 ISO R
- 2 ISO G + M5
- 4 NPTF + 10-32 UNF
- A Single bolt
- B Double bolt
- C Triple bolt
- D Single bolt M5 top port
- E Single bolt G 1/8 top port
- F Single bolt G 1/4 top port
- G Single bolt G 3/8 top port
- J Single bolt with test point
- K ISO G Single bolt - regulating out
- T ISO R Single bolt - regulating out
- V NPTF Single bolt - regulating out
- W NPTF Single bolt - regulating out
- Z NPTF Single bolt - bi-directional

Tube Size

Inch O.D.		Metric O.D.	
01	1/8"	04	4 mm
02	5/32"	05	5 mm
03	3/16"	06	6 mm
04	1/4"	08	8 mm
05	5/16"	10	10 mm
06	3/8"	12	12 mm
07	1/2"	14	14 mm

Fitting Shape

See facing page for shapes and codes.



Positions 4 and 5 denote fitting shape

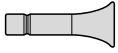

04 Plug – O.D. Tube Stem
p. FIT-1-27.

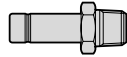

15 Stem adapter – O.D. tube stem to male thread
p. FIT-1-(18-19)



19 Barbed adapter – O.D. tube stem to hose bore
p. FIT-1-27.



20 Union – O.D. tube to O.D. tube
p. FIT-1-8.



22 Double Male Union – O.D. tube stem to O.D. tube
p. FIT-1-9.

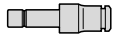

23 Tube End Expander/Reducer – O.D. tube stem to O.D. tube
p. FIT-1-10.



24 Self Sealing (Checked) Connector – O.D. tube to male thread
p. FIT-1-17



25 Male Connector – O.D. tube to male thread
p. FIT-1-(14/16/17)



26 Female Connector – O.D. tube to female thread
p. FIT-1-20.

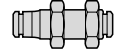

29 Bulkhead Union – O.D. tube to O.D. tube
p. FIT-1-11.



32 Female Bulkhead Connector – O.D. tube to female thread
p. FIT-1-16.



37 Conversion Union – inch O.D. tube to metric O.D. tube
p. FIT-1-9.



40 Union Elbow – O.D. tube to O.D. tube
p. FIT-1-11.



45 Male Elbow – O.D. tube to male thread
p. FIT-1-20.



47 Swivel Male Elbow – O.D. tube to male thread
p. FIT-1-21.



48 Swivel Female Elbow – O.D. tube to female thread
p. FIT-1-23.



51 Banjo Elbow – O.D. tube to male thread
p. FIT-1-26.

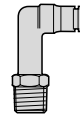

54 Extended Swivel Male Elbow – O.D. tube to male thread
p. FIT-1-22.

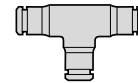

60 Union Tee – O.D. tube
p. FIT-1-12.

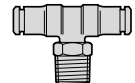

67 Swivel Male Branch Tee – O.D. tube (2) to male thread
p. FIT-1-24.

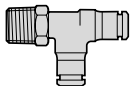

68 Swivel Male Run Tee – O.D. tube (2) to male thread
p. FIT-1-25.

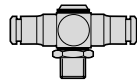

71 Tee banjo O.D. tube (2) to male thread –
p. FIT-1-27.



80 Union Y Connector – O.D. tube
p. FIT-1-13.

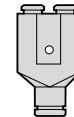

82 Parallel Union Y Connector – O.D. Tube
p. FIT-1-12.

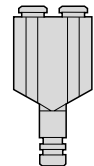

84 Parallel Male Y Connector – O.D. tube to O.D. tube stem
p. FIT-1-13.

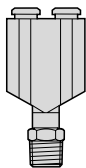

88 Parallel Male Y Swivel Adapter – O.D. tube to male thread
p. FIT-1-26.

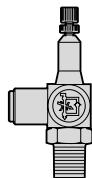

VA0 Right Angle (Banjo) Flow Controls O.D. tube to male thread
p. FIT-3-2.



VB0 Right Angle (banjo) Flow Control
p. FIT-3-3

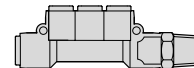

OD6 and 4D6 Manifold – multiple O.D. tube, and multiple O.D. tube to male thread
p. FIT-1-28

Inch Series Push-In Tube Fittings

1/8" to 1/2" Tube Sizes, 10-32 UNF to 1/2" NPT Thread Options

- Reduced assembly and maintenance time.
- Expanded pressure rating.
- Pre-applied thread sealant.
- Silicone free o-rings.
- Nickel plated brass bodies and collets.
- Maximum flows in a reduced size.

Specifications

Fluid: Compressed air, nitrogen, inert and non-combustible gases compatible with materials of construction.

Note: For other types of fluids or compressed gases, please consult factory.

Working Pressure: 29.5" Hg vacuum to 260 psig (750 mm Hg to 18 bar)

Note: Flow Control working pressures: 5 to 150 psig (.3 to 10 bar)

Working Temperature: 0° to 175°F (-20° to 80°C)

See Viton® Option for extended temperature range : 0° to 350°F (-20° to 180°C)

Materials

Body, swivel fitting and collet: Nickel plated brass

O-ring: Silicone free Nitrile

Sealing washer (parallel male threads): Thermoplastic

Tubing: Nylon 11 or 12, Polyurethane (95 durometer or above) and LDPE (Low Density Polyethylene).

Note: Lower durometer polyurethane may be used, however, an internal tube support is required to prevent internal collapse of the tube wall.

Torque figures

Thread Sealant: Precote 5 thread sealant is factory applied to the circumference of tapered male threads.

Thread	Tightening torque ft lbs (Nm)
10-32	.75 – 1 (1-1.4)
1/8"	5.0 – 6.5 (6.9 – 8.8)
1/4"	8.7 – 10.1 (11.8 – 13.7)
3/8"	15.9 – 17.3 (21.6 – 23.5)
1/2"	20.2 – 21.7 (27.4 – 29.4)



Tube O.D.'s and Tube Tolerances

Tube O.D.	O.D. Tube Tolerances	
	Nylon	Polyurethane
1/8" to 1/2" (3 mm to 14 mm)	+0.002" (+0.05 mm) -0.004" (-0.10 mm)	±0.004" (±0.10 mm)

LDPE –Tolerances specified in DIN 73378 or BS54-09/1:1976

Options

Viton® fluoroelastomers can be supplied for chemical compatibility or expanded temperature range requirements. To order fittings with Viton elastomers, add a "V" suffix to the part number.

Example: To order part 12 060 0400 with Viton, add "V" to the end of the number, i.e. 12 060 0400V.

The temperature range for fittings equipped with Viton elastomers is 0° to 350°F (-20° to 180°C)

NOTE: Fittings equipped with 10-32 UNF threads use a molded thermoplastic washer to effect a face seal. The maximum service temperature of this seal is 175°F (80°C). In the case of the 10-32 UNF male thread, a Viton bonded sealing washer is available for extended temperature service. Order part number 48 021 605V and use it in place of the thermoplastic seals provided with fittings incorporating 10-32 UNF male threads. These washers are also suitable for use with M5 (male) Pneufit Adapter fittings, and are supplied in packages of 10.

Typical Dimensions Inches (mm)

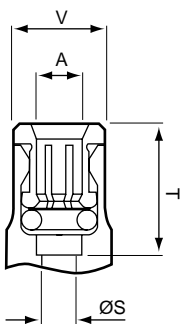

A O.D. Tube	S	T Tubing Stop	V
1/8"	0.09 (2.3)	0.53 (13.5)	0.26 (6.5)
5/32" (4)	0.11 (2.8)	0.55 (14.0)	0.30 (7.5)
3/16"	0.13 (3.4)	0.59 (15.1)	0.38 (9.7)
1/4"	0.17 (4.4)	0.61 (15.5)	0.42 (10.7)
5/16" (8)	0.24 (6.0)	0.65 (16.5)	0.51 (13.0)
3/8"	0.30 (7.6)	0.83 (21.0)	0.59 (15.1)
1/2"	0.38 (9.6)	0.96 (24.3)	0.71 (18.1)

Pneufit C – Composite Fittings Inch



Ø 1/8" to 3/8" O/D Tube



- Releasable grab ring technology combining plastic and brass components for a compact and superior fitting design
- Color coding option available with tamper-resistance feature
- Molded mounting brackets on tube connector designs
- Grey release sleeve indicating inch tube sizes
- Silicone free 'O' ring seals
- Grips soft PU tube
- Reusable 'O' ring seals on parallel threads
- Non - PTFE based thread sealant on tapered threads
- Easy tube insertion for rapid and quick assembly of pneumatic circuits
- Internal hexagon on straight adapters allows assembly in confined spaces
- Reliable and corrosion resistant

Tube sizes

1/8", 5/32", 1/4", 5/16", 3/8" O/D

Warning: The Pneufit C design is not to be used with vehicle air braking or ancillary systems. For push-in fittings suitable for these applications, please refer to the Fleetfit range or contact Technical Sales for assistance

Tube types

Nylon 11 or 12, polyurethane* and other plasticized or unplasticized tubing which conforms to the tolerances specified in DIN 73378, NFE 49-101, ISO / WD 16026, ISO / WD 16627

Copper and stainless steel tube

* Suitable for 85D

Torque figures

Thread sealant is applied to the full circumference of the thread. The recommended tightening torque figures for designs with thread sealant are found in the following table:

Thread	Tightening torque ft lbs (Nm)
1/8"	5.1 – 6.5 (6.9 – 8.8)
1/4"	8.7 – 10.1 (11.8 – 13.7)
3/8"	15.9 – 18.6 (21.6 – 23.5)
1/2"	20.2 – 21.7 (27.4 – 29.4)

Technical data

Medium:

Compressed air

Operating pressure:

Vacuum - 260 psig (18 bar) unless otherwise stated (dependent on tubing specification)

Ambient Temperature:

0° to 175°F (-20° to 80° C)

Materials

Bodies: plastic - PBT, except straight adapters and straight stem adapters

Straight adapters: nickel plated brass

Straight stem adapters: plastic - acetal

Threads: nickel plated brass

Grab ring: stainless steel - BS 1440 Pt 2, grade 301.S21

'O' rings: silicone free nitrile

Thread sealant: non PTFE

Typical dimensions (inches)

A O/D tube	S†	T* Tube stop	V
1/8"	.09	.60	.42
5/32"	.11	.60	.42
1/4"	.17	.67	.51
5/16"	.24	.76	.57
3/8"	.30	.80	.69

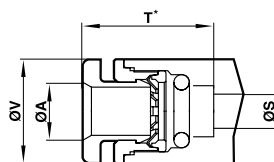

* Dimensions here and in the individual tables refer to the release button in the 'OUT' position

Dimensions here (minimum bore diameter) are common per tube size for all connectors, elbow and tees unless otherwise stated



Features and Benefits

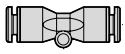

C2020 Straight Connector
- tube to tube
p. FIT-1-8



C2425 Straight Adapter
tube to UNF male
thread
p. FIT-1-15



C2425 Straight Adapter
tube to NPTF thread
p. FIT-1-15.

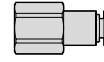

C2426 Female Straight
Adapter tube to female
NPTF thread
p. FIT-1-2.

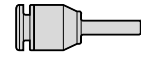

C2023 Straight Stem
Adapter tube to stem
p. FIT-1-10.

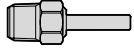

C2415 Straight Stem
Adapter stem to NPTF
male threads
p. FIT-1-18

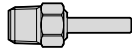

C2115 Straight Stem
Adapter stem to BSPT
male thread
FIT-1-19



C2040 90° Elbow
Connector tube to tube
FIT-1-11



C2447 90° Swivel Elbow
Adapter tube to UNF
male thread
p. FIT-1-22.

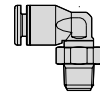

C2447 90° Swivel Elbow
Adapter tube to NPTF
male thread
p. FIT-1-22.

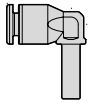

C2043 90° Stem Elbow
Connector tube to stem
p. FIT-1-22.

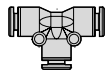

C2060 Tee Connector tube
to tube
p. FIT-1-12.

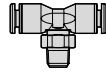

C2467 Swivel Tee Adapter
tube to NPTF male thread
p. FIT-1-24.

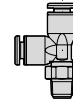

C2468 Male Elbow - O.D.
tube to male thread
p. FIT-1-25.

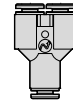

C2082 Parallel Y
Connector tube to tube
p. FIT-1-12.

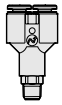

C2488 Parallel Y Adapter
tube to NPTF male thread
p. FIT-1-23.



C2084 Parallel Y Stem
Connector tube to stem
p. FIT-1-13.

Pneufit C construction:
90° swivel elbow adapter

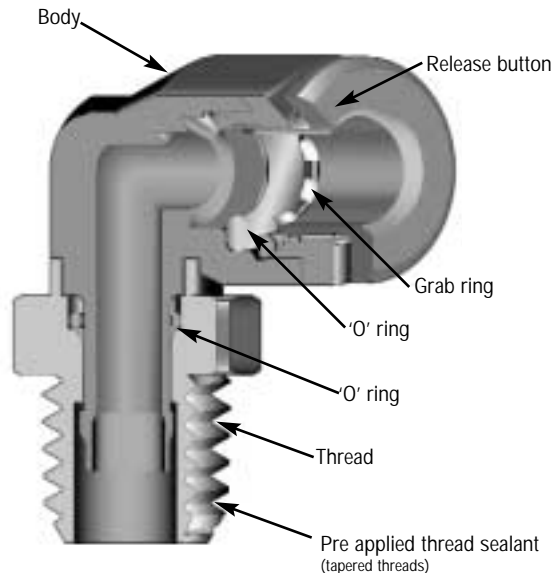



Norgren Pneufit & Pneufit C Inch Push-In Fittings provide a simple means of connecting compressed air products to system piping. They are designed for use with flexible thermoplastic tubing and are available in a wide range of configurations to fit nearly every conceivable application.

Reduced Assembly and Maintenance Time

Norgren Push-In Fittings reduce assembly time by 70 to 80% by eliminating the time consuming insertion of ferrules and wrenching of compression nuts. Also, no tools are required for the insertion or removal of tubing from fittings, simplifying plumbing modifications and repairs.

Reduced Installation Distances

All straight Norgren Push-In Fittings feature internal hexes. Since the wrench is applied internally to the fittings rather than externally, the fittings can be located virtually shoulder to shoulder.

Expanded Pressure Rating

With a pressure operating range of 29.5" Hg vacuum to 260 psig (750 mm Hg vacuum to 18 bar), one fitting covers over 98% of applications, extending the usable range of push-in fittings and reducing both inventory and stocking requirements.

Pre-applied thread sealant

Precote 5, a non-PTFE based thread sealant, is applied to the circumference of all tapered male threads; thermoplastic sealing washers are supplied on all parallel male threads (10-32). This added feature eliminates the necessity of having to seal threads, reducing the possibility of system contamination with PTFE tape. Precote 5 thread sealant has a four year minimum shelf life, connections can be remade into the same port up to six times, it is inert, has a maximum service temperature of 350°F (180°C), and since it does not contain PTFE is accepted by the Pharmaceutical and Tobacco Industries.

Silicone Free O-rings

Silicone will migrate to product surfaces during the finishing process creating unsightly "fish eyes" that require costly rework. All O-rings used in Norgren fittings are silicone free, a mandatory requirement of both the automotive and product finishing industry.

Nickel Plated Brass Bodies and Collets

Nickel plating gives Pneufit a uniform stainless steel like appearance, does not tarnish like brass and provides an added degree of corrosion resistance.

Size Identification

All collets or release buttons are marked with the O.D. tube size in fractional inch, millimeters, or both, providing instant tube size identification. Stem fittings have two grooves for inch and one groove for metric.

Anti-kink design (Pneufit only)

Pneufit Collets are designed to rotate freely within the fitting's body. This eliminates the troublesome kinking and twisting that can occur when tubes are retained in a rigid connection.

Maximum Flows in a Reduced Size

Maximized internal bores provide optimal flows, while forged brass bodies deliver maximum strength, reduced weights (over extruded types) and reduced envelope size.

Conveniently Packaged

Stocking and inventory are simplified because Push-In Fittings are packaged in boxes of ten, with product number, shape and sizes prominently displayed on the box.

Internationally significant part numbering system

A numbering system that identifies all aspects of the product is a standard feature, with support and availability provided world wide by a network of NORGREN distributors.

Method of Assembly

Pneufit

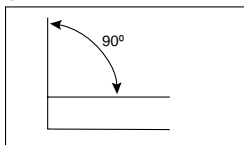

1. Ensure that the tube end is cut square and is free of burrs.

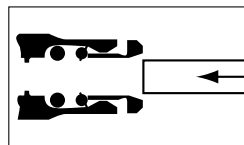

2. Push the tube through the collet into the fitting.

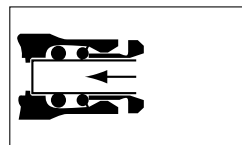

3. Continue pushing the tube (firmly) through the O-ring until it bottoms on the tube stop, then pull back

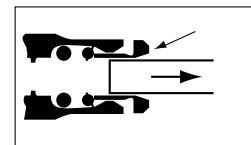

4. To disconnect, push the tube into the fitting until it bottoms on the tube stop. Then while holding down the collet, withdraw the tube.

Pneufit C



1. Ensure that the end of the tube is cut square and is free from burrs.

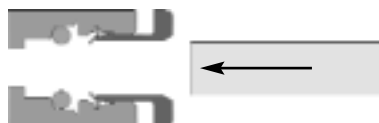

2. Push the tube through the release button and grab ring into the fitting.



3. Push the tube firmly through the 'O' ring until it bottoms on the tube stop then pull back.

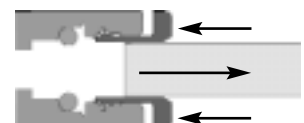

4. To disconnect, push the tube into the fitting, hold down the release button and withdraw the tube.



Inch Series Push-In Fittings

Dimensions in Inches (mm)

Pneufit Union

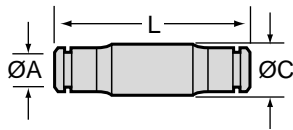

A Tube O.D.	Part Number	L	C
1/8"	12 020 0100	1.15 (29.3)	0.35 (9.0)
1/8" to 1/4"*	12 020 0104	1.22 (31.0)	0.47 (12.0)
5/32"	12 020 0200	1.17 (29.8)	0.39 (10.0)
3/16"	12 020 0300	1.26 (31.9)	0.43 (11.0)
1/4"	12 020 0400	1.28 (32.4)	0.47 (12.0)
5/16"	12 020 0500	1.35 (34.4)	0.55 (14.0)
3/8"	12 020 0600	1.71 (43.4)	0.67 (17.0)
1/2"	12 020 0700	1.98 (50.4)	0.81 (20.5)

* Reducing union with 1/8" and 1/4" connections

Pneufit C Union

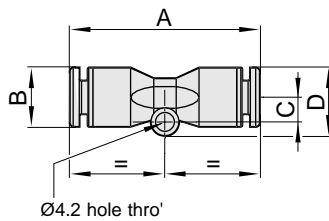

O.D. Tube	Part Number	A	B	C	D
1/8"	C20200100	1.34 (33.5)	.43 (10.7)	.20 (5.0)	.54 (13.6)
5/32"	C20200200	1.34 (33.5)	.43 (10.7)	.20 (5.0)	.54 (13.6)
1/4"	C20200400	1.56 (39.0)	.52 (12.9)	.24 (6.0)	.63 (15.7)
5/16"	C20200500	1.74 (43.5)	.58 (14.5)	.28 (7.0)	.70 (17.5)
3/8"	C20200600	1.92 (48.0)	.70 (17.4)	.32 (8.1)	.80 (20.1)



Pneufit Conversion Union (Inch tube to mm tube)

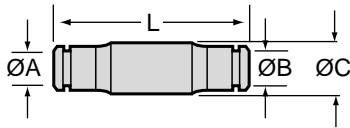

A Inch O.D.	B mm O.D.	Part Number	L	C
5/32	4	12 020 0200	1.17 (29.8)	0.39 (10.0)
3/16	5	12 037 0305	1.26 (32.0)	0.43 (11.0)
1/4	6	12 037 0406	1.28 (32.5)	0.47 (12.0)
5/16	8	12 020 0500	1.35 (34.4)	0.55 (14.0)
3/8	10	12 037 0610	1.71 (43.4)	0.67 (17.0)
1/2	12	12 037 0712	1.98 (50.3)	0.81 (20.5)

Pneufit Double Male Union (Brass)

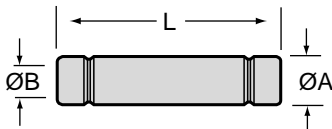

A Stem O.D.	Part Number	B	L
1/8"	12 022 0100	0.09 (2.4)	1.18 (30.0)
5/32"	12 022 0200	0.13 (3.4)	1.19 (30.2)
3/16"	12 022 0300	0.16 (4.0)	1.31 (33.3)
1/4"	12 022 0400	0.24 (6.0)	1.34 (34.0)
5/16"	12 022 0500	0.30 (7.6)	1.42 (36.1)
3/8"	12 022 0600	0.38 (9.6)	1.77 (45.0)
1/2"	12 022 0700	0.45 (11.5)	2.05 (52.0)



Inch Series Push-In Fittings

Dimensions in Inches (mm)

Pneufit Tube End Expander/Reducer

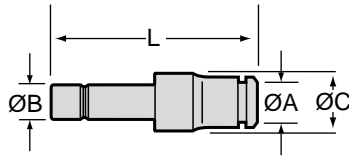

A Tube O.D.	B Stem O.D.	Part Number	L	C
Reducing				
1/8"	5/32"	12 023 0201	1.22 (31.0)	0.35 (9.0)
	1/4"	12 023 0401	1.30 (33.0)	0.35 (9.0)
5/32"	1/4"	12 023 0402	1.34 (34.0)	0.39 (10.0)
	5/16"	12 023 0502	1.22 (31.0)	0.39 (10.0)
	3/8"	12 023 0602	1.22 (31.0)	0.47 (12.0)
3/16"	1/4"	12 023 0403	1.38 (35.0)	0.43 (11.0)
	5/16"	12 023 0503	1.30 (33.0)	0.43 (11.0)
1/4"	5/16"	12 023 0504	1.46 (37.0)	0.47 (12.0)
	3/8"	12 023 0604	1.50 (38.0)	0.47 (12.0)
	1/2"	12 023 0704	1.38 (35.0)	0.55 (14.0)
5/16"	3/8"	12 023 0605	1.69 (43.0)	0.55 (14.0)
	1/2"	12 023 0705	1.65 (42.0)	0.55 (14.0)
3/8"	1/2"	12 023 0706	1.97 (50.0)	0.67 (17.0)
Expanding				
1/4"	1/8"	12 023 0104	1.34 (34.0)	0.47 (12.0)
	5/32"	12 023 0204	1.38 (35.0)	0.47 (12.0)
	3/16"	12 023 0304	1.40 (35.5)	0.47 (12.0)

Pneufit C Tube End Expander/Reducer

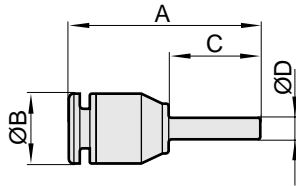

O.D. Tube	Stem	Part Number	A	B	D	E
1/8"	5/32"	C20230201	1.34 (33.5)	.43 (10.7)	.68 (17)	.16 (4.0)
1/8"	1/4"	C20230401	1.42 (35.5)	.43 (10.7)	.76 (19)	.25 (6.25)
5/32"	1/4"	C20230402	1.42 (35.5)	.43 (10.7)	.76 (19)	.25 (6.25)
5/32"	5/16"	C20230502	1.42 (35.5)	.43 (10.7)	.84 (21)	.32 (8.0)
5/32"	3/8"	C20230602	1.48 (37.0)	.43 (10.7)	.96 (24)	.40 (10.0)
1/4"	1/8"	C20230104	1.42 (35.5)	.52 (13.0)	.68 (17)	.13 (3.15)
1/4"	5/32"	C20230204	1.42 (35.5)	.52 (13.0)	.68 (17)	.16 (4.0)
1/4"	5/16"	C20230504	1.60 (40.0)	.52 (13.0)	.84 (21)	.32 (8.0)
1/4"	3/8"	C20230604	1.64 (41.0)	.52 (13.0)	.96 (24)	.40 (10.0)
1/4"	1/2"	C20230704	1.64 (41.0)	.52 (13.0)	1.10 (27.5)	.51 (12.65)
5/16"	3/8"	C20230605	1.82 (45.5)	.58 (14.5)	.96 (24)	.40 (10.0)
5/16"	1/2"	C20230705	1.98 (49.5)	.58 (14.5)	1.10 (27.5)	.51 (12.65)
3/8"	1/2"	C20230706	2.04 (51.0)	.70 (17.5)	1.10 (27.5)	.51 (12.65)

Inch Series Push-In Fittings

Dimensions in Inches (mm)



Pneufit Bulkhead Union

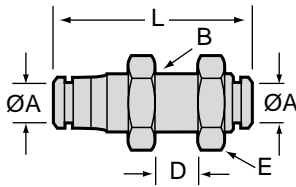

A Tube O.D.	Part Number	B Metric Thread	Panel Hole ϕ	E A/F	D Max	L
1/8"	12 029 0100	M10 x 1.0	0.42 (10.5)	0.55 (14.0)	0.47 (12)	1.15 (29.3)
5/32"	12 029 0200	M10 x 1.0	0.42 (10.5)	0.55 (14.0)	0.47 (12.0)	1.18 (30.0)
3/16"	12 029 0300	M12 x 1.0	0.49 (12.5)	0.67 (17.0)	0.55 (14.0)	1.26 (32.0)
1/4"	12 029 0400	M14 x 1.5	0.57 (14.5)	0.75 (19.0)	0.59 (15.0)	1.38 (35.0)
5/16"	12 029 0500	M16 x 1.5	0.65 (16.5)	0.87 (22.0)	0.63 (16.0)	1.42 (36.0)
3/8"	12 029 0600	M20 x 1.5	0.81 (20.5)	1.06 (27.0)	0.55 (14.0)	1.69 (43.0)
1/2"	12 029 0700	M24 x 1.5	0.96 (24.5)	1.18 (30.0)	0.59 (15.0)	1.97 (50.0)

Pneufit Union Elbow

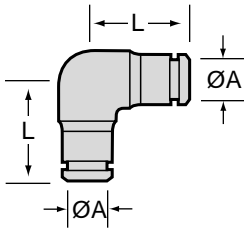

A Tube O.D.	Part Number	L
1/8"	12 040 0100	0.65 (16.4)
5/32"	12 040 0200	0.67 (17.0)
3/16"	12 040 0300	0.72 (18.4)
1/4"	12 040 0400	0.77 (19.6)
5/16"	12 040 0500	0.84 (21.3)
3/8"	12 040 0600	1.05 (26.7)
1/2"	12 040 0700	1.25 (31.7)

Pneufit C Union Elbow

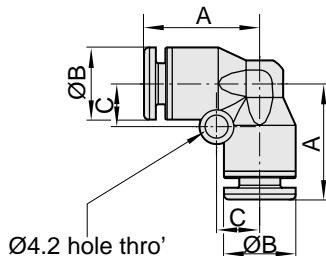

O.D. Tube	Part Number	A	B	C
1/8"	C20400100	.72 (18.0)	.43 (10.7)	.26 (6.5)
5/32"	C20400200	.72 (18.0)	.43 (10.7)	.26 (6.5)
1/4"	C20400400	.84 (21.0)	.52 (12.9)	.31 (7.7)
5/16"	C20400500	1.00 (25.0)	.58 (14.5)	.29 (7.25)
3/8"	C20400600	1.10 (27.5)	.70 (17.4)	.33 (8.35)



Inch Series Push-In Fittings

Dimensions in Inches (mm)

Pneufit Union Tee

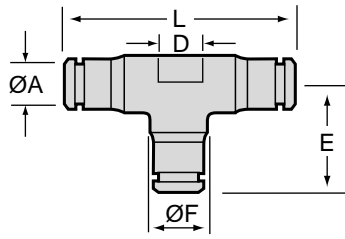

A Tube O.D.	Part Number	C	D A/F	E	F	L
1/8"	12 060 0100	0.26 (6.5)	0.20 (5.0)	0.63 (15.9)	0.32 (8.1)	1.26 (32.0)
5/32"	12 060 0200	0.30 (7.5)	0.28 (7.0)	0.67 (16.9)	0.40 (10.1)	1.34 (34.0)
3/16"	12 060 0300	0.38 (9.7)	0.28 (7.0)	0.72 (18.4)	0.44 (11.1)	1.44 (36.6)
1/4"	12 060 0400	0.42 (10.7)	0.31 (8.0)	0.77 (19.6)	0.48 (12.1)	1.54 (39.2)
5/16"	12 060 0500	0.50 (12.7)	0.43 (11.0)	0.84 (21.3)	0.56 (14.3)	1.68 (42.6)
3/8"	12 060 0600	0.59 (15.1)	0.52 (13.3)	1.05 (26.7)	0.67 (17.1)	2.10 (53.4)
1/2"	12 060 0700	0.71 (18.1)	0.63 (16.0)	1.25 (31.7)	0.81 (20.6)	2.50 (63.4)

Pneufit C Union Tee

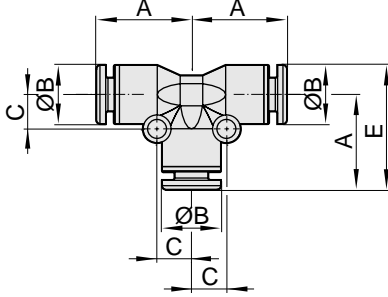

O.D. Tube	Part Number	A	B	C	E
1/8"	C20600100	.72 (18.0)	.43 (10.7)	.26 (6.5)	.94 (23.5)
5/32"	C20600200	.72 (18.0)	.43 (10.7)	.26 (6.5)	.94 (23.5)
1/4"	C20600400	.84 (21.0)	.52 (12.9)	.31 (7.7)	1.10 (27.5)
5/16"	C20600500	1.00 (25.0)	.58 (14.5)	.29 (7.25)	1.30 (32.5)
3/8"	C20600600	1.10 (27.5)	.70 (17.4)	.33 (8.35)	1.46 (36.5)

Pneufit Parallel Union "Y" Connector*

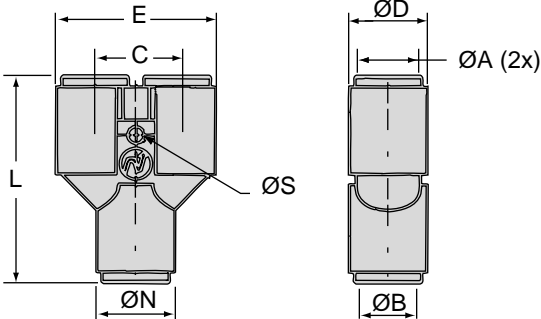

A Tube O.D.	B Tube O.D.	Part Number	C	ØD	E	L	ØN	ØS**
5/32"	5/32"	12 082 0200	0.43 (11.0)	0.30 (7.5)	0.87 (22.0)	1.34 (34.0)	0.43 (11.0)	0.13 (3.2)
5/32"	1/4"	12 082 0402	0.55 (14.0)	0.43 (11.0)	1.06 (27.0)	1.50 (38.2)	0.51 (13.0)	0.13 (3.2)
1/4"	1/4"	12 082 0400	0.55 (14.0)	0.43 (11.0)	1.06 (27.0)	1.51 (38.4)	0.51 (13.0)	0.13 (3.2)
5/16"	5/16"	12 082 0500	0.63 (16.0)	0.51 (13.0)	1.22 (31.0)	1.59 (40.4)	0.59 (15.0)	0.13 (3.2)

*Body Material: Thermoplastic
** Mounting hole

Pneufit C Parallel Union "Y" Connector*

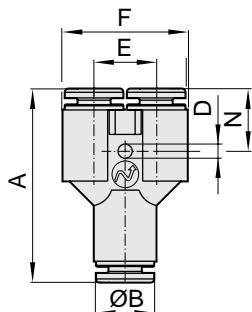

O.D. Tube	O.D. Tube	O.D. Tube	Part Number	A	B	D	E	F	N
5/32"	5/32"	5/32"	C20820200	1.64 (41.0)	.44 (11.0)	.13 (3.2)	.44 (11.0)	.88 (22.0)	.52 (13.0)
1/4"	1/4"	1/4"	C20820400	1.75 (43.8)	.56 (14.0)	.13 (3.2)	.56 (14.0)	1.12 (28.0)	.57 (14.25)
5/16"	5/16"	5/16"	C20820500	1.87 (46.7)	.60 (15.0)	.13 (3.2)	.64 (16.0)	1.24 (31.0)	.60 (14.90)
1/4"	5/32"	5/32"	C20820604	1.77 (44.3)	.56 (14.0)	.13 (3.2)	.56 (14.0)	1.12 (28.0)	.58 (14.50)



Pneufit Parallel Male "Y" Connector*

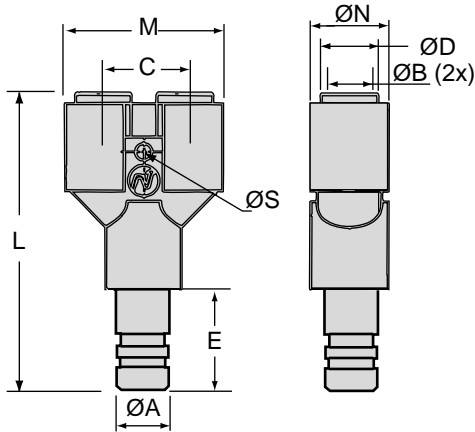

A Stem O.D.	B Tube O.D.	Part Number	C	ØD	E	L	M	ØN	ØS**
5/32"	5/32"	12 084 0202	0.43 (11.0)	0.30 (7.5)	0.71 (18.0)	2.05 (52.0)	0.89 (22.5)	0.45 (11.5)	0.13 (3.2)
1/4"	5/32"	12 084 0402	0.43 (11.0)	0.30 (7.5)	0.73 (18.5)	2.23 (56.7)	0.89 (22.5)	0.45 (11.5)	0.13 (3.2)
1/4"	1/4"	12 084 0404	0.55 (14.0)	0.43 (11.0)	0.73 (18.5)	2.23 (56.7)	1.10 (28.0)	0.55 (14.0)	0.13 (3.2)
5/16"	5/16"	12 084 0505	0.63 (16.0)	0.51 (13.0)	0.77 (19.5)	2.36 (59.9)	1.26 (32.0)	0.63 (16.0)	0.13 (3.2)

*Body Material: Thermoplastic

** Mounting hole

Pneufit C Parallel Male "Y" Connector*

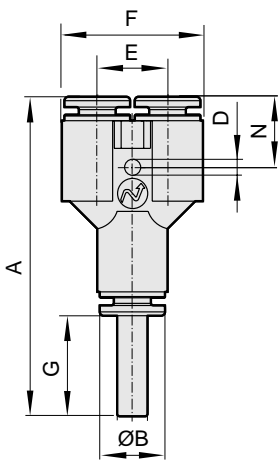

O.D.		Part Number	A	B	D	E	F	G	N
Tube	Stem								
5/32"	5/32"	C20840202	2.32 (58.0)	.46 (11.5)	.12 (2.95)	.44 (11.0)	.16 (4.0)	.52 (13.0)	.68 (17.0)
5/32"	1/4"	C20840402	2.40 (60.0)	.46 (11.5)	.12 (2.95)	.44 (11.0)	.25 (6.25)	.52 (13.0)	.76 (19.0)
1/4"	1/4"	C20840404	2.52 (63.0)	.46 (14.0)	.13 (3.2)	.56 (14.0)	.25 (6.25)	.57 (14.25)	.77 (19.2)
5/16"	5/16"	C20840505	2.72 (68.0)	.64 (16.0)	.13 (3.2)	.64 (16.0)	.32 (8.0)	.60 (14.90)	.85 (21.3)

Union Y Connector*

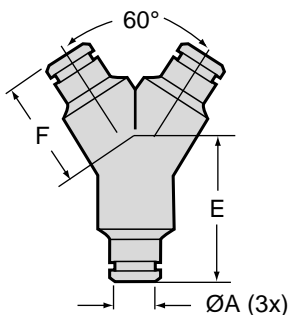

A Tube O.D.	Part Number	E	F
5/32"	12 080 0200	0.63 (15.9)	0.74 (18.9)

*Body Material: Nickel plated Brass



Inch Series Push-In Fittings

Dimensions in Inches (mm)

Pneufit Male Connector

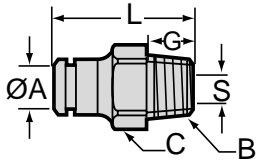
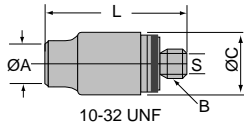

All straight male connectors have an internal hex for the use of an Allen Wrench to allow the fitting to be mounted in any position. This also permits close porting not possible with a standard open end or socket wrench.

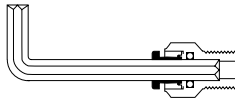

A Tube O.D.	B NPT or UNF Thread	Part Number	C A/F	G	L	S Hex
1/8"	10-32 UNF	12 425 0110	0.35 (9)	0.20 (5.0)	0.79 (20.0)	3/32"
	1/16	12 425 0116	3/8"	0.37 (9.5)	0.80 (20.4)	3/32"
	1/8	12 425 0118	7/16"	0.37 (9.5)	0.67 (16.9)	3/32"
	1/4	12 425 0128	9/16"	0.56 (14.3)	0.95 (24.2)	3/32"
5/32"	10-32 UNF	12 425 0210	0.35 (9)	0.20 (5.0)	0.85 (21.5)	3/32"
	1/8	12 425 0218	7/16"	0.37 (9.5)	0.89 (22.7)	1/8"
	1/4	12 425 0228	9/16"	0.56 (14.3)	1.04 (26.5)	1/8"
3/16"	1/8	12 425 0318	7/16"	0.37 (9.5)	0.96 (24.5)	5/32"
	1/4	12 425 0328	9/16"	0.56 (14.3)	1.04 (26.3)	5/32"
1/4"	10-32 UNF	12 425 0410	0.43 (11.0)	0.20 (5.0)	0.94 (24.0)	3/32"
	1/8	12 425 0418	7/16"	0.37 (9.5)	0.98 (25.0)	5/32"
	1/4	12 425 0428	9/16"	0.56 (14.3)	1.11 (28.3)	5/32"
	3/8	12 425 0438	11/16"	0.56 (14.3)	1.07 (27.2)	3/16"
5/16"	1/8	12 425 0518	1/2"	0.37 (9.5)	1.12 (28.5)	3/16"
	1/4	12 425 0528	9/16"	0.56 (14.3)	1.23 (31.3)	1/4"
	3/8	12 425 0538	11/16"	0.56 (14.3)	1.13 (28.8)	1/4"
3/8"	1/8	12 425 0618	11/16"	0.37 (9.5)	1.32 (33.5)	3/16"
	1/4	12 425 0628	11/16"	0.56 (14.3)	1.47 (37.3)	1/4"
	3/8	12 425 0638	11/16"	0.56 (14.3)	1.41 (35.8)	5/16"
	1/2	12 425 0648	7/8"	0.75 (19.1)	1.45 (36.8)	5/16"
1/2"	1/4	12 425 0728	7/8"	0.56 (14.3)	1.67 (42.3)	1/4"
	3/8	12 425 0738	7/8"	0.56 (14.3)	1.63 (41.3)	3/8"
	1/2	12 425 0748	7/8"	0.75 (19.1)	1.70 (43.3)	3/8"

Inch Series Push-In Fittings

Dimensions in Inches (mm)



Pneufit C Male Connector

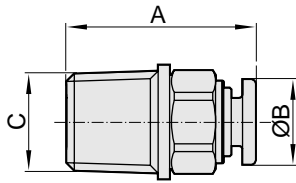

O.D. Tube	NPT Thread	Part Number	A	B	C
1/8"	1/16"	C24250116	.87 (21.7)	.43 (10.7)	1/16"
1/8"	1/8"	C24250118	.81 (20.2)	.43 (10.7)	1/8"
1/8"	1/4"	C24250128	1.03 (25.7)	.43 (10.7)	1/4"
5/32"	1/8"	C24250218	.85 (21.2)	.43 (10.7)	1/8"
5/32"	1/4"	C24250228	1.03 (25.7)	.43 (10.7)	1/4"
1/4"	1/8"	C24250418	1.04 (26.1)	.52 (12.9)	1/8"
1/4"	1/4"	C24250428	1.10 (27.6)	.52 (12.9)	1/4"
1/4"	3/8"	C24250438	1.10 (27.6)	.52 (12.9)	3/8"
5/16"	1/8"	C24250518	1.18 (29.5)	.58 (14.5)	1/8"
5/16"	1/4"	C24250528	1.18 (29.5)	.58 (14.5)	1/4"
5/16"	3/8"	C24250538	1.10 (27.5)	.58 (14.5)	3/8"
3/8"	1/8"	C24250618	1.24 (31.1)	.70 (17.6)	1/8"
3/8"	1/4"	C24250628	1.38 (34.6)	.70 (17.6)	1/4"
3/8"	3/8"	C24250638	1.20 (30.1)	.70 (17.6)	3/8"
3/8"	1/2"	C24250648	1.42 (35.6)	.70 (17.6)	1/2"

Pneufit C Male Connector

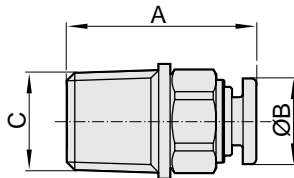

O.D. Tube	NPT Thread	Part Number	A	B	C
1/8"	10-32	C24250110	.85 (21.2)	.43 (10.7)	.42 (10.6)
5/32"	10-32	C24250210	.85 (21.2)	.43 (10.7)	.42 (10.6)
1/4"	10-32	C24250410	.96 (24.1)	.52 (12.9)	.50 (12.6)

NOTE: ISO G straights to be added 3rd quarter of 2001

Description	Part Number
Straight Adaptor 1/4 O.D. Tube x M5	122250405
Straight Adaptor 1/4 O.D. Tube x 1/8 ISO G	122250418
Straight Adaptor 1/4 O.D. Tube x 1/4 ISO G	122250428
Straight Adaptor 3/8 O.D. Tube x 1/4 ISO G	122250628
Straight Adaptor 3/8 O.D. Tube x 3/8 ISO G	122250638
Straight Adaptor 1/2 O.D. Tube x 3/8 ISO G	122250738
Straight Adaptor 1/2 O.D. Tube x 1/2 ISO G	122250748
Swivel Elbow 1/4 O.D. Tube x M5	122470405
Swivel Elbow 1/4 O.D. Tube x 1/8 ISO G	122470418
Swivel Elbow 1/4 O.D. Tube x 1/4 ISO G	122470428
Swivel Elbow 3/8 O.D. Tube x 1/4 ISO G	122470628
Swivel Elbow 3/8 O.D. Tube x 3/8 ISO G	122470638
Swivel Elbow 1/2 O.D. Tube x 3/8 ISO G	122470738
Swivel Elbow 1/2 O.D. Tube x 1/2 ISO G	122470748



Inch Series Push-In Fittings

Dimensions in Inches (mm)

Pneufit Male Connector - Conversion (MM O.D. Tube to NPTF [Male] Thread)

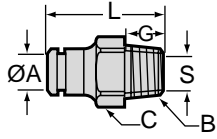

All straight male connectors have an internal hex for the use of an Allen Wrench to allow the fitting to be mounted in any position. This also permits close porting not possible with a standard or open end socket wrench.

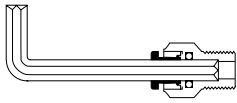

NOTE: For 4 mm tube use 5/32" fittings and for 8 mm tube use 5/16" fittings

A Tube O.D.	B NPT Thread	Part Number	C A/F	G	L	S Hex
4	10-32	12 425 0210	.35 (9.0)	.20 (5.0)	.85 (21.5)	3/32"
	1/8	12 425 0218	7/16" (11.1)	.37 (9.5)	.89 (22.7)	1/8"
	1/4	12 425 0228	9/16" (14.3)	.56 (14.3)	1.04 (26.5)	1/8"
5	1/8	10 425 0518	7/16" (11.1)	0.37 (9.5)	0.96 (24.5)	5/32"
	1/4	10 425 0528	9/16" (14.3)	0.56 (14.3)	1.04 (26.3)	5/32"
6	10-32	10 425 0610	0.43 (11.0)	0.20 (5.0)	0.94 (24.0)	3/32"
	1/8	10 425 0618	7/16" (11.1)	0.37 (9.5)	0.98 (25.0)	5/32"
	1/4	10 425 0628	9/16" (14.3)	0.56 (14.3)	1.11 (28.3)	5/32"
	3/8	10 425 0638	11/16" (17.5)	0.56 (14.3)	1.07 (27.2)	5/32"
8	1/8	12 425 0518	1/2" (12.7)	.37 (9.5)	1.12 (28.5)	3/16"
	1/4	12 425 0528	9/16" (14.3)	.56 (14.3)	1.23 (31.3)	1/4"
	3/8	12 425 0538	11/16" (17.5)	.56 (14.3)	1.13 (28.8)	1/4"
10	1/8	10 425 1018	11/16" (17.5)	0.37 (9.5)	1.32 (33.5)	3/16"
	1/4	10 425 1028	11/16" (17.5)	0.56 (14.3)	1.47 (37.3)	1/4"
	3/8	10 425 1038	11/16" (17.5)	0.56 (14.3)	1.41 (35.8)	5/16"
	1/2	10 425 1048	7/8" (22.2)	0.75 (19.0)	1.45 (36.8)	5/16"
12	1/4	10 425 1228	7/8" (22.2)	0.56 (14.3)	1.67 (42.3)	9/32"
	3/8	10 425 1238	7/8" (22.2)	0.56 (14.3)	1.63 (41.3)	13/32"
	1/2	10 425 1248	7/8" (22.2)	0.75 (19.0)	1.70 (43.3)	13/32"

Pneufit Female Bulkhead Connector

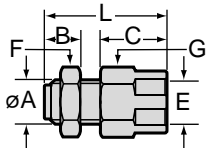

A Tube O.D.	E NPT Female	Part Number	L	B	C	D Metric Thread	F A/F	G A/F	Panel Hole Ø
1/4"	1/4	12 432 0428	1.50 (38.2)	0.24 (6.0)	0.83 (21.0)	M14 x15	0.75 (19)	0.75 (19)	0.57 (14.6) 0.56 (14.2)
3/8"	1/4	12 432 0628	1.56 (39.7)	0.43 (11.0)	0.65 (16.5)	M20 x15	1.06 (27)	0.94 (24)	0.81 (20.6) 0.80 (20.2)



Pneufit Male Connector - Conversion (Inch O.D. Tube to ISO R [Male] Thread)

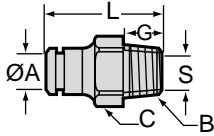

All straight male connectors have an internal hex for the use of an Allen Wrench to allow the fitting to be mounted in any position. This also permits close porting not possible with a standard or open end socket wrench.

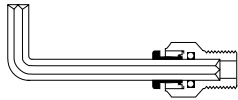

A Tube O.D.	B ISO R Thread	Part Number	C A/F	G	L	S Hex
1/8"	1/8	12 125 0118	0.39 (10.0)	0.30 (7.7)	0.79 (20.0)	— (2.5)
	1/4	12 125 0128	0.55 (14.0)	0.44 (11.1)	0.89 (22.5)	— (2.5)
5/32"	1/8	10 125 0418	0.39 (10.0)	0.30 (7.7)	0.81 (20.5)	— (3.0)
	1/4	10 125 0428	0.55 (14.0)	0.44 (11.1)	0.91 (23.0)	— (3.0)
1/4"	1/8	12 125 0418	0.43 (11)	0.30 (7.7)	0.91 (23.2)	— (4.0)
	1/4	12 125 0428	0.55 (14)	0.44 (11.1)	0.99 (25.2)	— (4.0)
	3/8	12 125 0438	0.67 (17)	0.50 (12.7)	1.01 (25.7)	— (4.0)
5/16"	1/8	10 125 0818	0.51 (13.0)	0.30 (7.7)	1.05 (26.7)	— (5.0)
	1/4	10 125 0828	0.55 (17.0)	0.44 (12.7)	1.11 (27.2)	— (6.0)
	3/8	10 125 0838	0.67 (17.0)	0.50 (12.7)	1.07 (27.2)	— (6.0)
3/8"	1/8	12 125 0618	0.67 (17.0)	0.30 (7.7)	1.25 (31.7)	— (5.0)
	1/4	12 125 0628	0.67 (17.0)	0.44 (11.1)	1.35 (34.2)	— (7.0)
	3/8	12 125 0638	0.67 (17.0)	0.50 (12.7)	1.35 (34.2)	— (8.0)
	1/2	12 125 0648	0.87 (22.0)	0.63 (15.9)	1.33 (33.7)	— (8.0)
1/2"	1/4	12 125 0728	0.87 (22.0)	0.44 (11.1)	1.54 (39.2)	— (7.0)
	3/8	12 125 0738	0.87 (22.0)	0.50 (12.7)	1.56 (39.7)	— (10.0)
	1/2	12 125 0748	0.87 (22.0)	0.63 (15.9)	1.58 (40.2)	— (10.0)

Pneufit Self Sealing (Checked) Connector (Inch tube to NPT)

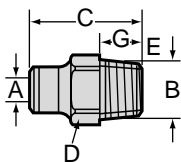

A Tube O.D.	B NPT Thread	Part Number	C	D A/F	G
5/32"	1/8	12 424 0218	1.00 (25.5)	0.43 (11)	0.37 (9.5)
1/4"	1/8	12 424 0418	1.09 (27.6)	0.43 (11)	0.37 (9.5)
1/4"	1/4	12 424 0428	1.09 (27.6)	0.55 (14)	0.56 (14.3)
5/16"	1/4	12 424 0528	1.29 (32.7)	0.55 (14)	0.56 (14.3)

Operation: Insertion of a tube into the push-in end ("A") of the fitting compresses a spring, and unseats the plunger and seal assembly. In this state (tube inserted), flow is allowed through the fitting.

Removal of the tubing from the fitting allows the spring to extend, seating the plunger seal. When pressure is applied to the system, the plunger assembly seals off the push-in end of the fitting, allowing the system to remain pressurized.

Note: Remember to depressurize the system before inserting or removing tubing from this or any other Pneufit.



Inch Series Push-In Fittings

Dimensions in Inches (mm)

Straight stem adapters allow use of Standard Inch (12-Series) and Standard Metric (10-Series) Pneufit Push-in tube unions to create nearly any configuration of Swivel Adapter tube fitting. Various combinations of these products in conjunction with the conversion fitting straight stem adapters are shown at right, creating an entire spectrum of inch O.D. tube to ISO R and MM O.D. tube to NPTF (male) swivel male elbows, swivel male branch and run tees.

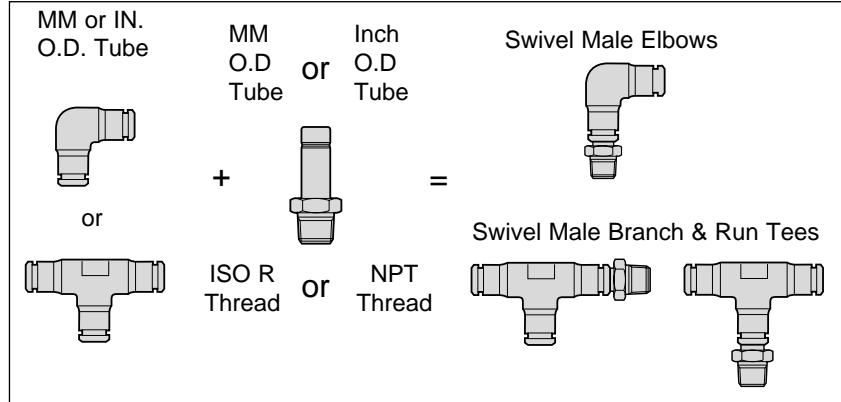

Pneufit Stem Adapter

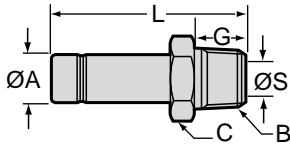

CAUTION: Straight Stem Adapters should not be used in conjunction with other union type fittings in applications where vibration is present, nor should they be used as “quick disconnects” as the mating nickel plated brass surfaces may wear over time causing eventual failure of the connection.

A Tube O.D.	B NPT Thread	Part Number	C A/F	G	L	S Hex
5/32"	10-32 UNF	12 415 0210	5/16"	0.20 (5.0)	1.14 (29.0)	0.08 (2.0)
	1/8	12 415 0218	7/16"	0.37 (9.5)	1.25 (31.8)	0.08 (2.0)
	1/4	12 415 0228	9/16"	0.56 (14.3)	1.45 (36.8)	0.08 (2.0)
1/4"	1/8	12 415 0418	7/16"	0.37 (9.5)	1.33 (33.8)	0.16 (4.0)
	1/4	12 415 0428	9/16"	0.56 (14.3)	1.11 (28.6)	5/32" (4.0)
5/16"	1/8	12 415 0518	7/16"	0.37 (9.5)	1.37 (34.8)	0.19 (5.0)
	1/4	12 415 0528	9/16"	0.56 (14.3)	1.56 (39.6)	0.19 (5.0)
3/8"	1/4	12 415 0628	9/16"	0.56 (14.3)	1.82 (46.2)	0.30 (7.6)
	3/8	12 415 0638	11/16"	0.56 (14.3)	1.82 (46.2)	0.30 (7.6)
1/2"	3/8	12 415 0738	11/16"	0.56 (14.3)	1.95 (49.5)	0.35 (9.0)
	1/2	12 415 0748	7/8"	0.75 (19.0)	2.15 (54.6)	0.35 (9.0)

Pneufit C Stem Adapter

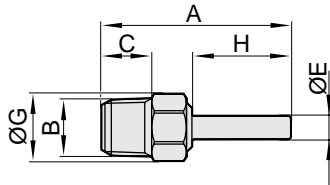

NPT Stem Thread		Part Number	A	B	C	E	G	H
5/32"	10-32	C24150210	1.22 (30.5)	10-32	.17 (4.3)	.16 (4.0)	.44 (11.0)	.68 (17.0)
5/32"	1/8	C24150218	1.32 (33.0)	1/8"	.38 (9.5)	.16 (4.0)	.49 (12.3)	.68 (17.0)
5/32"	1/4	C24150228	1.56 (39.0)	1/4"	.57 (14.25)	.16 (4.0)	.63 (15.75)	.68 (17.0)
1/4"	1/8	C24150418	1.42 (35.5)	1/8"	.38 (9.5)	.25 (6.25)	.49 (12.3)	.76 (19.0)
1/4"	1/4	C24150428	1.64 (41.0)	1/4"	.57 (14.25)	.25 (6.25)	.63 (15.75)	.76 (19.0)
5/16"	1/4	C24150528	1.68 (42.0)	1/4"	.57 (14.25)	.32 (8.0)	.63 (15.75)	.86 (20.0)
3/8"	1/4	C24150628	1.84 (46.0)	1/4"	.57 (14.25)	.40 (10.0)	.63 (15.75)	.96 (24.0)
3/8"	3/8	C24150638	1.88 (47.0)	3/8"	.57 (14.25)	.40 (10.0)	.74 (18.5)	.96 (24.0)
1/2"	3/8	C24150738	2.04 (51.0)	3/8"	.57 (14.25)	.51 (12.65)	.84 (21.0)	1.10 (27.5)
1/2"	1/2	C24150748	2.30 (57.5)	1/2"	.76 (19.05)	.51 (12.65)	.97 (24.35)	1.10 (27.5)



Pneufit Stem Adapter (MM O.D. Stem to NPT [Male] Thread)

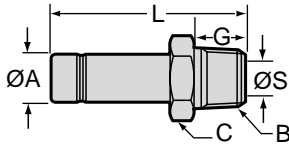

CAUTION: Straight Stem Adapters should not be used in conjunction with other union type fittings in applications where vibration is present, nor should they be used as "quick disconnects" as the mating nickel plated brass surfaces may wear over time causing eventual failure of the connection.

A Stem O.D.	B NPT Thread	Part Number	C A/F	G	L	S
4	1/8	12 415 0218	(11.1) 7/16"	9.5 (.37)	31.8 (1.25)	2.1 (.08)
	1/4	12 415 0228	(14.3) 9/16"	14.3 (.56)	36.7 (1.44)	2.1 (.08)
5	1/8	10 415 0518	(11.1) 7/16"	9.5 (.37)	33.3 (1.31)	3.2 (.13)
	1/4	10 415 0528	(14.3) 9/16"	14.3 (.56)	38.2 (1.50)	3.2 (.13)
6	1/8	10 415 0618	(11.1) 7/16"	9.5 (.37)	33.7 (1.33)	4.0 (.16)
	1/4	10 415 0628	(14.3) 9/16"	14.3 (.56)	38.6 (1.52)	4.0 (.16)
8	1/8	12 415 0518	(11.1) 7/16"	9.5 (.37)	34.8 (1.37)	5.1 (.20)
	1/4	12 415 0528	(14.3) 9/16"	14.3 (.56)	39.6 (1.56)	5.1 (.20)
10	1/4	10 415 1028	(14.3) 9/16"	14.3 (.56)	44.1 (1.74)	7.7 (.30)
	3/8	10 415 1038	(17.5) 11/16"	14.3 (.56)	46.1 (1.81)	7.7 (.30)
12	3/8	10 415 1238	(17.5) 11/16"	14.3 (.56)	49.6 (1.95)	9.1 (.36)
	1/2	10 415 1248	(22.2) 7/8"	19.0 (.75)	54.6 (2.15)	9.1 (.36)

Pneufit Stem Adapter (Inch O.D. Stem to ISO R Thread)

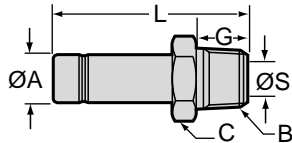

CAUTION: Straight Stem Adapters should not be used in conjunction with other union type fittings in applications where vibration is present, nor should they be used as "quick disconnects" as the mating nickel plated brass surfaces may wear over time causing eventual failure of the connection.

A Stem O.D.	B ISO R Thread	Part Number	C A/F	G	L	S
5/32	1/8	10 115 0418	10 (.39)	7.7 (.30)	30.0 (1.18)	2.1 (.08)
	1/4	10 115 0428	14 (.55)	11.1 (.44)	33.5 (1.32)	2.1 (.08)
1/4	1/8	12 115 0418	12 (.47)	7.7 (.30)	32.0 (1.26)	4.0 (.16)
	1/4	12 115 0428	14 (.55)	11.1 (.44)	35.5 (1.40)	4.0 (.16)
5/16	1/8	10 115 0818	14 (.55)	7.7 (.30)	33.0 (1.30)	5.1 (.20)
	1/4	10 115 0828	14 (.55)	11.1 (.44)	36.5 (1.44)	5.1 (.20)
3/8	1/4	12 115 0628	15 (.59)	11.1 (.44)	40.0 (1.57)	7.7 (.30)
	3/8	12 115 0638	19 (.75)	12.7 (.50)	45.0 (1.77)	7.7 (.30)
1/2	3/8	12 115 0738	19 (.75)	12.7 (.50)	48.0 (1.89)	10.0 (.39)
	1/2	12 115 0748	22 (.87)	15.9 (.63)	51.5 (2.03)	10.0 (.39)

Pneufit C Stem Adapter (Inch O.D. Stem to ISO R Thread)

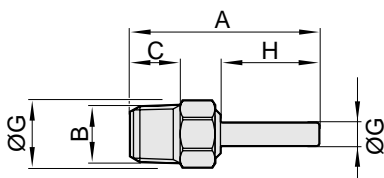

Stem	NPT Thread	Part Number	A	B	C	E	G	H
1/4"	1/8"	C21150418	1.38 (34.5)	1/8"	.34 (8.6)	.25 (6.3)	.44 (11.0)	.76 (19.0)
1/4"	1/4"	C21150428	1.48 (37.0)	1/4"	.44 (11.1)	.25 (6.3)	.40 (15.0)	.76 (19.0)
1/2"	3/8"	C21150738	2.0 (50.0)	3/8"	.51 (12.7)	.51 (12.65)	.80 (20.0)	1.10 (27.5)
1/2"	1/2"	C21150748	2.10 (52.5)	1/2"	.64 (15.9)	.51 (12.65)	.92 (23.0)	1.10 (27.5)



Inch Series Push-In Fittings

Dimensions in Inches (mm)

Pneufit Female Connector

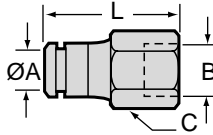

A Tube O.D.	B NPT Thread	Part Number	C A/F	L
1/8"	1/8	12 426 0118	9/16"	1.14 (29.0)
	1/4	12 426 0128	11/16"	1.38 (35.1)
5/32"	1/8	12 426 0218	9/16"	1.14 (29.0)
	1/4	12 426 0228	11/16"	1.42 (36.1)
1/4"	1/8	12 426 0418	9/16"	1.19 (30.2)
	1/4	12 426 0428	11/16"	1.46 (37.1)
5/16"	1/8	12 426 0518	9/16"	1.23 (31.2)
	1/4	12 426 0528	11/16"	1.50 (38.1)
3/8"	1/4	12 426 0628	11/16"	1.66 (42.2)
	3/8	12 426 0638	7/8"	1.70 (43.2)

Pneufit C Female Connector

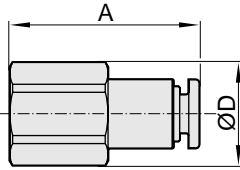

O.D. Tube	NPT Thread	Part Number	A	D
1/8"	1/8"	C24260118	1.13 (28.2)	.63 (15.8)
1/8"	1/4"	C24260128	1.41 (35.2)	.68 (17.0)
5/32"	1/8"	C24260218	1.13 (28.2)	.63 (15.8)
5/32"	1/4"	C24260228	1.41 (35.2)	.68 (17.0)
1/4"	1/8"	C24260418	1.26 (31.6)	.63 (15.8)
1/4"	1/4"	C24260428	1.52 (38.1)	.68 (17.0)
5/16"	1/8"	C24260518	1.32 (33.0)	.68 (17.0)
5/16"	1/4"	C24260528	1.62 (40.5)	.68 (17.0)
3/8"	1/4"	C24260628	1.64 (41.1)	.84 (21.0)
3/8"	3/8"	C24260638	1.68 (42.1)	.96 (24.0)

Pneufit Male Elbow

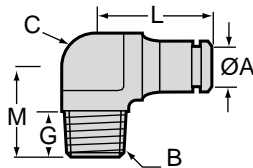

A Tube O.D.	B NPT Thread	Part Number	C A/F	G	L	M
1/8"	1/8	12 445 0118	0.28 (7.0)	0.37 (9.5)	0.67 (17.0)	0.66 (16.8)
5/32"	1/8	12 445 0218	0.28 (7.0)	0.37 (9.5)	0.67 (17.0)	0.66 (16.8)
	1/4	12 445 0228	0.43 (11.0)	0.56 (14.3)	0.72 (18.3)	0.92 (23.4)
3/16"	1/8	12 445 0318	0.28 (7.0)	0.37 (9.5)	0.72 (18.3)	0.67 (17.0)
	1/4	12 445 0328	0.43 (11.0)	0.56 (14.3)	0.79 (20.1)	0.92 (23.4)
1/4"	1/8	12 445 0418	0.31 (8.0)	0.37 (9.5)	0.77 (19.6)	0.70 (17.8)
	1/4	12 445 0428	0.43 (11.0)	0.56 (14.3)	0.79 (20.1)	0.92 (23.4)
	3/8	12 445 0438	0.63 (16.0)	0.56 (14.3)	0.84 (21.3)	1.1 (27.9)
5/16"	1/8	12 445 0518	0.43 (11.0)	0.37 (9.5)	0.84 (21.3)	0.74 (18.8)
	1/4	12 445 0528	0.43 (11.0)	0.56 (14.3)	0.84 (21.3)	0.92 (23.4)
3/8"	1/8	12 445 0618	0.52 (13.3)	0.37 (9.5)	1.05 (26.7)	0.8 (20.3)
	1/4	12 445 0628	0.52 (13.3)	0.56 (14.3)	1.05 (26.7)	0.98 (24.9)
	3/8	12 445 0638	0.63 (16.0)	0.56 (14.3)	1.05 (26.7)	1.1 (27.9)
	1/2	12 445 0648	0.94 (24.0)	0.75 (19.1)	1.13 (28.7)	1.36 (34.5)
1/2"	1/4	12 445 0728	0.63 (16.0)	0.56 (14.3)	1.25 (31.8)	1.03 (26.2)
	3/8	12 445 0738	0.63 (16.0)	0.56 (14.3)	1.25 (31.8)	1.1 (27.9)
	1/2	12 445 0748	0.94 (24.0)	0.75 (19.1)	1.25 (31.8)	1.36 (34.5)

Inch Series Push-In Fittings

Dimensions in Inches (mm)



Pneufit Swivel Male Elbow

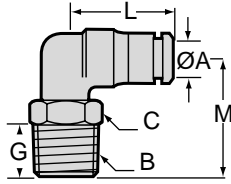

CAUTION: Swivel adapters are not suitable for use in continuously rotating or gyrating applications.

A Tube O.D.	B NPT or UNF Thrd	Part Number	C A/F	G	L	M
1/8"	10-32 UNF	12 447 0110	5/16"	0.20 (5.0)	0.63 (16.0)	0.70 (17.0)
	1/8	12 447 0118	7/16"	0.37 (9.5)	0.63 (16.0)	0.82 (20.8)
	1/4	12 447 0128	9/16"	0.37 (9.5)	0.68 (17.3)	1.07 (27.2)
5/32"	10-32 UNF	12 447 0210	5/16"	0.20 (5.0)	0.67 (17.0)	0.70 (17.0)
	1/8	12 447 0218	7/16"	0.37 (9.5)	0.67 (17.0)	0.86 (21.8)
	1/4	12 447 0228	9/16"	0.56 (14.3)	0.67 (17.0)	1.07 (27.2)
3/16"	1/8	12 447 0318	7/16"	0.37 (9.5)	0.72 (18.3)	0.88 (22.4)
	1/4	12 447 0328	9/16"	0.56 (14.3)	0.72 (18.3)	1.09 (27.7)
1/4"	10-32 UNF	12 447 0410	5/16"	0.20 (5.0)	0.77 (19.6)	0.71 (18.0)
	1/8	12 447 0418	7/16"	0.37 (9.5)	0.77 (19.6)	0.9 (22.9)
	1/4	12 447 0428	9/16"	0.56 (14.3)	0.77 (19.6)	1.11 (28.2)
	3/8	12 447 0438	3/4"	0.56 (14.3)	0.8 (20.3)	1.15 (29.2)
5/16"	1/8	12 447 0518	9/16"	0.37 (9.5)	0.84 (21.3)	0.96 (24.4)
	1/4	12 447 0528	9/16"	0.56 (14.3)	0.84 (21.3)	1.15 (29.2)
3/8"	1/8	12 447 0618	9/16"	0.37 (9.5)	1.05 (26.7)	1.05 (26.7)
	1/4	12 447 0628	11/16"	0.56 (14.3)	1.05 (26.7)	1.26 (32.0)
	3/8	12 447 0638	3/4"	0.56 (14.3)	1.05 (26.7)	1.26 (32.0)
	1/2	12 447 0648	7/8"	0.75 (19.0)	1.05 (26.7)	1.48 (37.6)
1/2"	1/4	12 447 0728	3/4"	0.56 (14.3)	1.25 (31.8)	1.37 (34.8)
	3/8	12 447 0738	3/4"	0.56 (14.3)	1.25 (31.8)	1.41 (35.8)
	1/2	12 447 0748	7/8"	0.75 (19.0)	1.25 (31.8)	1.62 (41.1)



Inch Series Push-In Fittings

Dimensions in Inches (mm)

Pneufit C Swivel Male Elbow

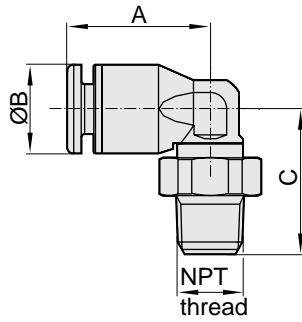

O.D. Tube	NPT Thread	Part Number	A	B	C
1/8"	1/8"	C24470118	.72 (18.0)	.43 (10.7)	.80 (20.0)
1/8"	1/4"	C24470128	.72 (18.0)	.43 (10.7)	1.04 (26.0)
5/32"	1/8"	C24470218	.72 (18.0)	.43 (10.7)	.80 (20.0)
5/32"	1/4"	C24470228	.72 (18.0)	.43 (10.7)	1.04 (26.0)
1/4"	1/8"	C24470418	.84 (21.0)	.52 (12.9)	.84 (21.0)
1/4"	1/4"	C24470428	.84 (21.0)	.52 (12.9)	1.06 (26.5)
1/4"	3/8"	C24470438	.84 (21.0)	.52 (12.9)	1.12 (28.0)
5/16"	1/8"	C24470518	.98 (24.5)	.58 (14.5)	1.29 (32.2)
5/16"	1/4"	C24470528	1.0 (25.0)	.58 (14.5)	1.08 (27.0)
3/8"	1/4"	C24470628	1.1 (27.5)	.70 (17.4)	1.66 (29.0)
3/8"	3/8"	C24470638	1.1 (27.5)	.70 (17.4)	1.24 (31.0)
3/8"	1/2"	C24470648	1.1 (27.5)	.70 (17.4)	1.46 (36.5)

Pneufit C Swivel Male Elbow

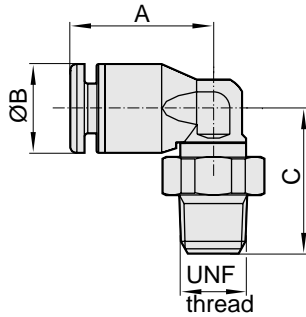

O.D. Tube	UNF Thread	Part Number	A	B	C
1/8"	10-32	C24470110	.72 (18.0)	.43 (10.7)	.70 (17.5)
5/32"	10-32	C24470210	.72 (18.0)	.43 (10.7)	.70 (17.5)
1/4"	10-32	C24470410	.84 (21.0)	.52 (12.9)	.74 (18.5)

Pneufit Extended Swivel Male Elbow

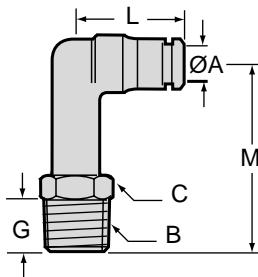

CAUTION: Swivel adapters are not suitable for use in continuously rotating or gyrating applications.

A Tube O.D.	B NPT Thread	Part Number	C A/F	G	L	M
5/32"	1/8"	12 454 0218	7/16"	0.37 (9.5)	0.67 (16.9)	1.39 (35.3)
5/32"	1/4"	12 454 0228	7/16"	0.37 (9.5)	0.77 (19.6)	1.49 (37.9)
1/4"	1/8"	12 454 0418	9/16"	0.56 (14.3)	0.67 (16.9)	1.71 (43.5)
1/4"	1/4"	12 454 0428	9/16"	0.56 (14.3)	0.77 (19.6)	1.75 (44.5)
3/8"	1/4"	12 454 0628	11/16"	0.56 (14.3)	1.05 (26.7)	2.10 (53.4)
3/8"	3/8"	12 454 0638	3/4"	0.56 (14.3)	1.05 (26.7)	2.10 (53.4)

Pneufit C Extended Swivel Male Elbow

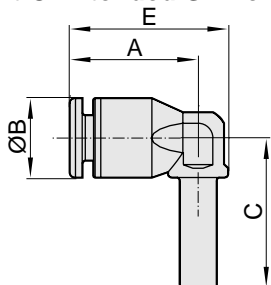

O.D. Tube	Stem	Part Number	A	B	C	E
1/4"	1/4"	C20430400	.63 (21.0)	.52 (12.9)	.98 (24.5)	1.04 (26.0)



NOTE: ISO G elbows to be added 3rd quarter of 2001

Description	Part Number
Straight Adaptor 1/4 O.D. Tube x M5	122250405
Straight Adaptor 1/4 O.D. Tube x 1/4 ISO G	122250428
Straight Adaptor 3/8 O.D. Tube x 1/4 ISO G	122250628
Straight Adaptor 3/8 O.D. Tube x 3/8 ISO G	122250638
Straight Adaptor 1/2 O.D. Tube x 3/8 ISO G	122250738
Straight Adaptor 1/2 O.D. Tube x 1/2 ISO G	122250748
Swivel Elbow 1/4 O.D. Tube x M5	122470405
Swivel Elbow 1/4 O.D. Tube x 1/8 ISO G	122470418
Swivel Elbow 1/4 O.D. Tube x 1/4 ISO G	122470428
Swivel Elbow 3/8 O.D. Tube x 1/4 ISO G	122470628
Swivel Elbow 3/8 O.D. Tube x 3/8 ISO G	122470638
Swivel Elbow 1/2 O.D. Tube x 3/8 ISO G	122470738
Swivel Elbow 1/2 O.D. Tube x 1/2 ISO G	122470748

Swivel Female Elbow

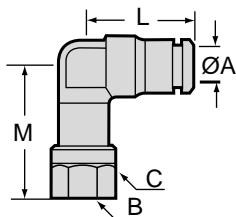

CAUTION: Swivel adapters are not suitable for use in continuously rotating or gyrating applications.

A Tube O.D.	B NPT Thread	Part Number	C A/F	L	M
1/8"	1/8	12 448 0118	9/16"	0.63 (15.9)	1.19 (30.1)
5/32"	1/8	12 448 0218	9/16"	0.67 (16.9)	1.19 (30.1)
5/32"	1/4	12 448 0228	11/16"	0.67 (16.9)	1.40 (35.6)
1/4"	1/8	12 448 0418	9/16"	0.77 (19.6)	1.22 (31.1)
1/4"	1/4	12 448 0428	11/16"	0.77 (19.6)	1.44 (36.6)
5/16"	1/4	12 448 0528	11/16"	0.84 (21.3)	1.48 (37.6)
3/8"	1/4	12 448 0628	11/16"	1.05 (26.7)	1.58 (40.1)
1/2"	3/8	12 448 0738	7/8"	1.25 (31.7)	1.82 (46.2)



Inch Series Push-In Fittings

All Dimensions in Inches (mm)

Pneufit Swivel Male Branch Tee

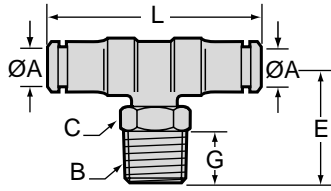

CAUTION: Swivel adapters are not suitable for use in continuously rotating or gyrating applications.

A Tube O.D.	B NPT or UNF Thrd	Part Number	C A/F	G	L	E
1/8"	10-32 UNF	12 467 0110	5/16"	0.20 (5.0)	1.25 (32.0)	0.73 (18.5)
	1/8	12 467 0118	7/16"	0.37 (9.5)	1.26 (32.0)	0.81 (20.7)
	1/4	12 467 0128	9/16"	0.56 (14.3)	1.34 (34.0)	1.07 (27.1)
5/32"	10-32 UNF	12 467 0210	5/16"	0.20 (5.0)	1.34 (34.0)	0.77 (19.5)
	1/8	12 467 0218	7/16"	0.37 (9.5)	1.33 (33.8)	0.86 (21.8)
	1/4	12 467 0228	9/16"	0.56 (14.3)	1.33 (33.8)	1.07 (27.1)
3/16"	1/8	12 467 0318	7/16"	0.37 (9.5)	1.45 (36.8)	0.88 (22.3)
	1/4	12 467 0328	9/16"	0.56 (14.3)	1.45 (36.8)	1.09 (27.6)
1/4"	1/8	12 467 0418	7/16"	0.37 (9.5)	1.54 (39.2)	0.90 (22.8)
	1/4	12 467 0428	9/16"	0.56 (14.3)	1.54 (39.2)	1.12 (28.1)
	3/8	12 467 0438	3/4"	0.56 (14.3)	1.57 (40.0)	1.20 (30.5)
5/16"	1/8	12 467 0518	9/16"	0.37 (9.5)	1.68 (42.6)	0.96 (24.3)
	1/4	12 467 0528	9/16"	0.56 (14.3)	1.68 (42.6)	1.15 (29.1)
3/8"	1/8	12 467 0618	9/16"	0.37 (9.5)	2.10 (53.4)	0.66 (16.7)
	1/4	12 467 0628	11/16"	0.56 (14.3)	2.10 (53.4)	1.26 (32.0)
	3/8	12 467 0638	3/4"	0.56 (14.3)	2.10 (53.4)	1.26 (32.0)
	1/2	12 467 0648	7/8"	0.75 (19.0)	2.10 (53.4)	1.48 (37.5)
1/2"	1/4	12 467 0728	3/4"	0.56 (14.3)	2.50 (63.4)	1.37 (34.8)
	3/8	12 467 0738	3/4"	0.56 (14.3)	2.50 (63.4)	1.41 (35.7)
	1/2	12 467 0748	7/8"	0.75 (19.0)	2.50 (63.4)	1.62 (41.2)

Pneufit C Swivel Male Branch Tee

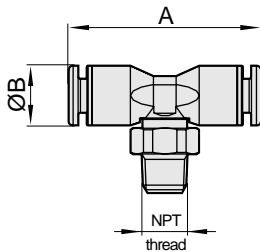

O.D. Tube	NPT Thread	Part Number	A	B
1/8"	1/8"	C24670118	1.44 (36.0)	.43 (10.7)
5/32"	1/8"	C24670218	1.44 (36.0)	.43 (10.7)
5/32"	1/4"	C24670228	1.44 (36.0)	.43 (10.7)
1/4"	1/8"	C24670418	1.68 (42.0)	.52 (12.9)
1/4"	1/4"	C24670428	1.68 (42.0)	.52 (12.9)
1/4"	3/8"	C24670438	1.68 (42.0)	.52 (12.9)
5/16"	1/4"	C24670528	2.0 (50.0)	.58 (14.5)
3/8"	1/8"	C24670618	2.2 (55.0)	.70 (17.4)
3/8"	1/4"	C24670628	2.2 (55.0)	.70 (17.4)
3/8"	3/8"	C24670638	2.2 (55.0)	.70 (17.4)

Inch Series Push-In Fittings

All Dimensions in Inches (mm)



Pneufit Swivel Male Run Tee

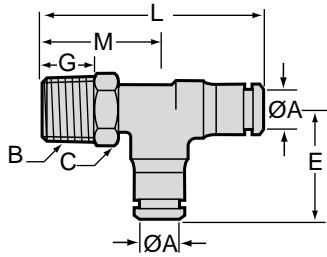

CAUTION: Swivel adapters are not suitable for use in continuously rotating or gyrating applications.

A Tube O.D.	B NPT or UNF Thrd	Part Number	C				
			A/F	G	L	M	E
1/8"	10-32 UNF	12 468 0110	5/16"	0.63 (16.0)	1.36 (34.5)	0.63 (16.0)	1.36 (34.5)
	1/8	12 468 0118	7/16"	0.63 (9.5)	1.36 (34.5)	0.73 (18.5)	0.63 (16.0)
	1/4	12 468 0128	9/16"	0.67 (14.3)	1.44 (36.5)	0.77 (19.5)	0.67 (17.0)
5/32"	10-32 UNF	12 468 0210	5/16"	0.67 (17.0)	1.44 (36.5)	0.67 (17.0)	1.44 (36.6)
	1/8	12 468 0218	7/16"	0.67 (9.5)	1.52 (38.7)	0.86 (21.8)	0.67 (16.9)
	1/4	12 468 0228	9/16"	0.67 (16.9)	1.73 (44.0)	1.07 (27.1)	0.67 (16.9)
3/16"	1/8	12 468 0318	7/16"	0.72 (9.5)	1.60 (40.7)	0.88 (22.3)	0.72 (18.4)
	1/4	12 468 0328	9/16"	0.72 (14.3)	1.81 (46.0)	1.09 (27.6)	0.72 (18.4)
1/4"	1/8	12 468 0418	7/16"	0.77 (9.5)	1.67 (42.4)	0.90 (22.8)	0.77 (19.6)
	1/4	12 468 0428	9/16"	0.77 (14.3)	1.88 (47.7)	1.11 (28.1)	0.77 (19.6)
	3/8	12 468 0438	3/4"	0.79 (14.3)	1.59 (40.5)	0.81 (20.5)	0.79 (20.0)
5/16"	1/8	12 468 0518	9/16"	0.84 (9.5)	1.80 (45.6)	0.96 (24.3)	0.84 (21.3)
	1/4	12 468 0528	9/16"	0.84 (14.3)	1.98 (50.4)	1.15 (29.1)	0.84 (50.3)
3/8"	1/8	12 468 0618	9/16"	1.05 (9.5)	2.00 (50.7)	0.94 (24.0)	1.05 (26.7)
	1/4	12 468 0628	11/16"	1.05 (14.3)	2.31 (58.7)	1.26 (32.0)	1.05 (26.7)
	3/8	12 468 0638	3/4"	1.05 (14.3)	2.31 (58.7)	1.26 (32.0)	1.05 (26.7)
	1/2	12 468 0648	7/8"	1.05 (19.0)	2.53 (64.2)	1.48 (37.5)	1.05 (26.7)
1/2"	1/4	12 468 0728	3/4"	1.25 (14.3)	2.62 (66.5)	1.37 (34.8)	1.25 (31.7)
	3/8	12 468 0738	3/4"	1.25 (14.3)	2.65 (67.4)	1.41 (35.7)	1.25 (31.7)
	1/2	12 468 0748	7/8"	1.25 (19.0)	2.87 (72.9)	1.62 (41.2)	1.25 (31.7)

Pneufit C Swivel Male Run Tee

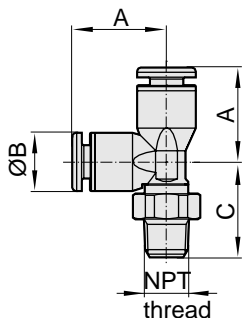

O.D. Tube	NPT Thread	Part Number	A	B	C
1/8"	1/8"	C24680118	.72 (18.0)	.43 (10.7)	.80 (20.0)
5/32"	1/8"	C24680218	.72 (18.0)	.43 (10.7)	.80 (20.0)
5/32"	1/4"	C24680228	.72 (18.0)	.43 (10.7)	1.04 (26.0)
1/4"	1/8"	C24680418	.84 (21.0)	.52 (12.9)	.84 (21.0)
1/4"	1/4"	C24680428	.84 (21.0)	.52 (12.9)	1.06 (26.5)
5/16"	1/4"	C24680528	1.00 (25.0)	.58 (14.5)	1.08 (27.0)
3/8"	1/4"	C24680628	1.10 (27.5)	.70 (17.4)	1.16 (29.0)
3/8"	3/8"	C24680638	1.10 (27.5)	.70 (17.4)	1.24 (31.0)



Inch Series Push-In Fittings

All Dimensions in Inches (mm)

Pneufit Parallel Male Y Swivel

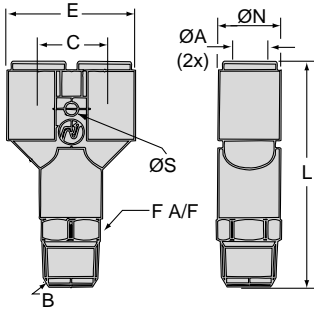

A Tube O.D.	B NPT Thread	Part Number	C	E	F A/F	L	ØN	ØS**
5/32"	1/8	12 488 0218	0.43 (11.0)	0.89 (22.5)	7/16"	1.72 (43.7)	0.45 (11.5)	0.13 (3.2)
5/32"	1/4	12 488 0228	0.63 (16.0)	0.89 (22.5)	9/16"	2.01 (51.1)	0.45 (11.5)	0.13 (3.2)
1/4"	1/8	12 488 0418	0.55 (14.0)	1.10 (28.0)	7/16"	1.90 (48.2)	0.55 (14.0)	0.13 (3.2)
1/4"	1/4	12 488 0428	0.55 (14.0)	1.10 (28.0)	9/16"	2.19 (55.5)	0.55 (14.0)	0.13 (3.2)
3/8"	1/4	12 488 0628	0.87 (22.0)	1.67 (42.5)	3/4"	2.70 (68.5)	0.79 (20.0)	0.17 (4.2)
3/8"	3/8	12 488 0638	0.87 (22.0)	1.67 (42.5)	3/4"	2.70 (68.5)	0.79 (20.0)	0.17 (4.2)
3/8"	1/2	12 488 0648	0.87 (22.0)	1.67 (42.5)	7/8"	2.88 (73.2)	0.79 (20.0)	0.17 (4.2)

Body Material: Thermoplastic

** Mounting hole

Pneufit C Parallel Male Y Swivel

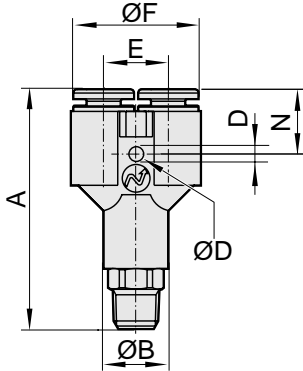

O.D. Tube	NPT Thread	Part Number	A	B	D	E	F	N
5/32"	1/8"	C24880218	1.96 (49.0)	.44 (11.0)	.128 (3.2)	.44 (11.0)	.88 (22.0)	.52 (13.0)
5/32"	1/4"	C24880228	2.2 (55.0)	.44 (11.0)	.128 (3.2)	.44 (11.0)	.88 (22.0)	.52 (13.0)
1/4"	1/8"	C24880418	2.1 (52.5)	.56 (14.0)	.128 (3.2)	.56 (14.0)	1.12 (28.0)	.57 (14.25)
1/4"	1/4"	C24880428	2.32 (58.0)	.56 (14.0)	.128 (3.2)	.56 (14.0)	1.12 (28.0)	.57 (14.25)
3/8"	1/4"	C24880628	2.9 (72.5)	.80 (20.0)	.168 (4.2)	.82 (20.6)	1.68 (42.0)	.60 (14.90)
3/8"	3/8"	C24880638	2.9 (72.5)	.80 (20.0)	.168 (4.2)	.82 (20.6)	1.68 (42.0)	.60 (14.90)
3/8"	1/2"	C24880648	3.08 (77.0)	.80 (20.0)	.168 (4.2)	.82 (20.6)	1.68 (42.0)	.60 (14.90)

Pneufit Banjo Elbow

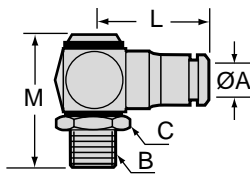

Note: Regulating Banjos are shown in Section 3 Function Fittings and Flow Controls

A Tube O.D.	B NPT or UNF Thread	Part Number	C A/F	M	L
1/8"	1/8	12 R51 0118	9/16"	1.22 (31.0)	0.80 (20.4)
5/32"	10-32 UNF	12 R51 0210	5/16"	0.87 (22.0)	0.74 (18.7)
	1/8	12 R51 0218	9/16"	1.22 (31.0)	0.81 (20.6)
1/4"	1/8	12 R51 0418	9/16"	1.22 (31.0)	0.93 (23.7)
	1/4	12 R51 0428	11/16"	1.50 (38.0)	0.95 (24.2)
	3/8	12 R51 0438	7/8"	1.74 (44.3)	1.03 (26.2)
3/8"	1/4	12 R51 0628	11/16"	1.50 (38.0)	1.19 (30.2)
	3/8	12 R51 0638	7/8"	1.74 (44.3)	1.23 (31.2)

Inch Series Push-In Fittings

All Dimensions in Inches (mm)



Pneufit Banjo Tee

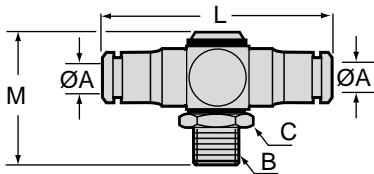

A Tube O.D.	B NPT or UNF Thread	Part Number	C A/F	M	L
5/32"	10-32 UNF	12 R71 0210	5/16"	0.87 (22.0)	1.48 (37.6)
1/4"	1/8	12 R71 0418	9/16"	1.22 (31.0)	1.86 (47.0)
	1/4	12 R71 0428	11/16"	1.50 (38.0)	1.90 (48.3)
3/8"	1/4	12 R71 0628	11/16"	1.50 (38.0)	2.38 (60.4)
	3/8	12 R71 0638	7/8"	1.74 (44.3)	2.46 (62.4)

Pneufit Plug*

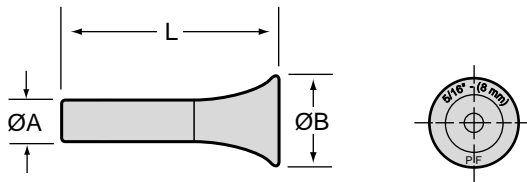

*Material: Thermoplastic

A Stem O.D.	Part Number	ØB	L
5/32"	11 004 0400	0.38 (9.6)	1.04 (26.5)
3/16"	13 004 0300	0.42 (11.6)	1.12 (28.5)
1/4"	94 050 904	0.46 (10.6)	1.10 (28.0)
5/16"	11 004 0800	0.50 (12.7)	1.16 (29.5)
3/8"	94 050 906	0.61 (15.6)	1.34 (34.0)
1/2"	94 050 907	0.65 (16.4)	1.48 (37.5)

Pneufit Plug*

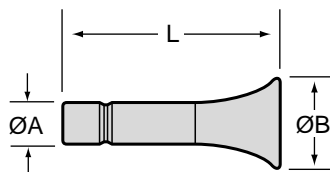

* Material: Nickel plated Brass

A Stem O.D.	Part Number	ØB	L
1/8"	12 004 0100	0.34 (8.6)	1.02 (25.9)
5/32"	12 004 0200	0.38 (9.6)	1.04 (26.4)
3/16"	12 004 0300	0.42 (10.6)	1.1 (27.9)
1/4"	12 004 0400	0.46 (11.6)	1.12 (28.4)
5/16"	12 004 0500	0.50 (12.7)	1.16 (29.5)
3/8"	12 004 0600	0.61 (15.6)	1.34 (34.0)
1/2"	12 004 0700	0.66 (16.7)	1.48 (37.6)

Pneufit Barb Adapter

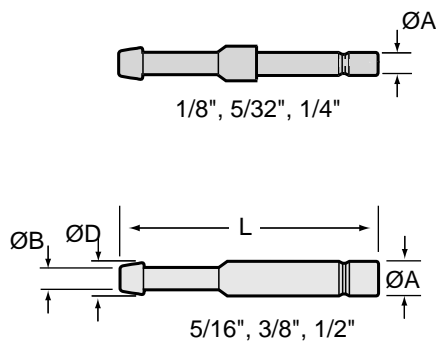

1/8", 5/32", 1/4"

5/16", 3/8", 1/2"

A Stem O.D.	B Hose Bore	Part Number	D	L (ref)
1/8"	1/8"	12 019 0101	0.17 (4.2)	1.34 (34.0)
5/32"	1/8"	12 019 0201	0.17 (4.2)	1.35 (34.3)
1/4"	3/16"	12 019 0403	0.24 (6.2)	1.43 (36.3)
5/16"	1/4"	12 019 0504	0.31 (7.9)	1.47 (37.3)
3/8"	5/16"	12 019 0605	0.37 (9.5)	1.70 (43.2)
1/2"	3/8"	12 019 0706	0.47 (11.9)	1.84 (46.7)



Inch Series Push-In Fittings

All Dimensions in Inches (mm)

Pneufit Manifold*

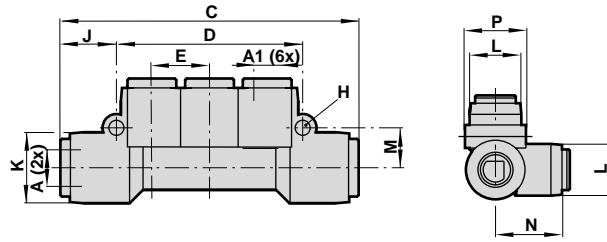

Product Number	A Tube O.D.	A1 Tube O.D.	C	D	E	H	J	K	L	M	N	P
12 OD6 0402	1/4	5/32	2.74 (70)	1.65 (42)	0.51 (13)	0.13 (3)	0.50 (13)	0.63 (16)	0.55 (14)	0.35 (9)	0.79 (20)	0.65 (16)
12 OD6 0502	5/16	5/32	2.66 (68)	1.65 (42)	0.51 (13)	0.13 (3)	0.50 (13)	0.63 (16)	0.55 (14)	0.35 (9)	0.80 (20)	0.65 (16)
12 OD6 0604	3/8	1/4	3.25 (83)	1.89 (48)	0.59 (15)	0.13 (3)	0.68 (17)	0.79 (20)	0.63 (16)	0.41 (11)	0.90 (23)	0.80 (20)
12 OD6 0605	3/8	5/16	3.25 (83)	1.89 (48)	0.59 (15)	0.13 (3)	0.68 (17)	0.79 (20)	0.63 (16)	0.41 (11)	0.90 (23)	0.80 (20)

* Body material thermoplastic

Pneufit Manifold*

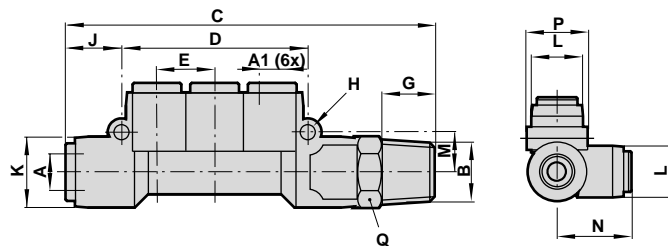

Product Number	A Tube O.D.	A1 Tube O.D.	B NPT thread	C	D	E	G	H	J	K	L	M	N	P	Q A/F
12 4D6 0228	5/16	5/32	1/4	3.37 (42)	1.65 (13)	0.51 (11)	0.44 (3)	0.13 (13)	0.50 (16)	0.63 (14)	0.55 (9)	0.35 (20)	0.80 (16)	0.65 (17)	11/16
12 4D6 0238	5/16	5/32	3/8	3.39 (42)	1.65 (13)	0.51 (13)	0.50 (3)	0.13 (13)	0.50 (16)	0.63 (14)	0.55 (9)	0.35 (20)	0.80 (16)	0.65 (19)	3/4
12 4D6 0428	5/16	1/4	1/4	3.37 (42)	1.65 (13)	0.51 (11)	0.44 (3)	0.13 (13)	0.50 (16)	0.63 (14)	0.55 (9)	0.35 (23)	0.89 (16)	0.65 (17)	11/16
12 4D6 0438	5/16	1/4	3/8	3.41 (42)	1.65 (13)	0.51 (12)	0.50 (3)	0.13 (13)	0.50 (16)	0.63 (14)	0.55 (9)	0.35 (23)	0.89 (16)	0.65 (19)	3/4
12 4D6 0448	3/8	1/4	1/2	4.06 (48)	1.89 (15)	0.59 (12)	0.50 (3)	0.13 (17)	0.68 (20)	0.79 (16)	0.63 (11)	0.41 (23)	0.89 (20)	0.80 (22)	7/8
12 4D6 0548	3/8	5/16	1/2	4.21 (48)	1.89 (15)	0.59 (16)	0.63 (3)	0.13 (17)	0.68 (20)	0.79 (16)	0.63 (11)	0.41 (23)	0.89 (20)	0.80 (22)	7/8

* Body material thermoplastic

Pneufit® Metric Series Push-In Tube Fittings

4 mm to 14 mm Tube Sizes
M5 to 1/2" ISO G and ISO R
Thread Options

Metric Series Product Numbering System	FIT-2-2
Metric Series Shapes and Codes	FIT-2-3
Metric Series Specifications	FIT-2-4
Metric Series Features and Benefits	FIT-2-5
Metric Series Thread Forms	FIT-2-6
Metric Series Mating Threads	FIT-2-7
Metric Series Part Numbers and Dimensional Information ..	FIT-2-9

Pneufit 12 Series

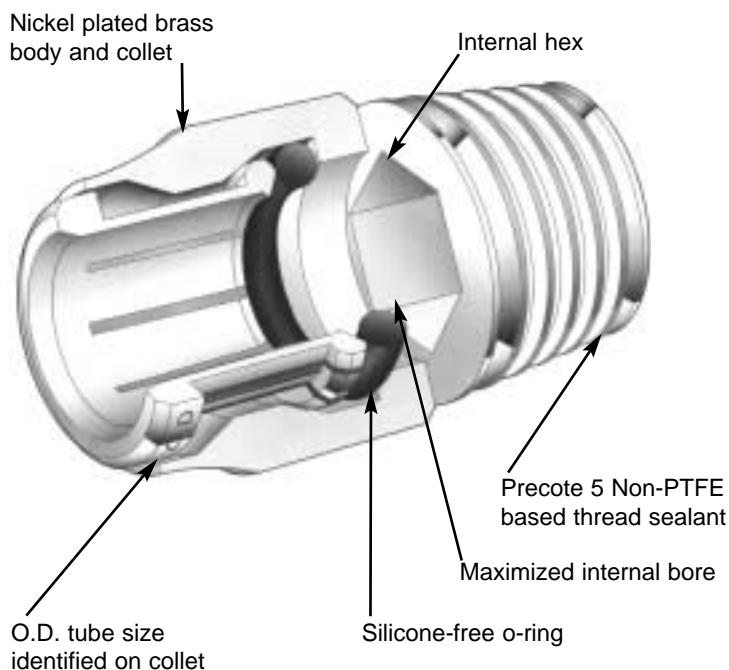

Pneufit C2 Series

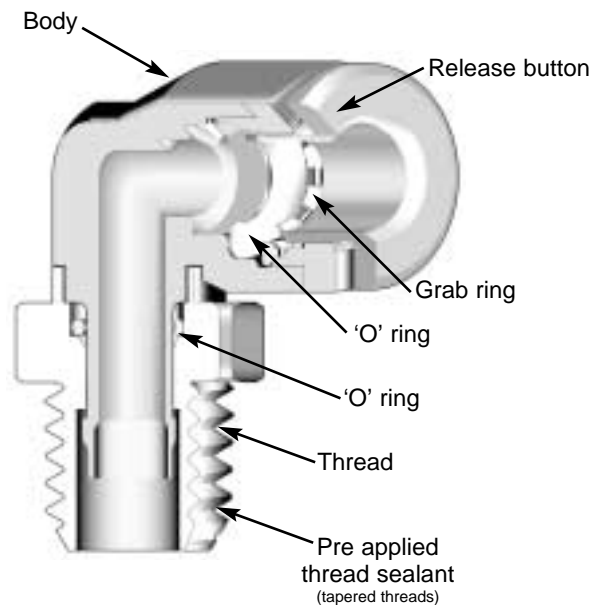



Product Numbering System

Position → **1 0 3 4 5 6 7 8 9 (V)**

Fitting Series Number

- 10 Brass push-in fittings (metric) nickel plate + washers, sealant, assembled
- 11 Plastic push-in fittings (metric)
- 12 Brass push-in fittings (inch) nickel plate + washers, sealant assembled
- 13 Plastic push-in fittings (inch)
- 15 ISO R Pipe Fittings Brass Nickel Plate
- 16 ISO G Pipe Fittings Brass Nickel Plate + Washers Assembled
- 20 ISO G Banjo Bolts
- 21 Metric WeldFit
- 33 Inch WeldFit
- C0 Pneufit Metric
- C2 Pneufit Inch

Suffix Position (Optional)

- BP Bulk packaging
- GR ISO R thread
- V Viton seals 10/12 Series only
- XA Without thread sealant

Thread Size

- | | |
|---------------|----------|
| 18 | 1/8 |
| 28 | 1/4 |
| 38 | 3/8 |
| 48 | 1/2 |
| UNF | |
| 10 | 10-32 |
| Metric | |
| 05 | M5 x 0.8 |

Thread/Banjo Bolt

- 0 No port thread
- 1 ISO R
- 2 ISO G + M5
- 4 NPTF + 10-32 UNF
- A Single bolt
- B Double bolt
- C Triple bolt
- D Single bolt M5 top port
- E Single bolt G 1/8 top port
- F Single bolt G 1/4 top port
- G Single bolt G 3/8 top port
- J Single bolt with test point
- K ISO G Single bolt - regulating out
- T ISO R Single bolt - regulating out
- V NPTF Single bolt - regulating out
- W NPTF Single bolt - regulating out
- Z NPTF Single bolt - bi-directional

Tube Size

Inch O.D.		Metric O.D.	
01	1/8"	04	4 mm
02	5/32"	05	5 mm
03	3/16"	06	6 mm
04	1/4"	08	8 mm
05	5/16"	10	10 mm
06	3/8"	12	12 mm
07	1/2"	14	14 mm

Fitting Shape

See facing page for shapes and codes.



Positions 4 and 5 denote fitting shape

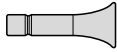

04 Plug – O.D. Tube Stem
p. FIT-2-36



10 Stem mounted pressure indicator –
p. FIT-2-36.



15 Stem adapter – O.D. tube stem to male thread p. Fit-2-(21-23).



19 Barb adapter – O.D. tube stem to hose bore p. FIT-2-36.



20 Union – O.D. tube to O.D. tube p. FIT-2-(11-12).



22 Double Male Union – O.D. tube stem to O.D. tube FIT-2-11.



23 Tube End Reducer – O.D. tube stem to O.D. tube p. FIT-2-13.



24 Self Sealing (Checked) Connector – O.D. tube to male thread p. FIT-2-20.



25 Male Connector – O.D. tube to male thread p. FIT-2-(18-20).



26 Female Connector – O.D. tube to female thread p. FIT-2-24.

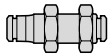

29 Bulkhead Union – O.D. tube to O.D. tube p. FIT-2-14.



37 Conversion Union (metric O.D. tube to inch O.D. tube) p. FIT-2-12



40 Union Elbow – O.D. tube to O.D. tube p. FIT-2-14.



43 Stem Elbow – O.D. tube stem to O.D. tube p. FIT-2-15.



45 Male Elbow – O.D. tube to male thread p. FIT-2-25.



47 Swivel Male Elbow –O.D. tube to male thread p. FIT-2-(26-27).



49 Swivel Bulkhead Union Elbow w/lock-nut – O.D. tube to O.D. tube p. FIT-2-15.



51 Banjo Elbow – O.D. tube to male thread p. FIT-2-33.



57 Swivel 45° Male Elbow – O.D. tube to male thread p. FIT-2-33.

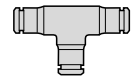

60 Union Tee – O.D. tube p. FIT-2-16.

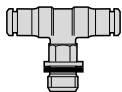

67 Swivel Male Branch Tee – O.D. tube (2) to male thread p. FIT-2-(28-29).

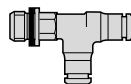

68 Swivel Male Run Tee – O.D. tube (2) to male thread p. FIT-2-(30-32).

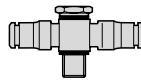

71 Tee banjo assembly – p. FIT-2-26.
Banjo bolt p. FIT-2-(27-28).
Banjo body p. FIT-2-(28-29)

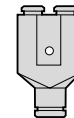

82 Parallel Union Y Connector – O.D. Tube p. FIT-2-17.

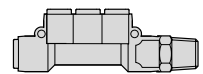

0D6 and 1D6 Manifold – multiple O.D. tube, and multiple O.D. tube to male thread p. FIT-2-38



20 Hex Nipple – Male thread p. FIT-2-37

- Reduced assembly and maintenance time.
- Expanded pressure rating.
- Pre-applied thread sealant.
- Silicone free o-rings.
- Nickel plated brass bodies and collets.
- Maximum flows in a reduced size.

Specifications

Fluid: Compressed air, nitrogen, inert and non-combustible gases compatible with materials of construction. *For other types of fluids or compressed gases, please consult factory.*

Working Pressure: 750 mm Hg to 18 bar
(29.5" Hg vacuum to 260 psig)

Note: Flow Controls working pressures:
.3 to 10 bar (5 to 150 psig)

Working Temperature: -20° to 80°C (0° to 175°F)
See Viton® Option for extended temperature range : -20° to 180°C (0° to 350°F)

Materials of Construction

Body, swivel fitting and collet: Nickel plated brass

O-ring: Silicone free Nitrile

Sealing washer (parallel male threads): Thermoplastic

Tubing: Nylon 11 or Nylon 12, Polyurethane (95 durometer or above) and LDPE (Low Density Polyethylene).

Note: Lower durometer polyurethane may be used, however, an internal tube support is required to prevent internal collapse of the tube wall.

Thread Sealant: Precote 5 thread sealant is factory applied to the circumference of tapered male threads (ISO R).



Recommended tube tolerances

Tube O.D.	O.D. Tube Tolerances	
	Nylon	Polyurethane
4 mm to 5 mm (5/32" to 3/16")	+0.05 mm (+0.002") -0.07 mm (-0.003")	±0.10 mm (±0.004")
6 mm to 14 mm (1/4" to 1/2")	+0.05 mm (+0.002") -0.10 mm (-0.004")	

LDPE –Tolerances specified in DIN 73378 or BS54-09/1:1976

Recommended tightening torques

Thread Size	Tightening Torque Nm (ft lbs)	
	ISO R	ISO G*
M5	—	1 - 1.4 (.75 - 1.05)
1/8	6.9 - 8.8 (5.0 - 6.5)	7 - 9 (5.3 - 6.8)
1/4	11.8 - 13.7 (8.7 - 10.0)	9 - 12 (6.8 - 9.0)
3/8	21.6 - 23.5 (15.9 - 17.3)	34 - 38 (25.5 - 28.5)
1/2	27.4 - 29.4 (20.2 - 21.7)	41 - 47 (30.8 - 35.3)

* Lower torques can be used to achieve a seal but these figures are recommended to provide some vibration resistance.

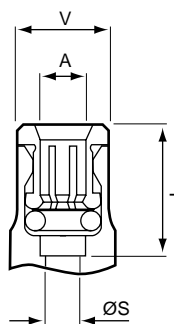

Typical Dimensions mm (in.)

A O.D. Tube	S	T Tubing Stop	V
4 (5/32")	2.8 (.11)	14.0 (.55)	7.5 (.30)
5	3.4 (.13)	15.0 (.59)	10.0 (.39)
6	4.4 (.17)	15.5 (.61)	11.0 (.43)
8 (5/16")	6.0 (.24)	16.5 (.65)	13.0 (.51)
10	7.6 (.30)	21.0 (.83)	14.5 (.57)
12	9.6 (.38)	24.5 (.96)	18.0 (.71)
14	11.5 (.45)	24.5 (.96)	20.0 (.79)

Options

Viton® fluoroelastomers can be supplied for chemical compatibility or expanded temperature range requirements. To order fittings with Viton elastomers, add a "V" suffix to the part number.

Example: To order part 10 060 0600 with Viton, add "V" to the end of the number, i.e. 10 060 0600V.

The temperature range for fittings equipped with Viton elastomers is -20° to 180°C (0° to 350°F)

NOTE: Fittings equipped with ISO G (male) and M5 threads use a molded thermoplastic washer to effect a face seal. The maximum service temperature of this seal is 80°C (175°F). In the case of thread sizes G1/8 and greater, substitute the ISO R male fitting with Viton. In the case of the M5 male thread, a Viton bonded sealing washer is available for extended temperature service. Order part number 48 021 605V and use it in place of the thermoplastic seals provided with fittings incorporating M5 male threads. These washers are also suitable for use with 10-32 UNF (male) Pneufit Adapter fittings, and are supplied in packages of 10.

Pneufit C Composite Fittings Metric



Ø 3 to 10 mm O/D tube



- Releasable grab ring technology combining plastic and brass components for a compact and superior fitting design
- Colour coding option available with tamper-resistance feature. See C Clips - reference (tubing section)
- Moulded mounting brackets on tube connector designs
- Light weight design
- Red release sleeve indicates metric tube size
- Silicone free 'O' ring seals
- Grips soft PU tube through to copper and stainless steel
- Reusable 'O' ring seals on parallel threads
- Non-PTFE based thread sealant on tapered threads
- Easy tube insertion for rapid and quick assembly of pneumatic circuits
- Internal hexagon on straight adaptors allows assembly in confined spaces
- Reliable and corrosion resistant

Tube sizes

3, 4, 6, 8, 10mm O/D

Warning: The Pneufit C design is not to be used with vehicle air braking or ancillary systems. For push-in fittings suitable for these applications, please refer to the Fleetfit range or contact Technical Sales for assistance

Tube types

Nylon 11 or 12, polyurethane* and other plasticised or unplasticised tubing which conforms to the tolerances specified in DIN 73378, NFE 49-101, ISO / WD 16026, ISO / WD 16627
Copper and stainless steel

* Suitable for 85D

Torque figures

Thread sealant is applied to the full circumference of the thread. The recommended tightening torque figures for designs with thread sealant are found in the torque table below

Thread (BSPT)	Tightening torque (Nm)
1/8"	6.7 – 8.8
1/4"	11.8 – 13.7
3/8"	21.6 – 25.3
1/2"	27.4 – 29.4

Technical data

Medium:

Compressed air

Operating pressure:

Vacuum - 18 bar unless otherwise stated (dependant on tubing specification)

Ambient temperature:

-20° to +80° C

Materials

Bodies: plastic - PBT, except straight adaptors and straight stem adaptors

Straight adaptors: nickel plated brass

Straight stem adaptors: plastic - acetal

Threads: nickel plated brass

Grab ring: stainless steel - BS 1440 Pt 2, grade 301.S21

'O' rings: silicone free nitrile

Thread sealant: non PTFE

Typical dimensions (mm)

A	S†	T*	V
O/D tube		Tube stop	
3 mm	2.3	15.3	10.7
4 mm	2.8	15.3	10.7
6 mm	4.4	17.1	12.9
8 mm	6.0	19.2	14.5
10 mm	7.7	20.25	17.6

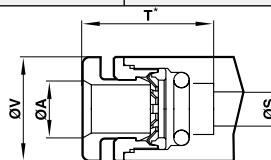

* Dimensions here and in the individual tables refer to the release button in the 'OUT' position

Dimensions here (minimum bore diameter) are common per tube size for all connectors, elbow and tees unless otherwise stated



Pneufit C Composite Fittings Metric

Straight Adaptors and Connectors

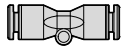

C0020 Straight connector
- tube to tube
p. FIT-2-12

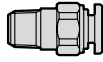

C0125 Straight adaptor
- tube to BSPT
male thread
p. FIT-2-19



C0225 Straight adaptor
- tube to BSPP
male thread
p. FIT-2-18

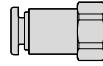

C0226 Female straight
- adaptor tube to
female BSPP thread
p. FIT-2-24

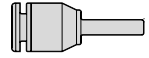

C0023 Straight stem
adaptor
- tube to stem
p. FIT-2-13



C0115 Straight stem
adaptor - stem to
BSPT male thread
p. FIT-2-22

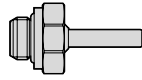

C0215 Straight stem
adaptor - stem to
BSPP male thread
p. FIT-2-21



C0040 90° Elbow
connector
- tube to tube
p. FIT-2-14

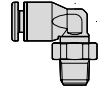

C0147 90° Swivel elbow
adaptor - tube to
BSPT male thread
p. FIT-2-27

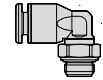

C0247 90° Swivel elbow
adaptor - tube to
BSPP male thread
p. FIT-2-26

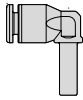

C0043 90° Stem elbow
- tube to stem
p. FIT-2-15

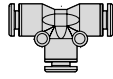

C0060 Tee connector -
tube to tube
p. FIT-2-16

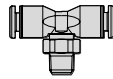

C0167 Swivel tee adaptor
- tube to BSPT
male thread
p. FIT-2-29

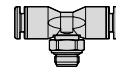

C0267 Swivel tee adaptor
- tube to BSPP
male thread
p. FIT-2-28

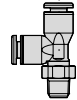

C0168 Swivel side tee
adaptor - tube to
BSPT male thread
p. FIT-2-32

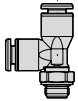

C0268 Swivel side tee
adaptor - tube to
BSPP male thread
p. FIT-2-30

Pneufit C construction:
90° swivel elbow adaptor

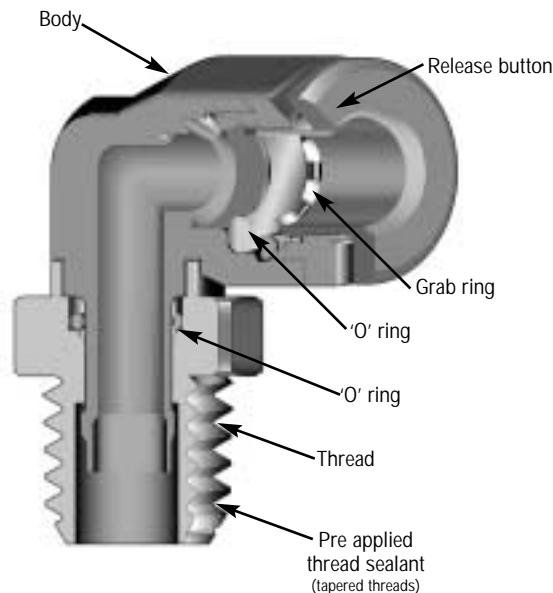



NORGREN metric push-in fittings provide a simple means of connecting compressed air products to system piping. They are designed for use with flexible thermoplastic tubing and are available in a wide range of configurations to fit nearly every conceivable application.

Reduced Assembly and Maintenance Time

Norgren Push-In Fittings reduce assembly time by 70 to 80% by eliminating the time consuming insertion of ferrules and wrenching of compression nuts. Also, no tools are required for the insertion or removal of tubing from fittings, simplifying plumbing modifications and repairs.

Reduced Installation Distances

All straight Norgren Push-In Fittings feature internal hexes. Since the wrench is applied internally to the fittings rather than externally, the fittings can be located virtually shoulder to shoulder.

Expanded Pressure Rating

With a pressure operating range of 750 mm Hg vacuum to 18 bar (29.5" Hg vacuum to 260 psig), one fitting covers over 98% of applications, extending the usable range of push-in fittings and reducing both inventory and stocking requirements.

Pre-applied thread sealant

Precote 5, a non-PTFE based thread sealant is applied to the circumference of all tapered male threads (ISO R); thermoplastic sealing washers are supplied on all parallel male threads (ISO G). This added feature eliminates the necessity of having to seal threads, reducing the possibility of system contamination with PTFE tape. Precote 5 thread sealant has a four year minimum shelf life, connections can be remade into the same port up to six times, it is inert, has a maximum service temperature of 180°C (350°F), and since it does not contain PTFE is accepted by the Pharmaceutical and Tobacco Industries.

Silicone Free O-rings

Silicone will migrate to product surfaces during the finishing process creating unsightly "fish eyes" that require costly rework. All O-rings used in Norgren Fittings are silicone free, a mandatory requirement of both the automotive and product finishing industry.

Nickel Plated Brass Bodies and Collets

Nickel plating gives Pneufit a uniform stainless steel like appearance, does not tarnish like brass and provides an added degree of corrosion resistance.

Size Identification

All collets or release buttons are marked with the O.D. tube size in millimeters, fractional inch, or both, providing instant tube size identification. Stem fittings have two grooves for inch and one groove for metric.

Anti-kink design (Pneufit only)

Pneufit Collets are designed to rotate freely within the fitting's body. This eliminates the troublesome kinking and twisting that can occur when tubes are retained in a rigid connection.

Maximum Flows in a Reduced Size

Maximized internal bores provide optimal flows, while forged brass bodies deliver maximum strength, reduced weights (over extruded types) and reduced envelope size.

Conveniently Packaged

Stocking and inventory are simplified because Push-In Fittings are packaged in boxes of ten, with product number, shape and sizes prominently displayed on the box.

Internationally significant part numbering system

A numbering system that identifies all aspects of the product is a standard feature, with support and availability provided world wide by a network of NORGREN distributors.

Method of Assembly

Pneufit

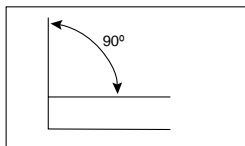

1. Ensure that the tube end is cut square and is free of burrs.

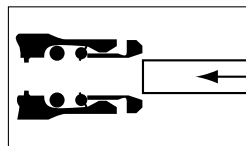

2. Push the tube through the collet into the fitting.

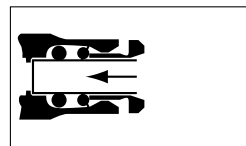

3. Continue pushing the tube (firmly) through the O-ring until it bottoms on the tube stop, then pull back

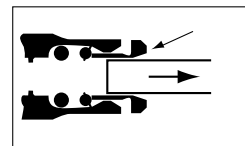

4. To disconnect, push the tube into the fitting until it bottoms on the tube stop. Then while holding down the collet, withdraw the tube.

Pneufit C

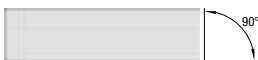

1. Ensure that the end of the tube is cut square and is free from burrs.

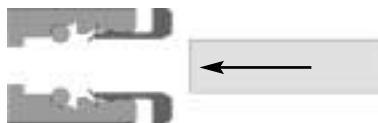

2. Push the tube through the release button and grab ring into the fitting.



3. Push the tube firmly through the 'O' ring until it bottoms on the tube stop then pull back.

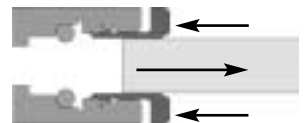

4. To disconnect, push the tube into the fitting, hold down the release button and withdraw the tube.



M5 A metric machine screw thread (M5 x 0.8) 5 mm in diameter with 0.8 mm between threads. Used on miniature pneumatic products it is nearly identical in size to a 10-32 UNF thread. Port sealing is effected by a thermoplastic washer which creates a static face seal.

ISO G Designed to mate with threads conforming to ISO Standard 228/1, a parallel pipe thread available in both male and female forms. ISO G ports feature a flat surface perpendicular to the axis of the port on which a washer incorporated into the male fitting establishes a static face seal, (reference ISO 1179).

ISO G series threads are usually designated in the following manner, with a 1/4 size pipe thread being indicated in this example: G1/4. This format is always used with female threads, however, in some, but not all instances, male threads may include an "A" or "B" suffix following the port size indicating the thread class, (typically "A"). Example: G 1/4A.

In addition to itself, the ISO G thread form will also mate with British Standard Pipe Parallel (BSPP) and Japanese Industrial Standard Parallel per JIS B 0202. As both the BSPP and JIS B 0202 standards do not define an area for the ISO G static seal to engage, some form of thread sealant must be applied to the thread to prevent spiral leakage.

ISO R Designed to mate with threads conforming to ISO Standard 7/1, a tapered pipe thread available in male form. ISO R ports are similar to NPTF threads, they form a pressure tight joint via an interference fit as they are tightened, (thread sealant is recommended). To insure a pressure tight seal, Pneufit ISO R male pipe threads are supplied with Precote 5 thread sealant.

ISO R male series threads are usually designated in the following manner, with a 1/4 size pipe thread being indicated in this example: R 1/4.

ISO R female series threads are usually designated in the same manner, but with a "c" subscript. Example: R_c1/4.

In addition to itself, the ISO R thread form will also mate with British Standard Pipe Tapered (BSPT) and Japanese Industrial Standard Tapered Pipe (PT) per JIS B 0203. Some form of thread sealant must be applied to the thread to prevent spiral leakage.

ISO R male threads will also effect a seal with ISO G, BSPP and JIS B 0202. In all cases, some form of thread sealant must be applied to the thread to prevent spiral leakage.

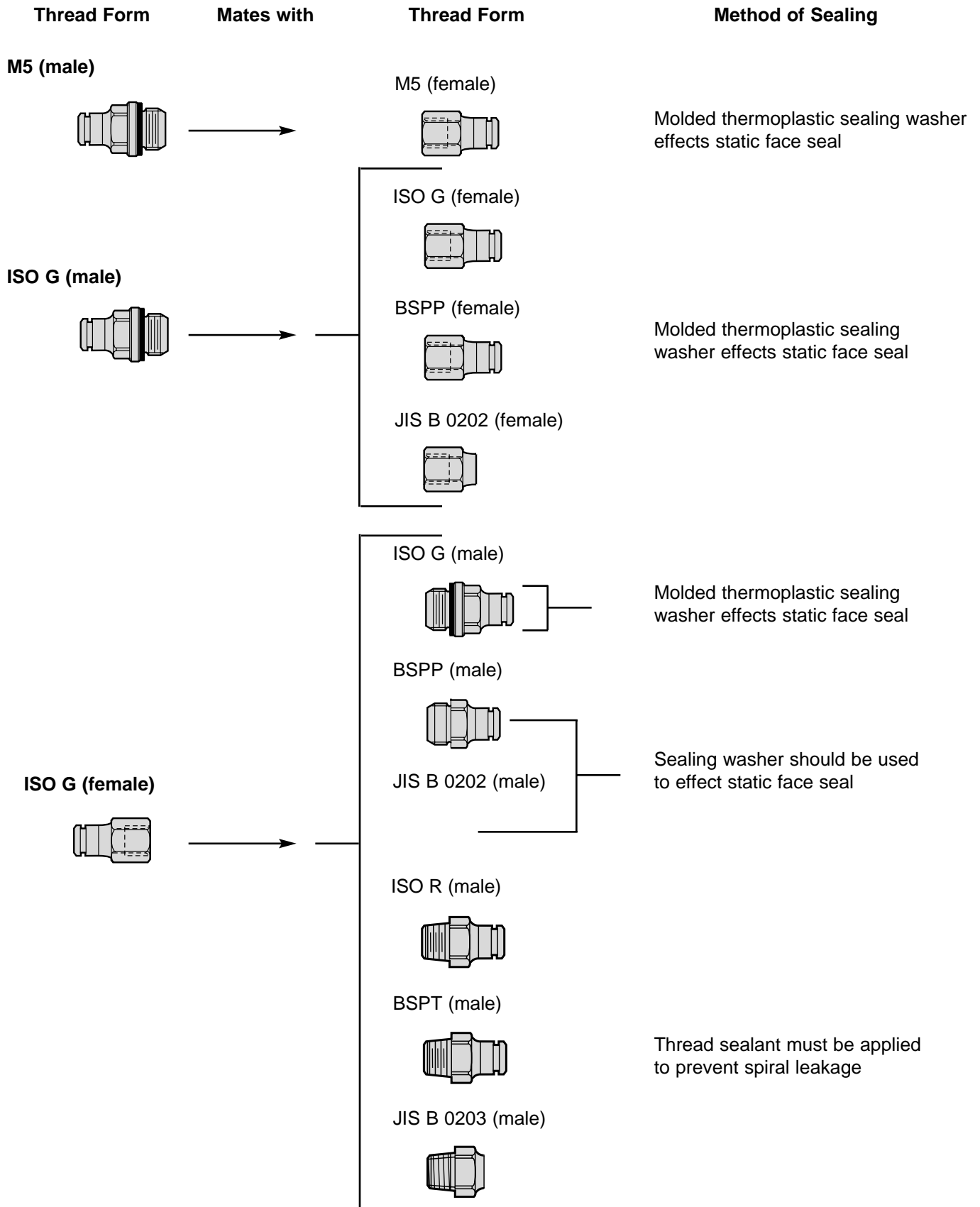



Pneufit Metric Series Mating Threads

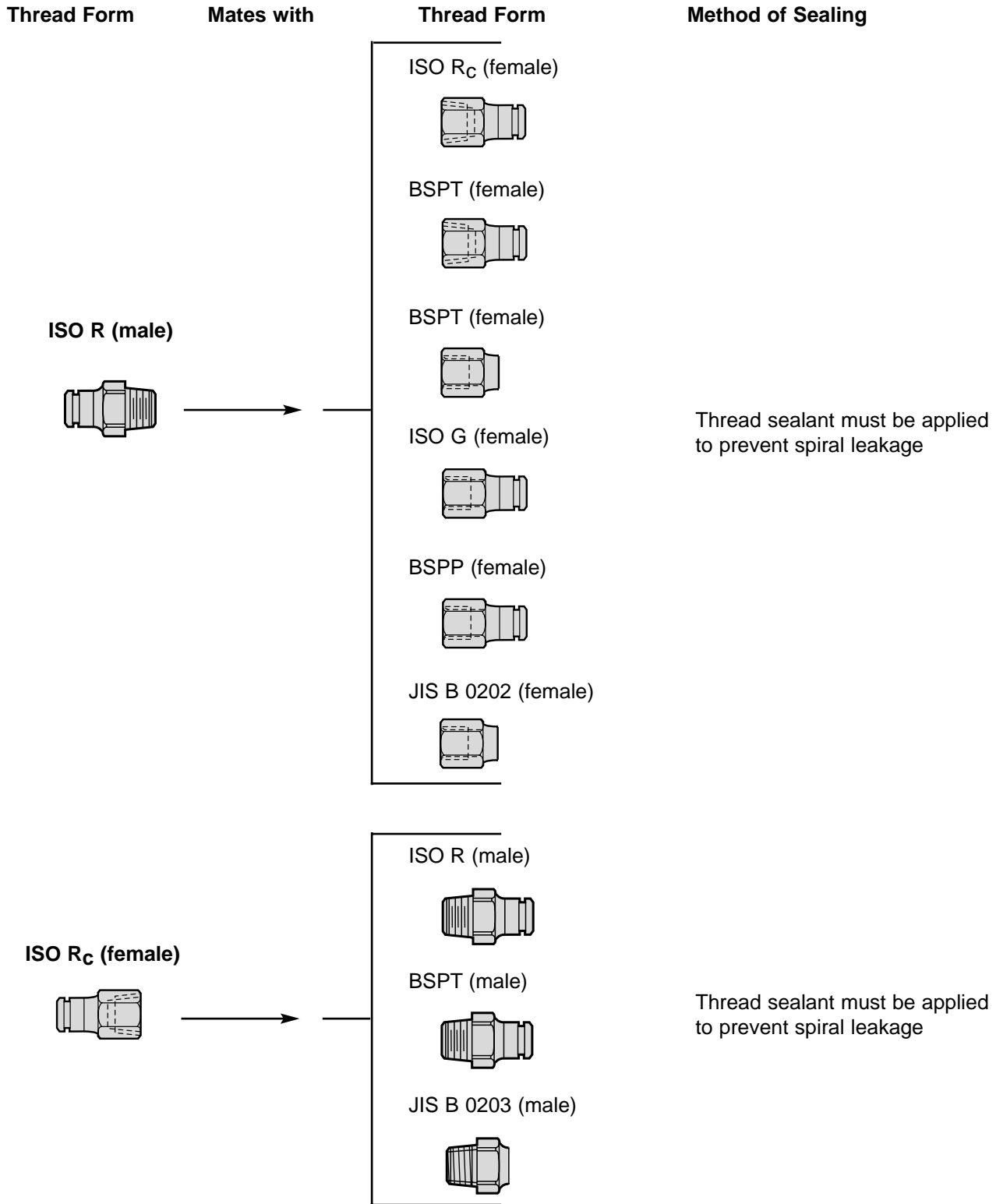



Pneufit Union

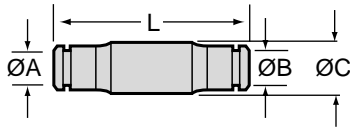

A Tube O.D.	Part Number	L	C
4	10 020 0400	29.8 (1.17)	10.0 (.39)
5	10 020 0500	31.9 (1.26)	11.0 (.43)
6	10 020 0600	32.4 (1.28)	12.0 (.47)
8	10 020 0800	34.4 (1.35)	14.0 (.55)
10	10 020 1000	43.4 (1.71)	17.0 (.67)
12	10 020 1200	50.4 (1.98)	20.5 (.81)
14	10 020 1400	50.4 (1.98)	21.0 (.83)

Pneufit Double Male Union (Brass)

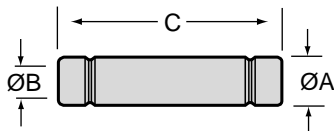

A Stem O.D.	Part Number	B	C
4	10 022 0400	2.4 (.09)	30.2 (1.19)
5	10 022 0500	3.4 (.13)	33.2 (1.31)
6	10 022 0600	4.0 (.16)	34.0 (1.34)
8	10 022 0800	6.0 (.24)	36.0 (1.42)
10	10 022 1000	7.6 (.30)	45.0 (1.77)
12	10 022 1200	9.6 (.38)	52.0 (2.05)
14	10 022 1400	11.5 (.45)	51.8 (2.04)

Pneufit Double Male Union (Plastic)

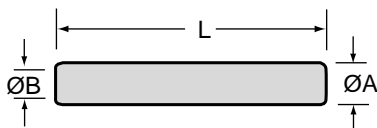

A Stem O.D.	Part Number	B	L
4	11 022 0400	2.5 (.10)	30.2 (1.19)
5	11 022 0500	3.3 (.13)	33.2 (1.31)
6	11 022 0600	4.0 (.16)	34.0 (1.34)
8	11 022 0800	5.4 (.21)	36.0 (1.42)
10	11 022 1000	7.0 (.28)	45.0 (1.77)
12	11 022 1200	8.5 (.33)	52.0 (2.05)
14	11 022 1400	11.0 (.43)	51.8 (2.04)



Metric Series Push-In Fittings

Dimensions in mm (inches)

Pneufit Conversion Union (Inch tube to mm tube)

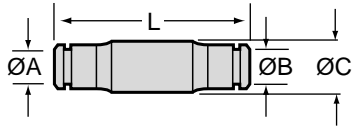

A Inch O.D.	B mm O.D.	Part Number	C	L
5/32	4	12 020 0200	9.0 (0.39)	29.8 (1.17)
3/16	5	12 037 0305	11.0 (0.43)	32.0 (1.26)
1/4	6	12 037 0406	12.0 (0.47)	32.5 (1.28)
5/16	8	12 020 0500	14.0 (0.55)	34.4 (1.35)
3/8	10	12 037 0610	17.0 (0.67)	43.4 (1.71)
1/2	12	12 037 0712	20.5 (0.81)	50.3 (1.98)

Pneufit C Conversion Union (Inch tube to mm tube)

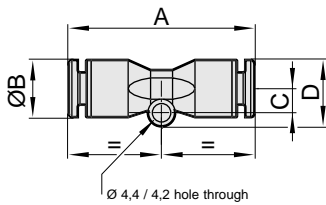

O.D. Tube	Part Number	A	B	C	D
3	C00200300	33.5	10.7	5.0	13.6
4	C002004003	3.5	10.7	5.0	13.6
6	C00200600	39.0	12.9	6.0	15.7
8	C00200800	43.5	14.5	7.0	17.5
10	C00201000	48.0	17.4	8.0	20.1



Pneufit Tube End Reducer

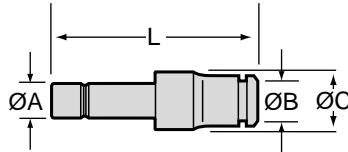

A Stem O.D.	B Tube O.D.	Part Number	L	C
5	4	10 023 0504	33.4 (1.31)	10.0 (.39)
6	4	10 023 0604	33.9 (1.33)	10.0 (.39)
	5	10 023 0605	35.2 (1.39)	11.0 (.43)
8	4	10 023 0804	30.9 (1.22)	10.0 (.39)
	5	10 023 0805	33.2 (1.31)	11.0 (.43)
	6	10 023 0806	36.7 (1.44)	12.0 (.47)
10	4	10 023 1004	30.9 (1.22)	12.0 (.47)
	5	10 023 1005	36.7 (1.44)	12.0 (.47)
	6	10 023 1006	37.7 (1.48)	12.0 (.47)
	8	10 023 1008	38.2 (1.50)	14.0 (.55)
12	4	10 023 1204	34.9 (1.37)	14.0 (.55)
	5	10 023 1205	35.2 (1.39)	14.0 (.55)
	6	10 023 1206	35.2 (1.39)	14.0 (.55)
	8	10 023 1208	42.2 (1.66)	14.0 (.55)
	10	10 023 1210	50.2 (1.98)	17.0 (.67)
14	6	10 023 1406	36.7 (1.44)	16.0 (.63)
	8	10 023 1408	37.7 (1.48)	16.0 (.63)
	10	10 023 1410	46.7 (1.84)	17.0 (.67)
	12	10 023 1412	53.7 (2.11)	20.5 (.81)

Pneufit C Tube End Reducer

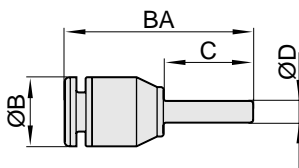

O.D. Tube	Stem	Part Number	A	B	C	D
4	5	C00230504	34.5	10.7	18	5.0
4	6	C00230604	35.5	10.7	19	6.0
4	8	C00230804	35.0	10.7	21	8.0
4	10	C00231004	37.0	10.8	24.0	10
6	4	C00230406	36.0	13.0	17	4.0
6	8	C00230806	39.5	13.0	21	8.0
6	10	C00231006	40.5	13.0	10.0	24
8	6	C00230608	40.5	14.5	19	6.0
8	10	C00231008	45.5	14.5	10.0	24



Metric Series Push-In Fittings

Dimensions in mm (inches)

Pneufit Bulkhead Union

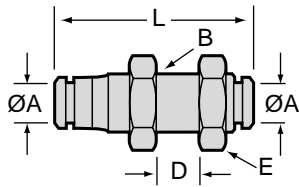

A Tube O.D.	Part Number	B Metric Thread	Panel Hole ϕ	E A/F	D Max	L
4	10 029 0400	M10x1.0	10.5 (0.42)	14 (.55)	12 (.47)	29.8 (1.17)
5	10 029 0500	M12x1.0	12.5 (0.49)	17 (.67)	14 (.55)	31.9 (1.26)
6	10 029 0600	M14x1.5	14.5 (0.57)	19 (.75)	15 (.59)	32.4 (1.28)
8	10 029 0800	M16x1.5	16.5 (0.65)	22 (.87)	16 (.63)	34.4 (1.35)
10	10 029 1000	M20x1.5	20.5 (0.81)	27 (1.06)	14 (.55)	43.4 (1.71)
12	10 029 1200	M24x1.5	24.5 (0.96)	30 (1.18)	15 (.59)	50.4 (1.98)
14	10 029 1400	M24x1.5	24.5 (0.96)	30 (1.18)	15 (.59)	50.4 (1.98)

Pneufit Union Elbow

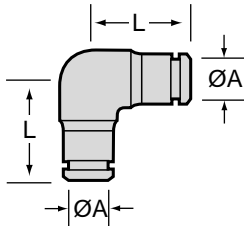

A Tube O.D.	Part Number	L
4	10 040 0400	15.5 (.61)
5	10 040 0500	18.4 (.72)
6	10 040 0600	19.6 (.77)
8	10 040 0800	21.3 (.84)
10	10 040 1000	26.7 (1.05)
12	10 040 1200	31.7 (1.25)
14	10 040 1400	33.2 (1.31)

Pneufit C Union Elbow

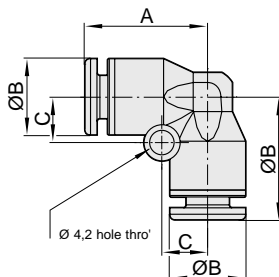

O.D. Tube	Part Number	A	B	C
3	C00400300	18.0	10.7	6.5
4	C00400400	18.0	10.7	6.5
6	C00400600	21.0	12.9	7.7
8	C00400800	25.0	14.5	7.25
10	C00401000	27.5	17.4	8.35



Pneufit Swivel Bulkhead Union Elbow

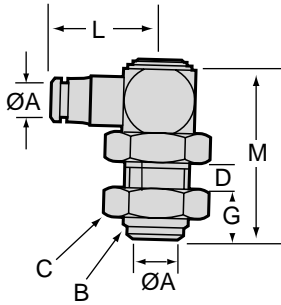

CAUTION: Swivel Adapters are not suitable for use in continuously rotating or gyrating applications.

Product Number	A Tube O.D.	M	C A/F	L	B thread	Panel Hole ø	D max	G
10 049 0400	4	35.5 (1.40)	17 (.67)	20.6 (.81)	M12x1.0	10.5 (0.42)	7 (.28)	7.0 (.28)
10 049 0500	5	35.7 (1.41)	17 (.67)	21.7 (.85)	M12x1.0	12.5 (0.49)	7 (.28)	7.2 (.28)
10 049 0600	6	40.0 (1.57)	19 (.75)	24.2 (.95)	M14x1.5	14.5 (0.57)	7 (.28)	8.2 (.32)
10 049 0800	8	45.2 (1.78)	22 (.87)	26.7 (1.05)	M16x1.5	16.5 (0.65)	7 (.28)	8.2 (.32)
10 049 1000	10	49.2 (1.94)	27 (1.06)	31.7 (1.25)	M22x1.5	20.5 (0.81)	9 (.35)	9.2 (.36)
10 049 1200	12	53.8 (2.12)	30 (1.18)	38.2 (1.50)	M24x1.5	24.5 (0.96)	12 (.47)	9.2 (.36)
10 049 1400	14	56.8 (2.24)	32 (1.26)	38.2 (1.50)	M26x1.5	24.5 (0.96)	15 (.59)	9.2 (.36)

Pneufit Stem Elbow

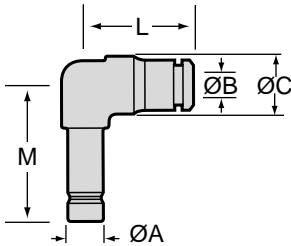

A Stem O.D.	B Tube O.D.	Part Number	C	L	M
4	4	10 043 0400	10.0 (.39)	9.4 (.37)	25.0 (.98)
6	6	10 043 0600	12.0 (.47)	18.9 (.74)	27.5 (1.08)
8	8	10 043 0800	14.0 (.55)	21.2 (.83)	29.5 (1.16)

Pneufit C Stem Elbow

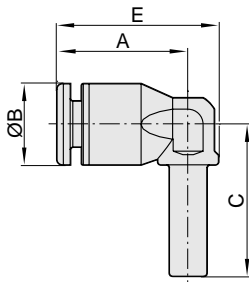

O.D. Tube	Stem	Part Number	A	B	C	E
4	4	C00430400	18.0	10.7	21.0	22.5
6	6	C00430600	21.0	12.9	24.5	26.0
8	8	C00430800	25.0	14.5	27.3	31.5



Metric Series Push-In Fittings

Dimensions in mm (inches)

Pneufit Union Tee

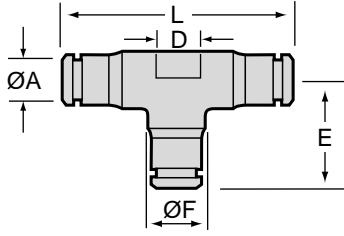

A Tube O.D.	Part Number	L	D A/F	E	F
4	10 060 0400	33.8 (1.33)	7.0 (.28)	16.9 (.67)	10.1 (.40)
5	10 060 0500	36.8 (1.45)	7.0 (.28)	18.4 (.72)	11.1 (.44)
6	10 060 0600	39.2 (1.54)	8.0 (.31)	19.6 (.77)	12.1 (.48)
8	10 060 0800	42.6 (1.68)	11.0 (.43)	21.3 (.84)	14.3 (.56)
10	10 060 1000	53.4 (2.10)	13.3 (.52)	26.7 (1.05)	17.1 (.67)
12	10 060 1200	63.4 (2.50)	16.0 (.63)	31.7 (1.25)	20.6 (.81)
14	10 060 1400	66.4 (2.61)	17.0 (.67)	33.2 (1.31)	21.6 (.85)

Pneufit C Union Tee

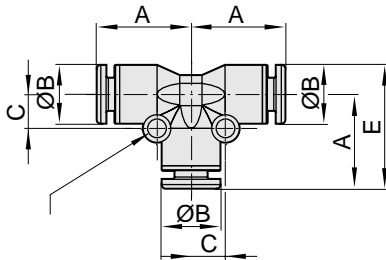

O.D. Tube	Part Number	A	B	C	E
3	C00600300	18.0	10.7	6.5	23.5
4	C00600400	18.0	10.7	6.5	23.5
6	C00600600	21.0	12.9	7.7	27.5
8	C00600800	25.0	14.5	7.25	32.5
10	C00601000	27.5	17.4	8.35	36.5



Pneufit Parallel Union "Y" Connector*

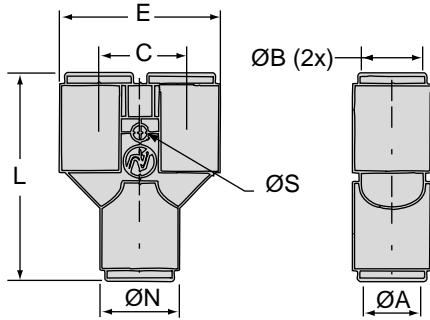

A Tube O.D.	B Tube O.D.	Part Number	C	E	L	ØN	ØS**
4	4	12 082 0200	11.0 (0.43)	22.0 (0.87)	34.0 (1.34)	11.0 (0.43)	3.2 (0.13)
6	6	10 082 0600	14.0 (0.55)	27.0 (1.06)	38.4 (1.51)	13.0 (0.51)	3.2 (0.13)
8	8	12 082 0500	16.0 (0.63)	31.0 (1.22)	40.4 (1.59)	15.0 (0.59)	3.2 (0.13)
10	10	10 082 1000	20.6 (0.81)	42.0 (1.65)	49.4 (1.94)	20.0 (0.79)	4.2 (0.17)
6	4	10 082 0604	14.0 (0.55)	27.0 (1.06)	38.2 (1.50)	13.0 (0.51)	3.2 (0.13)
8	6	10 082 0806	16.3 (0.64)	31.0 (1.22)	40.4 (1.59)	15.0 (0.59)	3.2 (0.13)
10	8	10 082 1008	20.6 (0.81)	42.0 (1.65)	49.4 (1.94)	20.0 (0.79)	4.2 (0.17)

*Body Material: Thermoplastic

** Mounting hole

Pneufit C Parallel Union "Y" Connector*

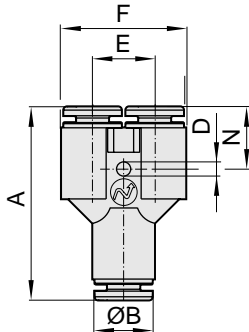

O.D. Tube	O.D. Tube	O.D. Tube	Part Number	A	B	D	E	F	N
4	4	4	C00820400	41.0	11.0	3.2	11.0	22.0	13.0
6	6	6	C00820600	43.8	14.0	3.2	14.0	28.0	14.25
6	4	4	C00820604	44.3	14.0	3.2	14.0	28.0	14.5
8	8	8	C00820800	46.7	15.0	3.2	16.0	31.0	14.9
8	6	6	C00820806	46.2	15.0	3.2	16.0	31.0	14.65
10	10	10	C00821000	57.5	20.0	4.2	20.6	42.0	14.9
10	8	8	C00821008	57.0	20.0	4.2	20.6	42.0	18.25

Pneufit C Parallel "Y" Stem Connector

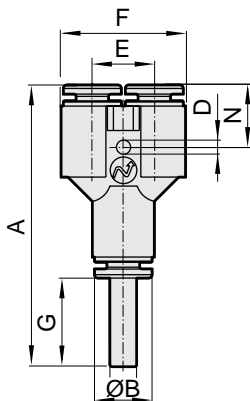

O.D. Tube	Stem	Part Number	A	B	D	E	F	G	N
4	4	C00840404	58.0	11.5	2.95	11.0	22.5	17.0	13.0
4	6	C00840604	60.0	11.5	2.95	11.0	22.5	19.0	13.0
6	6	C00840606	63.0	14.0	3.20	14.0	28.0	19.2	14.25
8	8	C00840808	68.0	16.0	3.20	16.0	32.0	21.3	14.9



Metric Series Push-In Fittings

Dimensions in mm (inches)

Pneufit ISO G Male Connector

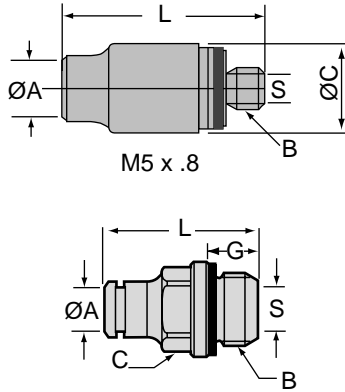

All straight male connectors have an internal hex for the use of an Allen Wrench to allow the fitting to be mounted in any position. This also permits close porting not possible with a standard open end or socket wrench.

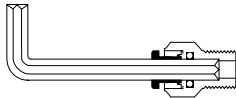

A Tube O.D.	B		C		L	S Hex
	ISO G or Metric Thread	Part Number	A/F	G		
4	M5 x .8	10 225 0405	9.0Ø (.35Ø)	5.0 (.20)	20.5 (.81)	2.5 (.10)
	1/8	10 225 0418	10 (.39)	7.2 (.28)	23.0 (.91)	3.0 (.12)
	1/4	10 225 0428	10 (.39)	9.8 (.39)	22.7 (.89)	3.0 (.12)
5	M5 x .8	10 225 0505	10.0Ø (.39Ø)	5.0 (.20)	23.2 (.91)	2.5 (.10)
	1/8	10 225 0518	10 (.39)	7.2 (.28)	23.2 (.91)	4.0 (.16)
	1/4	10 225 0528	12 (.47)	9.8 (.39)	25.2 (.99)	4.0 (.16)
6	M5 x .8	10 225 0605	11.0Ø (.43Ø)	5.0 (.20)	23.8 (.94)	2.5 (.10)
	1/8	10 225 0618	11 (.43)	7.2 (.28)	25.2 (.99)	4.0 (.16)
	1/4	10 225 0628	13 (.51)	9.8 (.39)	23.7 (.93)	4.0 (.16)
8	1/8	10 225 0818	13 (.51)	7.2 (.28)	26.7 (1.05)	5.0 (.20)
	1/4	10 225 0828	14 (.55)	9.8 (.39)	28.2 (1.11)	6.0 (.24)
	3/8	10 225 0838	17 (.67)	11.2 (.44)	26.2 (1.03)	6.0 (.24)
	1/2	10 225 0848	17 (.67)	14.7 (.58)	31.7 (1.25)	6.0 (.24)
10	1/8	10 225 1018	17 (.67)	7.2 (.28)	32.2 (1.27)	5.0 (.20)
	1/4	10 225 1028	17 (.67)	9.8 (.39)	33.7 (1.33)	7.0 (.28)
	3/8	10 225 1038	19 (.75)	11.2 (.44)	32.2 (1.27)	8.0 (.31)
	1/2	10 225 1048	19 (.75)	14.7 (.58)	32.2 (1.27)	8.0 (.31)
12	1/4	10 225 1228	22 (.87)	9.8 (.39)	37.7 (1.48)	7.0 (.28)
	3/8	10 225 1238	22 (.87)	11.2 (.44)	38.2 (1.50)	10.0 (.39)
	1/2	10 225 1248	22 (.87)	14.7 (.58)	37.2 (1.46)	10.0 (.39)
14	3/8	10 225 1438	22 (.87)	11.2 (.44)	38.2 (1.50)	10.0 (.39)
	1/2	10 225 1448	22 (.87)	14.7 (.58)	37.2 (1.46)	10.0 (.39)

Pneufit C ISO G Male Connector

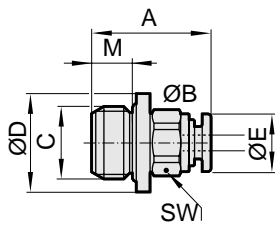

O.D.	BSPB Tube Thread	Part Number	A	C	D	E	M	SW
4	M3	C02250403	19.2	M3	10.6	10.7	3.5	1.5
4	M5	C02250405	21.2	M5	10.6	10.7	4.4	2.5
4	1/8"	C02250418	18.7	1/8"	13.8	12.0	5.5	3.0
4	1/4"	C02250428	21.5	1/4"	17.8	12.0	8.0	3.0
6	M5	C02250605	24.6	M5	12.6	12.9	4.4	2.5
6	1/8"	C02250618	24.1	1/8"	13.8	14.0	5.5	4.0
6	1/4"	C02250628	23.1	1/4"	17.8	14.0	8.0	4.0
8	1/8"	C02250818	27.0	1/8"	13.8	16.0	5.5	5.0
8	1/4"	C02250828	25.0	1/4"	17.8	16.0	8.0	6.0
8	3/8"	C02250838	25.0	3/8"	21.7	16.0	9.0	6.0
8	1/2"	C02250848	27.5	1/2"	25.7	16.0	11.1	6.0
10	1/8"	C02251018	28.1	1/8"	13.8	21.0	5.5	5.0
10	1/4"	C02251028	31.1	1/4"	17.8	21.0	8.0	7.0
10	3/8"	C02251038	28.1	3/8"	21.7	21.0	9.0	8.0
10	1/2"	C02251048	30.1	1/2"	25.7	21.0	11.1	8.0

Metric Series Push-In Fittings

Dimensions in mm (inches)



Pneufit ISO R Male Connector

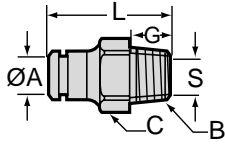

All straight male connectors have an internal hex for the use of an Allen Wrench to allow the fitting to be mounted in any position. This also permits close porting not possible with a standard open end or socket wrench.

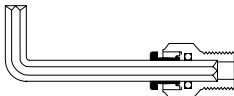

A Tube O.D.	B ISO R Thread	Part Number	C A/F	G	L	S Hex
4	1/8	10 125 0418	10 (.39)	7.7 (.30)	20.5 (.81)	3.0 (.12)
	1/4	10 125 0428	14 (.55)	11.1 (.44)	23.0 (.91)	3.0 (.12)
5	1/8	10 125 0518	10 (.39)	7.7 (.30)	22.7 (.89)	4.0 (.16)
	1/4	10 125 0528	14 (.55)	11.1 (.44)	23.2 (.91)	4.0 (.16)
6	1/8	10 125 0618	11 (.43)	7.7 (.30)	23.2 (.91)	4.0 (.16)
	1/4	10 125 0628	14 (.55)	11.1 (.44)	25.2 (.99)	4.0 (.16)
8	1/8	10 125 0818	13 (.51)	7.7 (.30)	26.7 (1.05)	5.0 (.20)
	1/4	10 125 0828	14 (.55)	11.1 (.44)	28.2 (1.11)	6.0 (.24)
	3/8	10 125 0838	17 (.67)	12.7 (.50)	27.2 (1.07)	6.0 (.24)
	1/2	10 125 0848	22 (.87)	15.9 (.63)	29.2 (1.15)	6.0 (.24)
10	1/8	10 125 1018	17 (.67)	7.7 (.30)	31.7 (1.25)	5.0 (.20)
	1/4	10 125 1028	17 (.67)	11.1 (.44)	34.2 (1.35)	7.0 (.28)
	3/8	10 125 1038	17 (.67)	12.7 (.50)	34.2 (1.35)	8.0 (.31)
	1/2	10 125 1048	22 (.87)	15.9 (.63)	33.7 (1.33)	8.0 (.31)
12	1/4	10 125 1228	22 (.87)	11.1 (.44)	39.2 (1.54)	7 (.28)
	3/8	10 125 1238	22 (.87)	12.7 (.50)	39.7 (1.56)	10 (.39)
	1/2	10 125 1248	22 (.87)	15.9 (.63)	40.2 (1.58)	10 (.39)
14	3/8	10 125 1438	22 (.87)	12.7 (.50)	39.7 (1.56)	10 (.39)
	1/2	10 125 1448	22 (.87)	15.9 (.63)	40.2 (1.58)	10 (.39)

Pneufit C ISO R Male Connector

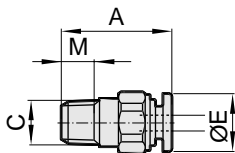

O.D. Tube	BSPT Thread	Part Number	A	C	E	M
4	1/8"	C01250418	19.7	1/8"	12.0	8.6
4	1/4"	C01250428	23.2	1/4"	15.0	11.1
6	1/8"	C01250618	25.1	1/8"	14.0	8.6
6	1/4"	C01250628	23.1	1/4"	15.0	11.1
8	1/8"	C01250818	28.6	1/8"	16.0	8.6
8	1/4"	C01250828	26.1	1/4"	16.0	11.1
8	3/8"	C01250838	26.1	3/8"	18.5	12.7
8	1/2"	C01250848	31.6	1/2"	24.0	15.9
10	1/8"	C01251018	30.1	1/8"	21.0	8.6
10	1/4"	C01251028	32.1	1/4"	21.0	11.1
10	3/8"	C01251038	29.6	3/8"	21.0	12.7
10	1/2"	C01251048	33.1	1/2"	24.0	15.9



Metric Series Push-In Fittings

Dimensions in mm (inches)

Pneufit Male Connector - Conversion (MM O.D. Tube to NPTF [Male] Thread)

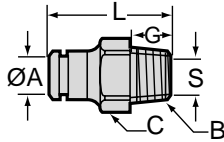

All straight male connectors have an internal hex for the use of an Allen Wrench to allow the fitting to be mounted in any position. This also permits close porting not possible with a standard open end or socket wrench.

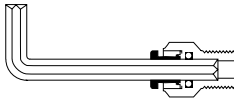

A Tube O.D.	B NPT Thread	Part Number	C A/F	G	L	S Hex
4	10-32	12 425 0210	9.0 (3.5)	5.0 (.20)	21.5 (.85)	3/32" —
	1/8	12 425 0218	11.1 (7/16")	9.5 (.37)	22.7 (.89)	1/8" —
	1/4	12 425 0228	14.3 (9/16")	14.3 (.56)	26.5 (1.04)	1/8" —
5	1/8	10 425 0518	11.1 (7/16")	9.5 (.37)	24.5 (.96)	5/32" —
	1/4	10 425 0528	14.3 (9/16")	14.3 (.56)	26.3 (1.04)	5/32" —
6	10-32	10 425 0610	11.0 (.43)	5.0 (.20)	24 (.94)	3/32" —
	1/8	10 425 0618	11.1 (7/16")	9.5 (.37)	25.0 (.98)	5/32" —
	1/4	10 425 0628	14.3 (9/16")	14.3 (.56)	28.3 (1.11)	5/32" —
	3/8	10 425 0638	17.5 (11/16")	14.3 (.56)	27.2 (1.07)	5/32" —
8	1/8	12 425 0518	12.7 (1/2")	9.5 (.37)	28.5 (1.12)	3/16" —
	1/4	12 425 0528	14.3 (9/16")	14.3 (.56)	31.3 (1.23)	1/4" —
	3/8	12 425 0538	17.5 (11/16")	14.3 (.56)	28.8 (1.13)	1/4" —
10	1/8	10 425 1018	17.5 (11/16")	9.5 (.37)	33.5 (1.32)	3/16" —
	1/4	10 425 1028	17.5 (11/16")	14.3 (.56)	37.3 (1.47)	1/4" —
	3/8	10 425 1038	17.5 (11/16")	14.3 (.56)	35.8 (1.41)	5/16" —
	1/2	10 425 1048	22.2 (7/8")	19.0 (.75)	36.8 (1.45)	5/16" —
12	1/4	10 425 1228	22.2 (7/8")	14.3 (.56)	42.3 (1.67)	9/32" —
	3/8	10 425 1238	22.2 (7/8")	14.3 (.56)	41.3 (1.63)	13/32" —
	1/2	10 425 1248	22.2 (7/8")	19.0 (.75)	43.3 (1.70)	13/32" —

Self Sealing (Checked) Connector (ISO R)

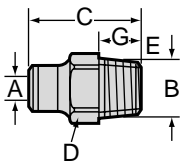

A Tube O.D.	B ISO R Thread	Part Number	C	D A/F	G
4	1/8	10 124 0418	25.5 (1.00)	11 (0.43)	8.6 (0.34)
6	1/8	10 124 0618	27.5 (1.08)	11 (0.43)	8.6 (0.34)
6	1/4	10 124 0628	27.5 (1.08)	14 (0.55)	11.1 (0.44)
8	1/4	10 124 0828	32.7 (1.29)	14 (0.55)	11.1 (0.44)

Operation: Insertion of a tube into the push-in end ("A") of the fitting compresses a spring, and unseats the plunger and seal assembly. In this state (tube inserted), flow is allowed through the fitting. Removal of the tubing from the fitting allows the spring to extend, seating the plunger seal. When pressure is applied to the system, the plunger assembly seals off the push-in end of the fitting, allowing the system to remain pressurized.

Note: Remember to depressurize the system before inserting or removing tubing from this or any other Pneufit.



Pneufit ISO G Stem Adapter

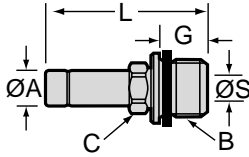

CAUTION: Straight Stem Adapters should not be used in conjunction with other union type fittings in applications where vibration is present, nor should they be used as “quick disconnects” as the mating nickel plated brass surfaces may wear over time causing eventual failure of the connection.

A Stem O.D.	B ISO G Thread	Part Number	C A/F	G	L	S
4	1/8	10 215 0418	8 (.31)	7.2 (.28)	29.0 (1.14)	2.1 (.08)
	1/4	10 215 0428	10 (.39)	9.8 (.39)	33.0 (1.30)	2.1 (.08)
5	1/8	10 215 0518	8 (.31)	7.2 (.28)	30.5 (1.20)	3.3 (.13)
	1/4	10 215 0528	10 (.39)	9.8 (.39)	34.0 (1.34)	3.3 (.13)
6	1/8	10 215 0618	8 (.31)	7.2 (.28)	31.0 (1.22)	4.0 (.16)
	1/4	10 215 0628	10 (.39)	9.8 (.39)	34.5 (1.36)	4.0 (.16)
8	1/8	10 215 0818	10 (.39)	7.2 (.28)	32.5 (1.28)	5.0 (.20)
	1/4	10 215 0828	10 (.39)	9.8 (.39)	35.5 (1.40)	6.0 (.24)
	3/8	10 215 0838	13 (.51)	11.2 (.44)	39.0 (1.54)	6.0 (.24)
10	1/4	10 215 1028	13 (.51)	9.8 (.39)	41.5 (1.63)	6.5 (.26)
	3/8	10 215 1038	13 (.51)	11.2 (.44)	43.5 (1.71)	8.0 (.31)
	1/2	10 215 1048	17 (.67)	14.8 (.58)	49.0 (1.93)	8.0 (.31)
12	3/8	10 215 1238	17 (.67)	11.2 (.44)	48.5 (1.91)	10.0 (.39)
	1/2	10 215 1248	17 (.67)	14.8 (.58)	52.5 (2.07)	10.0 (.39)
14	1/2	10 215 1448	17 (.67)	14.8 (.58)	52.5 (2.07)	11.5 (.45)

Pneufit C ISO G Stem Adapter

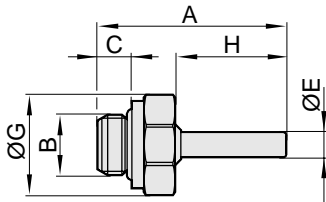

O.D.	BSP	Part Number	A	B	C	E	G	H
4	1/8"	C02150418	30.5	1/8"	5.5	4.0	14.0	17.0
4	1/4"	C02150428	35.5	1/4"	8.0	4.0	18.0	17.0
5	1/8"	C02150518	31.5	1/8"	5.5	5.0	14.0	18.0
5	1/4"	C02150528	36.5	1/4"	8.0	5.0	18.0	18.0
6	1/8"	C02150618	32.5	1/8"	5.5	6.0	14.0	19.0
6	1/4"	C02150628	37.5	1/4"	8.0	6.0	18.0	19.0
8	1/8"	C02150818	34.0	1/8"	5.5	8.0	14.0	20.0
8	1/4"	C02150828	38.5	1/4"	8.0	8.0	18.0	20.0
8	3/8"	C02150838	41.5	3/8"	9.0	8.0	22.0	20.0
10	1/4"	C02151028	42.5	1/4"	8.0	10.0	18.0	24.0
10	3/8"	C02151038	45.5	3/8"	9.0	10.0	22.0	24.0
10	1/2"	C02151048	50.0	1/2"	11.0	10.0	26.0	24.0



Metric Series Push-In Fittings

Dimensions in mm (inches)

Pneufit ISO R Stem Adapter

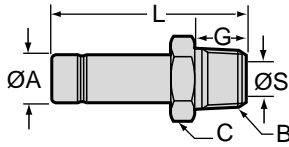

CAUTION: Straight Stem Adapters should not be used in conjunction with other union type fittings in applications where vibration is present, nor should they be used as "quick disconnects" as the mating nickel plated brass surfaces may wear over time causing eventual failure of the connection.

A Stem O.D.	B ISO R Thread	Part Number	C A/F	G	L	S
4	1/8	10 115 0418	10 (.39)	7.7 (.30)	30.0 (1.18)	2.1 (.08)
	1/4	10 115 0428	14 (.55)	11.1 (.44)	33.5 (1.32)	2.1 (.08)
5	1/8	10 115 0518	11 (.43)	7.7 (.30)	31.0 (1.22)	3.5 (.14)
	1/4	10 115 0528	14 (.55)	11.1 (.44)	35.0 (1.38)	3.5 (.14)
6	1/8	10 115 0618	12 (.47)	7.7 (.30)	32.0 (1.26)	4.5 (.18)
	1/4	10 115 0628	14 (.55)	11.1 (.44)	35.5 (1.40)	4.5 (.18)
8	1/8	10 115 0818	14 (.55)	7.7 (.30)	33.0 (1.30)	5.1 (.20)
	1/4	10 115 0828	14 (.55)	11.1 (.44)	36.5 (1.44)	5.1 (.20)
	3/8	10 115 0838	19 (.75)	12.7 (.50)	40.0 (1.57)	5.1 (.20)
10	1/4	10 115 1028	15 (.59)	11.1 (.44)	40.0 (1.57)	7.7 (.30)
	3/8	10 115 1038	19 (.75)	12.7 (.50)	45.0 (1.77)	7.7 (.30)
	1/2	10 115 1048	22 (.87)	15.9 (.63)	48.0 (1.89)	8.1 (.32)
12	3/8	10 115 1238	19 (.75)	12.7 (.50)	48.0 (1.89)	9.1 (.36)
	1/2	10 115 1248	22 (.87)	15.9 (.63)	51.5 (2.03)	9.1 (.36)
14	1/2	10 115 1448	22 (.87)	15.9 (.63)	51.4 (2.02)	11.2 (.44)

Pneufit C ISO R Stem Adapter

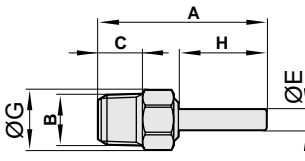

O.D.	BSP	Part Number	A	B	C	E	G	H
4	1/8"	C01150418	32.5	1/8"	8.6	4.0	11.0	17.0
4	1/4"	C01150428	35.0	1/4"	11.1	4.0	15.0	17.0
5	1/8"	C01150518	33.5	1/8"	8.6	5.0	11.0	18.0
5	1/4"	C01150528	36.0	1/4"	11.1	5.0	15.0	18.0
6	1/8"	C01150618	34.5	1/8"	8.6	6.0	11.0	19.0
6	1/4"	C01150628	37.0	1/4"	11.1	6.0	15.0	19.0
8	1/8"	C01150818	36.0	1/8"	8.6	8.0	13.0	20.0
8	1/4"	C01150828	38.0	1/4"	11.1	8.0	15.0	20.0
8	3/8"	C01150838	42.0	3/8"	12.7	8.0	20.0	20.0
10	1/4"	C01151028	43.0	1/4"	11.1	10.0	15.0	24.0
10	3/8"	C01151038	45.5	3/8"	12.7	10.0	20.0	24.0
10	1/2"	C01151048	49.0	1/2"	15.9	10.0	23.0	24.0
12	3/8"	C01151238	49.5	3/8"	12.7	12.0	20.0	27.5
12	1/2"	C01151248	52.5	1/2"	15.9	12.0	23.0	27.5
14	1/2"	C01151448	53.0	1/2"	15.9	14.0	23.0	28.0



Stem Adapter

(Inch O.D. Stem to ISO R Thread)

- Incorporates standard Pneufit features.
- Allows integration of standard NPTF ported products into metric systems
- Connects metric port forms to fractional inch size tubing, or NPT ports to millimeter size tubing.
- By combining Straight Stem Adapters with Standard inch (12-Series) push-in tube unions, you can create a variety of combinations. (See box at right.)

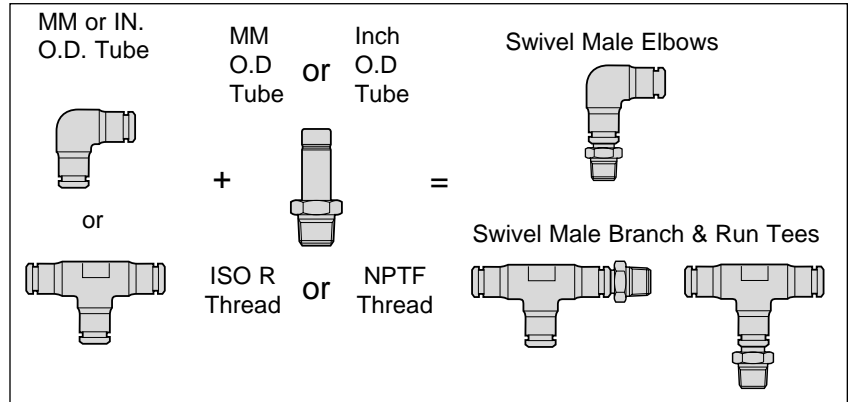

Pneufit Stem Adapter

(MM O.D. Stem to NPT [Male] Thread)

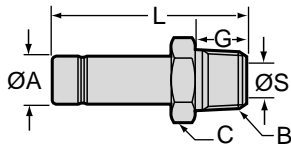

CAUTION: Straight Stem Adapters should not be used in conjunction with other union type fittings in applications where vibration is present, nor should they be used as "quick disconnects" as the mating nickel plated brass surfaces may wear over time causing eventual failure of the connection.

A Stem O.D.	B NPT Thread	Part Number	C A/F	G	L	S
4	1/8	12 415 0218	(11.1) 7/16"	9.5 (.37)	31.8 (1.25)	2.1 (.08)
	1/4	12 415 0228	(14.3) 9/16"	14.3 (.56)	36.7 (1.44)	2.1 (.08)
5	1/8	10 415 0518	(11.1) 7/16"	9.5 (.37)	33.3 (1.31)	3.2 (.13)
	1/4	10 415 0528	(14.3) 9/16"	14.3 (.56)	38.2 (1.50)	3.2 (.13)
6	1/8	10 415 0618	(11.1) 7/16"	9.5 (.37)	33.7 (1.33)	4.0 (.16)
	1/4	10 415 0628	(14.3) 9/16"	14.3 (.56)	38.6 (1.52)	4.0 (.16)
8	1/8	12 415 0518	(11.1) 7/16"	9.5 (.37)	34.8 (1.37)	5.1 (.20)
	1/4	12 415 0528	(14.3) 9/16"	14.3 (.56)	39.6 (1.56)	5.1 (.20)
10	1/4	10 415 1028	(14.3) 9/16"	14.3 (.56)	44.1 (1.74)	7.7 (.30)
	3/8	10 415 1038	(17.5) 11/16"	14.3 (.56)	46.1 (1.81)	7.7 (.30)
12	3/8	10 415 1238	(17.5) 11/16"	14.3 (.56)	49.6 (1.95)	9.1 (.36)
	1/2	10 415 1248	(22.2) 7/8"	19.0 (.75)	54.6 (2.15)	9.1 (.36)



Metric Series Push-In Fittings

Dimensions in mm (inches)

Pneufit ISO G Female Connector

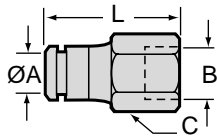

A Tube O.D.	B ISO G or Metric Thread	Part Number	C A/F	L
4	M5 x .8	10 226 0405	10 (.39)	22.5 (.89)
	1/8	10 226 0418	13 (.51)	24.4 (.96)
	1/4	10 226 0428	17 (.67)	29.2 (1.15)
5	1/8	10 226 0518	13 (.51)	25.2 (.99)
	1/4	10 226 0528	17 (.67)	29.7 (1.17)
6	1/8	10 226 0618	13 (.51)	25.7 (1.01)
	1/4	10 226 0628	17 (.67)	30.2 (1.19)
8	1/8	10 226 0818	13 (.51)	26.7 (1.05)
	1/4	10 226 0828	17 (.67)	31.2 (1.23)
10	1/4	10 226 1028	17 (.67)	35.7 (1.41)
	3/8	10 226 1038	19 (.75)	41.2 (1.62)
12	3/8	10 226 1238	19 (.75)	39.6 (1.56)
	1/2	10 226 1248	24 (.94)	44.2 (1.74)

Pneufit C ISO G Female Connector

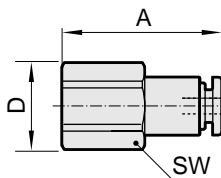

O.D. Tube	ISO R Thread	Part Number	A	D	SW
4	M5	C02260405	22.5	12.0	11.0
4	1/8"	C02260418	25.2	14.0	13.0
4	1/4"	C02260428	29.7	18.5	17.0
6	1/8"	C02260618	27.1	14.0	13.0
6	1/4"	C02260628	31.6	18.5	17.0
8	1/8"	C02260818	29.1	16.0	15.0
8	1/4"	C02260828	34.1	18.5	17.0
8	1/4"	C02261028	29.5	21.0	19.0
8	3/8"	C02261038	29.5	21.0	19.0

Metric Series Push-In Fittings

Dimensions in mm (inches)



Pneufit ISO R Male Elbow

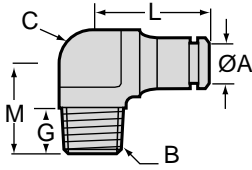

A Tube O.D.	B ISO R Thread	Part Number	C A/F	G	L	M
4	1/8	10 145 0418	7 (.28)	7.7 (.30)	16.9 (.67)	15.0 (.59)
	1/4	10 145 0428	11 (.43)	11.1 (.44)	18.2 (.72)	20.2 (.80)
5	1/8	10 145 0518	7 (.28)	7.7 (.30)	18.4 (.72)	15.5 (.61)
	1/4	10 145 0528	11 (.43)	11.1 (.44)	20.0 (.79)	20.2 (.80)
6	1/8	10 145 0618	8 (.31)	7.7 (.30)	19.6 (.77)	16.0 (.63)
	1/4	10 145 0628	11 (.43)	11.1 (.44)	20.0 (.79)	20.2 (.80)
8	1/8	10 145 0818	11 (.43)	7.7 (.30)	21.3 (.84)	16.9 (.67)
	1/4	10 145 0828	11 (.43)	11.1 (.44)	21.3 (.84)	20.2 (.80)
	3/8	10 145 0838	13.3 (.52)	12.7 (.50)	22.0 (.87)	23.3 (.92)
	1/2	10 145 0848	17 (.67)	15.9 (.63)	24.2 (.95)	28.8 (1.13)
10	1/8	10 145 1018	13.3 (.52)	7.7 (.30)	26.7 (1.05)	18.5 (.73)
	1/4	10 145 1028	13.3 (.52)	11.1 (.44)	26.7 (1.05)	21.6 (.85)
	3/8	10 145 1038	13.3 (.52)	12.7 (.50)	26.7 (1.05)	23.3 (.92)
	1/2	10 145 1048	17 (.67)	15.9 (.63)	28.7 (1.13)	28.8 (1.13)
12	1/4	10 145 1228	16 (.63)	11.1 (.44)	31.7 (1.25)	23.3 (.92)
	3/8	10 145 1238	16 (.63)	12.7 (.50)	31.7 (1.25)	25.0 (.98)
	1/2	10 145 1248	17 (.67)	15.9 (.63)	32.2 (1.27)	28.8 (1.13)



Metric Series Push-In Fittings

Dimensions in mm (inches)

Pneufit ISO G Swivel Male Elbow

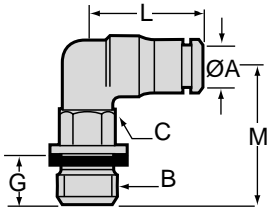

CAUTION: Swivel adapters are not suitable for use in continuously rotating or gyrating applications.

A Tube O.D.	B ISO G or Metric Thread	Part Number	C			
			A/F	G	L	M
4	M5 x .8	10 247 0405	8 (.31)	5.0 (.20)	17.0 (.67)	19.5 (.77)
	1/8	10 247 0418	11 (.43)	7.2 (.28)	16.9 (.67)	21.8 (.86)
	1/4	10 247 0428	11 (.43)	9.8 (.39)	16.9 (.67)	25.5 (1.00)
5	M5 x .8	10 247 0505	8 (.31)	5.0 (.20)	18.4 (.72)	20.0 (.79)
	1/8	10 247 0518	11 (.43)	7.2 (.28)	18.4 (.72)	22.3 (.88)
	1/4	10 247 0528	11 (.43)	9.8 (.39)	18.4 (.72)	26.0 (1.02)
6	M5 x .8	10 247 0605	8 (.31)	5.0 (.20)	19.6 (.77)	20.5 (.81)
	1/8	10 247 0618	11 (.43)	7.2 (.28)	19.6 (.77)	22.8 (.90)
	1/4	10 247 0628	11 (.43)	9.8 (.39)	19.6 (.77)	26.5 (1.04)
8	1/8	10 247 0818	13 (.51)	7.2 (.28)	21.3 (.84)	23.8 (.94)
	1/4	10 247 0828	17 (.67)	9.8 (.39)	21.3 (.84)	29.1 (1.15)
	3/8	10 247 0838	19 (.75)	11.2 (.44)	21.8 (.86)	33.3 (1.31)
	1/2	10 247 0848	19 (.75)	14.7 (.58)	21.8 (.86)	39.3 (1.55)
10	1/8	10 247 1018	17 (.67)	7.2 (.28)	26.7 (1.05)	26.3 (1.04)
	1/4	10 247 1028	17 (.67)	9.8 (.39)	26.7 (1.05)	31.6 (1.24)
	3/8	10 247 1038	19 (.75)	11.2 (.44)	26.7 (1.05)	33.3 (1.31)
	1/2	10 247 1048	19 (.75)	14.7 (.58)	26.7 (1.05)	39.3 (1.55)
12	1/4	10 247 1228	19 (.75)	9.8 (.39)	31.7 (1.25)	35.3 (1.39)
	3/8	10 247 1238	19 (.75)	11.2 (.44)	31.7 (1.25)	37.0 (1.46)
	1/2	10 247 1248	19 (.75)	14.7 (.58)	31.7 (1.25)	43.0 (1.69)
14	3/8	10 247 1438	19 (.75)	11.2 (.44)	30.7 (1.21)	36.0 (1.42)
	1/2	10 247 1448	24 (.94)	14.7 (.58)	31.7 (1.25)	39.2 (1.54)

Pneufit C ISO G Swivel Male Elbow

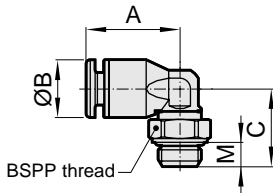

O.D. Tube	BSPB Thread	Part Number	A	B	C	M
3	1/8"	C02470318	18.0	10.7	20.0	5.5
4	M5	C02470405	18.0	10.7	17.5	4.36
4	1/8"	C02470418	18.0	10.7	20.0	5.5
4	1/4"	C02470428	18.0	10.7	23.0	8.0
6	M5	C02470605	21.0	12.9	18.5	4.36
6	1/8"	C02470618	21.0	12.9	20.5	5.5
6	1/4"	C02470628	21.0	12.9	23.5	5.5
8	1/4"	C02470828	25.0	14.5	25.5	8.0
8	3/8"	C02470838	25.0	14.5	26.5	9.0
10	3/8"	C02471038	27.5	17.4	28.5	9.0



Pneufit ISO R Swivel Male Elbow

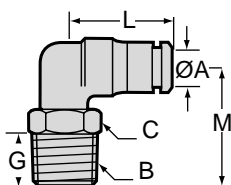

CAUTION: Swivel adapters are not suitable for use in continuously rotating or gyrating applications.

A Tube O.D.	B ISO R Thread	Part Number	C A/F	G	L	M
4	1/8	10 147 0418	10 (.39)	7.7 (.30)	16.9 (.67)	20.5 (.81)
	1/4	10 147 0428	14 (.55)	11.1 (.44)	16.9 (.67)	24.1 (.95)
5	1/8	10 147 0518	11 (.43)	7.7 (.30)	18.4 (.72)	21.0 (.83)
	1/4	10 147 0528	14 (.55)	11.1 (.44)	18.4 (.72)	24.6 (.97)
6	1/8	10 147 0618	11 (.43)	7.7 (.30)	19.6 (.77)	21.5 (.85)
	1/4	10 147 0628	14 (.55)	11.1 (.44)	19.6 (.77)	25.1 (.99)
	3/8	10 147 0638	17 (.67)	12.7 (.50)	20.0 (.80)	27.5 (1.08)
8	1/8	10 147 0818	14 (.55)	7.7 (.30)	21.3 (.84)	23.0 (.91)
	1/4	10 147 0828	14 (.55)	11.1 (.44)	21.3 (.84)	26.1 (1.03)
	3/8	10 147 0838	17 (.67)	12.7 (.50)	21.8 (.86)	30.5 (1.20)
	1/2	10 147 0848	22 (.87)	15.9 (.63)	21.8 (.86)	34.5 (1.36)
10	1/8	10 147 1018	14 (.55)	7.7 (.30)	26.7 (1.05)	25.5 (1.0)
	1/4	10 147 1028	17 (.67)	11.1 (.44)	26.7 (1.05)	28.8 (1.13)
	3/8	10 147 1038	17 (.67)	12.7 (.50)	26.7 (1.05)	30.5 (1.20)
	1/2	10 147 1048	22 (.87)	15.9 (.63)	26.7 (1.05)	34.5 (1.36)
12	1/4	10 147 1228	19 (.75)	11.1 (.44)	31.7 (1.25)	31.8 (1.25)
	3/8	10 147 1238	22 (.87)	12.7 (.50)	31.7 (1.25)	34.2 (1.35)
	1/2	10 147 1248	22 (.87)	15.9 (.63)	31.7 (1.25)	38.2 (1.50)
14	3/8	10 147 1438	22 (.87)	12.7 (.50)	30.7 (1.21)	33.2 (1.31)
	1/2	10 147 1448	22 (.87)	15.9 (.63)	31.7 (1.25)	37.0 (1.46)

Pneufit C ISO R Swivel Male Elbow

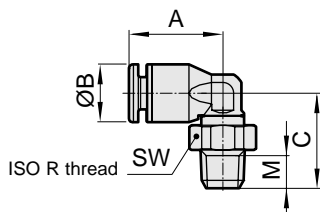

O.D. Tube	ISO R Thread	Part Number	A	B	C	SW	M
3	1/8"	C01470318	18.0	10.7	19.5	10.0	8.6
4	1/8"	C01470418	18.0	10.7	19.5	10.0	8.6
4	1/4"	C01470428	18.0	10.7	20.5	14.0	11.1
6	1/8"	C01470618	21.0	12.9	21.0	10.0	8.6
6	1/4"	C01470628	21.0	12.9	24.0	14.0	11.1
6	3/8"	C01470638	21.0	12.9	26.0	17.0	12.7
8	1/4"	C01470828	25.0	14.5	25.0	14.0	11.1
8	3/8"	C01470838	25.0	14.5	26.5	17.0	12.7
10	3/8"	C01471038	27.5	17.4	28.5	17.0	12.7



Metric Series Push-In Fittings

Dimensions in mm (inches)

Pneufit ISO G Swivel Male Branch Tee

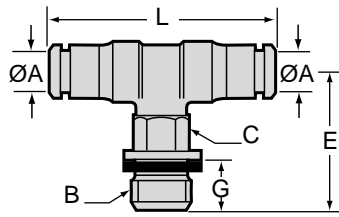

CAUTION: Swivel adapters are not suitable for use in continuously rotating or gyrating applications.

A Tube O.D.	B ISO G or Metric Thrd	Part Number	C A/F	G	L	E
4	M5 x .8	10 267 0405	8 (.31)	5.0 (.20)	34.0 (1.34)	19.5 (.77)
	1/8	10 267 0418	11 (.43)	7.2 (.28)	33.8 (1.33)	21.8 (.86)
5	M5 x .8	10 267 0505	8 (.31)	5.0 (.20)	36.8 (1.45)	20.0 (.79)
	1/8	10 267 0518	11 (.43)	7.2 (.28)	36.8 (1.45)	22.3 (.88)
	1/4	10 267 0528	11 (.43)	9.8 (.39)	36.8 (1.45)	26.0 (1.02)
6	M5 x .8	10 267 0605	8 (.31)	5.0 (.20)	39.2 (1.54)	20.5 (.81)
	1/8	10 267 0618	11 (.43)	7.2 (.28)	39.2 (1.54)	22.8 (.90)
	1/4	10 267 0628	11 (.43)	9.8 (.39)	39.2 (1.54)	26.5 (1.04)
8	1/8	10 267 0818	13 (.51)	7.2 (.28)	42.6 (1.68)	23.8 (.94)
	1/4	10 267 0828	17 (.67)	9.8 (.39)	42.6 (1.68)	29.1 (1.15)
10	1/4	10 267 1028	17 (.67)	9.8 (.39)	53.4 (2.10)	31.6 (1.24)
	3/8	10 267 1038	19 (.75)	11.2 (.44)	53.4 (2.10)	33.3 (1.31)
12	1/4	10 267 1228	19 (.75)	9.8 (.39)	63.4 (2.50)	35.3 (1.39)
	3/8	10 267 1238	19 (.75)	11.2 (.44)	63.4 (2.50)	37.0 (1.46)
14	3/8	10 267 1438	19 (.75)	11.2 (.44)	61.4 (2.42)	36.0 (1.42)
	1/2	10 267 1448	24 (.94)	14.7 (.58)	63.4 (2.50)	39.2 (1.54)

Pneufit C ISO G Swivel Male Branch Tee

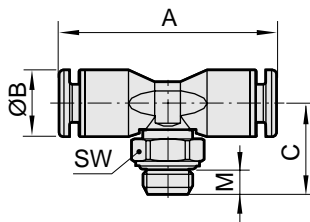

O.D. Tube	BSP Thread	Part Number	A	B	C	SW	M
4	1/8"	C02670418	36.0	10.7	20	11.0	5.5
6	1/8"	C02670618	42.0	12.9	20.5	11.0	5.5
6	1/4"	C02670628	42.0	12.9	23.5	11.0	8.0
8	1/4"	C02670828	50.0	14.5	25.5	17.0	8.0
8	3/8"	C02670838	50.0	14.5	26.5	17.0	8.0
10	3/8"	C02671038	55.0	17.4	28.5	17.0	9.0



Pneufit ISO R Swivel Male Branch Tee

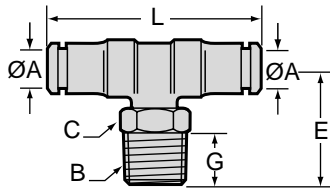

CAUTION: Swivel adapters are not suitable for use in continuously rotating or gyrating applications.

A Tube O.D.	B ISO R Thread	Part Number	C A/F	G	L	E
4	1/8	10 167 0418	10 (.39)	7.7 (.30)	33.8 (1.33)	21.4 (.81)
	1/4	10 167 0428	14 (.55)	11.1 (.44)	33.8 (1.33)	24.1 (.95)
5	1/8	10 167 0518	11 (.43)	7.7 (.30)	36.8 (1.45)	21.0 (.83)
	1/4	10 167 0528	14 (.55)	11.1 (.44)	36.8 (1.45)	24.6 (.97)
6	1/8	10 167 0618	11 (.43)	7.7 (.30)	39.2 (1.54)	21.5 (.85)
	1/4	10 167 0628	14 (.55)	11.1 (.44)	39.2 (1.54)	25.1 (.99)
8	1/8	10 167 0818	14 (.55)	7.7 (.30)	42.6 (1.68)	23.0 (.91)
	1/4	10 167 0828	14 (.55)	11.1 (.44)	42.6 (1.68)	26.1 (1.03)
	3/8	10 167 0838	17 (.67)	12.7 (.50)	43.6 (1.72)	30.5 (1.20)
10	1/4	10 167 1028	17 (.67)	11.1 (.44)	53.4 (2.10)	28.8 (1.13)
	3/8	10 167 1038	17 (.67)	12.7 (.50)	53.4 (2.10)	30.5 (1.20)
12	1/4	10 167 1228	19 (.75)	11.1 (.44)	63.4 (2.50)	31.8 (1.25)
	3/8	10 167 1238	22 (.87)	12.7 (.50)	63.4 (2.50)	34.2 (1.35)
	1/2	10 167 1248	22 (.87)	15.9 (.63)	63.4 (2.50)	38.2 (1.50)
14	3/8	10 167 1438	22 (.87)	12.7 (.50)	61.4 (2.42)	33.2 (1.31)
	1/2	10 167 1448	22 (.87)	15.9 (.63)	63.4 (2.50)	37.0 (1.46)

Pneufit C ISO R Swivel Male Branch Tee

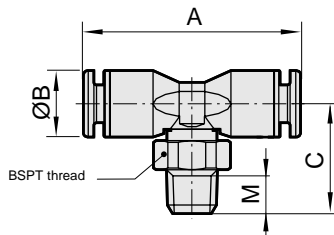

O.D. Tube	BSPP Thread	Part Number	A	B	C	M
4	1/8"	C01670418	36.0	10.7	19.5	8.6
4	1/4"	C01670428	26.0	10.7	20.5	11.1
6	1/8"	C01670618	42.0	12.9	21.5	8.6
6	1/4"	C01670628	42.0	12.9	24.0	11.1
6	3/8"	C01670638	42.0	12.9	26.0	12.7
8	1/4"	C01670828	50.0	14.5	25.0	11.1
8	3/8"	C01670838	50.0	14.5	26.5	12.7
10	3/8"	C01671038	55.0	17.4	28.5	12.7



Metric Series Push-In Fittings

Dimensions in mm (inches)

Pneufit ISO G Swivel Male Run Tee

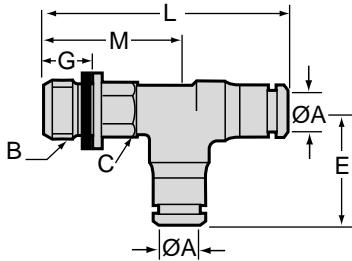

CAUTION: Swivel adapters are not suitable for use in continuously rotating or gyrating applications.

A Tube O.D.	B ISO G or Metric Thrd	Part Number	C				
			A/F	G	L	M	E
4	M5 x .8	10 268 0405	8 (.31)	5.0 (.20)	36.5 (1.44)	19.5 (.77)	17.0 (.67)
	1/8	10 268 0418	11 (.43)	7.2 (.28)	38.7 (1.52)	21.8 (.86)	16.9 (.67)
5	1/8	10 268 0518	11 (.43)	7.2 (.28)	40.7 (1.60)	22.3 (.88)	18.4 (.72)
	1/4	10 268 0528	11 (.43)	9.8 (.39)	44.4 (1.75)	26.0 (1.02)	18.4 (.72)
6	1/8	10 268 0618	11 (.43)	7.2 (.28)	42.4 (1.67)	22.8 (.90)	19.6 (.77)
	1/4	10 268 0628	11 (.43)	9.8 (.39)	46.1 (1.81)	26.5 (1.04)	19.6 (.77)
8	1/8	10 268 0818	13 (.51)	7.2 (.28)	45.1 (1.78)	23.8 (.94)	21.3 (.84)
	1/4	10 268 0828	17 (.67)	9.8 (.39)	50.4 (1.98)	29.1 (1.15)	21.3 (.84)
10	1/4	10 268 1028	17 (.67)	9.8 (.39)	58.3 (2.30)	31.6 (1.24)	26.7 (1.05)
	3/8	10 268 1038	19 (.75)	11.2 (.44)	60.0 (2.36)	33.3 (1.31)	26.7 (1.05)
12	1/4	10 268 1228	19 (.75)	9.8 (.39)	67.0 (2.64)	35.3 (1.39)	31.7 (1.25)
	3/8	10 268 1238	19 (.75)	11.2 (.44)	68.7 (2.70)	37.0 (1.46)	31.7 (1.25)
14	3/8	10 268 1438	19 (.75)	11.2 (.44)	69.2 (2.72)	36.0 (1.42)	33.2 (1.31)
	1/2	10 268 1448	24 (.94)	14.7 (.58)	72.5 (2.85)	39.2 (1.54)	33.2 (1.31)

Pneufit ISO G Swivel Male Run Tee

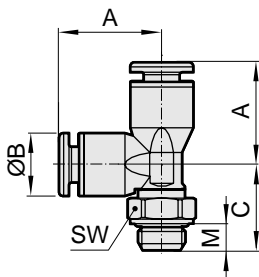

O.D. Tube	BSPP Thread	Part Number	A	B	C	SW	M
3	M3	C02680303	18.0	10.7	15.0	8.0	3.5
4	1/8"	C02680418	18.0	10.7	20.0	11.0	5.5
6	1/8"	C02680618	21.0	12.9	20.5	11.0	5.5
6	1/4"	C02680628	21.0	12.9	23.5	11.0	8.0
8	1/4"	C02680828	25.0	14.5	25.5	17.0	8.0
8	3/8"	C02680838	25.0	14.5	26.5	17.0	9.0
10	3/8"	C02681038	27.5	17.4	28.5	17.0	9.0



Pneufit C Parallel Y Adaptor

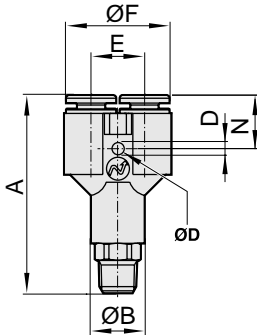

O.D. Tube	O.D. Tube	ISO R Thread	Part Number	A	B	D	E	F	N
4	4	1/8"	C01880418	48.0	11.0	3.2	11.0	22.0	13.0
6	6	1/8"	C01880618	52.0	14.0	3.2	14.0	28.0	14.25
6	6	1/4"	C01880628	55.0	14.0	3.2	14.0	28.0	14.25
8	8	1/8"	C01880818	55.0	15.0	3.2	16.0	31.0	14.9
8	8	1/4"	C01880828	57.5	15.0	3.2	16.0	31.0	14.9
10	10	3/8"	C01881038"	70.5	20.0	4.2	20.6	42.0	14.9
10	10	1/2"	C01881048	74.0	20.0	4.2	20.6	42.0	14.9

Pneufit C Parallel Y Adaptor

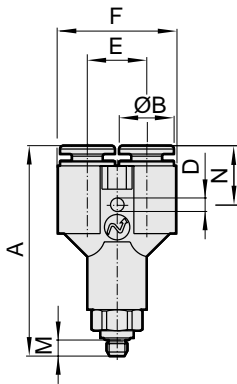

O.D. Tube	Thread	Part Number	A	B	D	E	F	N	M
4	M5	C02880405	46.5	11.0	3.2	11.0	22.0	13.0	4.3
6	M5	C02880605	50.0	14.0	3.2	14.0	28.0	14.25	4.3



Metric Series Push-In Fittings

Dimensions in mm (inches)

Pneufit ISO R Swivel Male Run Tee

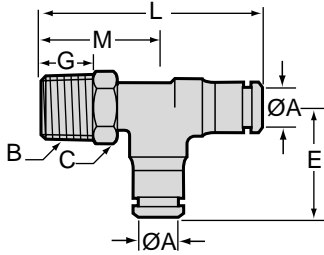

CAUTION: Swivel adapters are not suitable for use in continuously rotating or gyrating applications.

A Tube O.D.	B ISO R Thread	Part Number	C A/F	G	L	M	E
4	1/8	10 168 0418	10 (.39)	7.7 (.30)	37.4 (1.47)	20.5 (.81)	16.9 (.67)
	1/4	10 168 0428	14 (.55)	11.1 (.44)	41.0 (1.61)	24.1 (.95)	16.9 (.67)
5	1/8	10 168 0518	11 (.43)	7.7 (.30)	39.4 (1.55)	21.0 (.83)	18.4 (.72)
	1/4	10 168 0528	14 (.55)	11.1 (.44)	43.0 (1.69)	24.6 (.97)	18.4 (.72)
6	1/8	10 168 0618	11 (.43)	7.7 (.30)	41.1 (1.61)	21.5 (.85)	19.6 (.77)
	1/4	10 168 0628	14 (.55)	11.1 (.44)	44.7 (1.76)	25.1 (.99)	19.6 (.77)
8	1/8	10 168 0818	14 (.55)	7.7 (.30)	44.3 (1.74)	23.0 (.91)	21.3 (.84)
	1/4	10 168 0828	14 (.55)	11.1 (.44)	47.4 (1.87)	26.1 (1.03)	21.3 (.84)
	3/8	10 168 0838	17 (.67)	12.7 (.50)	52.3 (2.06)	30.5 (1.20)	21.8 (.86)
10	1/4	10 168 1028	17 (.67)	11.1 (.44)	55.5 (2.19)	28.8 (1.13)	26.7 (1.05)
	3/8	10 168 1038	17 (.67)	12.7 (.50)	57.2 (2.25)	30.5 (1.20)	26.7 (1.05)
12	1/4	10 168 1228	19 (.75)	11.1 (.44)	63.5 (2.50)	31.8 (1.25)	31.7 (1.25)
	3/8	10 168 1238	22 (.87)	12.7 (.50)	65.9 (2.59)	34.2 (1.35)	31.7 (1.25)
	1/2	10 168 1248	22 (.87)	15.9 (.63)	69.9 (2.75)	38.2 (1.50)	31.7 (1.25)
14	3/8	10 168 1438	22 (.87)	12.7 (.50)	66.5 (2.62)	33.2 (1.31)	33.2 (1.31)
	1/2	10 168 1448	22 (.87)	15.9 (.63)	70.2 (2.76)	37.0 (1.46)	33.2 (1.31)

Pneufit C ISO R Swivel Male Run Tee

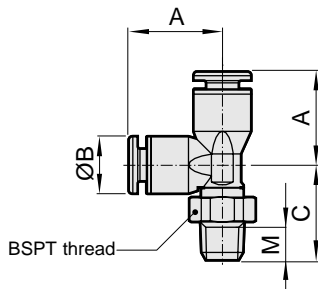

O.D. Tube	ISO R Thread	Part Number	A	B	C	M
4	1/8"	C01680418	18.0	10.7	19.5	8.6
4	1/4"	C01680428	18.0	10.7	20.5	11.1
6	1/8"	C01680618	21.0	12.9	21.0	8.6
6	1/4"	C01680628	21.0	12.9	24.0	11.1
6	3/8"	C01680638	21.0	12.9	26.0	12.7
8	1/4"	C01680828	25.0	14.5	25.0	11.1
8	3/8"	C01680838	25.0	14.5	26.5	12.7
10	3/8"	C01681038	27.5	17.4	28.5	12.7



Pneufit ISO G Swivel 45° Male Elbow

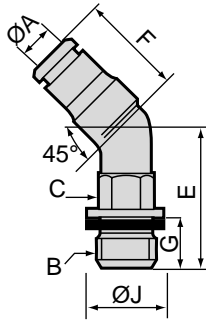

A Tube O.D.	B ISO G Thread	Part Number	C A/F	E	F	G	J
6	1/8	10 257 0618	11.0 (.43)	19.3 (.76)	17.7 (.70)	7.2 (.28)	13.8 (.54)
	1/4	10 257 0628	11.0 (.43)	23.0 (.91)	17.7 (.70)	9.8 (.39)	17.8 (.70)
8	1/8	10 257 0818	11.0 (.43)	20.6 (.81)	19.5 (.77)	7.2 (.28)	13.8 (.54)
	1/4	10 257 0828	17.0 (.67)	25.9 (1.02)	19.5 (.77)	9.8 (.39)	17.8 (.70)

Pneufit ISO G Banjo Elbow

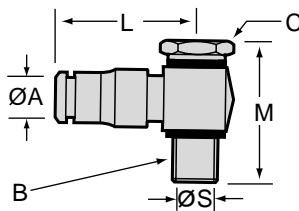

A Tube O.D.	B ISO G or Metric Thread	Part Number	C A/F	M	L	S
4	M5 x .8	10 A51 0405	8 (.31)	22 (.87)	18.7 (.37)	2.5 (.10)
	1/8	10 A51 0418	14 (.55)	30 (1.18)	20.6 (.81)	5.0 (.20)
5	M5 x .8	10 A51 0505	8 (.31)	22 (.87)	20.2 (.80)	2.5 (.10)
	1/8	10 A51 0518	14 (.55)	30 (1.18)	21.7 (.85)	5.0 (.20)
6	M5 x .8	10 A51 0605	8 (.31)	22 (.87)	22.2 (.87)	2.5 (.10)
	1/8	10 A51 0618	14 (.55)	30 (1.18)	23.7 (.93)	5.0 (.20)
	1/4	10 A51 0628	17 (.67)	34 (1.34)	24.2 (.95)	8.5 (.33)
8	1/8	10 A51 0818	14 (.55)	30 (1.18)	23.7 (.93)	5.0 (.20)
	1/4	10 A51 0828	17 (.67)	34 (1.34)	24.7 (.95)	8.5 (.33)
	3/8	10 A51 0838	22 (.87)	41 (1.61)	26.7 (1.05)	10.0 (.39)
10	1/4	10 A51 1028	17 (.67)	34 (1.34)	30.2 (1.19)	8.5 (.33)
	3/8	10 A51 1038	22 (.87)	41 (1.61)	31.2 (1.23)	10.0 (.39)



Metric Series Push-In Fittings

Dimensions in mm (inches)

Pneufit Single Stacking Banjo Bolt

(Supplied complete w/sealing washers)

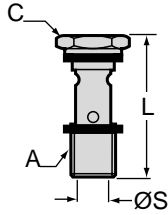

A ISO G or Metric Thread	Part Number	C A/F	L	S
M5 x .8	20 A00 0005	8 (.31)	22.0 (.87)	2.5 (.10)
1/8	20 A00 0018	14 (.55)	30.0 (1.18)	5.0 (.20)
1/4	20 A00 0028	17 (.67)	34.0 (1.34)	8.5 (.33)
3/8	20 A00 0038	22 (.87)	41.0 (1.61)	10.0 (.39)
1/2	20 A00 0048	27 (1.06)	47.5 (1.87)	11.5 (.45)

Pneufit Double Stacking Banjo Bolt

(Supplied complete w/sealing washers)

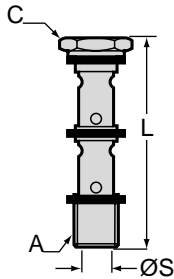

A ISO G or Metric Thread	Part Number	C A/F	L	S
M5 x .8	20 B00 0005	8 (.31)	34.5 (1.36)	2.5 (.10)
1/8	20 B00 0018	14 (.55)	46.5 (1.83)	5.0 (.20)
1/4	20 B00 0028	17 (.67)	52.5 (2.07)	8.5 (.33)
3/8	20 B00 0038	22 (.87)	64.0 (2.52)	10.0 (.39)
1/2	20 B00 0048	27 (1.06)	72.5 (2.85)	11.5 (.45)

Pneufit Triple Stacking Banjo Bolt

(Supplied complete w/sealing washers)

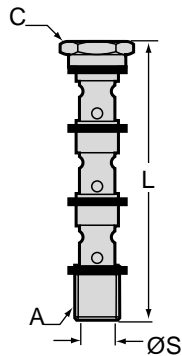

A ISO G Thread	Part Number	C A/F	L	S
1/8	20 C00 0018	14 (.55)	63.0 (2.48)	5.0 (.20)
1/4	20 C00 0028	17 (.67)	71.5 (2.81)	8.5 (.33)
3/8	20 C00 0038	22 (.87)	87.0 (3.43)	10.0 (.39)



Pneufit Single Stacking Banjo Bolt w/ Top Port (ISO G)

(Supplied complete w/sealing washers)

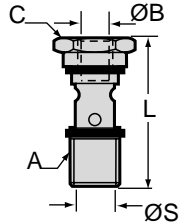

A ISO G or Metric Thread	B ISO G or Metric Top Port Thread	Part Number	C A/F	L	S
M5 x .8	M5 x .8	20 D00 0505	8 (.31)	25.6 (1.01)	2.5 (.10)
1/4	M5 x .8	20 D00 0528	17 (.67)	34.0 (1.34)	8.5 (.33)
	1/8	20 E00 1828	17 (.67)	35.5 (1.40)	6.0 (.24)
	1/4	20 F00 2828	17 (.67)	45.0 (1.77)	8.5 (.33)
1/8	1/8	20 E00 1818	14 (.55)	36.0 (1.42)	5.0 (.20)
3/8	M5 x .8	20 D00 0538	22 (.87)	41.0 (1.61)	10.0 (.39)
	1/8	20 E00 1838	22 (.87)	41.0 (1.61)	10.0 (.39)
	3/8	20 G00 3838	22 (.87)	52.0 (2.05)	10.0 (.39)

Pneufit Elbow Body

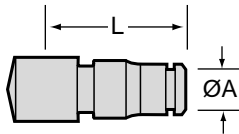

A Tube O.D.	Use With Banjo Bolt Size	Part Number	L
4	M5 x .8	10 051 0405	18.7 (.74)
	1/8	10 051 0418	20.6 (.81)
5	M5 x .8	10 051 0505	20.2 (.80)
	1/8	10 051 0518	21.7 (.85)
6	M5 x .8	10 051 0605	22.2 (.87)
	1/8	10 051 0618	23.7 (.93)
	1/4	10 051 0628	24.2 (.95)
8	1/8	10 051 0818	23.7 (.93)
	1/4	10 051 0828	24.7 (.97)
	3/8	10 051 0838	26.7 (1.05)
10	1/4	10 051 1028	30.2 (1.19)
	3/8	10 051 1038	31.2 (1.23)
12	3/8	10 051 1238	33.2 (1.31)
	1/2	10 051 1248	38.2 (1.50)

Pneufit Tee Body

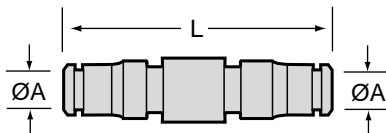

A Tube O.D.	Use With Banjo Bolt Size	Part Number	L
4	M5 x .8	10 071 0405	37.4 (1.47)
	1/8	10 071 0418	41.2 (1.62)
5	M5 x .8	10 071 0505	40.4 (1.59)
	1/8	10 071 0518	43.3 (1.70)
6	1/8	10 071 0618	47.4 (1.87)
	1/4	10 071 0628	48.4 (1.91)
8	1/8	10 071 0818	47.4 (1.87)
	1/4	10 071 0828	49.4 (1.94)



Metric Series Push-In Fittings

Dimensions in mm (inches)

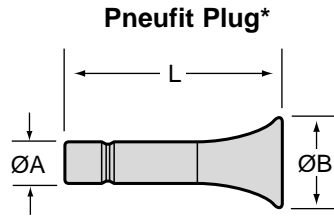

*Material: Thermoplastic

A Stem O.D.	Part Number	L	B
4	11 004 0400	26.5 (1.04)	9.6 (.38)
5	11 004 0500	28.0 (1.10)	10.6 (.42)
6	11 004 0600	28.5 (1.12)	11.6 (.46)
8	11 004 0800	29.5 (1.16)	12.7 (.50)
10	11 004 1000	34.0 (1.34)	15.6 (.61)
12	11 004 1200	37.5 (1.48)	16.7 (.66)
14	11 004 1400	37.5 (1.48)	19.6 (.77)

Pneufit Pressure Indicator

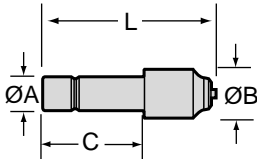

A Stem O.D.	Part Number	B	C	L
4	10 010 0400	8.0 (.31)	16.6 (.65)	28.5 (1.12)
6	10 010 0600	8.0 (.31)	18.5 (.73)	30.5 (1.20)
8	10 010 0800	10.0 (.39)	19.5 (.77)	31.5 (1.24)

Note: The red indicator button remains out at all times unless depressed. If it stays in when pressed it indicates less than 1 bar (14.5 psi) is present.

Pneufit Barb Adapter

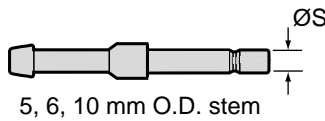

5, 6, 10 mm O.D. stem

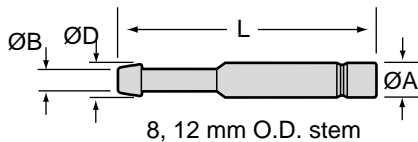

8, 12 mm O.D. stem

A Stem O.D.	Part Number	B Hose Bore	L	D (ref)	S I.D.
4	10 019 0403	3 (.12)	34.0 (1.34)	4.50 (.18)	1.8 (.07)
	10 019 0405	5 (.20)	34.0 (1.34)	6.50 (.26)	2.1 (.08)
5	10 019 0505	5 (.20)	35.6 (1.40)	6.50 (.26)	2.8 (.11)
6	10 019 0605	5 (.20)	36.0 (1.42)	6.50 (.26)	2.8 (.11)
8	10 019 0806	6.3 (.25)	37.0 (1.46)	8.02 (.32)	4.3 (.17)
	10 019 0808	8 (.31)	38.5 (1.52)	9.75 (.38)	5.5 (.22)
10	10 019 1006	6.3 (.25)	41.5 (1.63)	8.02 (.32)	4.3 (.17)
	10 019 1008	8 (.31)	43.0 (1.69)	9.75 (.38)	5.5 (.22)
	10 019 1010	10 (.39)	44.0 (1.73)	12.15 (.48)	7.3 (.29)
12	10 019 1208	8 (.31)	46.5 (1.83)	9.75 (.38)	5.5 (.22)
	10 019 1210	10 (.39)	46.5 (1.83)	12.15 (.48)	7.3 (.29)
	10 019 1212	12.5 (.49)	47.3 (1.86)	15.40 (.61)	9.7 (.38)
14	10 019 1412	12.5 (.49)	47.2 (1.86)	15.40 (.61)	9.7 (.38)



ISO Pipe Fittings are used to connect pneumatic products containing ISO or equivalent port forms.

Specifications

Fluids: Compressed air, nitrogen and inert and non-combustible gasses, and fluids comparable with materials of construction.

Working Pressure:

750 mm Hg to 18 bar (29.5" Hg vacuum to 260 psig.)

Working Temperature: -20°F to 80°F (0° to 175°F)

Materials of Construction

Body: Nickel plated Brass

Sealing Washers (ISO G): Copper

Pneufit ISO G Hex Nipple
(Supplied with sealing washers)

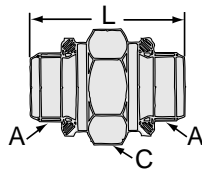

A ISO G Thread	Part Number	C A/F	L
1/8	16 020 1818	14 (.55)	23.5 (.93)
1/4	16 020 2828	19 (.75)	30.6 (1.20)
3/8	16 020 3838	22 (.87)	35.7 (1.41)
1/2	16 020 4848	27 (1.06)	44.6 (1.76)

Pneufit ISO R Hex Nipple

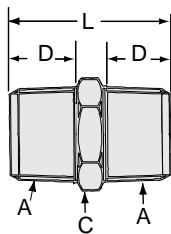

A ISO R Thread	Part Number	C A/F	L
1/8	15 020 1818	10 (.39)	24.0 (.94)
1/4	15 020 2828	14 (.55)	27.6 (1.09)
3/8	15 020 3838	17 (.67)	31.7 (1.25)
1/2	15 020 4848	22 (.87)	38.4 (1.51)

NOTE: Threads are not provided with pre-applied thread sealant.



Metric Series Push-In Fittings

Dimensions in mm (inches)

Manifold*

O/D tube

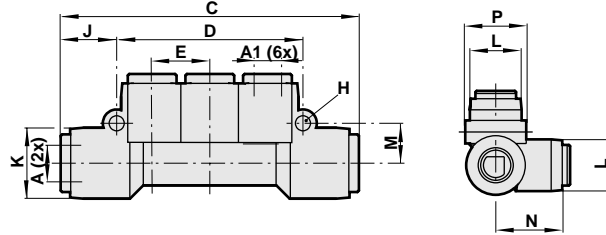

Product Number	A tube O.D.	A1 tube O.D.	C	D	E	H	J	K	L	M	N	P
12 OD6 0502	8.0 (0.3)	4.0 (0.2)	68.0 (2.7)	42.0 (1.7)	13.0 (0.5)	3.4 (0.1)	12.7 (0.5)	16.0 (0.6)	14.0 (0.6)	9.0 (0.4)	20.0 (0.8)	16.4 (0.6)
10 OD6 0806	8.0 (0.3)	6.0 (0.2)	68.0 (2.7)	42.0 (1.7)	13.0 (0.5)	3.4 (0.1)	12.7 (0.5)	16.0 (0.6)	14.0 (0.6)	9.0 (0.4)	20.2 (0.8)	16.4 (0.6)
10 OD6 1006	10.0 (0.4)	6.0 (0.2)	83.0 (3.3)	48.0 (1.9)	15.0 (0.6)	3.4 (0.1)	17.2 (0.7)	20.0 (0.8)	16.0 (0.6)	10.5 (0.4)	22.7 (0.9)	20.4 (0.8)
10 OD6 1008	10.0 (0.4)	8.0 (0.3)	83.0 (3.3)	48.0 (1.9)	15.0 (0.6)	3.4 (0.1)	17.2 (0.7)	20.0 (0.8)	16.0 (0.6)	10.5 (0.4)	22.7 (0.9)	20.4 (0.8)

* Body material thermoplastic

Manifold*

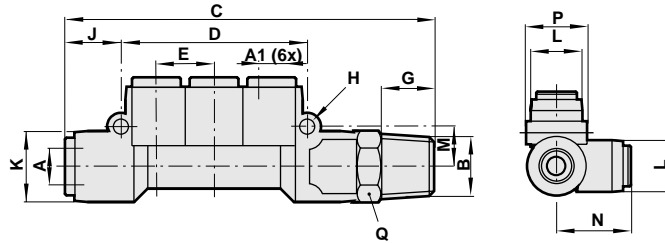

Product Number	A tube O.D.	A1 tube O.D.	B ISO R thread	C	D	E	G	H	J	K	L	M	N	P	Q A/F
10 1D6 0428	8.0 (0.3)	4.0 (0.2)	1/4	83.0 (3.3)	42.0 (1.7)	13.0 (0.5)	11.1 (0.4)	3.4 (0.1)	12.7 (0.5)	16.0 (0.6)	14.0 (0.6)	9.0 (0.4)	20.2 (0.8)	16.4 (0.6)	17.0 (0.7)
10 1D6 0438	8.0 (0.3)	4.0 (0.2)	3/8	85.0 (3.3)	42.0 (1.7)	13.0 (0.5)	12.7 (0.5)	3.4 (0.1)	12.7 (0.5)	16.0 (0.6)	14.0 (0.6)	9.0 (0.4)	20.2 (0.8)	16.4 (0.6)	19.0 (0.7)
10 1D6 0628	8.0 (0.3)	6.0 (0.2)	1/4	83.0 (3.3)	42.0 (1.7)	13.0 (0.5)	11.1 (0.4)	3.4 (0.1)	12.7 (0.5)	16.0 (0.6)	14.0 (0.6)	9.0 (0.4)	20.2 (0.8)	16.4 (0.6)	19.0 (0.7)
10 1D6 0638	8.0 (0.3)	6.0 (0.2)	3/8	85.0 (3.3)	42.0 (1.7)	13.0 (0.5)	12.7 (0.5)	3.4 (0.1)	12.7 (0.5)	16.0 (0.6)	14.0 (0.6)	9.0 (0.4)	20.2 (0.8)	16.4 (0.6)	19.0 (0.7)
10 1D6 0838	10.0 (0.4)	8.0 (0.3)	3/8	100.0 (3.9)	48.0 (1.9)	15.0 (0.6)	12.7 (0.5)	3.4 (0.1)	17.2 (0.7)	20.0 (0.8)	16.0 (0.6)	10.5 (0.4)	22.7 (0.9)	20.4 (0.8)	19.0 (0.7)
10 1D6 0848	10.0 (0.4)	8.0 (0.3)	1/2	104.0 (4.1)	48.0 (1.9)	15.0 (0.6)	15.9 (0.6)	3.4 (0.1)	17.2 (0.7)	20.0 (0.8)	16.0 (0.6)	10.5 (0.4)	22.7 (0.9)	20.4 (0.8)	22.0 (0.9)

* Body material thermoplastic

Function Fittings, Flow Controls, and Accessory Valves



12 VA0 Right Angle (Banjo) Flow Control (inch-knob adj.)	..FIT-3-3
12 VB0 Right Angle (Banjo) Flow Control (inch-slot adj.)	..FIT-3-3
10 TA0 Right Angle (Banjo) Flow Control (metric-knob adj.)	FIT-3-4
10 K51 Right Angle (Banjo) Flow Control (metric-slot adj.)	..FIT-3-4
T1000 In-line Flow Control (NPT and ISO G)FIT-3-6
T15 Push-In Flow RegulatorsFIT-3-8
M/800, C/800 Heavy Duty In-Line Flow ControlFIT-3-10
M/600, C/600 Heavy Duty In-Line Flow ControlFIT-3-12
M/650, C/650, M/677, C/677 Precision Flow ControlsFIT-3-14
T51/T52/T53 Series, PIF Non Return ValvesFIT-3-16
T55, T56 Non-Return ValvesFIT-3-16
T60 Air Fuse (Excess Flow Check) (NPT and ISO G)FIT-3-18
Pressure Reducing Fitting (inch and metric)FIT-3-23
Pilot Operated Check Valve (inch and metric)FIT-3-26
Pressure Sensor Fitting (inch and metric)FIT-3-28
T70 Quick Exhaust Valves (NPT and ISO G)FIT-3-30
T65 1/8" and 1/4" Shuttle Valves (NPT and ISO G)FIT-3-32

- 360° rotation of the banjo body around the bolt allows for ideal positioning of tubing.
- Low profile and reduced physical size provide space saving installations, while internal configuration provides the flow capacity of much bulkier designs.
- Tapered adjustment needles with large adjustment ranges provide linear flows and greater precision.
- Knurled adjustment knobs (w/screw driver slot) and lock nuts on 12 VA0 and 10 TA0 series provide finger tip adjustment. Tamper resistance on the 12 VBO and 10 K51 is provided by a slotted adjustment screw covered by a protective plastic cap.
- Direct mounting of flow controls on pneumatic actuators minimizes the adjustment problems encountered due to the compressibility of air in long tubing runs between the actuator and control valving. Additionally, direct mounted flow controls end the confusion over which actuator in a circuit is being controlled.
- Metallic components are limited to nickel plated all brass construction, eliminating the potential problems encountered with products constructed of dissimilar metals.
- Adjustment needles and banjo bodies are retained, preventing accidental loss of the needle or lock nut.



Operation:

Flow Controls are checked adjustable controls of the meter out type. Compressed air passes freely into the push-in fitting portion of the flow control, flowing past the check seal and entering the connected component. In reverse flow conditions, air passes back into the flow control and energizes the check seal. Air must now flow through the metered passage controlled by the tapered adjustment needle of the flow control, and finally exits through the push-in fitting end.

Specifications

Fluid: Compressed air.

Note: For other types of fluids or compressed gases, please consult factory.

Working Pressure: 5 to 150 psig (.3 to 10 bar)

Temperature Range: 0° to 175°F (-20° to 80°C)

Materials of Construction:

Banjo bolt, collet, adjustment knob and lock nut: Nickel plated brass

Tapered adjusting needle: Brass

Banjo Body, 12 VA0 XXXX and 10 TA0: Thermoplastic

12 VBO and 10 K51 XXXX: Nickel plated brass

O-rings and check-seal: Silicone free Nitrile

Sealing washer: Thermoplastic (ISO G and 10-32 UNF)

Tubing: Nylon 11 or 12, 95 durometer polyurethane.

Thread Sealant: Thread sealant is applied to the full circumference of tapered male threads.

Options

Special versions of the flow controls are available, including meter-in (12 WA0 Series) and bi-directional control configurations. Please consult factory with specific quantities and requirements.

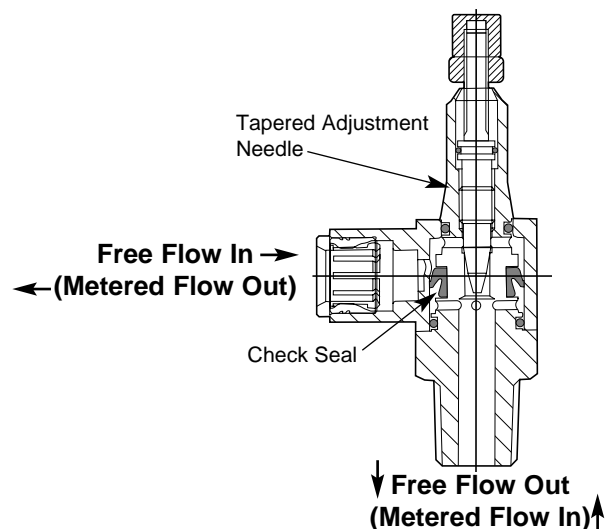

Pneumatic Symbol

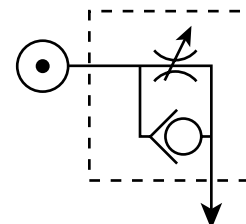



VA0 Series

Dimensions in Inches (mm)

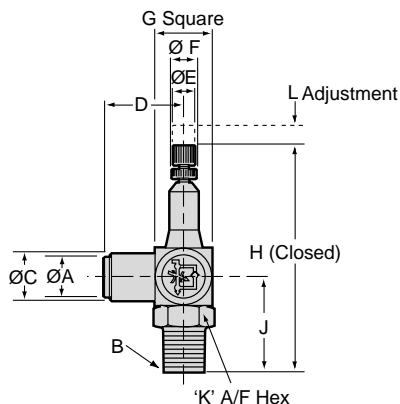

A Tube O.D.	B NPT or UNF Thread	Part Number	C	D	E	F	G	H	J	K A/F	L Adj
5/32"	10-32 UNF	12 VA0 0210	0.37 (9.5)	1.04 (26.5)	0.16 (4.0)	0.74 (18.7)	0.38 (9.5)	1.51 (38.4)	0.45 (11.4)	-	0.12 (3.0)
	1/8	12 VA0 0218	0.45 (11.5)	0.87 (22.0)	0.31 (8.0)	0.35 (9.0)	0.63 (16.0)	2.09 (53.0)	0.89 (22.5)	9/16"	0.12 (3.0)
1/4"	1/8	12 VA0 0418	0.51 (13.0)	0.91 (23.0)	0.31 (8.0)	0.35 (9.0)	0.63 (16.0)	2.09 (53.0)	0.89 (22.5)	9/16"	0.12 (3.0)
	1/4	12 VA0 0428	0.53 (13.5)	1.00 (25.5)	0.39 (10.0)	0.43 (11.0)	0.79 (20.0)	2.64 (67.0)	1.16 (29.5)	11/16"	0.24 (6.0)
3/8"	1/4	12 VA0 0628	0.77 (19.5)	1.24 (31.5)	0.39 (10.0)	0.43 (11.0)	0.79 (20.0)	2.64 (67.0)	1.16 (29.5)	11/16"	0.24 (6.0)
	3/8	12 VA0 0638	0.77 (19.5)	1.28 (32.5)	0.47 (12.0)	0.51 (13.0)	0.87 (22.0)	3.07 (78.0)	1.30 (33.0)	3/4"	0.24 (6.0)
1/2"	1/2"	12 VA0 0748	0.91 (23.0)	1.50 (38.0)	0.63 (16.0)	0.71 (18.0)	1.06 (27.0)	3.66 (93.0)	1.65 (42.0)	7/8"	0.28 (7.0)

VB0 Series

Dimensions in Inches (mm)

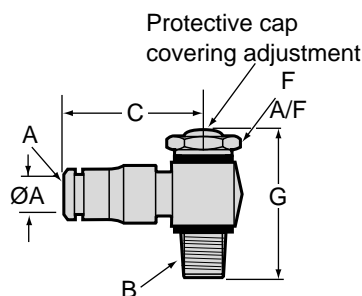

A Tube O.D.	B NPT or UNF Thread	Part Number	C	F A/F	G
5/32"	10-32 UNF	12 VB0 0210	0.74 (19)	-	1.06 (27)
	1/8	12 VB0 0218	0.88 (22)	9/16"	1.57 (40)
1/4"	1/8	12 VB0 0418	0.91 (23)	9/16"	1.57 (40)
	1/4	12 VB0 0428	0.99 (25)	3/4"	1.83 (46)
3/8"	1/4	12 VB0 0628	1.23 (31)	3/4"	1.83 (46)
	3/8	12 VB0 0638	1.29 (33)	7/8"	2.22 (56)
1/2"	3/8	12 VB0 0738	1.46 (37)	7/8"	2.22 (56)
	1/2	12 VB0 0748	1.56 (40)	11/16"	2.55 (65)

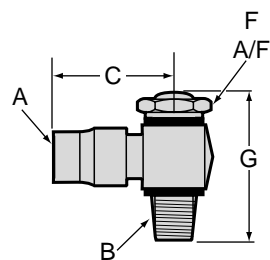

A NPT Female	B NPT Male	Part Number	C	F	G
1/8	1/8	12 VB0 1818	0.83 (21)	9/16"	1.57 (40)
1/4	1/4	12 VB0 2828	1.14 (29)	3/4"	1.83 (46)
3/8	3/8	12 VB0 3838	1.24 (31)	7/8"	2.22 (56)
1/2	1/2	12 VB0 4848	1.53 (39)	11/16"	2.55 (65)



Function Fittings and Flow Controls

TA0 Series

Dimensions in MM (inches)

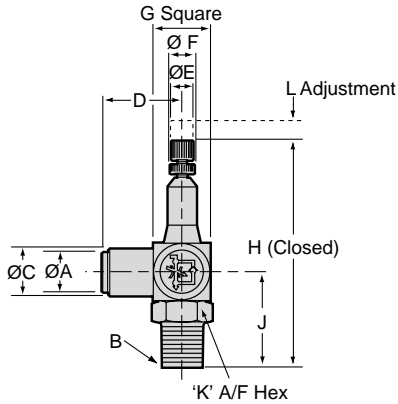

A Tube O.D.	B ISO R Thread	Part Number	C	D	E	F	G	H	J	K A/F	L Adj
4	1/8	10 TA0 0418	11.5 (.45)	22.0 (.87)	8.0 (.31)	9.0 (.35)	16 (.63)	53 (2.09)	22.5 (.89)	14 (.55)	3 (.12)
	1/8	10 TA0 0618	13.0 (.51)	23.0 (.91)	8.0 (.31)	9.0 (.35)	16 (.63)	53 (2.09)	22.5 (.89)	14 (.55)	3 (.12)
6	1/4	10 TA0 0628	13.5 (.53)	25.5 (1.00)	10.0 (.39)	11.0 (.43)	20 (.79)	67 (2.64)	29.5 (1.16)	17 (.67)	6 (.24)
	1/4	10 TA0 0828	15.5 (.61)	27.0 (1.06)	10.0 (.39)	11.0 (.43)	20 (.79)	67 (2.64)	29.5 (1.16)	17 (.67)	6 (.24)
8	3/8	10 TA0 0838	15.5 (.61)	28.0 (1.10)	12.0 (.47)	13.0 (.51)	22 (.87)	78 (3.07)	33.0 (1.30)	19 (.75)	6 (.24)
	1/4	10 TA0 1028	19.5 (.77)	31.5 (1.24)	10.0 (.39)	11.0 (.43)	20 (.79)	67 (2.64)	29.5 (1.16)	17 (.67)	6 (.24)
10	3/8	10 TA0 1038	19.5 (.77)	32.5 (1.28)	12.0 (.47)	13.0 (.51)	22 (.87)	78 (3.07)	33.0 (1.30)	19 (.75)	6 (.24)

K51 Series

Dimensions in Inches (mm)

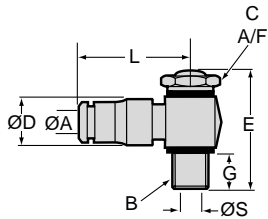

A Tube O.D.	B ISO G or Metric Thread	Part Number	C A/F	D	E	G	L	S
4	M5 X .8	10 K51 0405	8 (.31)	9.5 (.37)	26.5 (1.04)	4.0 (.16)	18.7 (.74)	2.5 (.10)
	1/8	10 K51 0418	14 (.55)	11.0 (.43)	34.0 (1.34)	6.5 (.26)	20.6 (.81)	5.0 (.20)
5	M5 X .8	10 K51 0505	8 (.31)	11.0 (.43)	26.5 (1.04)	4.0 (.16)	20.2 (.80)	2.5 (.10)
	1/8	10 K51 0518	14 (.55)	11.5 (.45)	34.0 (1.34)	6.5 (.26)	21.7 (.85)	5.0 (.20)
6	M5 X .8	10 K51 0605	8 (.31)	12.5 (.49)	26.5 (1.04)	4.0 (.16)	22.2 (.87)	2.5 (.10)
	1/8	10 K51 0618	14 (.55)	12.5 (.49)	34.0 (1.34)	6.5 (.26)	23.7 (.93)	5.0 (.20)
	1/4	10 K51 0628	17 (.67)	13.0 (.51)	36.5 (1.44)	7.0 (.28)	24.2 (.95)	8.5 (.33)
8	1/8	10 K51 0818	14 (.55)	13.5 (.53)	34.0 (1.34)	6.0 (.26)	23.7 (.93)	-
	1/4	10 K51 0828	17 (.67)	14.0 (.55)	36.5 (1.44)	7.0 (.28)	24.7 (.97)	8.5 (.33)
	3/8	10 K51 0838	22 (.87)	16.5 (.65)	51.5 (2.03)	10.0 (.39)	26.7 (1.05)	10.0 (.39)
10	3/8	10 K51 1038	22 (.87)	17.0 (.67)	51.5 (2.03)	10.0 (.39)	31.2 (1.23)	10.0 (.39)
12	1/2	10 K51 1248	27 (1.06)	17.5 (.69)	57.5 (2.26)	10.0 (.39)	38.2 (1.50)	-

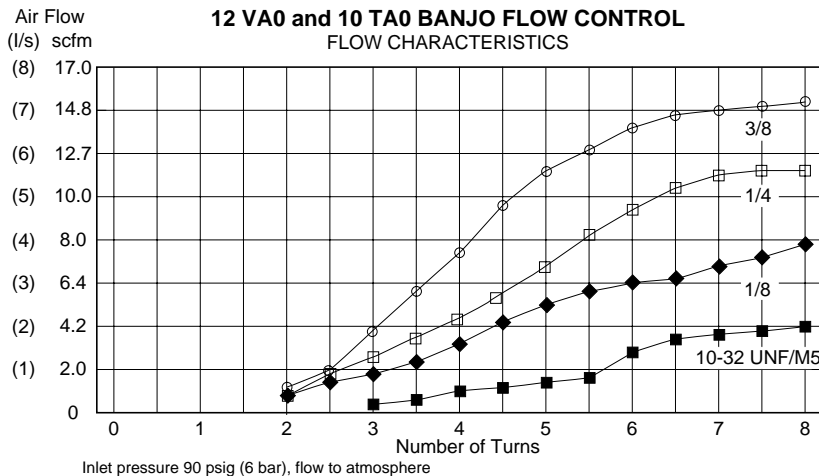

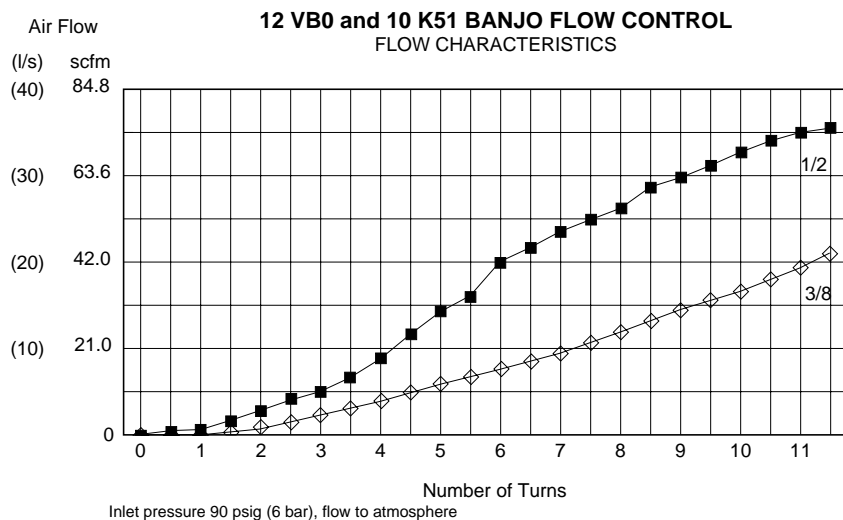
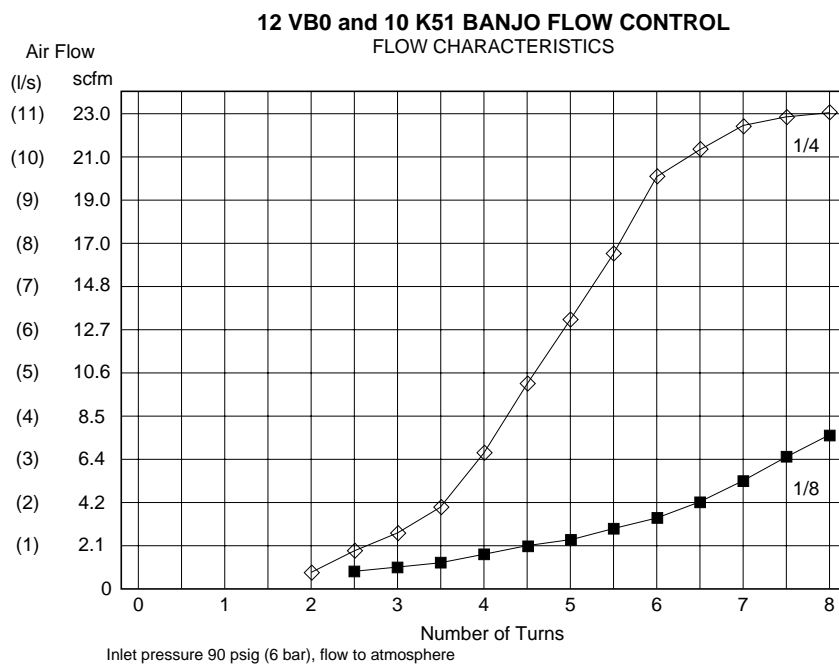
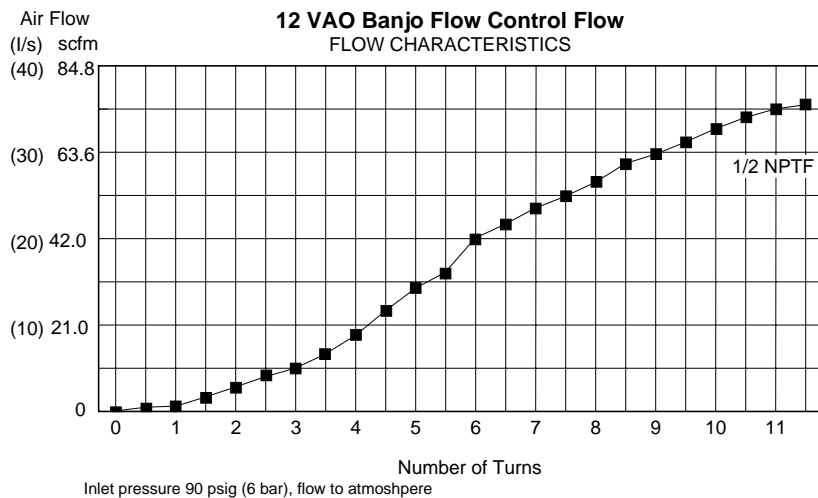

- Compact size/low weight/In-line units
- High Flow Performance
- Suitable for panel and wall mounting
- Provides linear flow adjustment
- Locking adjustment
- Captive adjustment needle will not blow out when unscrewed
- Index line on adjusting knob
- Available in 1/8, 1/4, 3/8, and 1/2 porting



Technical Data

Fluid: Compressed air, nitrogen, inert and non-combustible gases compatible with materials of construction.

Note: For other types of fluids or compressed gases, please consult factory.

Operation:

Uni-directional flow control.

Mounting:

In-line. Panel mounted by hexagonal mounting nut. Wall mounted via through-holes in regulator body.

Port size: NPT

1/8	T1000A1800
1/4	T1000A2800
3/8	T1000A3800
1/2	T1000A4800

ISO G

T1000C1800
T1000C2800
T1000C3800
T1000C4800

Operating pressure:

15 to 145 psig (1-10 bar)

Operating Temperature:

0° to 175°F (-20° to 80°C)

Consult our technical service for use below 35°F (2°C)

Opening Pressure (N-R Valve)

15 psig (1 bar)

Materials

1/8, 1/4: Aluminum alloy body, Nitrile seals, brass needle and internal parts, external parts in aluminum alloy.

3/8, 1/2: Aluminum alloy body, Nitrile seals, brass needle and internal parts, external parts in aluminum alloy.

Ordering Information

To order, quote product number from table on page FIT-3-7: i.e. T1000A2800 for 1/4 NPT model.

Alternate Models:

T1000M0500 - M5

T1100C1800 - 1/8" Bi-directional ISO G

T1100A1800 - 1/8" Bi-directional NPT

T1100C2800 - 1/4" Bi-directional ISO G

T1100A2800 - 1/4" Bi-directional NPT

ISO Symbol

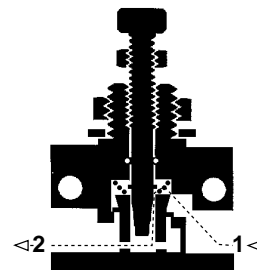
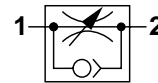



Model T1000A and T1000C

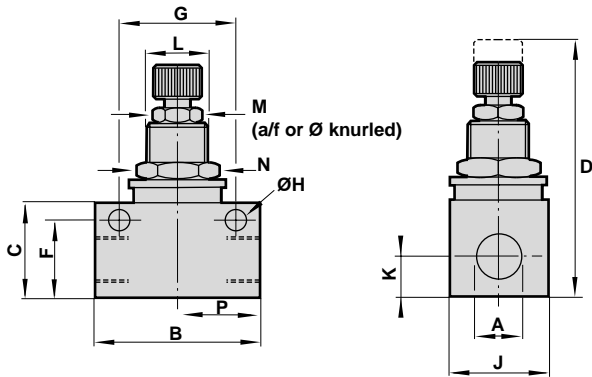

Model	Cv Regulating NPT port	Cv Free Flow NPT port	Weight grams oz. (g)
T1000A1800	0.14	0.37	1.1 (31)
T1000A2800	0.32	0.69	2.0 (56)
T1000A3800	1.00	1.45	5.3 (150)
T1000A4800	1.60	1.90	6.3(180)

Model	A	B	C	D	F	G	H	J	K	L	A/F M	N	P	PanelMax Hole	Panel Thickness
T1000A1800	1/8 NPT	1.33 (34.0)	0.79 (20.0)	2.0 (51.0)	0.65 (16.5)	0.94 (24.0)	0.18 (4.5)	0.63 (16.0)	0.38 (8.0)	M12 x 1 -	0.39 (Ø10.0)	0.55 (14.0)	0.67 (17.0)	0.49 (12.5)	0.16 (4.0)
T1000A2800	1/4 NPT	1.77 (45.0)	1.0 (25.4)	2.42 (61.5)	0.82 (20.8)	1.26 (32.0)	0.18 (4.5)	0.75 (19.0)	0.38 (9.7)	M14 x 1 -	0.39 (Ø10.0)	0.67 (17.0)	0.89 (22.5)	0.57 (14.5)	0.16 (4.0)
T1000A3800	3/8 NPT	2.28 (58.0)	1.28 (32.5)	3.09 (78.5)	1.06 (27.0)	1.69 (43.0)	0.26 (6.5)	1.10 (28.0)	0.51 (13.0)	M20 x 1 -	0.39(a/f) (14.0)	0.94 (24.0)	1.14 (29.0)	0.81 (20.5)	0.16 (4.0)
T1000A4800	1/2 NPT	2.56 (65.0)	1.42 (36.0)	3.23 (82.0)	1.20 (30.5)	1.97 (50.0)	0.26 (6.5)	1.18 (30.0)	0.29 (15.0)	M20 x 1 -	0.39 (a/f) (14.0)	0.94 (24.0)	1.28 (32.5)	0.81 (20.5)	0.16 (4.0)

NPT according to ANSI B 1.20.1

Flow vs Turns at 90 psi (6 bar)

T1000A1800

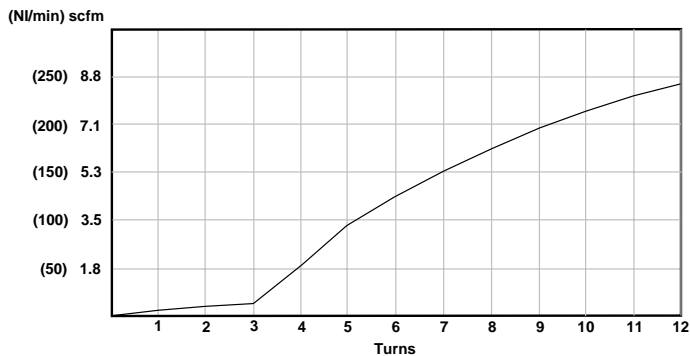

T1000A2800

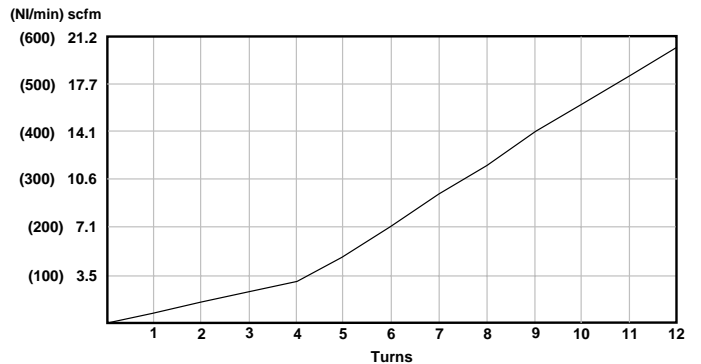

T1000A3800

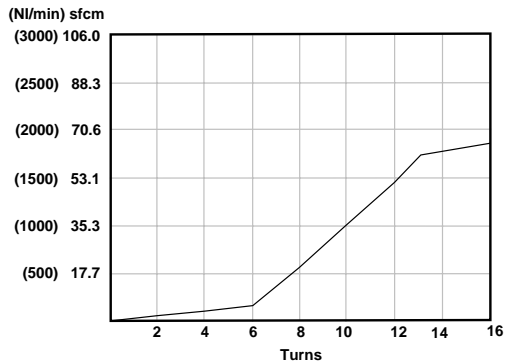

T1000A4800

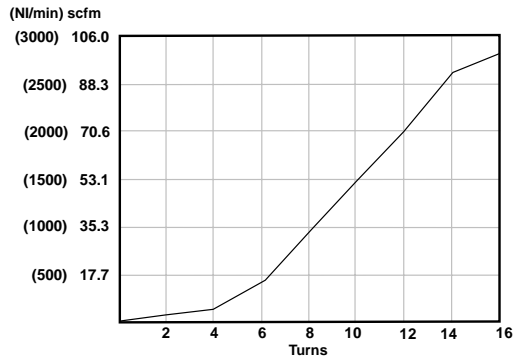

Push-In Flow Regulators

T-15 Series

Ø 3, 4, 5, 6, 10, 12 mm O/D Tube

- High flow performance
- Suitable for panel/wall mounting and manifold
- Adjustment can be locked
- Captive regulator needle will not blow out when unscrewed
- Adjusting knob position
- Releasable grab ring technology combining plastic and brass components for a compact and superior fitting design
- Color coding option with tamper-resistant feature
- Red release sleeve indicating metric tube sizes
- Grey release sleeve indicating inch tube sizes
- Reliable and corrosion resistant



Technical Data

Medium: Compressed Air, filtered

Operation: Uni-directional

Operating Pressure:

1.5 to 145 psig (0.1 to 10 bar)

Ambient Temperature:

0° to 175°F (-20°C* to 80°C)

Consult our Technical Service for use below 35°F (2°C)

Mounting:

In-line. Panel mounted by hexagonal mounting nut. Wall mounted by through-holes in regulator body. Manifold by quick connection

Alternative Models

Block form flow regulators, T1000 series

Heavy duty flow regulators, M/800, M/600

Precision flow regulators, M/650, M677 and S/790

Materials

1/8" (3mm), 5/32" (4mm), 3/16" (5mm), 1/4" (6mm),

5/16" (8mm), 3/8" (10mm)

Body: plastic PBT

Seals: silicone free nitrile seal, external metal parts: nickel plated brass

Internal parts: brass

Spring: stainless steel

Grab ring: stainless steel, BS 1440 Pt 2, grade 301.S21

Knob and panel nut: plastic POM

3/16" (5mm), – 1/2" (12mm)

Collet: nickel plated brass

Ordering Information

To order, quote model number from table on page FIT-3-9, e.g. T15Y0004 to order 1/4" model.

ISO Symbol

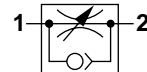



Push-In Flow Regulators

T-15

Metric Tube	Model	Inch Tube	Model	Maxi regulated flow factor C/Cv**	Free flow factor C/Cv**	oz (kg)
3 mm	T15P0003	1/8"	T15Y0001	0.07 (0.3)	0.07 (0.3)	.46 (0.013)
4 mm	T15P0004	5/32"	T15Y0002	0.11 (0.45)	0.11 (0.45)	.46 (0.013)
5 mm	T15P0005*	3/16"	T15Y0003*	0.21 (0.85)	0.21 (0.85)	1.13 (0.032)
6 mm	T15P0006	1/4"	T15Y0004	0.32 (1.3)	0.32 (1.3)	.99 (0.028)
8 mm	T15P0008	5/16"	T15Y0005	0.54 (2.2)	0.54 (2.2)	1.66 (0.047)
10 mm	T15P0010	3/8"	T15Y0006	0.71 (2.9)	0.78 (3.2)	3.28 (0.093)
12 mm	T15P0012*	1/2"	T15Y0007*	1.32 (5.4)	1.32 (5.4)	.50 (0.0143)

* Available in collet system

** C measured in dm³/(s.bar) Cv measured in US gal/min

T15

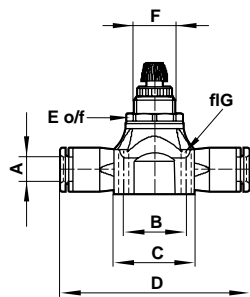

Metric	A	B	C	D	E	F	ØG
T15P0003	0.12 (3)	0.51 (13)	0.67 (17)	1.81 (46)	0.51 (13)	M10x1	0.09 (2)
T15P0004	0.16(4)	0.51 (13)	0.67 (17)	1.81 (46)	0.51 (13)	M10x1	0.09 (2)
T15P0005	0.20(5)	0.75 (19)	0.98 (25)	1.93 (49)	0.59 (15)	M12x1	0.14 (4)
T15P0006	0.24(6)	0.75 (19)	0.98 (25)	2.17 (55)	0.59 (15)	M12x1	0.14 (4)
T15P0008	0.31(8)	0.83 (21)	1.06 (27)	2.58 (66)	0.71 (18)	M14x1.5	0.14 (4)
T15P0010	0.39(10)	1.04 (27)	1.34 (34)	3.02 (77)	0.94 (24)	M20x1.5	0.17 (4)
T15P0012	0.47(12)	1.12 (29)	1.42 (36)	3.64 (93)	0.94 (24)	M20x1.5	0.17 (4)
Inch	A	B	C	D	E	F	ØG
T15Y0003	1/8	0.51 (13)	0.67 (17)	1.81 (46)	0.51 (13)	M10x1	0.09 (2)
T15Y0004	5/32	0.51 (13)	0.67 (17)	1.81 (46)	0.51 (13)	M10x1	0.09 (2)
T15Y0005	3/16	0.75 (19)	0.98 (25)	1.93 (49)	0.59 (15)	M12x1	0.14 (4)
T15Y0006	1/4	0.75 (19)	0.98 (25)	2.17 (55)	0.59 (15)	M12x1	0.14 (4)
T15Y0008	5/16	0.83 (21)	1.06 (27)	2.58 (66)	0.71 (18)	M14x1.5	0.14 (4)
T15Y0010	3/8	1.04 (27)	1.34 (34)	3.02 (77)	0.94 (24)	M20x1.5	0.17 (4)
T15Y0012	1/2	1.12 (29)	1.42 (36)	3.64 (93)	0.94 (24)	M20x1.5	0.17 (4)

Flow vs turns at 6 bar - flow in dm³/s ANR

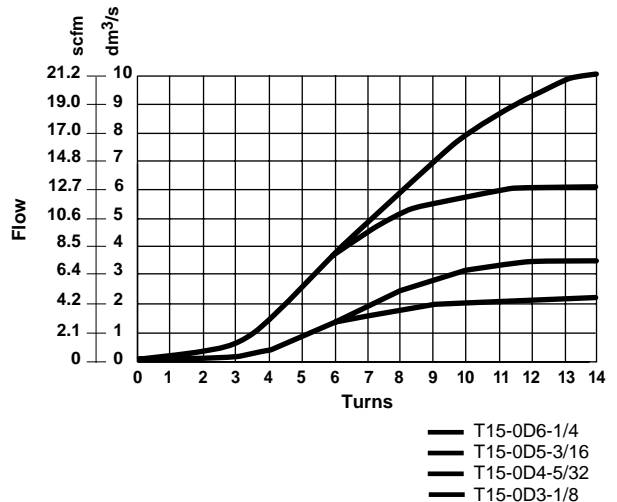
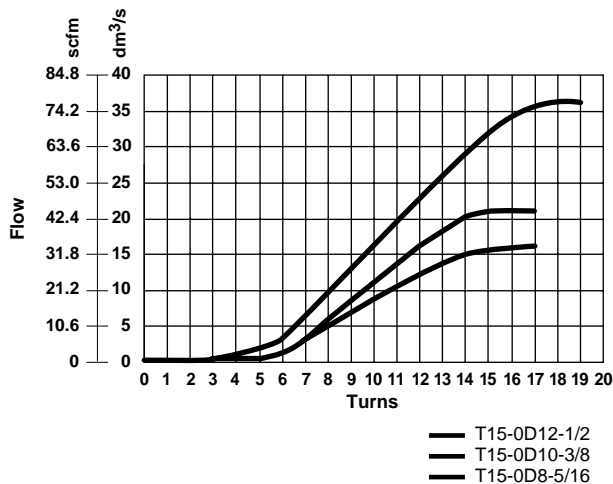

- In-line general purpose flow controls
- Captive adjustment needle will not blow out when unscrewed
- Lockable, calibrated adjustment knob
- Suitable for wall mounting
- High operating pressure



Technical Data

Fluid: Compressed air, nitrogen, inert and non-combustible gases compatible with materials of construction.

Note: For other types of fluids or compressed gases, please consult factory.

Operation: Uni-directional

Mounting:

Line mounted, concentrically

Port Size:

	NPT		ISO G		Weight lbs. (Kg)
1/8 NPT	C/836	G1/8	S/836		.22 (.10)
1/4 NPT	C/837	G1/4	M/837		.33 (.15)
1/2 NPT	C/839	G1/2	M/839		1.32 (.60)
3/4 NPT	C/840	G3/4	M/840		2.65 (1.20)
1 NPT	C/855	G1	M/855		7.72 (3.50)

Operating Pressure:

5 - 230 psig (0.3 - 16 bar)

Operating Temperature:

0°* to 175°F (-20° to +80°C) (Alternative models to 300°F [150°C])

* Consult our Technical Service for use below 35°F (2°C.)

Materials

Brass body, adjusting knob, and locking ring (C/836, C/837, C/839), aluminum body, adjusting knob and locking ring (C/840, C/855), nitrile rubber seals.

Repair Kits

Product Number		Kit Number	
NPT	ISO G	NPT	ISO G
C/836	S/836	QC/520/00	QS/520/00
C/837	M/837	QC/521/00	QS/521/00
C/839	M/839	QC/822/00	QS/522/00
C/840	M/840	QC/523/00	QS/523/00
C/855	M/855	QC/524/00	QS/524/00

Ordering Information

To order, quote model number from table on page FIT-3-11, e.g. C/837 for the 1/4" NPT model

Alternative models

C/600 range of heavy duty panel mounting Flow Controls (air & hydraulic), see page FIT-3-12.

T1000 range of Inline Flow Controls, see page FIT-3-6.

TM, TC/800 High Temperature version (150° C max.)

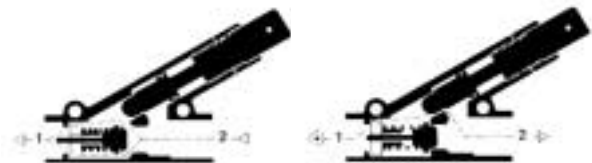
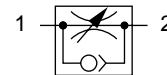

Function Fittings and Flow Controls

Dimensions in Inches (mm)



Flow Control

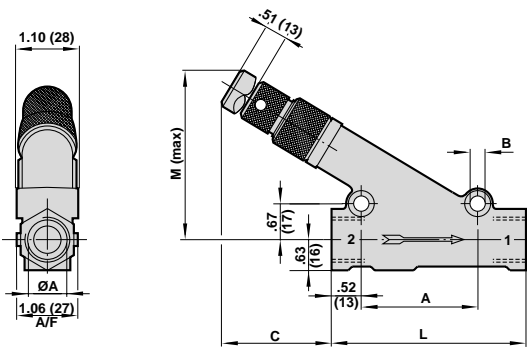

Thread	NPT	G	A	L	C	B	M (max)	D
1/8	C/836	S/836	.96 (25)	1.81 (46)	1.06 (27)	.33 (8)	3.11 (79)	.67 (17)
1/4	C/837	M/837	1.63 (42)	2.36 (60)	.98 (25)	.20 (5)	1.46 (37)	.87 (22)
1/2	C/839	M/839	2.25 (57)	3.7 (94)	2.09 (53)	.33 (8)	3.11 (79)	1.10 (28)
3/4	C/840	M/840	2.99 (76)	4.69 (119)	2.60 (66)	.34 (9)	4.09 (104)	1.38 (35)
1	C/855	M/855	3.54 (90)	5.90 (150)	4.22 (107)	.51 (13)	5.79 (147)	2.04 (52)

Typical Model Number: **C/839**
M/839

ØA
1/2 NPT
G1/2

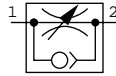

Type: Uni-directional
Free flow is from '2' to '1', indicated by arrow

Port	Model		Max. Regulating Flow Cv	Max. Free Flow Cv
	NPT	ISO G		
1/8	C/836	S/836	0.17	0.6
1/4	C/837	M/837	0.49	1.0
1/2	C/839	M/839	2.6	3.6
3/4	C/840	M/840	3.7	6.5
1	C/855	M/855	8.4	8.9

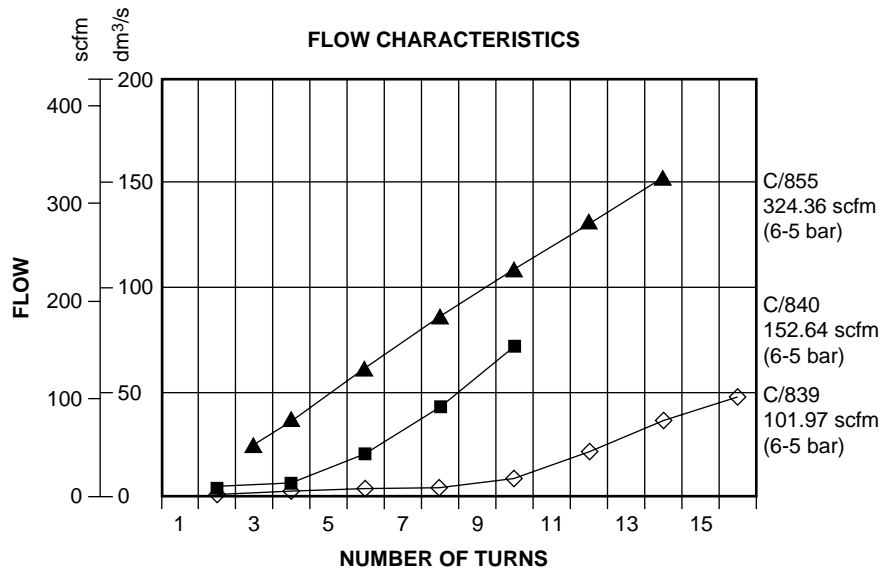
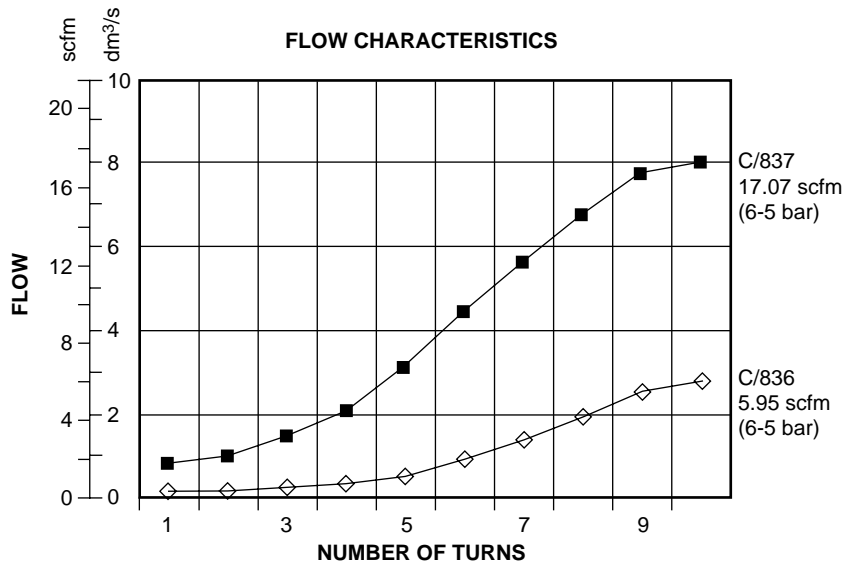

- Panel mounted general purpose flow controls
- Captive adjustment needle will not blow out when unscrewed
- Calibrated adjusting knob, can be locked on 1/8 and 1/2 models
- Panel mount legend plate indicating direction of flow control supplied as standard
- High operating pressure

Technical Data

Fluid: Compressed air, nitrogen, inert and non-combustible gases compatible with materials of construction.

Note: For other types of fluids or compressed gases, please consult factory.

Operation:

Uni-directional

Mounting:

Panel mounted

Port Sizes:

	NPT	ISO G	Weight lbs. (Kg)
1/8 NPT	C/636	G1/8 S/636	.29 (.13)
1/4 NPT	C/637	G1/4 M/637	.49 (.22)
1/2 NPT	C/639	G1/2 M/639	1.72 (.78)

Operating Pressure:

5 - 230 psig (0.3 - 16 bar)

Operating Temperature:

0°* to 175°F (-20° to 80°C)

*Consult our Technical Service for use below 35°F (2°C)

Flow

Product	Port Size	Cv Max Reg Flow	Cv Max Free Flow
C/636	1/8"	0.17	0.51
C/637	1/4"	0.49	1.05
C/639	1/2"	2.94	4.16

Materials

Brass body, chromium plated adjusting knob, locking ring and panel mounting ring, nitrile rubber seals.

Spares Kits

Product Number		Kit Number	
NPT	ISO G	NPT	ISO G
C/636	S/636	QC/520/00	QS/520/00
C/637	M/637	QC/521/00	QS/521/00
C/639	M/639	QC/522/00	QS/522/00



Ordering Information

To order, quote model number from table on page FIT-3-12, e.g. C/637 for the 1/4" model

Alternative models

C/800 range of Heavy duty flow controls, see page FIT-3-10.

T1000 range of In-Line Flow Controls, see page FIT-3-6.

TM, TC/800 high temperature version 300°F (150°C) max.

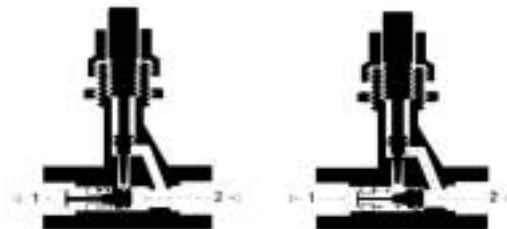
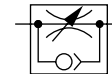



Panel Mounted Flow Control

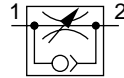
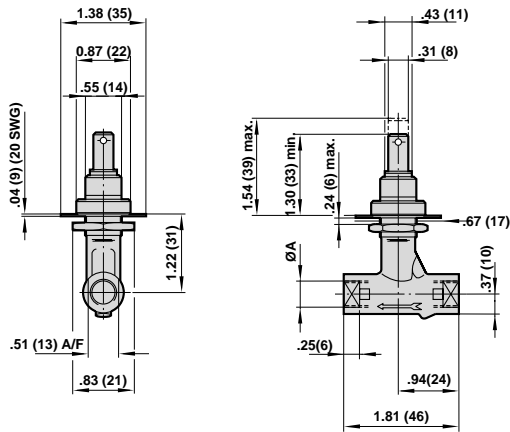

Model Number: **C/636** ØA
 S/636 **1/8 NPT**
 G1/8

Type: Uni-directional
 Free flow is from '2' to '1', indicated by arrow

Panel Mounted Flow Control

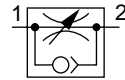
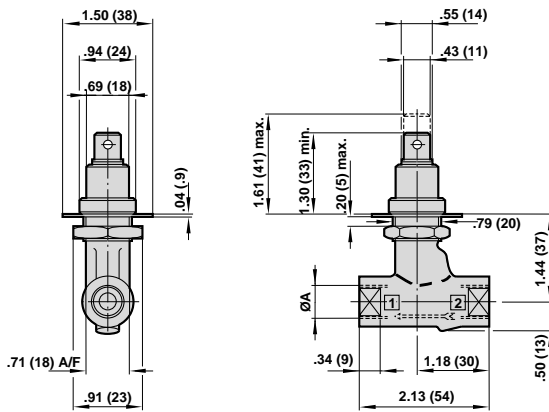

Model Number: **C/637** ØA
 M/637 **1/4 NPT**
 G1/4

Type: Uni-directional
 Free flow is from '2' to '1', indicated by arrow

Panel Mounted Flow Control

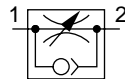
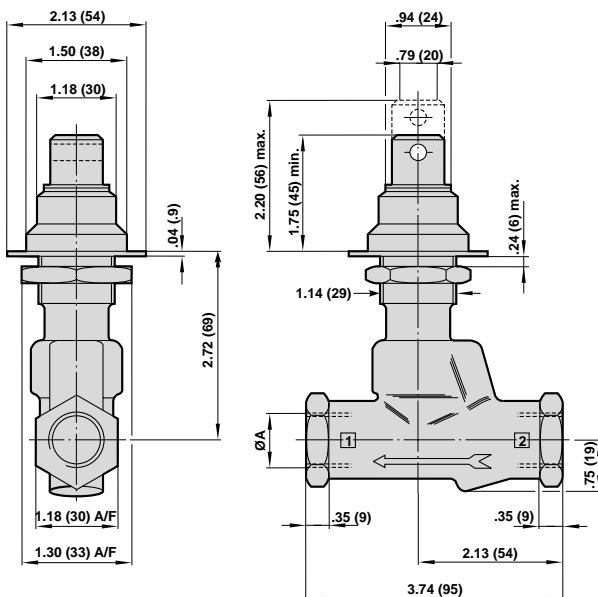

Model Number: **C/639** ØA
 M/639 **1/2 NPT**
 G1/2

Type: Uni-directional
 Free flow is from '2' to '1', indicated by arrow

- Allow free flow in one direction only
- Low cracking pressure
- PIF-PIF, PIF-Male and Male-PIF alternatives
- Non-PTFE based thread sealant on taper threads
- Releasable grab ring technology combining plastic and brass components for a compact and superior fitting design
- Molded mounting brackets on tub connector designs
- Low weight design
- Red release sleeve indicating metric tube sizes
- Grey release sleeve indicating inch tube sizes
- Easy tube insertion for rapid and quick assembly of pneumatic circuits
- Reliable and corrosion resistant
- Silicon free
- Color coding option with tamper-resistant feature



Technical Data

Medium: Compressed Air, filtered, lubricated or non-lubricated, vacuum

Operating Pressure:

- 1.5 to 145 psig (0.1 to 10 bar) (T51, T52)
- 4.4 to 145 psig (0.3 to 10 bar) (T53)
- 1.5 to -14.5 psig (-0.1 to -1 bar) vacuum (T51, T52)

Ambient Temperature:

- 0° to 175°F (-20°C* to 80°C)
- Consult our Technical Service for use below 35°F (2°C)

Mounting:

- Tube/tube PIF
- Tube PIF/male thread
- Male threaded/tube PIF

Alternative Models

T55, T56 range of aluminum threaded non return valves.
TS/520 range of brass threaded non return valve.

Materials

OD 4-0D8

Body: Plastic PBT
Seal: Silicon free nitrile
Valve: Plastic PBT
Insert: Natural brass
Spring: Stainless steel
Grab Ring: Stainless steel - BS 1440
PT 2, grade 301.S21 (4-6-8 sizes)

OD-5 collet system

T-52 and T-53 series, nickel brass threads.

OD 10 - OD12 sizes

Collet: Nickel plated brass
Body: Black anodized aluminum
Valve and Insert: Aluminum

Ordering Information

To order, quote model number from table on page FIT-3-15, e.g. T51Y0004 for the 1/4" model.

NOTE: T51 and T52 flow is threaded end to push-in (check is in reverse).

T53 flow is from push-in to threaded end (check is in reverse).

ISO Symbol

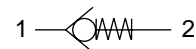



Inline Push-in Non Return Valves

T-51, T-52 and T-53 Series. Operating pressure: 10 bar (14 psi)

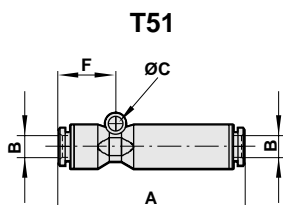

Inch PIF/PIF	Model #	Metric PIF/PIF	Model #
5/32"	T51Y0002	4	T51P0004
3/16"	T51Y0003*	5	T51P0005*
1/4"	T51Y0004	6	T51P0006
5/16"	T51Y0005	8	T51P0008
3/8"	T51Y0006*	10	T51P0010*
1/2"	T51Y0007*	12	T51P0012*

* Available only with collet tube connection

Inch Model	A	B	F	ØC
T51Y0002	49.8	5/32	15.5	4.3
T51Y0003*	53.1	3/16	15.2	4.3
T51Y0004	55.3	1/4	16.9	4.3
T51Y0005	62.5	5/16	19.0	4.3
T51Y0006*	77.4	3/8	-	-
T51Y0007*	88.4	1/2	-	-

Metric Model	A	B	F	ØC
T51P0004	48.8	4	15.5	4.3
T51P0005*	53.1	5	15.2	4.3
T51P0006	55.3	6	16.9	4.3
T51P0008	62.5	8	19.0	4.3
T51P0010*	77.4	10	-	-
T51P0012*	88.4	12	-	-

T52, T53

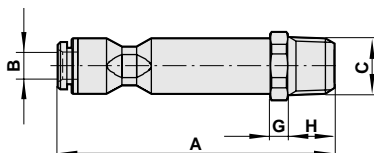

Inch PIF/Male Thrd.	Model #	Metric PIF/ISO Rc	Model #
5/32" x 1/8"	T52A1802	4 x M5	T52M0504
3/16" x 1/8"	T52A1803*	4 x 1/8"	T52B1804
3/16" x 1/4"	T52A2803*	5 x 1/8"	T52B1805*
1/4" x 1/8"	T52A1804	5 x 1/4"	T52B2805*
1/4" x 1/4"	T52A2804	6 x 1/8"	T52B1806
5/16" x 1/8"	T52A1805*	6 x 1/4"	T52B2806
5/16" x 1/4"	T52A2805	8 x 1/8"	T52B1808
		8 x 1/4"	T52B2808

Inch Male Thrd./PIF	Model #	Metric ISO Rc/PIF	Model #
1/8 x 5/32"	T53A1802	M5 x 4	T53M0504
1/8 x 3/16"	T53A1803*	1/8 x 4	T53B1804
1/4 x 3/16"	T53A2803*	1/8 x 5	T53B1805*
1/8 x 1/4"	T53A1804	1/4 x 5	T53B2805*
1/4 x 1/4"	T53A2804	1/8 x 6	T53B1806
1/8 x 5/16"	T53A1805	1/4 x 6	T53B2806
1/4 x 5/16"	T53A2805	1/8 x 8	T53B1808
		1/4 x 8	T53B2808

Inch Model	A	B	C**	G	H
T52A1802	54.4	5/32	1/8	4	9.5
T52A1803*	57.9	3/16	1/8	4	9.5
T52A2803*	62.7	3/16	1/4	4	14.3
T52A1804	59.2	1/4	1/8	4	9.5
T52A2804	64	1/4	1/4	4	14.3
T52A1805	63.7	1/8	1/8	4	9.5
T52A2805	68.5	1/4	1/4	4	14.3

** NPTF

Metric Model	A	B	C**	G	H
T52M0504	49.2	4	M5	4	4.3
T52B1804	54.4	4	1/8	4	9.5
T52B1805*	57.9	5	1/8	4	9.5
T52B2805*	59.4	5	1/4	4	11
T52B1806	59.2	6	1/8	4	9.5
T52B2806	60.7	6	1/4	4	11
T52B1808	63.7	8	1/8	4	9.5
T52B2808	65.2	8	1/4	4	11

** BSPT

Non-Return Valves T55, T56 Series

In-Line, Non-Return Valves
M5, 1/8", 1/4", 3/8, 1/2" ISO G, ISO R, NPT

- Permits free flow of air in one direction only
- Simple, reliable design
- Light weight
- Silicone free
- Low cracking pressure
- T56 male connections have an O-ring in parallel threads



Technical Data

Medium:

Compressed air, filtered, lubricated and non-lubricated

Operation:

Non-return valve

Mounting:

Line mounted

Port Sizes:

Metric	ISO G	ISO Rc	NPT
M5 T55M0500	G1/8 T55C1800	Rc1/8 T55B1800	1/8 NPT T55A1800
	G1/4 T55C2800	Rc1/4 T55B2800	1/4 NPT T55A2800
	G3/8 T55C3800	Rc3/8 T55B3800	3/8 NPT T55A3800
	G1/2 T55C4800	Rc1/2 T55B4800	1/2 NPT T55A4800
	G3/4 TS/523		3/4 NPT TC/523
	G1 TS/524		1 NPT TC/524

*High temperature viton seals

Operating Pressure:

1.5 - 145 psi (0.1 - 10 bar)

5 - 230 psi (0.3 - 16 bar)

Operating Temperature:

0°* to 300°F (-20°* to +150°C)

*Consult our Technical Service for use below 35°F (2°C). For high temperature applications (300°F [150°C] Max) TM, TC/520 Series version should be ordered

Materials

T55: Aluminum body (T55), brass (T56), silicone free nitrile rubber 'O' ring, POM valve, stainless steel spring.

TC/TS: Brass body, aluminum valve

High temp viton seals

Ordering Information

To order, quote model number from table on page FIT-3-17, e.g. C/521 for the 1/4 NPT model

Alternative Models

T51 Series in-line push-in non-return valves, see page FIT-3-14

ISO Symbol





T55 Series

Port Size	Flow Factor Cv**	Flow Factor C*	Cracking pressure (bar)	oz (kg)	Model Metric	BSPB	BSPT	NPT
M5	0.19	0.8	0.73 (0.05)	0.35 (0.010)		T55M0500	T55B1800	T55A1800
1/8	0.59	2.4	0.73 (0.05)	0.53 (0.015)		T55C1800	T55B2800	T55A2800
1/4	1.35	5.5	0.73 (0.05)	0.88 (0.025)		T55C2800	T55B3800	T55A3800
3/8	2.20	9.0	0.73 (0.05)	2.12 (0.060)		T55C3800	T55B4800	T55A4800
1/2	3.70	15.0	0.73 (0.05)	2.82 (0.080)		T55C4800		

* C measured in dm³/(s.bar) ** Cv measured in US gal/min.

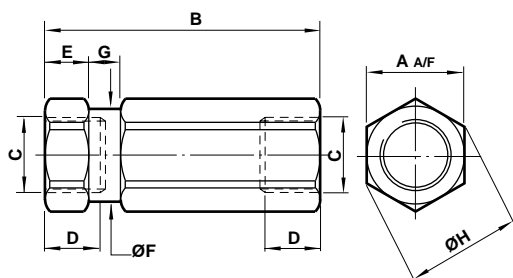

Model	A	B	C	D	E	F	G	H
T55M0500	.43 (11)	1.08 (27.5)	(M5)	.20 (5)	.16 (4)	.42 (10.7)	.12 (3)	.47 (12)
T55A1800	.55 (14)	1.67 (42.5)	(1/8)	-	.28 (7)	.54 (13.7)	.16 (4)	.59 (15)
T55B1800	.55 (14)	1.67 (42.5)	(1/8)	-	.28 (7)	.54 (13.7)	.16 (4)	.59 (15)
T55C1800	.55 (14)	1.67 (42.5)	(1/8)	.28 (7)	.28 (7)	.54 (13.7)	.16 (4)	.59 (15)
T55A2800	.67 (17)	2.13 (54)	(1/4)	-	.31 (8)	.66 (16.7)	.20 (5)	.73 (18.5)
T55B2800	.67 (17)	2.13 (54)	(1/4)	-	.31 (8)	.66 (16.7)	.20 (5)	.73 (18.5)
T55C2800	.67 (17)	2.13 (54)	(1/4)	.41 (10.5)	.31 (8)	.66 (16.7)	.20 (5)	.73 (18.5)
T55A3800	.94 (24)	2.48 (63)	(3/8)	-	.35 (9)	.93 (23.7)	.28 (7)	1.02 (26)
T55B3800	.94 (24)	2.48 (63)	(3/8)	-	.35 (9)	.93 (23.7)	.28 (7)	1.02 (26)
T55C3800	.94 (24)	2.48 (63)	(3/8)	.47 (12)	.35 (9)	.93 (23.7)	.28 (7)	1.02 (26)
T55A4800	1.06 (27)	3.03 (77)	(1/2)	-	.47 (12)	1.05 (26.7)	.39 (10)	1.18 (30)
T55B4800	1.06 (27)	3.03 (77)	(1/2)	-	.47 (12)	1.05 (26.7)	.39 (10)	1.18 (30)
T55C4800	1.06 (27)	3.03 (77)	(1/2)	.59 (15)	.47 (12)	1.05 (26.7)	.39 (10)	1.18 (30)

* Available only with collet tube connection

T56 Series

Port Size	Flow Factor Cv**	Flow Factor C*	Cracking pressure (bar)	oz (kg)	Model Metric	BSPB	BSPT	NPT
M5	0.19	0.55	0.73 (0.05)	0.64 (0.018)	T56M0500			
1/8	0.59	2.4	0.73 (0.05)	1.59 (0.045)		T56C1800	T56B1800	T56A1800
1/4	1.23	5.0	0.73 (0.05)	2.82 (0.080)		T56C2800	T56B2800	T56A2800

* C measured in dm³/(s.bar) ** Cv measured in US gal/min.

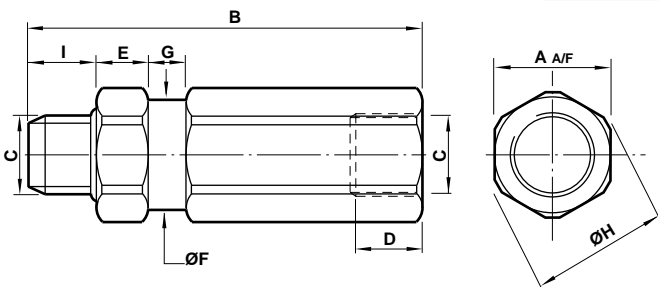

Model	A	B	C	D	F	G	H	I
T56M0500	.43 (11)	1.25 (31.8)	(M5)	.20 (5)	.42 (10.7)	.12 (3)	.47 (12)	.17 (4.3)
T56A1800	.55 (14)	1.93 (49)	(1/8)	(-)	.54 (13.7)	.16 (4)	.59 (15)	.37 (9.5)
T56B1800	.55 (14)	1.93 (49)	(1/8)	(-)	.54 (13.7)	.16 (4)	.59 (15)	.37 (9.5)
T56C1800	.55 (14)	1.77 (45)	(1/8)	.28 (7)	.54 (13.7)	.16 (4)	.59 (15)	.22 (5.5)
T56A2800	.67 (17)	2.46 (62.5)	(1/4)	(-)	.66 (16.7)	.20 (5)	.73 (18.5)	.56 (14.3)
T56B2800	.67 (17)	2.32 (59)	(1/4)	(-)	.66 (16.7)	.20 (5)	.73 (18.5)	.43 (11)
T56C2800	.67 (17)	2.21 (56.2)	(1/4)	.41 (10.5)	.66 (16.7)	.20 (5)	.73 (18.5)	.31 (8)

- Assists in complying with OSHA and related safety regulations
- Tamper proof
- Compact
- Low pressure drop
- Automatically resets after failure correction
- High air pressure rating



Technical Data

Fluid: Compressed air, nitrogen, inert and non-combustible gases compatible with materials of construction.

Note: For other types of fluids or compressed gases, please consult factory.

Operation:

Fixed uni-directional excess flow automatic shut off valve (air fuse)

Mounting:

In-line two way valve

To be inserted between fixed air supply and flexible air lines

See guidelines for typical installation

Port Size: Female Thread

NPT		ISO G	
1/4 NPT	T60A289*	G 1/4	T60C289*
3/8 NPT	T60A389*	G 3/8	T60C389*
1/2 NPT	T60A489*	G 1/2	T60C489*
3/4 NPT	T60A689*	G 3/4	T60C689*
1 NPT	T60A889*	G 1	T60C889*
1-1/2 NPT	T60A889*	G 1-1/2	T60CB89*

* Last digit depends on flow range

Operating Pressure:

Maximum 232 psi (16 bar)

Minimum according to hose length

Drop pressure at shut-off flow: 2 to 4.5 psi (0.14 or 0.3 bar)

Operating Temperature:

0^{***} to 175° F (-20° to 80°C)

**Consult our Technical Service for use below 35°F (2°C)

At low temperature ensure air fuse is not subjected to freezing conditions which may prevent its function.

Materials

Aluminium body, brass internal parts, stainless steel spring

Ordering Information

To order, quote appropriate product number from the tables on the following pages. i.e. T60A2890 for the 1/4 NPT with 2 psi pressure drop at shut off.

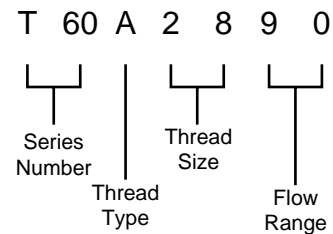

Simplified Symbol

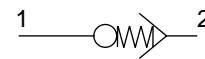

ISO Symbol

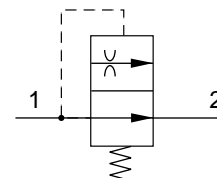



General Information

Model		Port size	Drop pressure at shut off flow		Shut off flow rate at		Flow at 100 psi (7 bar) ΔP 1 psi (0.07 bar)		Weight	
NPT	ISO G		psi	(bar)	100 psi	(7 bar)	scfm	(dm³/s)	oz.	(Kg)
T60A2890	T60C2890	1/4	2.0	(.14)	17.6	(8)	13.8	(7)	1.4	(.04)
T60A2891	T60C2891		4.4	(.3)	29.7	(14)	13.8	(7)	1.4	(.04)
T60A3890	T60C3890	3/8	2.0	(.14)	41.1	(19)	28.6	(14)	2.3	(.07)
T60A3891	T60C3891		4.4	(.3)	68.2	(32)	28.6	(14)	2.3	(.07)
T60A4890	T60C4890	1/2	2.0	(.14)	68.2	(32)	49.2	(23)	5.3	(.15)
T60A4891	T60C4891		4.4	(.3)	102.3	(48)	49.2	(23)	5.3	(.15)
T60A6890	T60C6890	3/4	2.0	(.14)	102.3	(48)	91.1	(43)	4.6	(.13)
T60A6891	T60C6891		4.4	(.3)	169.5	(80)	91.1	(43)	4.6	(.13)
T60A8890	T60C8890	1	2.0	(.14)	195.0	(92)	144	(68)	19.0	(.54)
T60A8891	T60C8891		4.4	(.3)	271.0	(128)	144	(68)	19.0	(.54)
T60AB890	T60CB890	1-1/2	2.0	(.14)	394.0	(186)	307	(145)	38.8	(1)
T60AB891	T60CB891		4.4	(.3)	568.0	(268)	307	(145)	38.8	(1)

NPT : according to ANSI-B1.20.1.
ISO G : according to BS2779 and ISO-228/1

Flow and pressure test conducted according to ISO-6358 test circuit. Mean measured flow values are provided at standard reference conditions.

Air Fuse (Excess Flow Check)

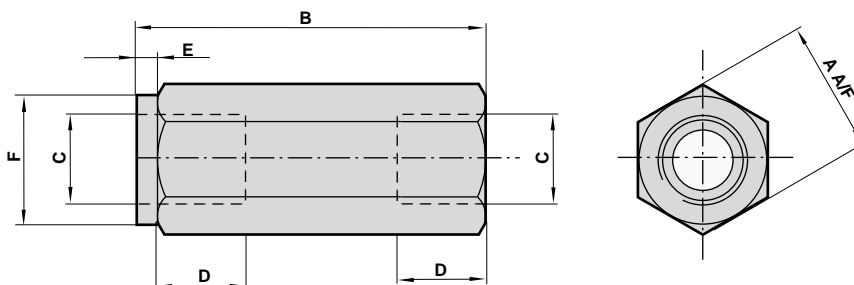

Model	T60A289*	T60C289*	T60A389*	T60C389*	T60A489*	T60C489*	T60A689*	T60C689*	T60A889*	T60C889*	T60AB89*	T60CB89*
	NPT	ISO G	NPT	ISO G	NPT	ISO G	NPT	ISO G	NPT	ISO G	NPT	ISO G
A	0.81 (21)	0.81 (21)	0.94 (24)	0.94 (24)	1.25 (32)	1.25 (32)	1.25 (32)	1.25 (32)	2.00 (51)	2.00 (51)	2.50 (64)	2.50 (64)
B	2.01 (51)	2.01 (51)	2.44 (62)	2.44 (62)	3.07 (78)	3.07 (78)	3.54 (90)	3.54 (90)	4.65 (118)	4.65 (118)	5.71 (145)	5.71 (145)
C	1/4	1/4	3/8	3/8	1/2	1/2	3/4	3/4	1.0	1.0	1.5	1.5
D	0.39 (10)	0.43 (11)	0.41 (10)	0.55 (14)	0.59 (15)	0.54 (14)	0.56 (14)	0.75 (19)	0.66 (17)	1.00 (26)	0.68 (17)	1.00 (26)
E	0.12 (3)	0.12 (3)	0.20 (5)	0.20 (5)	0.20 (5)	0.20 (5)	0.20 (5)	0.20 (5)	0.20 (5)	0.20 (5)	0.20 (5)	0.20 (5)
F	0.81 (21)	0.81 (21)	0.94 (24)	0.94 (24)	1.25 (32)	1.25 (32)	1.25 (32)	1.25 (32)	2.00 (51)	2.00 (51)	2.50 (64)	2.50 (64)



Guidelines for Typical Installation

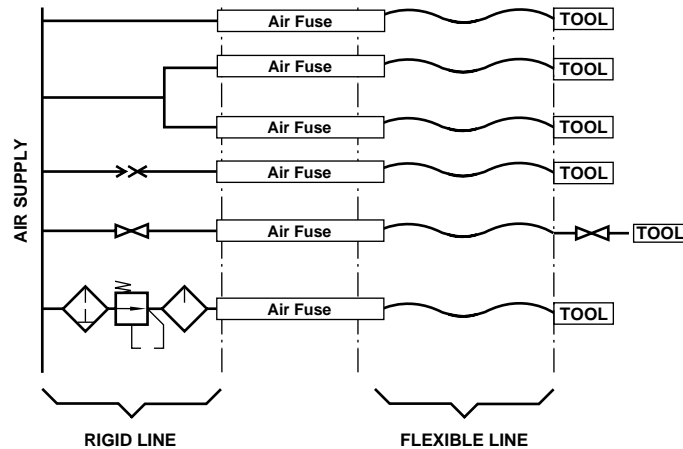

The air fuse should be installed directly between fixed or rigid pipework and the flexible tube to protect the whole length of the flexible tube. Only tubing **after** the air fuse is protected. The air fuse must be installed in the correct orientation. Failure to do this will render it ineffective. When a shut off valve is located before the air fuse, the valve must be opened slowly in order to control initial air flow and avoid decompression effects which may trip the air fuse.

It should be noted that the OSHA standard (29 CFR ChXVII Para 1926.302-b7) relating to pneumatic power tools states "All hoses exceeding 1/2" inside diameter shall have a safety device at the source of supply or branch line to reduce pressure in the case of hose failure."

Choosing an Air Fuse*

- The port size of the air fuse should be nominally equal to that of the supply lines - e.g. a 1/2 (12.7 mm) air fuse should be used with a 1/2" (12.7mm) ID hose.
- Always select the high flow model (91) if there is sufficient system pressure for the length of hose to be protected. See tables hose length vs. minimum supply pressure.
- If there is insufficient system pressure, or long hose lengths are to be protected, use model 90.
- After installation always test each valve for proper function. See section below on how to check an air fuse.
- The pneumatic system must be capable of delivering the flow required to activate the air fuse. For this reason, the air fuse is not suitable for use with the Norgren R07 miniature range in certain installations.
- For use with spring coils consult table. See table flow vs. pressure supply.

Verifying Operation of an air fuse

- Install the air fuse following the instructions supplied
- Connect tool or complete circuit to the air line
- Switch on operation to ensure a complete cycle is performed
- If tool or complete circuit starts and runs satisfactorily, stop operation and drain air line. Disconnect hose from tool or circuit and secure hose end. Turn on air supply progressively (to avoid decompression effect). Prior to fully reaching operation conditions, the air fuse should suddenly activate and cut off the flow. A slight air flow will remain as part of the automatic re-set function. If the air fuse is not activated the unit should be disconnected and the lower flow range air fuse should be used.

* Consult factory for the availability of Excel™ based sizing program.



Hose length vs minimum pressure supply (1/4 to 3/8)

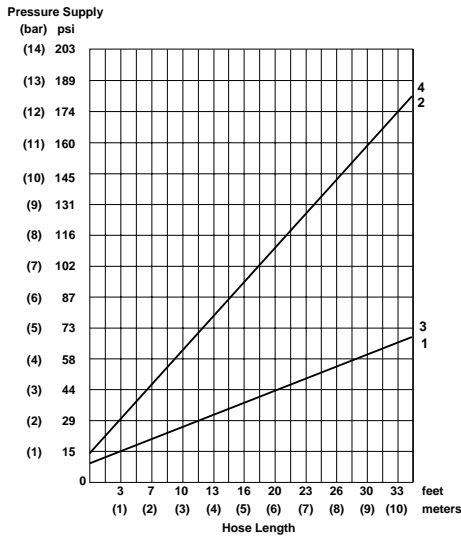

KEY

- 1 - T60 * 2890 ID = 0.30" (7.5mm)
- 2 - T60 * 2891 ID = 0.30" (7.5mm)
- 3 - T60 * 3890 ID = 0.35" (9.0mm)
- 4 - T60 * 3891 ID = 0.35" (9.0mm)

Hose length vs minimum pressure supply (1/2 to 3/4)

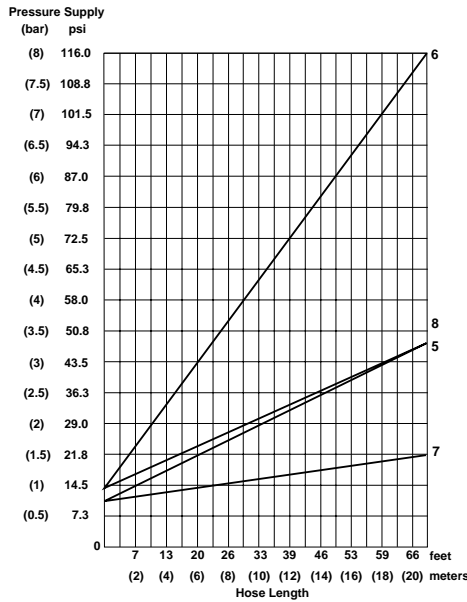

KEY

- 5 - T60 * 4890 ID = 0.51" (13mm)
- 6 - T60 * 4891 ID = 0.51" (13mm)
- 7 - T60 * 6890 ID = 0.75" (19mm)
- 8 - T60 * 6891 ID = 0.75" (19mm)

Hose length vs pressure supply (1 to 1-1/2)

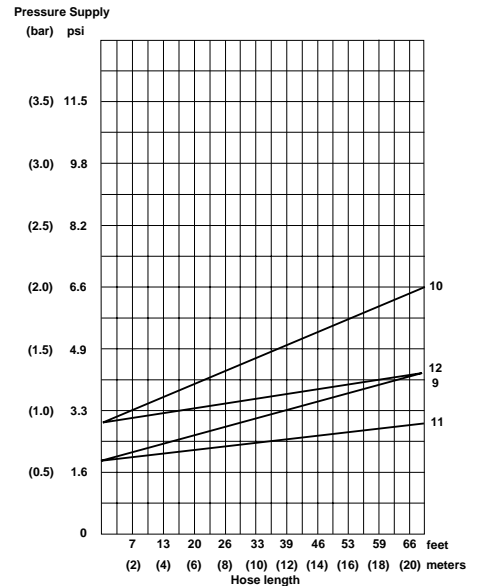

KEY

- 9 - T60 * 8890 ID = 1.00" (25.0mm)
- 10 - T60 * 8891 ID = 1.00" (25.4mm)
- 11 - T60 * B890 ID = 1.50" (38.1mm)
- 12 - T60 * B891 ID = 1.50" (38.1mm)

Flow (±10%) vs pressure supply (1/4 to 1/2)

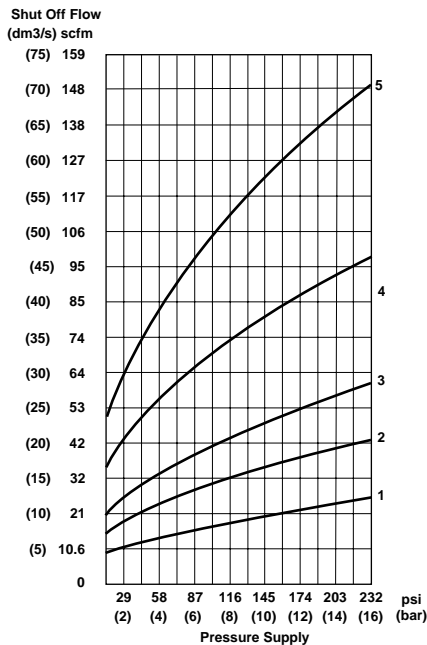

KEY

- 1 - T60 * 2890
- 2 - T60 * 2891
- 3 - T60 * 3890
- 4 - T60 * 3891
- 5 - T60 * 4891

Flow (±10%) vs pressure supply (3/4 to 1-1/2)

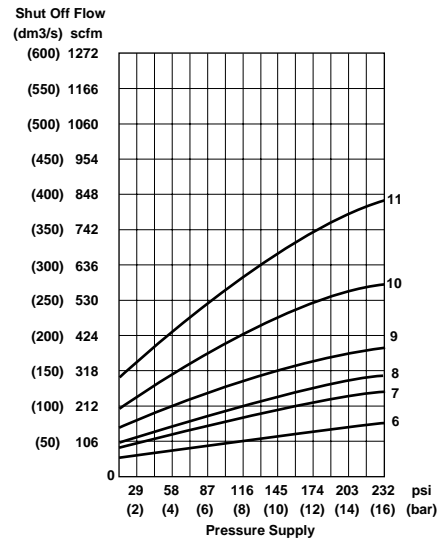

KEY

- 6 - T60 * 6890
- 7 - T60 * 6891
- 8 - T60 * 8890
- 9 - T60 * 8891
- 10 - T60 * B890
- 11 - T60 * B891

Measurements

- Flow and pressure tests conducted according to ISO-6358 test circuit
- Mean measured flow values are provided at standard reference condition 68°F, 15 psi, (20°C, 1.01 bar)
- Indicated pressure values are relative pressure in bar.

Hose Lengths

- Graphs are for indicated hose internal diameter in key.
- Consult our Technical Service for hose lengths and Internal diameters different from the recommended one.



Function Fittings and Flow Controls

Coiled hose selection table

Selection procedure for coiled hose:

Chose the thread size of your hose, the hose internal diameter in inches and the hose length in feet. The minimum supply pressure in psi is shown in the table below and the appropriate air fuse is shown in the left column. The “*” in the middle of the part number represents the thread type - put an “A” for NPT and a “C” for ISO G threads. If no value is shown, it may not be possible to protect your hose with an air fuse. If in doubt, consult a Norgren distributor or Norgren.

Valve Model	Thread Size	Hose length Feet	Internal Hose Diameter (inch)												
			0.125	0.188	0.215	0.250	0.313	0.370	0.470	0.500	0.590	0.750	1.000	1.250	1.500
T60*2890	1/4	12		124	64	29	16	11	8	8	8	7	7	7	7
T60*2890	1/4	25			126	52	25	14	9	9	8	7	7	7	7
T60*2890	1/4	50			244	97	42	21	11	10	8	8	7	7	7
T60*2890	1/4	100				187	76	35	15	13	10	8	7	7	7
T60*2891	1/4	12				70	31	17	10	9	8	7	7	7	7
T60*2891	1/4	25				137	57	27	13	11	9	8	7	7	7
T60*2891	1/4	50					107	47	19	15	11	8	7	7	7
T60*2891	1/4	100					207	87	30	23	14	9	8	7	7
T60*3890	3/8	12				125	52	25	12	11	9	8	7	7	7
T60*3890	3/8	25					102	45	18	15	10	8	7	7	7
T60*3890	3/8	50					196	82	29	22	14	9	8	7	7
T60*3890	3/8	100						157	50	38	20	11	8	7	7
T60*3891	3/8	12						132	57	21	17	11	8	7	7
T60*3891	3/8	25							111	37	28	16	10	8	7
T60*3891	3/8	50							215	67	49	25	12	8	7
T60*3891	3/8	100								126	91	42	17	9	7
T60*4890	1/2	12						132	57	21	17	11	8	7	7
T60*4890	1/2	25							111	37	28	16	10	8	7
T60*4890	1/2	50							215	67	49	25	12	8	7
T60*4890	1/2	100								126	91	42	17	9	7
T60*4891	1/2	12							119	39	30	17	10	8	7
T60*4891	1/2	25								74	54	27	13	8	7
T60*4891	1/2	50								141	102	46	18	10	8
T60*4891	1/2	100									196	85	29	12	8
T60*6890	3/4	12							119	39	30	17	10	8	7
T60*6890	3/4	25								74	54	27	13	8	7
T60*6890	3/4	50								141	102	46	18	10	8
T60*6890	3/4	100									196	85	29	12	8
T60*6891	3/4	12								96	70	33	15	9	7
T60*6891	3/4	25								193	139	62	23	11	8
T60*6891	3/4	50										116	38	14	8
T60*6891	3/4	100										224	69	20	9
T60*8890	1	12								123	89	41	17	9	7
T60*8890	1	25									178	78	27	12	8
T60*8890	1	50										148	47	16	8
T60*8890	1	100											88	24	9
T60*8891	1	12								231	166	73	26	11	8
T60*8891	1	25										144	46	16	8
T60*8891	1	50											85	24	9
T60*8891	1	100												163	11
T60*B890	1-1/2	12											147	47	8
T60*B890	1-1/2	25												90	9
T60*B890	1-1/2	50												173	11
T60*B890	1-1/2	100													16
T60*B891	1-1/2	12												89	9
T60*B891	1-1/2	25												179	12
T60*B891	1-1/2	50													16
T60*B891	1-1/2	100													24

Function Fittings and Flow Controls



Pressure Reducing Fitting Inch and Metric



- **Compact size**
- **Easy tube insertion for rapid assembly of pneumatic circuits**
- **Push-in and threaded ports**
- **Optimum pressure utilization**
- **Safer pneumatic systems**
- **Hex key adjustment and locking ring**
- **Relieving**

Ordering Information

To order, quote appropriate product number from the tables on the following pages.

Product numbering system is designed to make identification and selection simple:

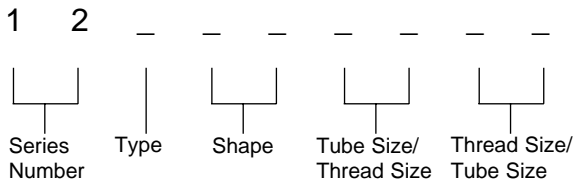

124GB

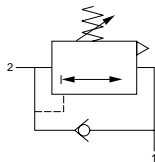

124GB

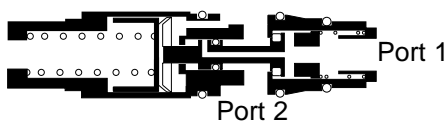

Technical Data

Fluid: Compressed air, nitrogen, inert and non-combustible gases compatible with materials of construction.

Note: For other types of fluids or compressed gases, please consult factory.

Operating Pressure:

Primary (inlet) pressure 0 to 150 psi (0 - 10 bar)

Maximum secondary (regulated) pressure 115 psi (8 bar)

Operating Temperature:

0° to 175°F (-20° to +80°C)

Outlet Port:

5/32", 1/4", 5/16", 3/8", 1/2" O.D. tube Push-in Fittings

1/8, 1/4, 3/8, 1/2 NPTF Threaded Ports

4, 6, 8, 10mm O.D. tube Push-in Fittings

Inlet Port:

1/8, 1/4, 3/8, 1/2 NPTF Thread

1/8, 1/4, 3/8, 1/2 ISO G Thread

Tubing Types:

Nylon 11 or 12, polyurethane (95 durometer or above)

LDPE (Low Density Polyethylene)

Materials

Nickel plated brass body

Nickel plated brass collet

Plastic sealing washer

Nitrile and polyurethane elastomeric parts

Zinc plated brass banjo bolt



Function Fittings and Flow Controls

Dimensions in Inches (mm)

Pressure Reducing Fitting - 124GB

O.D. Tube

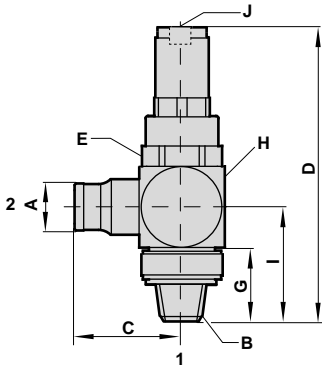

Part Number	A O/D Tube	B NPT Thread	C	D (max)	E A/F	G	H SQ A/F	I	J A/F
12 4GB 0218	5/32	1/8	0.89 (23)	2.87 (73)	0.67 (17)	—	0.63 (16)	0.78 (20)	0.20 (5)
12 4GB 0418	1/4	1/8	0.91 (23)	2.87 (73)	0.67 (17)	—	0.63 (16)	0.78 (20)	0.20 (5)
12 4GB 0428	1/4	1/4	1.0 (25)	3.10 (79)	0.67 (17)	0.64 (16)	0.79 (20)	1.02 (26)	0.20 (5)
12 4GB 0528	5/16	1/4	1.03 (26)	3.10 (79)	0.67 (17)	0.64 (16)	0.79 (20)	1.02 (26)	0.20 (5)
12 4GB 0538	5/16	3/8	1.11 (28)	3.35 (85)	0.87 (22)	0.69 (18)	0.94 (24)	1.14 (29)	0.34 (6)
12 4GB 0638	3/8	3/8	1.29 (33)	3.35 (85)	0.87 (22)	0.69 (18)	0.94 (24)	1.14 (29)	0.34 (6)
12 4GB 0748	1/2	1/2	1.56 (40)	3.54 (90)	1.06 (27)	—	1.18 (30)	1.38 (35)	0.24 (6)

- 1) Inlet Port
- 2) Outlet Port

Note: For mounting in ports 2 & 4 of a pneumatic directional control valve

Pressure Reducing Fitting - 124GB

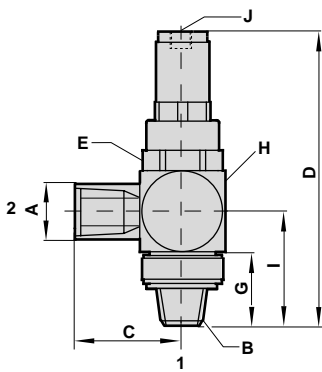

Part Number	A NPT Thread	B NPT Thread	C	D (max)	E A/F	G	H SQ A/F	I	J A/F
12 4GB 1818	1/8	1/8	0.83 (21)	2.87 (73)	0.67 (17)	—	0.64 (16)	0.78 (20)	0.20 (5)
12 4GB 2828	1/4	1/4	1.14 (29)	3.10 (79)	0.67 (17)	0.64 (16)	0.79 (20)	1.02 (26)	0.20 (5)
12 4GB 3838	3/8	3/8	1.20 (31)	3.35 (85)	0.87 (22)	0.69 (18)	0.94 (24)	1.14 (29)	0.24 (6)
12 4GB 4848	1/2	1/2	1.54 (39)	3.54 (90)	1.06 (27)	—	1.18 (30)	0.98 (35)	0.24 (6)

- 1) Inlet Port
- 2) Outlet Port

Note: For mounting in ports 2 & 4 of a pneumatic directional control valve

Pressure Reducing Fitting - 102GB

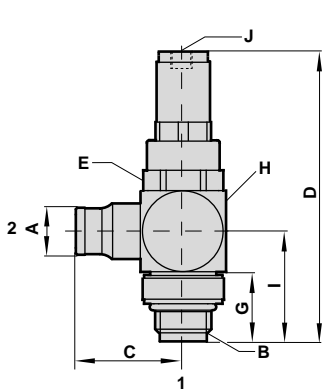

Part Number	A O/D tube	B ISO G Thread	C	D (max)	E A/F	G	H SQ A/F	I	J A/F
10 2GB 0418	4	1/8	0.89 (22)	2.87 (73)	0.67 (17)	0.25 (6)	0.64 (16)	0.78 (20)	0.20 (5)
10 2GB 0628	6	1/4	1.00 (25)	3.54 (90)	0.67 (17)	0.41 (11)	0.79 (20)	1.02 (26)	0.20 (5)
10 2GB 0828	8	1/4	1.03 (26)	3.54 (90)	0.67 (17)	0.41 (11)	0.79 (20)	1.02 (26)	0.20 (5)
10 2GB 0838	8	3/8	1.11 (28)	3.78 (96)	0.87 (22)	0.43 (11)	0.94 (24)	1.14 (29)	0.24 (6)
10 2GB 1038	10	3/8	1.29 (33)	3.78 (96)	0.87 (22)	0.43 (11)	0.94 (24)	1.14 (29)	0.24 (6)
Part Number	A ISO G Thread	B ISO G Thread	C	D (max)	E A/F	G	H SQ A/F	I	J A/F
10 2GB 1818	1/8	1/8	0.69 (18)	2.87 (73)	0.67 (17)	0.25 (6)	0.64 (16)	0.78 (20)	0.20 (5)
10 2GB 2828	1/4	1/4	0.96 (25)	3.19 (81)	0.37 (17)	0.41 (11)	0.79 (20)	1.02 (26)	0.20 (5)
10 2GB 3838	3/8	3/8	1.06 (27)	3.46 (88)	0.87 (22)	0.43 (11)	0.94 (24)	1.14 (29)	0.24 (6)
10 2GB 4848	1/2	1/2	1.34 (34)	3.50 (89)	1.06 (27)	0.37 (10)	1.18 (30)	1.42 (36)	0.24 (6)

- 1) Inlet Port
- 2) Outlet Port

Note: For mounting in ports 2 & 4 of a pneumatic directional control valve



Flow characteristics at primary pressure of 100 psi (7 bar)
Inch and Metric Versions

1/8 Pipe

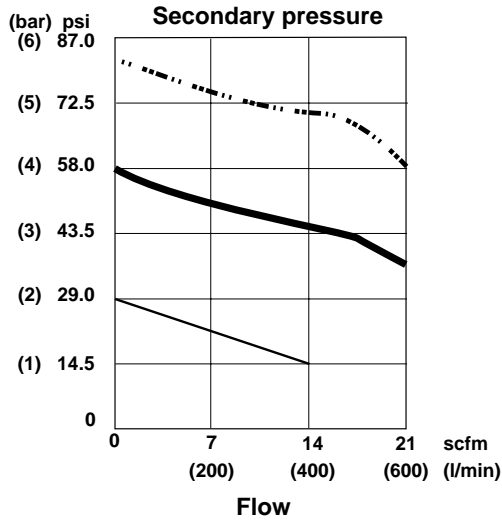

1/4 Pipe

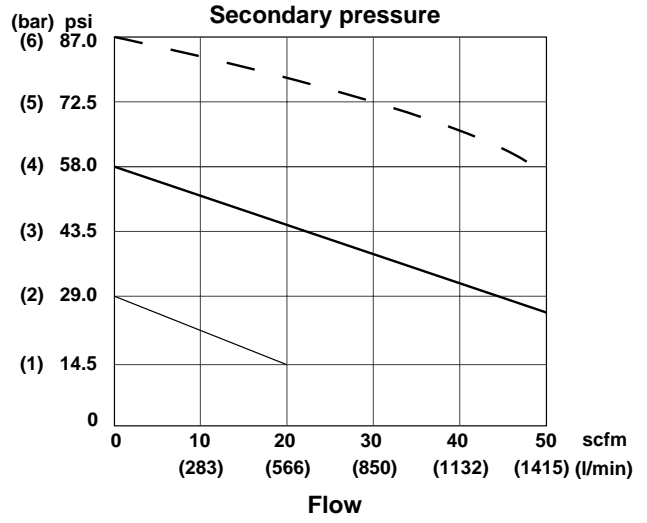

3/8 and 1/2 Pipe

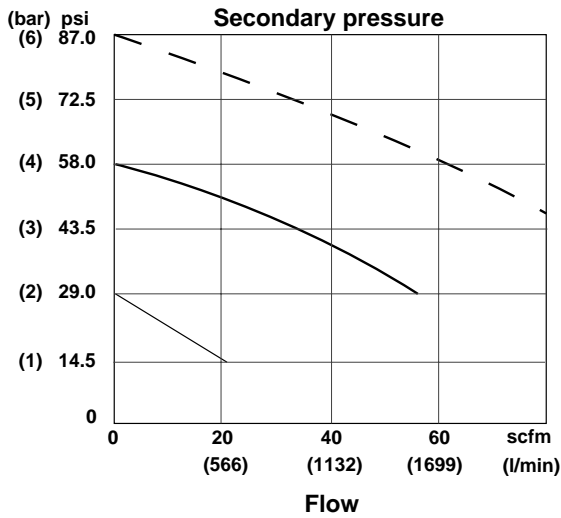

Pilot Operated Check Valve Inch and Metric

- Compact size
- Easy tube insertion for rapid assembly of pneumatic circuits
- Positive tube retention
- Safer pneumatic systems
- Push-in and threaded ports

Technical Data

Fluid: Compressed air, nitrogen, inert and non-combustible gases compatible with materials of construction.

Note: For other types of fluids or compressed gases, please consult factory.

Operating Pressure:
15-150 psi (1 - 10 bar)

Operating Temperature:
0° to 175°F (-20° to +80°C)

Inlet Port:
1/4", 3/8", 1/2" O.D. tube Push-in Fittings
1/8, 1/4, 3/8, 1/2 NPTF Threaded Ports
6, 8, 10, 12mm O.D. tube Push-in Fittings

Outlet Port:
1/8, 1/4, 3/8, 1/2 NPTF Thread*
1/4, 3/8, 1/2 ISO G Thread

* Male NPTF threads (port 2) should be assembled hand tight and then wrenched no more than 1/2 to 3/4 turn.

NPTF Thread (male)	Maximum Tightening Torque ft lbs (Nm)
1/8	5 (7)
1/4	11 (15)
3/8	14 (20)
1/2	14 (20)

Signal Port:
10-32 UNF on NPT ported models
M5 on metric models

Tube Sizes
1/4", 3/8", 1/2" O/D
6, 8, 10, 12mm O/D

Tubing Types:
Nylon 11 or 12, polyurethane (95 durometer or above), and LDPE (Low Density Polyethylene)

Materials

Nickel plated brass body
Nickel plated brass collet
Plastic sealing washer (ISO G)
Nitrile and polyurethane elastomeric parts
Zinc plated brass banjo bolts



Ordering Information

To order, quote appropriate product number from the tables on the following pages.

Product numbering system is designed to make identification and selection simple:

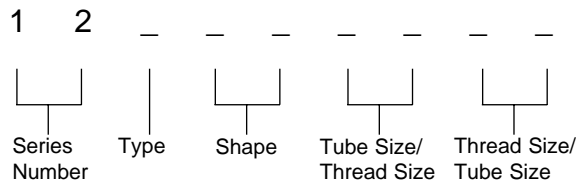

124GA

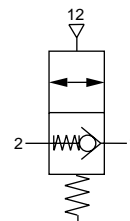

124GA

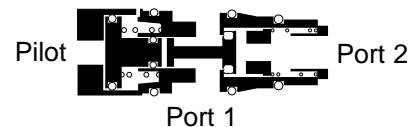

Flow Rates (scfm)				
Port Size	1/8	1/4	3/8	1/2
From 2 to 1 P12 = 88 psi	10.2	23.9	40.8	67.4
From 1 to 2 P12 = 0 psi	4.5	21.8	41.3	66.7



Pilot Operated Check Valve - 124GA

Inch O.D. Tube x NPTF thread

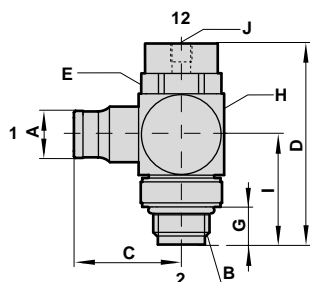

Product Number	A O.D. Tube	B NPT Thread	C	D	E A/F	G	H SQ A/F	I	J
12 4GA 0418	1/4"	1/8	0.91 (23)	1.61 (41)	0.51 (13)	0.48 (12)	0.63 (16)	0.78 (20)	10-32 UNF
12 4GA 0428	1/4"	1/4	0.99 (25)	1.89 (48)	0.67 (17)	0.64 (16)	0.79 (20)	1.02 (26)	10-32 UNF
12 4GA 0638	3/8"	3/8	1.29 (33)	2.16 (55)	0.87 (22)	0.69 (18)	0.94 (24)	1.14 (29)	10-32 UNF
12 4GA 0748	1/2"	1/2	1.56 (40)	2.58 (66)	1.06 (27)	0.87 (22)	1.18 (30)	1.42 (36)	10-32 UNF

- 1) Inlet Port
- 2) Outlet Port
- 12) Signal Port

Note: For mounting in pairs on a cylinder

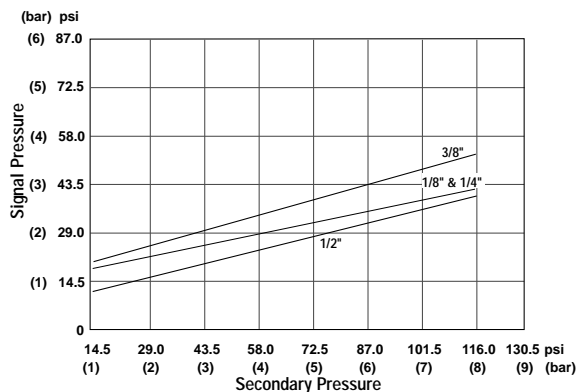

Pilot Operated Check Valve - 124GA

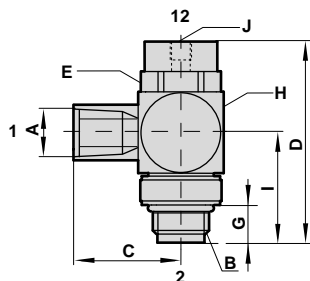

Product Number	A NPT Thread	B NPT Thread	C	D	E	G A/F	HSQ A/F	I	J
12 4GA 1818	1/8	1/8	0.87 (22)	1.61 (41)	0.51 (13)	0.48 (12)	0.63 (16)	0.78 (20)	10-32 UNF
12 4GA 2828	1/4	1/4	1.14 (29)	1.89 (48)	0.67 (17)	0.64 (16)	0.79 (20)	1.02 (26)	10-32 UNF
12 4GA 3838	3/8	3/8	1.20 (31)	2.17 (55)	0.87 (22)	0.69 (18)	0.94 (24)	1.14 (29)	10-32 UNF
12 4GA 4848	1/2	1/2	1.54 (39)	2.58 (66)	1.06 (27)	0.87 (22)	1.18 (30)	1.42 (36)	10-32 UNF

- 1) Inlet Port
- 2) Outlet Port
- 12) Signal Port

Note: For mounting in pairs on a cylinder

Pilot Operated Check Valve - 102GA

mm O.D. tube x ISO G thread

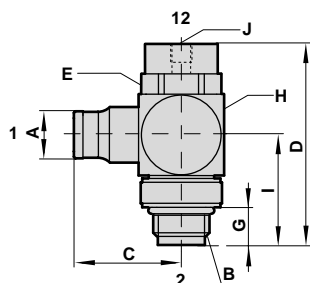

Product Number	A O/D tube	B ISO G Thread	C	D	E A/F	G	HSQ A/F	I	J
10 2GA 0628	6	1/4	0.99 (25)	1.87 (48)	0.67 (17)	0.41 (11)	0.79 (20)	1.02 (26)	M5
10 2GA 0828	8	1/4	1.03 (26)	1.87 (48)	0.67 (17)	0.41 (11)	0.79 (20)	1.02 (26)	M5
10 2GA 0838	8	3/8	1.11 (28)	2.15 (55)	0.87 (22)	0.43 (11)	0.94 (24)	1.14 (29)	M5
10 2GA 1038	10	3/8	1.29 (33)	2.15 (55)	0.87 (22)	0.43 (11)	0.94 (24)	1.14 (29)	M5
10 2GA 1248	12	1/2	1.56 (40)	2.56 (65)	1.06 (27)	0.50 (13)	1.18 (30)	1.42 (36)	M5

- 1) Inlet Port
- 2) Outlet Port
- 12) Signal Port

Note: For mounting in pairs on a cylinder

- Compact units
- Easy tube insertion for rapid assembly of pneumatic circuits
- Positive tube retention
- Simplifies pneumatic systems
- Eliminates need for electrical reed switches
- Exhausts on signal side (port 2)



Technical Data

Fluid: Compressed air, nitrogen, inert and non-combustible gases compatible with materials of construction.

Note: For other types of fluids or compressed gases, please consult factory.

Operating Pressure:

Cylinder pressure (Pc)	145 psi (10 bar) max
Sensor supply pressure	43 to 145 psi (3 - 10 bar)
Sensor switch pressure	14.5 psi (1.0 bar) typical

Operating Temperature:

0° to 175°F (-20° to +80°C)

Body Ports

5/32" O.D. tube Push-in
 4mm O.D. tube Push-in
 1/8, 1/4 NPTF Banjo Bolt
 1/8, 1/4 ISO G Banjo Bolt

Tube Sizes

5/32" O/D
 4mm O/D

Tubing Types:

Nylon 11 or 12, polyurethane (95 durometer or above) and LPDE (Low Density Polyethylene)

Materials

Body, swivel fitting and collet: Nickel plated brass

O-ring: Silicone free Nitrile

Sealing washer (parallel male threads): Thermoplastic

Tubing: Nylon 11 or 12, Polyurethane (95 durometer or above) and LDPE (Low Density Polyethylene).

Note: Lower durometer polyurethane may be used, however, an internal tube support is required to prevent internal collapse of the tube wall.

Ordering Information

To order, quote appropriate product number from the tables on the following pages.

Product numbering system is designed to make identification and selection simple:

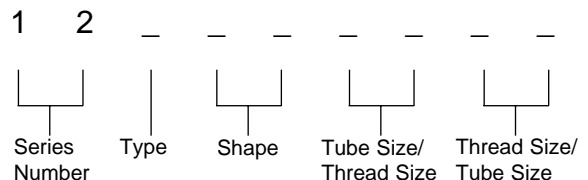

124GD

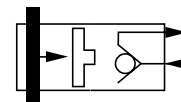

124GD

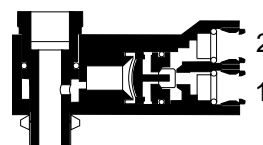



Pressure Sensor Fitting- 124GD

Inch O.D. tube x NPTF Banjo Bolt

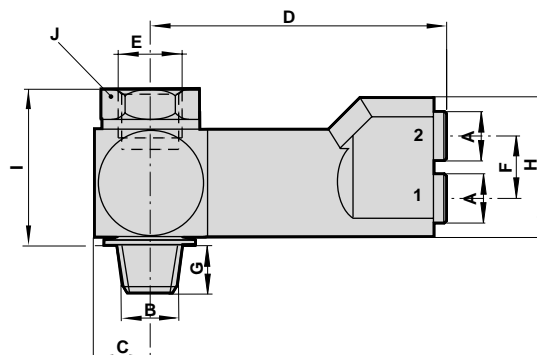

Product Number	A Tube O/D	B NPT Thread	C	D	E NPT Thread	F	G	H	I	J A/F
12 4GD 0218	5/32"	1/8	0.35 (9)	1.77 (45)	1/8	0.39 (10)	0.39 (10)	0.83 (21)	1.12 (29)	9/16"
12 4GD 0228	5/32"	1/4	0.43 (11)	1.85 (47)	1/4	0.39 (10)	0.56 (14)	0.83 (21)	1.33 (34)	3/4"

This sensor fitting produces an end of stroke signal when exhaust back pressure in a cylinder decays below a set value. It should be mounted directly on the cylinder and can be used with a flow control device mounted into the top port.

It is recommended that the sensor supply pressure to port 1 be the same as the nominal working pressure of the cylinder.

Pressure Sensor Fitting- 102GD

mm O.D. tube x ISO G Banjo Bolt

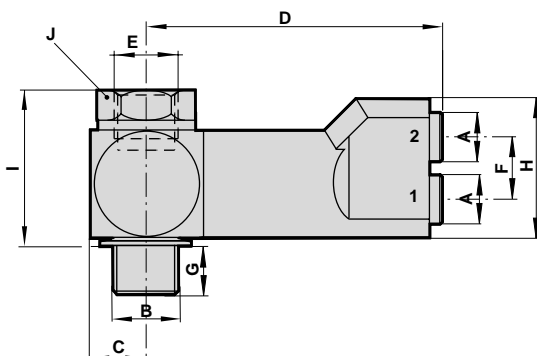

Product Number	A Tube O/D	B ISO G Thrd	C	D	E ISO G thread	F	G	H	I	J A/F
10 2GD 0418	4	1/8	0.35 (9)	1.77 (45)	1/8	0.39 (10)	0.24 (6)	0.83 (21)	0.98 (25)	0.59 (15)
10 2GD 0428	4	1/4	0.43 (11)	1.85 (47)	1/4	0.39 (10)	0.28 (7)	0.83 (21)	1.14 (29)	0.75 (19)

This sensor fitting produces an end of stroke signal when exhaust back pressure in a cylinder decays below a set value. It should be mounted directly on the cylinder and can be used with a flow control device mounted into the top port.

It is recommended that the sensor supply pressure to port 1 be the same as the nominal working pressure of the cylinder.

- Enables air to be exhausted quickly from air reservoirs and cylinders
- Allows higher cylinder speeds to be achieved
- Simple, compact design and construction
- Reliable operation



Technical Data

Fluid:

Compressed air, filtered, lubricated and non-lubricated

Operation:

Diaphragm

Mounting:

Line mounted

Port Size:

Female Thread

(Inlet, outlet and exhaust ports)

NPT		ISO G	
1/8 NPT	T70A1800	G1/8	T70C1800
1/4 NPT	T70A2800	G1/4	T70C2800
3/8 NPT	T70A3800	G3/8	T70C3800
1/2 NPT	T70A4800	G1/2	T70C4800
3/4 NPT	C/511*		

* Note: C/511 has 1/2" NPT inlet port and 3/4" NPT outlet ports.

Operating Pressure:

7 - 145 psi (0.5 - 10 bar)

Operating Temperature:

0° to 175°F (-20*** to +80°C)

***Consult our Technical Service for use below 35°F (2°C)

Materials

Zinc or aluminum alloy body and cover, nitrile seals (PU seal on C/511).

Ordering Information

To order, quote model number from page FIT-3-21, e.g. T70A2800 for the NPT ported version. This range replaces the C/510 and S/510 models.

Quick Exhaust Valve

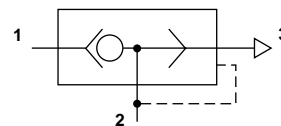

Typical Fill and Exhaust Times (seconds)

Model	Port size	Volume	Fill time	Exhaust time
T70A1800	1/8" NPT	150 cc	0.036	0.021
T70A2800	1/4" NPT	150 cc	0.023	0.017
T70A3800	3/8" NPT	1500 cc	0.110	0.080
T70A4800	1/2" NPT	15,000 cc	0.460	0.480
C/511	3/4" NPT	15,000 cc	0.480	0.250

Note: Fill time is 0 to 80 psig (0 to 5.5 bar), and exhaust time is 101 to 20 psig (7.0 to 1.4 bar)



General Information

Model NPT	Model ISO G	Inlet port	Outlet port	Exhaust port	Cv Flow Factor Direction 1 - 2*	Cv Flow Factor Direction 2 - 3	Weight oz (kg)	Repair kit (seals only)
T70A 1800	T70C 1800	1/8	1/8	1/8	0.9	1.8	5.3 (0.15)	T70C1800K0
T70A 2800	T70C 2800	1/4	1/4	1/4	1.9	2.5	4.6 (0.13)	T70C2800K0
T70A 3800	T70C 3800	3/8	3/8	3/8	3.8	5.5	7.4 (0.21)	T70C3800K0
T70A 4800	T70C 4800	1/2	1/2	1/2	5.3	5.9	6.7 (0.19)	T70C4800K0
C/511	S/511	1/2	3/4	3/4	**1.9/5.1	10.8	11.0 (0.31)	QS/511/00

* Flow factor measured at 87 psi (6 bar) (inlet) guideline direction

** Alternative Cv shown for 14.5 psi (1 bar). For T70 Series, Cv approximately the same as at 6 bar.

NPT threads per ANSI B1.20.1

Quick Exhaust Valve

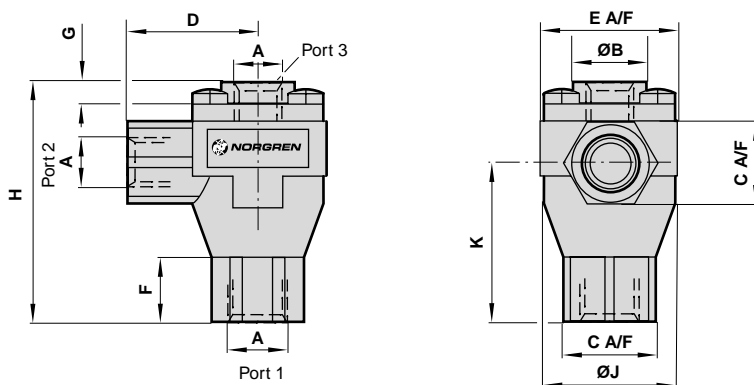

Model	T70A1800	T70C1800	T70A2800	T70C2800	T70A3800	T70C3800	T70A4800	T70C4800	C/511*
A	1/8 NPT	G1/8	1/4 NPT	G1/4	3/8 NPT	G3/8	1/2 NPT	G1/2	1/20 - 3/4
ØB	0.75 (19)	0.75 (19)	0.75 (19)	0.75 (19)	1.18 (30)	1.18 (30)	1.18 (30)	1.18 (30)	—
C A/F	0.75 (19)	0.75 (19)	0.75 (19)	0.75 (19)	1.18 (30)	1.18 (30)	1.18 (30)	1.18 (30)	—
D	1.10 (28)	1.10 (28)	1.10 (28)	1.10 (28)	1.57 (40)	1.57 (40)	1.57 (40)	1.57 (40)	2.0 (50)
E A/F	1.18 (30)	1.18 (30)	1.18 (30)	1.18 (30)	1.81 (46)	1.81 (46)	1.81 (46)	1.81 (46)	1.87 (47.5)
F	0.60 (15.3)	0.60 (15.3)	0.60 (15.3)	0.60 (15.3)	0.61 (15.5)	0.61 (15.5)	0.61 (15.5)	0.61 (15.5)	—
G	0.14 (3.5)	0.14 (3.5)	0.14 (3.5)	0.14 (3.5)	0.16 (4)	0.16 (4)	0.16 (4)	0.16 (4)	—
H	2.09 (53)	2.09 (53)	2.09 (53)	2.09 (53)	2.89 (73.5)	2.89 (73.5)	2.89 (73.5)	2.89 (73.5)	3.38 (86)
ØJ	1.14 (29)	1.14 (29)	1.14 (29)	1.14 (29)	1.81 (46)	1.81 (46)	1.81 (46)	1.81 (46)	—
K	1.40 (35.5)	1.40 (35.5)	1.40 (35.5)	1.40 (35.5)	1.89 (48)	1.89 (48)	1.89 (48)	1.89 (48)	2.72 (69)

* Note the shape of the C/511 is different. Consult our technical department for the exact specifications.

T70 Series Flowrate

Choked flow versus inlet pressure
(1 - 2) + (2 - 3)

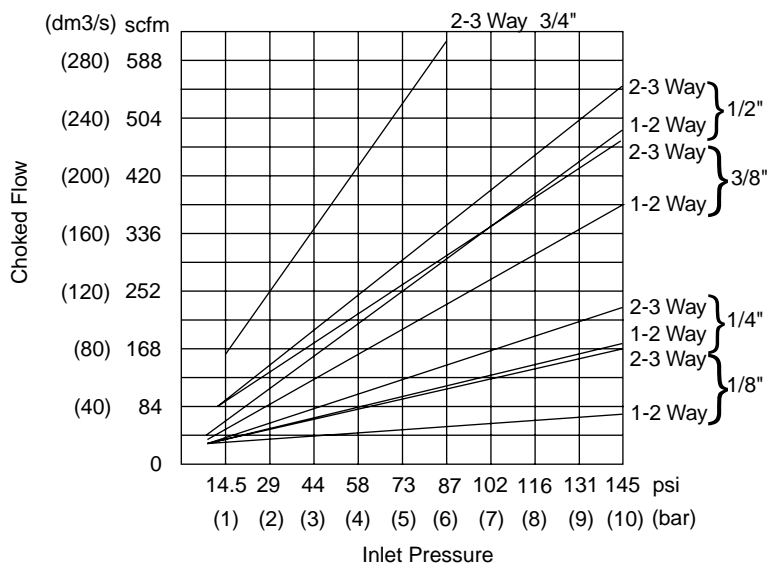

- Allow two independent signal sources to be connected to a common pilot line
- Can be used to perform an 'OR' logic function
- Selects the highest of two applied pressures
- Can be combined to operate from three or more sources
- Valves can be ganged together



Technical Data

Fluid:

Compressed air, filtered, lubricated and non-lubricated, inert gases

Operation:

Shuttle valve

Mounting:

Through holes in valve body

Port Size:

Female Thread

NPT	ISO G
1/8 NPT T65A1800	G1/8 T65C1800
1/4 NPT T65A2800	G1/4 T65C2800

Operating Pressure:

10 to 145 psi (0.7 - 10 bar)

Operating Temperature:

0° to 175°F (-20°* to +80°C)

*Consult our Technical Service for use below 35°F (2°C)

Materials

Body: Zinc

Ball: Nitrile

Seat: Brass

Ordering Information

To order, quote model number from table on page. FIT-3-19, e.g. T65A1800 for the 1/8" NPT.

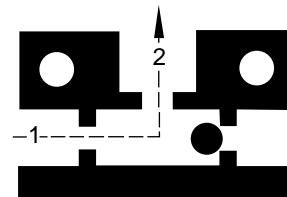
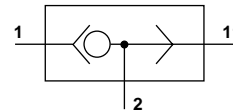



Product Number		Port Size	Flow Factor Cv	Weight oz. (kg)
NPT	ISO G			
T65A1800	T65C1800	1/8	0.42	1.9 (.055)
T65A2800	T65C2800	1/4	0.64	4.6 (.130)

NPT according to ANSI B1.20.1

Shuttle Valve

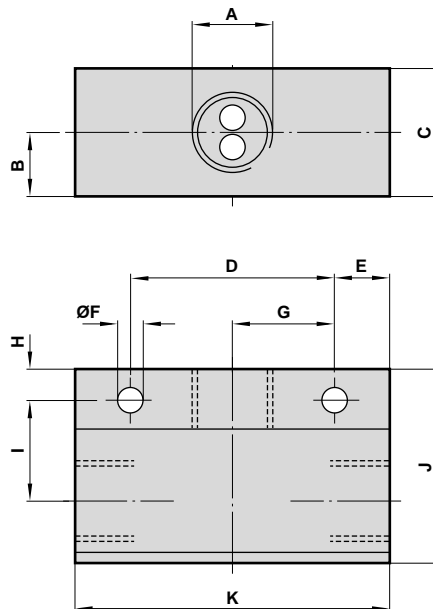

Model	A	B	C	D	E	F	G	H	I	J	K
T65A 1800	1/8 NPT	0.30 (8)	0.59 (15)	0.79 (20)	0.3 (8)	0.21 (5)	0.39 (10)	0.24 (6)	0.39 (10)	1.00 (25)	1.42 (36)
T65C 1800	G1/8	0.30 (8)	0.59 (15)	0.79 (20)	0.3 (8)	0.21 (5)	0.39 (10)	0.24 (6)	0.39 (10)	1.00 (25)	1.42 (36)
T65A 2800	NPT1/4	0.39 (10)	0.79 (20)	0.98 (25)	0.49 (13)	0.21 (5)	0.49 (13)	0.31 (8)	0.47 (12)	1.18 (30)	2.00 (50)
T65C 2800	G1/4	0.39 (10)	0.79 (20)	0.98 (25)	0.49 (13)	0.21 (5)	0.49 (13)	0.31 (8)	0.47 (12)	1.18 (30)	2.00 (50)

NPT according to ANSI B1.20.1

G according to BS 2779/ISO 228/1

FleetFit Vehicle Push-In Fittings



FleetFit ShapesFIT-4-2
FleetFit SpecificationsFIT-4-3
FleetFit DimensionsFIT-4-5

- **Simple tube connection and disconnection - no tools required**
- **Fewer component parts - Internally machined form in body to secure collet reduces number of potential leak paths**
- **Corrosion resistant**
- **Easy identification - All collets marked with tube size**
- **Total fittings system solution**
- **Reduced assembly & maintenance times provide time/labor savings**
- **Greater reliability and reduced testing**
- **Ease of tube insertion in areas of restricted access**



Technical Data

Operating Medium:

Compressed air

Maximum Working Pressure:

0 to 150 psi (0 to 10 bar)

Working Temperature:

-40°F to 220°F (-40°C to 100°C)

Materials:

Body (Straights), Tube support, Collet - Brass BS 2874 CZ 121
 Body (Elbows, Tees) - Brass BS 2874 CZ 122
 'O' Ring - Buna N (Low Nitrile).
 Thread Sealant - Precoat 5

Tubing:

Tube should be to SAE J844 (Imperial)
 or DIN 74324 (Metric)

Standards & Legislation:

Fittings and Tubing Comply to Department Of Transport
 Federal Motor Vehicle Safety Standard, (DOT FMVSS 106)
 (Mandatory requirements for Inch tube fittings in U.S.A.)
 Society for Automotive Engineers (SAE) J1131 (Inch tube and
 fittings) and meet DIN 74324 and German TÜV requirements
 (Metric Tube and Fittings)

Applications:

As a connector on all air brake systems at locations other than
 between chassis frame and axle or between towed and towing
 vehicle.

Also as a connector on all air operated systems as applicable
 to suspension, steering, engine, transmission and auxiliary
 mechanisms.

Swivel Fittings:

The swivel feature should be used for positioning purposes
 only and should not be used as a rotating joint.

Ordering Information

To order, quote the appropriate product
 number from the tables on the following pages.

Options

Tube Sizes - Imperial and Metric

For metric tube sizes and tube sizes below 1/4"
 and 6mm please consult our technical services
 department.

Standard Thread sizes - NPT, Metric, BSP
 Non-standard thread sizes are also included
 (e.g. UNF)

Note: Part numbers in **bold** are generally
 available from stock. For specialised shapes
 and thread forms contact Norgren Detroit's
 Technical Support.

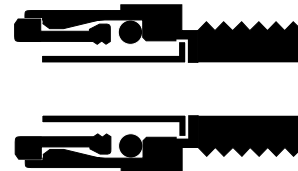



Typical Layout & Dimensions

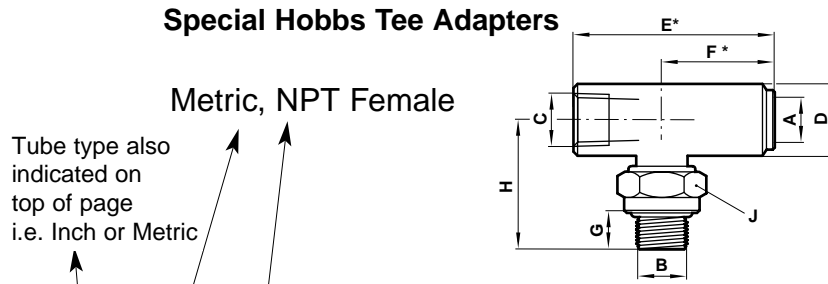

* Similar dimensions given in individual tables refer to the collet being in the 'IN' position.

A Tube O.D.	B Thread	C NPT Female	Product Number	ØD	E	F	G	H	J A/F
3/8"	M16 x 1.5	1/4"	95 4621 03	0.75 (19.0)	2.07 (52.5)	1.12 (28.5)	0.41 (10.5)	1.32 (33.5)	1.06 (27)
3/8"	M22 x 1.5	1/4"	95 4621 02	0.87 (22.0)	2.20 (56.0)	3.46 (32.0)	0.51 (13.0)	1.70 (43.0)	1.06 (27)
1/2"	M22 x 1.5	1/4"	95 4621 01	0.87 (22.0)	2.36 (60.0)	1.42 (36.0)	0.51 (13.0)	1.70 (43.0)	1.06 (27)

Installation

Tube Connection / Disconnection

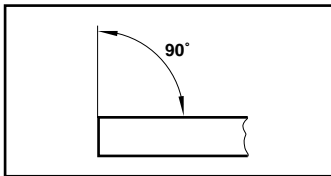

1. Ensure that the end of the tube is cut square and is free from burrs.

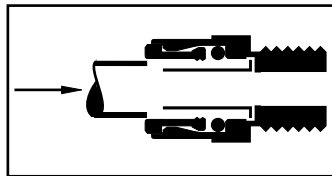

2. Push the tube through the collet into the fitting.

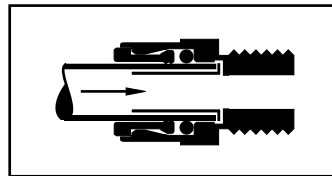

3. Continue pushing the tube through the 'O' ring until it bottoms on the tube stop. Then pull back on the tube to reinforce the collet teeth gripping action.

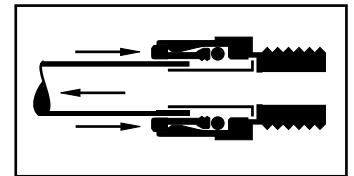

4. To disconnect - First ensure there is no air present. Push the tube into the fitting until it bottoms on the tube stop. Then hold down the collet and withdraw the tube.

Component Functions

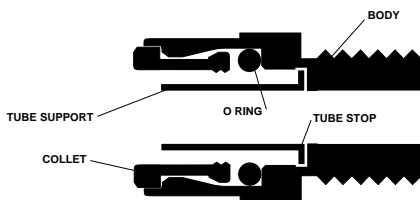

- Body** - The body has an internally machined form to secure the collet(s), "O" ring(s) and Tube support(s). It also has internal & externally machined thread form(s) for connection to ports where applicable.
- Collet** - The purpose of the collet is to grip the tube and ensure it is retained by the fitting at all times.
- "O" Ring** - The "O" ring is to ensure adequate interference between the tube & fitting body therefore providing a pneumatic seal at all times.
- Tube Support** - The tube support prevents the tube collapsing during extreme tensile loading conditions. Such conditions are only encountered during performance testing and far exceed those experienced during normal use.



FleetFit Vehicle Shapes



Male Connectors
NPT and Metric p. FIT-4-5
BSP taper p. FIT-4-6
UNF / SAE 45° Flare
p. FIT 4-6.



Female Connectors
NPT p. FIT-4-6
UNF p. FIT-4-7



Straight Unions
Inch p. FIT-4-7



Straight Bulkhead Unions
Metric p. FIT-4-7



Female Bulkhead
Connectors
NPT Female, UNF
p. FIT-4-7



Male Bulkhead
Connectors
Metric/metric,
BSPT/Metric p. FIT-4-8

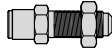

Straight Bulkhead Adapters
UNF / SAE 45° Flare
p. FIT-4-8



Plug (thermoplastic)
p. FIT-4-9



Male Elbows
NPT p. FIT-4-9
BSP Taper p. FIT-4-10.



Male Hobbs Elbows
Metric p. FIT-4-10



Male Swivel Elbow
NPT p. FIT-4-11



45° Male Elbow
NPT p. FIT-4-11



45° Male Hobbs Elbow
Metric and NPT
p. FIT-4-11



90° and 45° Female Elbow
NPT
p. FIT-4-12



Union Elbows
p. FIT-4-12



Union Bulkhead Elbows
Metric P. FIT-4-12
NPT Female, UNF
p. FIT-4-13

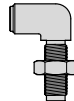

Bulkhead Elbow Adapters
UNF/SAE 45° Flare
p. FIT-4-13

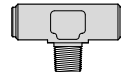

Male Branch Tees
NPT p. FIT-4-13
BSP Taper p. FIT-4-14

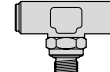

Hobbs Tee Adapters
Metric p. FIT-4-14

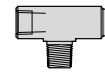

Special Tee Adapters
NPT, NPT Female
p. FIT-4-14

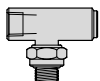

Universal Hobbs Tee
Adapters
Metric, NPT Female
p. FIT-4-15

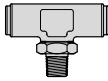

Male Swivel Branch Tees
NPT p. FIT-4-15

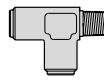

Male Run Tees
NPT p. FIT-4-16
NPT, NPT Female
p. FIT-4-17
metric p. FIT-4-15

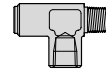

Side Tee Adapters
NPT, NPT Female
p. FIT-4-16

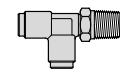

Side Tee Adapters NPT,
NPT Female
p. FIT-4-17



Special Tee Adapters
NPT Female, NPT
p. FIT-4-17

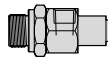

Special Hobbs Side Tee
Adapters Metric, NPT
Female p. FIT-4-17



Special 90° Tees
NPT p. FIT-4-18



90° Fixed Tees
p. FIT-4-(18-19)



Special 90° Bulkhead Tees
NPT Female
p. FIT-4-18



Special Bracketed Tee
Adapter, NPT Female
p. FIT-4-19



Union Tee's
NPT Female
p. FIT-4-20



Special Bracketed
Reducing Tee Connectors
p. FIT-4-21



Special Bulkhead Tees
UNF/SAE 45° Flare
p. FIT-4-21

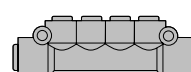

6 Port Manifold
p. FIT-4-21



Special Bulkhead Tees
UNF/SAE 45° Flare
p. FIT-4-13

FleetFit Vehicle Push-In Fittings

Dimensions in Inches (mm)



Male Connectors NPT

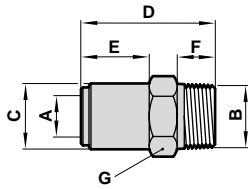

Part numbers ending with "V" have Viton seals.
*Special short 1/16" PTF-SAE short thread
5/32" fittings have a Pneufit style body and collet

SAE 630102

A Tube O.D.	B NPT	Product Number	ØC	D	E	F	G A/F
5/32"	1/16"	70 4542 02V	0.98 (25.0)	0.43 (11.0)	-	0.31 (8.0)	11/32"
5/32"	1/8"	70 4530 02V	0.30 (7.5)	0.89 (22.7)	-	0.37 (9.5)	7/16"
3/16"	1/8"	95 4530 03	0.46 (11.7)	1.02 (25.8)	0.43 (10.8)	0.37 (9.5)	1/2"
1/4"	1/8"	95 4530 04	0.50 (12.7)	1.04 (26.3)	0.43 (10.8)	0.37 (9.5)	1/2"
1/4"	1/4"	95 4530 10	0.50 (12.7)	1.17 (29.8)	0.37 (9.3)	0.56 (14.3)	9/16"
1/4"	3/8"	95 4530 18	0.50 (12.7)	1.20 (30.5)	0.31 (8.0)	0.56 (14.3)	11/16"
3/8"	1/8"	95 4530 06	0.65 (16.5)	1.32 (33.6)	0.67 (17.1)	0.37 (9.5)	11/16"
3/8"	1/4"	95 4530 12	0.66 (16.5)	1.48 (37.6)	0.63 (16.1)	0.56 (14.3)	11/16"
3/8"	3/8"	95 4530 20	0.66 (16.5)	1.42 (36.1)	0.54 (13.6)	0.56 (14.3)	11/16"
3/8"	1/2"	95 4530 29	0.66 (16.5)	1.46 (37.1)	0.36 (9.1)	0.75 (19.0)	7/8"
1/2"	1/4"	95 4530 13	0.79 (20.0)	1.68 (42.6)	0.75 (19.1)	0.56 (14.3)	7/8"
1/2"	3/8"	95 4530 21	0.79 (20.0)	1.64 (41.6)	0.71 (18.1)	0.56 (14.3)	7/8"
1/2"	1/2"	95 4530 30	0.79 (20.0)	1.72 (43.6)	0.61 (15.6)	0.75 (19.0)	7/8"
5/8"	3/8"	95 4530 22	0.98 (25.0)	1.87 (47.5)	0.89 (22.5)	0.56 (14.3)	1-1/16"
5/8"	1/2"	95 4530 31	0.98 (25.0)	2.12 (53.5)	0.93 (23.5)	0.75 (19.0)	1-1/16"
3/4"	1/2"	95 4530 49	1.00 (25.5)	2.11 (53.5)	0.89 (22.5)	0.75 (19.0)	1-3/16"

Male Connectors Metric

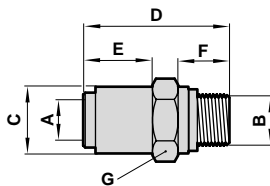

A Tube O.D.	B Thread Thread	Product Number	ØC	D	E	F	A/F
1/4"	M10 x 1.0	94 4666 31	0.51 (13.0)	1.12 (28.5)	0.53 (13.5)	0.39 (10.0)	0.55 (14)
1/4"	M12 x 1.5	94 4666 33	0.51 (13.0)	1.12 (30.5)	0.53 (11.5)	0.39 (12.0)	0.67 (17)
1/4"	M16 x 1.5	94 4666 35	0.51 (13.0)	1.12 (27.5)	0.53 (7.5)	0.39 (12.0)	0.87 (22)
1/4"	M22 x 1.5	94 4666 38	0.51 (13.0)	1.12 (30.5)	0.53 (5.0)	0.39 (14.5)	1.06 (27)
3/8"	M12 x 1.5	94 4666 53	0.51 (16.8)	1.12 (35.0)	0.53 (16.0)	0.39 (12.0)	0.67 (17)
3/8"	M14 x 1.5	94 4666 54	0.51 (16.8)	1.12 (35.0)	0.59 (15.0)	0.39 (12.0)	0.75 (19)
3/8"	M16 x 1.5	94 4666 55	0.67 (17.0)	1.38 (35.0)	0.59 (15.0)	0.47 (12.0)	0.87 (22)
3/8"	M22 x 1.5	94 4666 58	0.67 (17.0)	1.22 (31.0)	0.22 (5.5)	0.57 (14.5)	1.06 (27)
1/2"	M16 x 1.5	94 4666 65	0.81 (20.5)	1.54 (39.0)	0.75 (19.0)	0.47 (12.0)	0.87 (22)
1/2"	M20 x 1.5	94 4666 67	0.81 (20.5)	1.50 (38.0)	0.51 (13.0)	0.57 (14.5)	1.06 (27)
1/2"	M22 x 1.5	94 4666 68	0.81 (20.5)	1.38 (35.0)	0.37 (9.5)	0.57 (14.5)	1.06 (27)
5/8"	M22 x 1.5	94 4666 75	1.02 (26.0)	1.75 (44.5)	0.77 (19.5)	0.57 (14.5)	1.62 (27)



FleetFit Vehicle Push-In Fittings

Dimensions in Inches (mm)

Male Connectors BSP Taper

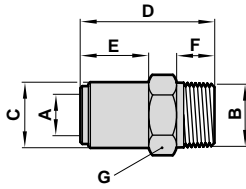

A Tube O.D.	B BSP Taper	Product Number	ØC	D	E	F	G A/F
1/4"	1/8"	94 4530 04	0.50 (12.7)	1.04 (26.3)	0.41 (10.3)	0.37 (9.5)	0.51 (13)
1/4"	1/4"	94 4530 10	0.50 (12.7)	1.06 (26.8)	0.37 (9.3)	0.44 (11.1)	0.55 (14)
3/8"	1/8"	94 4530 06	0.65 (16.5)	1.31 (33.3)	0.67 (17.1)	0.37 (9.5)	0.67 (17)
3/8"	1/4"	94 4530 12	0.79 (20)	1.55 (39.3)	0.75 (19.1)	0.44 (11.1)	0.87 (22)
3/8"	3/8"	94 4530 20	0.65 (16.5)	1.35 (34.3)	0.54 (13.6)	0.50 (12.7)	0.67 (17)
3/8"	1/2"	94 4530 29	0.65 (16.5)	1.33 (33.8)	0.36 (9.1)	0.63 (15.9)	0.87 (22)
1/2"	1/4"	94 4530 13	0.79 (20)	1.55 (39.3)	0.75 (19.1)	0.44 (11.1)	0.87 (22)
1/2"	3/8"	94 4530 21	0.79 (20)	1.57 (39.8)	0.71 (18.1)	0.50 (12.7)	0.87 (22)
1/2"	1/2"	94 4530 30	0.79 (20)	1.59 (40.3)	0.61 (15.6)	0.63 (15.9)	0.87 (22)
5/8"	1/2"	94 4530 31	0.98 (25)	1.99 (50.5)	0.93 (23.5)	0.63 (15.9)	1.06 (27)

Male Connectors UNF / SAE 45° Flare

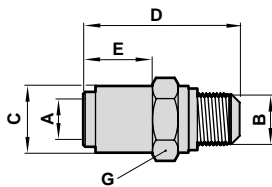

A Tube O.D.	B UNF	Product Number	C	D	E	G A/F
1/4"	7/16	94 4611 03	1.32 (33.5)	0.47 (12)	0.51 (13)	0.55 (14)
3/8"	5/8"	94 4611 01	1.59 (40.5)	0.59 (15)	0.63 (16)	0.67 (17)
1/2"	1/2"	94 4612 01	1.57 (40)	0.79 (20)	0.43 (11)	0.87 (22)
1/2"	3/4"	94 4611 02	1.85 (47)	0.63 (16)	0.75 (19)	0.87 (22)
5/8"	7/8"	94 4611 06	2.19 (55.5)	0.75 (19)	0.89 (22.5)	1.06 (27)

Extended Straight Adapters NPT Male

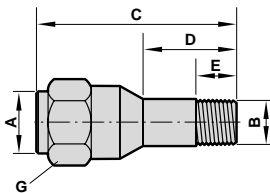

A Tube O.D.	B NPT	Product Number	ØC	D	E	G A/F
3/8"	1/8"	95 4490 06	1.85 (47.0)	0.87 (22.0)	0.37 (9.5)	11/16"

Female Connectors NPT Female

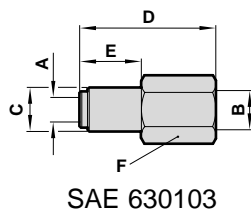

A Tube O.D.	B NPT	Product Number	ØC	D	E	F A/F
1/4"	1/8"	95 4355 04	0.51 (13)	1.31 (33.3)	0.72 (18.3)	9/16"
1/4"	1/4"	95 4355 10	0.51 (13)	1.59 (40.3)	0.72 (18.3)	11/16"
3/8"	1/8"	95 4355 06	0.67 (17)	1.50 (38)	0.91 (23)	11/16"
3/8"	1/4"	95 4355 12	0.65 (16.5)	1.74 (44.3)	0.88 (22.3)	11/16"
3/8"	3/8"	95 4355 20	0.65 (16.5)	1.78 (45.3)	0.88 (22.3)	7/8"
1/2"	1/2"	95 4355 30	0.91 (23)	2.11 (53.5)	0.96 (24.5)	11/16"



Female Connectors UNF

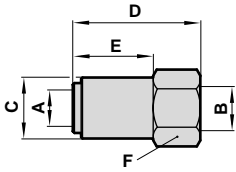

A Tube O.D.	B UNF	Product Number	Ø C	D	E	F A/F
3/8"	5/8"	94 4603 02	0.71 (18.0)	1.50 (38.0)	0.94 (24.0)	0.75 (19.0)
3/8"	3/4"	94 4603 03	0.71 (18.0)	1.69 (43.0)	1.02 (26.0)	0.94 (24.0)
1/2"	3/4"	94 4603 01	0.87 (22.0)	1.81 (46.0)	1.14 (29.0)	0.94 (24.0)
5/8"	7/8"	94 4603 04	1.04 (26.5)	2.01 (51.0)	1.20 (30.5)	1.06 (27.0)

Unions Inch

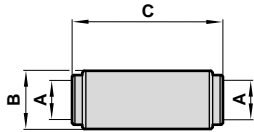

5/32" fittings have a Pneufit style body and collet

SAE 630101

A Tube O.D.	Product Number	ØB	C
5/32"	71 4503 02	0.39 (10.0)	1.18 (30.0)
3/16"	94 4503 13	0.47 (12.0)	1.36 (34.6)
1/4"	94 4503 04	0.51 (13.0)	1.40 (35.6)
3/8"	94 4503 06	0.67 (17.0)	1.74 (44.1)
1/2"	94 4503 07	0.81 (20.5)	2.01 (51.1)
5/8"	94 4503 08	1.00 (25.4)	2.42 (61.5)
3/4"	94 4503 09	1.18 (30.0)	2.48 (63.0)

Reducing Unions Inch

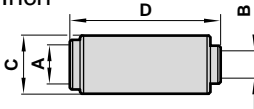

SAE 630101

A Tube O.D.	B Tube Tube	Product Number	ØC	D
3/8"	1/4"	94 4504 48	0.67 (17.0)	1.71 (43.5)
1/2"	3/8"	94 4504 64	0.81 (20.5)	1.91 (48.5)

Bulkhead Unions Metric

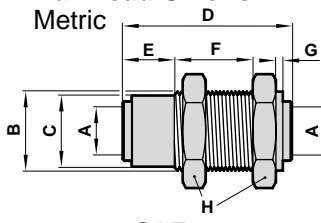

SAE 630601

A Tube O.D.	B Thread	Panel Hole ø	Product Number	Ø C	D	E	F (Max)	G (Min)	H A/F
1/4"	M15 x 1.0	0.61 (15.5)	94 4507 04	-	1.41 (35.9)	-	0.87 (22.0)	0.08 (2.0)	0.87 (22.0)
3/8"	M20 x 1.5	0.81 (20.5)	94 4507 06	0.70 (17.7)	1.75 (44.5)	0.33 (8.5)	0.87 (22.0)	0.08 (2.0)	1.06 (27.0)
1/2"	M24 x 1.5	0.97 (24.5)	94 4507 07	0.85 (21.7)	2.02 (51.4)	0.63 (16.0)	0.87 (22.0)	0.08 (2.0)	1.18 (30.0)

Female Bulkhead Connectors NPT Female, UNF

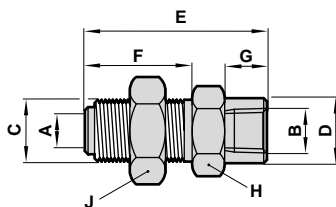

A Tube O.D.	B NPT Female	C UNF	Product Number	ØD	E	F	G	H A/F	J A/F
1/4"	1/8"	5/8"	95 4570 06	0.63 (16.0)	1.32 (33.5)	0.69 (17.5)	0.28 (7.0)	0.87 (22.0)	15/16"
1/4"	1/4"	5/8"	95 4570 01	0.79 (20.0)	1.59 (40.5)	0.73 (18.5)	0.51 (13.0)	0.87 (22.0)	15/16"
3/8"	1/4"	3/4"	95 4570 03	0.79 (20.0)	2.20 (56.0)	1.30 (33.0)	0.51 (13.0)	0.94 (24.0)	1-1/8"
3/8"	3/8"	3/4"	95 4570 04	0.79 (20.0)	2.20 (56.0)	1.30 (33.0)	0.51 (13.0)	0.94 (24.0)	1-1/8"
3/8"	1/2"	3/4"	95 4570 02	-	2.40 (61.0)	1.30 (33.0)	-	1.06 (27)	1-1/8"
1/2"	3/8"	7/8"	95 4570 05	-	1.89 (48.0)	1.50 (38.0)	-	1.06 (27)	1-5/16"
1/2"	1/2"	7/8"	95 4570 07	-	2.64 (67.0)	1.50 (38.0)	-	1.06 (27)	1-5/16"



FleetFit Vehicle Push-In Fittings

Dimensions in Inches (mm)

Male Bulkhead Connectors Metric, Metric

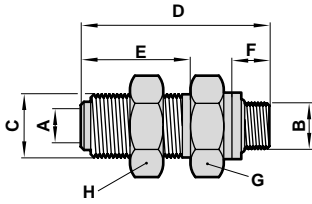

A Tube O.D.	B Thread	Panel Hole ø	C Thread	Product	D	E	F	G A/F	H A/F
3/8"	M16 x 1.5	0.65 (16.5)	M20 x 1.5	94 4642 05	1.95 (49.5)	1.20 (30.5)	0.39 (10.0)	1.06 (27.0)	1.06 (27.0)
3/8"	M20 x 1.5	0.8 (20.5)	M20 x 1.5	94 4642 01	2.36 (60.0)	1.38 (35.0)	0.47 (12.0)	1.06 (27.0)	1.06 (27.0)
1/2"	M24 x 1.5	0.97 (24.5)	M24 x 1.5	94 4642 04	2.01 (51.0)	1.22 (31.0)	0.39 (10.0)	1.18 (30.0)	1.18 (30.0)

Note: Supplied complete with two locknuts. This connector can also be ordered with one locknut only (to order quote series 94 4508 88 and size).

Male Bulkhead Connectors BSP Taper, Metric

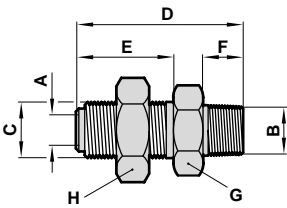

A Tube O.D.	B BSP Taper	C Thread	Panel Hole ø	Product Number	D	E	F	G A/F	H A/F
3/8"	1/2"	M20 x 1.5	0.81 (20.5)	94 4652 01	2.11 (53.5)	1.20 (30.5)	0.63 (15.9)	1.06 (27.0)	1.06 (27.0)
1/2"	1/2"	M24 x 1.5	0.97 (24.5)	94 4652 02	2.13 (54.0)	1.22 (31.0)	0.63 (15.9)	1.06 (27.0)	1.18 (30.0)

Straight Bulkhead Adapters UNF / SAE 45° Flare

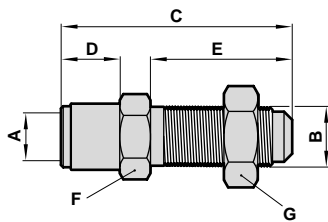

A Tube O.D.	B UNF	Product Number	C	D	E	F A/F	G A/F
1/4"	7/16"	94 4602 03	1.99 (50.5)	0.57 (14.5)	1.18 (30.0)	0.67 (17.0)	11/16"
3/8"	5/8"	94 4602 02	2.80 (71.0)	0.71 (18.0)	1.81 (46.0)	0.87 (22.0)	15/16"
1/2"	3/4"	94 4602 01	2.93 (74.5)	0.75 (19.0)	1.81 (46.0)	0.94 (24.0)	1-1/8"

Additional Bulkhead Nuts

Bulkheads include lock nuts. Refer to the numbers below to order additional nuts.		
Thread	Part Number	A/F
M12 X 1.0	95 0520 01	—
M15 X 1.0	95 0520 03	0.87 (22.0)
M20 X 1.5	95 0520 06	1.06 (27.0)
M24 X 1.5	95 0520 07	1.18 (30.0)



Plug*

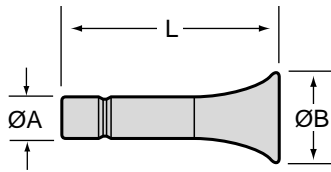

SAE 630109

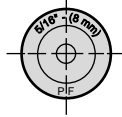

A Stem O.D.	Part Number	ØB	L
1/4"	94 0509 04	0.46 (11.6)	1.12 (28.5)
3/8"	94 0509 06	0.65 (16.6)	1.34 (34.0)
1/2"	94 0509 07	0.65 (16.4)	1.48 (37.5)

*Material: Thermoplastic

Male Elbows NPT

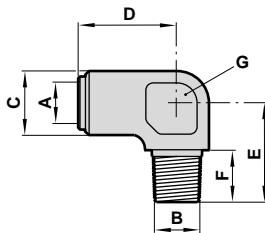

SAE 630202

A Tube O.D.	B NPT	Product Number	ØC	D	E	F	G A/F
5/32"	1/8"	70 4331 02V	0.30 (7.5)	0.67 (17.0)	.068 (17.2)	0.37 (9.5)	0.28 (7.0)
3/16"	1/8"	95 4331 03	0.47 (12.0)	0.81 (20.5)	0.75 (19.0)	0.37 (9.5)	0.47 (12.0)
1/4"	1/8"	95 4331 04	0.55 (14.0)	0.81 (20.5)	0.79 (20.0)	0.37 (9.5)	0.55 (14.0)
1/4"	1/4"	95 4331 10	0.69 (17.5)	0.87 (22.0)	1.02 (26.0)	0.56 (14.3)	0.71 (18.0)
1/4"	3/8"	95 4331 18	0.82 (20.8)	0.94 (24.0)	1.10 (28.0)	0.56 (14.3)	0.87 (22.0)
1/4"	1/2"	95 4331 27	0.94 (24.0)	0.96 (24.5)	1.38 (35.0)	0.75 (19.1)	0.94 (24.0)
5/16"	1/8"	95 4331 05	0.69 (17.5)	0.89 (22.5)	0.94 (24.0)	0.37 (9.5)	0.71 (18.0)
3/8"	1/8"	95 4331 06	0.69 (17.5)	1.08 (27.5)	0.87 (22.0)	0.37 (9.5)	0.71 (18.0)
3/8"	1/4"	95 4331 12	0.69 (17.5)	1.06 (27.0)	1.02 (26.0)	0.56 (14.3)	0.71 (18.0)
3/8"	3/8"	95 4331 20	0.82 (20.8)	1.14 (29.0)	1.10 (28.0)	0.56 (14.3)	0.87 (22.0)
3/8"	1/2"	95 4331 29	0.94 (24.0)	1.14 (29.0)	1.38 (35.0)	0.75 (19.1)	0.94 (24.0)
1/2"	1/4"	95 4331 13	0.87 (22.0)	1.22 (31.0)	1.14 (29.0)	0.56 (14.3)	0.87 (22.0)
1/2"	3/8"	95 4331 21	0.87 (22.0)	1.26 (32.0)	1.14 (29.0)	0.56 (14.3)	0.87 (22.0)
1/2"	1/2"	95 4331 30	0.94 (24.0)	1.28 (32.5)	1.38 (35.0)	0.75 (19.1)	0.94 (24.0)
1/2"	3/4"	95 4331 44	1.15 (29.3)	1.46 (37.0)	1.50 (38.0)	0.75 (19.1)	1.18 (30.0)
5/8"	3/8"	95 4331 98	1.06 (27.0)	1.44 (36.5)	1.22 (31.0)	0.56 (14.3)	0.87 (22.0)
5/8"	1/2"	95 4331 31	1.15 (29.3)	1.54 (39.0)	1.42 (36.0)	0.75 (19.1)	1.18 (30.0)
3/4"	1/2"	95 4331 49	1.30 (33.0)	1.52 (38.5)	1.48 (37.5)	0.75 (19.1)	0.94 (24.0)

Part numbers ending with a "V" have Viton seals.
5/32" fittings have a Pneufit stylebody and collet.



FleetFit Vehicle Push-In Fittings

Dimensions in Inches (mm)

Male Hobbs Elbows Metric

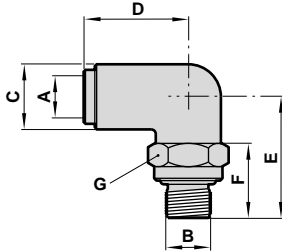

A Tube O.D.	B Thread	Product Number	ØC	D	E	F	G A/F
1/4"	M12 x 1.0	94 4138 32	0.55 (14.0)	0.93 (23.5)	1.14 (29.0)	0.75 (19.0)	0.67 (17.0)
1/4"	M12 x 1.5	94 4138 33	0.55 (14.0)	0.93 (23.5)	1.14 (29.0)	0.75 (19.0)	0.67 (17.0)
1/4"	M16 x 1.5	94 4138 35	0.69 (17.5)	0.96 (24.5)	1.34 (34.0)	0.85 (21.5)	0.94 (24.0)
1/4"	M22 x 1.5	94 4138 38	1.02 (26.0)	1.12 (28.5)	1.63 (41.5)	0.98 (25.0)	1.18 (30.0)
3/8"	M12 x 1.5	94 4138 53	0.73 (18.5)	1.14 (29.0)	1.22 (31.0)	0.75 (19.0)	0.67 (17.0)
3/8"	M14 x 1.5	94 4138 54	0.73 (18.5)	1.10 (28.0)	1.24 (31.5)	0.77 (19.5)	0.75 (19.0)
3/8"	M16 x 1.5	94 4138 55	0.73 (18.5)	1.14 (29.0)	1.32 (33.5)	0.85 (21.5)	0.94 (24.0)
3/8"	M22 x 1.5	94 4138 58	1.02 (26.0)	1.26 (32.0)	1.59 (40.5)	0.98 (25.0)	1.18 (30.0)
1/2"	M14 x 1.5	94 4138 64	0.87 (22.0)	1.28 (32.5)	1.32 (33.5)	0.77 (19.5)	0.75 (19.0)
1/2"	M16 x 1.5	94 4138 65	0.87 (22.0)	1.28 (32.5)	1.40 (35.5)	0.85 (21.5)	0.94 (24.0)
1/2"	M22 x 1.5	94 4138 68	1.02 (26.0)	1.36 (34.5)	1.59 (40.5)	0.98 (25.0)	1.18 (30.0)

Male Elbows BSP Taper

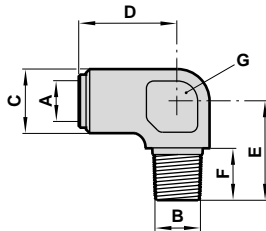

A Tube O.D.	B BSP Taper	Product Number	ØC	D	E	F	G GA/F
1/4"	1/8"	94 4330 04	0.56 (14.3)	0.81 (20.5)	0.79 (20.0)	0.37 (9.5)	0.55 (14.0)
1/4"	1/4"	94 4330 10	0.63 (15.9)	0.86 (21.8)	0.87 (22.0)	0.44 (11.1)	-
3/8"	1/4"	94 4330 12	0.69 (17.5)	0.99 (25.1)	0.94 (24.0)	0.44 (11.1)	-
3/8"	3/8"	94 4330 20	0.79 (20.0)	1.03 (26.1)	1.08 (27.5)	0.50 (12.7)	-
3/8"	1/2"	94 4330 29	0.94 (23.8)	1.19 (30.1)	1.22 (31.0)	0.63 (15.9)	-
1/2"	1/4"	94 4330 13	0.94 (23.8)	1.19 (30.1)	1.06 (27.0)	0.44 (11.1)	-
1/2"	3/8"	94 4330 21	0.94 (23.8)	1.19 (30.1)	1.12 (28.5)	0.50 (12.7)	-
1/2"	1/2"	94 4330 30	0.94 (23.8)	1.20 (30.6)	1.22 (31.0)	0.63 (15.9)	-



Male Swivel Elbows NPT

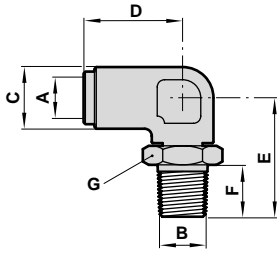

SAE 6302AA

A Tube O.D.	B NPT	Product Number	ØC	D	E	F	G A/F
1/4"	1/8"	95 4114 04	0.51 (13.0)	0.83 (21.2)	0.91 (23.2)	0.37 (9.5)	0.43 (11.0)
1/4"	1/4"	95 4114 10	0.51 (13.0)	0.83 (21.2)	1.12 (28.4)	0.56 (14.3)	0.55 (14.0)
1/4"	3/8"	95 4114 18	0.59 (15.0)	0.85 (21.5)	1.25 (31.7)	0.56 (14.3)	0.75 (19.0)
3/8"	1/8"	95 4114 06	0.67 (17.0)	1.07 (27.3)	1.05 (26.7)	0.37 (9.5)	0.55 (14.0)
3/8"	1/4"	95 4114 12	0.67 (17.0)	1.07 (27.3)	1.29 (32.7)	0.56 (14.3)	0.75 (19.0)
3/8"	3/8"	95 4114 20	0.67 (17.0)	1.07 (27.3)	1.24 (31.6)	0.56 (14.3)	0.75 (19.0)
3/8"	1/2"	95 4114 29	0.67 (17.0)	1.07 (27.3)	1.44 (36.8)	0.75 (19.0)	0.87 (22.0)
1/2"	1/4"	95 4114 13	0.81 (20.6)	1.27 (32.3)	1.27 (32.2)	0.56 (14.3)	0.87 (22.0)
1/2"	3/8"	95 4114 21	0.81 (20.6)	1.27 (32.3)	1.42 (36.1)	0.56 (14.3)	0.87 (22.0)
1/2"	1/2"	95 4114 30	0.81 (20.6)	1.27 (32.3)	1.62 (41.1)	0.75 (19.0)	0.87 (22.0)

Note: The Swivel feature should be used for positioning purposes only and should not be used as a rotating joint.

45° Male Elbows NPT

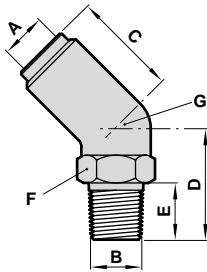

SAE 630302

A Tube O.D.	B NPT	Product Number	C	D	E	F A/F	G A/F
1/4"	1/8"	95 4600 04	0.87 (22.0)	0.81 (20.5)	0.37 (9.5)	0.56 (14.3)	-
1/4"	1/4"	95 4600 10	0.89 (22.5)	0.98 (25.0)	0.56 (14.3)	0.56 (14.3)	-
3/8"	1/8"	95 4600 06	1.02 (26.0)	0.93 (23.5)	0.37 (9.5)	0.75 (19.0)	-
3/8"	1/4"	95 4600 12	1.06 (27.0)	1.10 (28.0)	0.56 (14.3)	0.75 (19.0)	-
3/8"	3/8"	95 4600 20	1.10 (28.0)	1.12 (28.5)	0.56 (14.3)	0.75 (19.0)	-
3/8"	1/2"	95 4600 29	1.14 (29.0)	1.30 (33.0)	0.75 (19.1)	0.87 (22.0)	-
1/2"	1/4"	95 4600 13	1.22 (31.0)	1.10 (28.0)	0.56 (14.3)	0.87 (22.0)	-
1/2"	3/8"	95 4600 21	1.26 (32.0)	1.12 (28.5)	0.56 (14.3)	0.87 (22.0)	-
1/2"	1/2"	95 4600 30	1.30 (33.0)	1.30 (33.0)	0.75 (19.1)	0.87 (22.0)	-
5/8"	3/8"	95 4600 22	1.46 (37.0)	1.02 (26.0)	0.56 (14.3)	-	1.06 (27.0)
5/8"	1/2"	95 4600 31	1.46 (37.0)	1.22 (31.0)	0.75 (19.1)	-	1.06 (27.0)
3/4"	1/2"	95 4600 49	1.52 (38.5)	1.30 (33.0)	0.75 (19.1)	1.00 (25.4)	-

45° Male Hobbs Elbows Metric

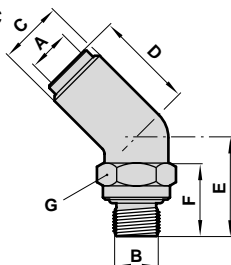

A Tube O.D.	B Thread	Product Number	ØC	D	E	F	G A/F
1/4"	M16 x 1.5	94 4301 35	0.69 (17.5)	0.96 (24.5)	1.16 (29.5)	0.85 (21.5)	0.94 (24.0)
3/8"	M16 x 1.5	94 4301 55	0.69 (17.5)	1.16 (29.5)	1.16 (29.5)	0.85 (21.5)	0.94 (24.0)



FleetFit Vehicle Push-In Fittings

Dimensions in Inches (mm)

Female Elbows

NPT

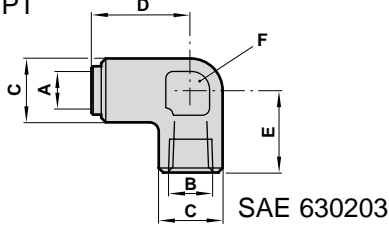

SAE 630203

A Tube O.D.	B NPT	Product Number	ØC	D	E	F A/F
3/16"	1/8"	95 4564 01	0.55 (14.0)	0.87 (22.0)	0.71 (18.0)	0.55 (14.0)
1/4"	1/8"	95 4562 04	0.55 (14.0)	0.94 (24.0)	0.71 (18.0)	0.55 (14.0)

45° Female Elbows

NPT

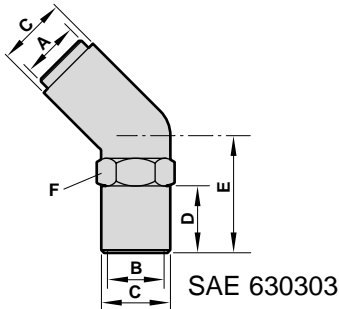

SAE 630303

A Tube O.D.	B NPT	Product Number	ØC	D	E	F A/F
3/8"	1/8"	95 4470 06	0.70 (17.7)	0.59 (1.5)	0.57 (14.5)	0.75 (19.0)

Union Elbows

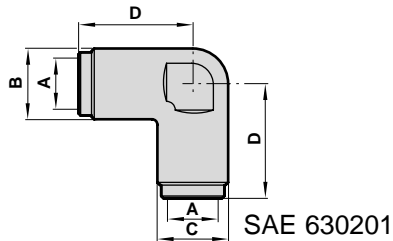

SAE 630201

A Tube O.D.	Product Number	ØB	ØC	D
1/4"	94 4511 04	0.43 (11.0)	0.51 (13.0)	0.83 (21.0)
3/8"	94 4511 06	0.57 (14.5)	0.67 (17.0)	1.07 (27.1)
1/2"	94 4511 07	0.71 (18.0)	0.81 (20.5)	1.26 (32.1)

Union Bulkhead Elbows

Metric

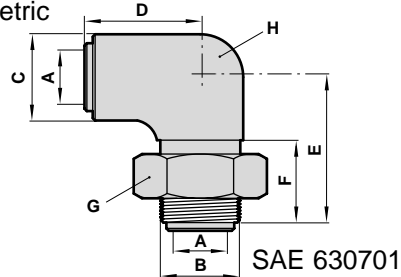

SAE 630701

A Tube O.D.	B Thread	Product Number	Panel Hole ø	ØC	D	E	F	G A/F	H A/F	J A/f
1/4"	M15 x 1.0	94 4591 04	0.6 (15.5)	0.69 (17.5)	0.85 (21.5)	1.12 (28.5)	0.65 (16.5)	0.87 (22.0)	0.71 (18.0)	-
3/8"	M20 x 1.5	94 4591 06	0.8 (20.5)	0.94 (23.8)	1.08 (27.5)	1.54 (39.0)	0.89 (22.5)	1.06 (27.0)	-	-
1/2"	M24 x 1.5	94 4591 07	0.96 (26.5)	1.06 (27.0)	1.28 (32.5)	1.54 (39.0)	0.89 (22.5)	1.18 (30.0)	1.06 (27.0)	-

Male Bulkhead Elbows

NPT Female, UNF

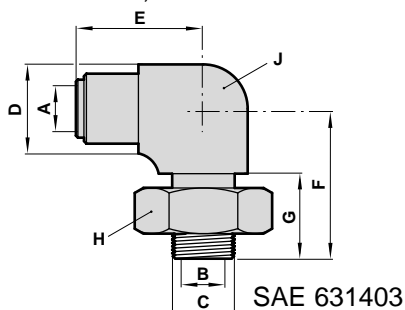

SAE 631403

A Tube O.D.	B NPT Female	C UNF	Product Number	ØD	E	F	G	H A/F	J A/f
1/4"	1/8"	5/8"	95 4597 04	0.81 (20.7)	1.00 (25.5)	1.18 (30.0)	0.63 (16.0)	15/16"	0.87 (22.0)
3/8"	3/8"	7/8"	95 4597 01	1.02 (26.0)	1.17 (29.7)	1.61 (41.0)	0.98 (25.0)	1-5/16"	0.67 (17.0)
1/2"	3/8"	7/8"	95 4597 02	1.02 (26.0)	1.33 (33.7)	1.61 (41.0)	0.98 (25.0)	1-5/16"	0.67 (17.0)
5/8"	3/8"	7/8"	95 4597 03	1.02 (26.0)	1.48 (37.5)	1.61 (41.0)	0.98 (25.0)	1-5/16"	0.67 (17.0)



Double Elbow Adapters NPT

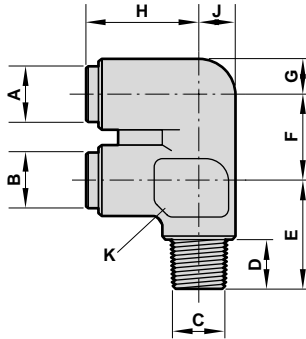

A Tube O.D.	B Tube O.D.	C NPT	Product Number	D	E	F	G	H	J	K A/F
1/4"	1/4"	1/8"	95 4761 01	0.37 (9.5)	0.83 (21.0)	0.67 (17.0)	0.28 (7.0)	0.89 (22.5)	0.28 (7.0)	0.55 (14.0)

Bulkhead Elbow Adapters UNF / SAE 45° Flare

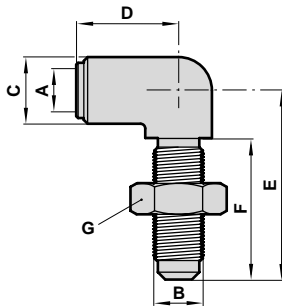

Tube O.D.	B UNF	Product Number	ØC	D	E	F	G A/F
1/4"	7/16"	94 4607 05	0.56 (14.3)	0.85 (21.5)	1.57 (40.0)	1.18 (30.0)	1-1/16"
3/8"	5/8"	94 4607 02	0.98 (25.0)	1.10 (28.0)	2.44 (62.0)	1.81 (46.0)	1-5/16"
1/2"	5/8"	94 4607 03	0.98 (25.0)	1.26 (32.0)	2.44 (62.0)	1.81 (46.0)	1-5/16"
1/2"	3/4"	94 4607 04	0.98 (25.0)	1.26 (32.0)	2.44 (62.0)	1.81 (46.0)	1-1/8"

Male Branch Tees NPT

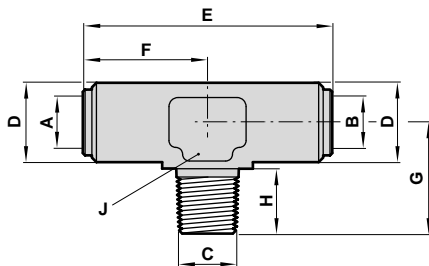

SAE 630425

A Tube O.D.	B Tube O.D.	C NPT	Product Number	ØD	E	F	G	H	J A/F
1/4"	1/4"	1/8"	95 4590 02	0.55 (14.0)	1.69 (43.0)	0.85 (21.5)	0.79 (20.0)	0.37 (9.5)	0.55 (14.0)
1/4"	1/4"	1/4"	95 4590 12	0.69 (17.5)	1.77 (45.0)	0.89 (22.5)	0.96 (24.5)	0.56 (14.3)	0.71 (18.0)
1/4"	1/4"	3/8"	95 4590 19	0.82 (20.8)	1.93 (49.0)	0.96 (24.5)	1.10 (28.0)	0.56 (14.3)	0.87 (22.0)
3/8"	1/4"	1/4"	95 4590 16	0.69 (17.5)	1.97 (50.0)	0.89 (22.5)	0.96 (24.5)	0.56 (14.3)	0.71 (18.0)
3/8"	3/8"	1/4"	95 4590 10	0.69 (17.5)	2.17 (55.0)	1.08 (27.5)	0.96 (24.5)	0.56 (14.3)	0.71 (18.0)
3/8"	3/8"	3/8"	95 4590 01	0.82 (20.8)	2.28 (58.0)	1.14 (29.0)	1.10 (28.0)	0.56 (14.3)	0.87 (22.0)
1/2"	1/4"	1/4"	95 4590 09	0.87 (22.0)	2.15 (54.5)	0.93 (23.5)	1.14 (29.0)	0.56 (14.3)	0.87 (22.0)
1/2"	1/4"	3/8"	95 4590 06	0.87 (22.0)	2.26 (57.5)	0.96 (24.5)	1.14 (29.0)	0.56 (14.3)	0.87 (22.0)
1/2"	1/4"	1/2"	95 4590 08	0.91 (23.0)	2.34 (59.5)	1.00 (25.5)	1.42 (36.0)	0.75 (19.1)	0.94 (24.0)
1/2"	3/8"	1/2"	95 4590 14	0.87 (22.0)	2.48 (63.0)	1.18 (30.0)	1.22 (31.0)	0.75 (19.1)	0.87 (22.0)
1/2"	1/2"	1/4"	95 4590 13	0.87 (22.0)	2.44 (62.0)	1.22 (31.0)	1.14 (29.0)	0.56 (14.3)	0.87 (22.0)
1/2"	1/2"	3/8"	95 4590 05	0.87 (22.0)	2.60 (66.0)	1.30 (33.0)	1.14 (29.0)	0.56 (14.3)	0.87 (22.0)
1/2"	1/2"	1/2"	95 4590 04	0.91 (23.0)	2.68 (68.0)	1.34 (34.0)	1.42 (36.0)	0.75 (19.1)	0.94 (24.0)
5/8"	1/2"	3/8"	95 4590 15	1.14 (29.0)	2.78 (70.5)	1.30 (33.0)	1.26 (32.0)	0.56 (14.3)	1.18 (30.0)
5/8"	1/2"	1/2"	95 4590 07	1.14 (29.0)	2.78 (70.5)	1.30 (33.0)	1.46 (37.0)	0.75 (19.1)	1.18 (30.0)



FleetFit Vehicle Push-In Fittings

Dimensions in Inches (mm)

Hobbs Tee Adapters Metric

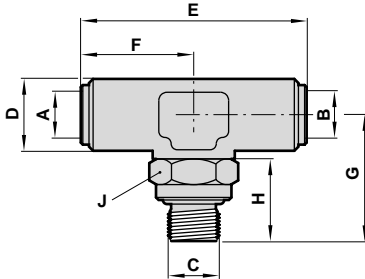

A Tube O.D.	B Tube O.D.	C Thread	Product Number	D	E	F	G	H	J A/F
1/4"	1/4"	M16 x 1.5	94 4439 15	0.71 (18.0)	1.89 (48.0)	0.94 (24.0)	1.32 (33.5)	0.85 (21.5)	0.94 (24.0)
1/2"	1/2"	M22 x 1.5	94 4639 06	0.87 (22.0)	2.83 (72.0)	1.42 (36.0)	1.69 (43.0)	0.98 (25.0)	1.06 (27.0)

Male Branch Tees BSP Taper

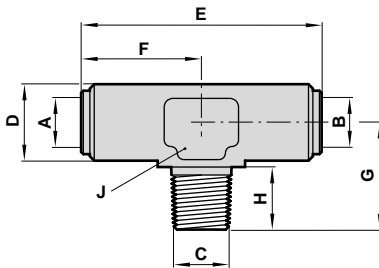

A Tube O.D.	B Tube O.D.	C BSP Taper	Product Number	ØD	E	F	G	H	J A/F
1/4"	1/4"	1/4"	94 4590 12	0.55 (14.0)	1.69 (43.0)	0.85 (21.5)	0.81 (20.5)	0.44 (11.1)	0.55 (14.0)
3/8"	3/8"	1/4"	94 4590 10	0.69 (17.4)	2.17 (55.0)	1.08 (27.5)	0.93 (23.5)	0.44 (11.1)	0.71 (18.0)

Special Tee Adapters NPT, NPT Female

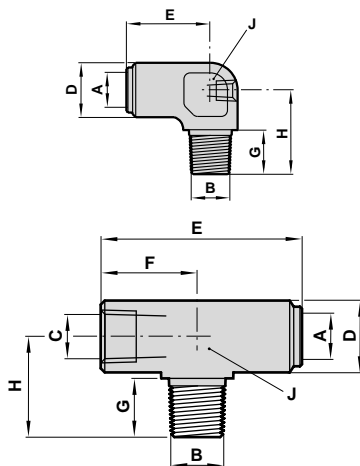

A Tube O.D.	B NPT	NPT Female	Product Number	ØD	E	F	G	H	J A/F
3/8"	1/4"	1/4"	95 4593 09	0.69 (17.4)	2.05 (52.0)	0.96 (24.5)	0.56 (14.3)	0.96 (24.5)	0.71 (18.0)
3/8"	3/8"	1/4"	95 4593 11	0.82 (20.8)	1.89 (48.0)	0.75 (19.0)	0.56 (14.3)	1.10 (28.0)	0.87 (22.0)
3/8"	1/2"	1/4"	95 4593 03	0.91 (23.0)	2.20 (56.0)	0.98 (25.0)	0.75 (19.1)	1.42 (36.0)	0.94 (24.0)
1/2"	3/8"	1/4"	95 4593 07	0.87 (22.0)	2.24 (57.0)	0.94 (24.0)	0.56 (14.3)	1.14 (29.0)	0.87 (22.0)
1/2"	1/2"	1/8"	95 4593 06*	0.94 (24.0)	1.28 (32.5)	-	0.75 (19.1)	1.38 (35.0)	0.94 (24.0)
1/2"	1/2"	1/4"	95 4593 02	0.91 (23.0)	2.32 (59.0)	0.98 (25.0)	0.75 (19.1)	1.42 (36.0)	0.94 (24.0)

*Top diagram refers to 95 4593 06.



Universal Hobbs Tee Adapters Metric, NPT Female

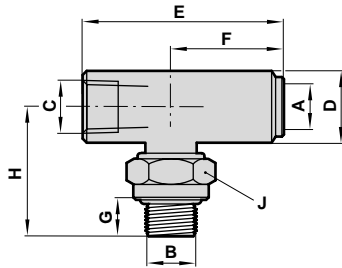

A Tube O.D.	B Thread	C NPT Female	Product Number	ØD	E	F	G	H	J A/F
3/8"	M16 x 1.5	1/4"	95 4621 03	0.75 (19.0)	2.07 (52.5)	1.12 (28.5)	0.41 (10.5)	1.32 (33.5)	0.87 (22.0)
3/8"	M22 x 1.5	1/4"	95 4621 02	0.87 (22.0)	2.20 (56.0)	1.26 (32.0)	0.51 (13.0)	1.69 (43.0)	1.06 (27.0)
1/2"	M22 x 1.5	1/4"	95 4621 01	0.87 (22.0)	2.36 (60.0)	1.42 (36.0)	0.51 (13.0)	1.69 (43.0)	1.06 (27.0)

Male Swivel Branch Tees NPT

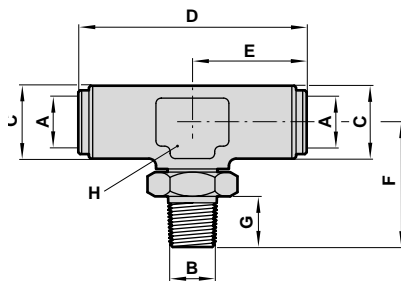

SAE 6304AC

CAUTION: Swivel Adapters are not suitable for use in continuously rotating or gyrating applications.

A Tube O.D.	B NPT	Product Number	ØC	D	E	F	G	H A/F
1/4"	1/8"	95 4111 04	0.51 (13.0)	1.67 (42.4)	0.83 (21.2)	0.91 (23.2)	0.37 (9.5)	0.43 (11.0)
1/4"	1/4"	95 4111 10	0.51 (13.0)	1.67 (42.4)	0.83 (21.2)	1.12 (28.4)	0.56 (14.3)	0.55 (14.0)
3/8"	1/4"	95 4111 12	0.67 (17.0)	2.17 (55.0)	1.08 (27.5)	1.29 (32.7)	0.56 (14.3)	0.75 (19.0)
3/8"	3/8"	95 4111 20	0.67 (17.0)	2.17 (55.0)	1.08 (27.5)	1.24 (31.6)	0.56 (14.3)	0.75 (19.0)
1/2"	1/4"	95 4111 13	0.81 (20.6)	2.56 (65.0)	1.28 (32.5)	1.39 (35.2)	0.56 (14.3)	0.87 (22.0)
1/2"	1/2"	95 4111 30	0.81 (20.6)	2.56 (65.0)	1.28 (32.5)	1.62 (41.1)	0.75 (19.1)	0.87 (22.0)

Tee Adapters Metric

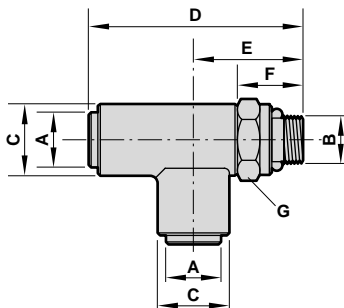

A Tube O.D.	B NPT	Product Number	ØC	D	E	F	G A/F
1/4"	M12 x M15	94 4440 20	0.55 (14.0)	2.07 (52.5)	1.14 (29.0)	0.75 (19.0)	0.67 (17.0)



FleetFit Vehicle Push-In Fittings

Dimensions in Inches (mm)

Male Run Tees NPT

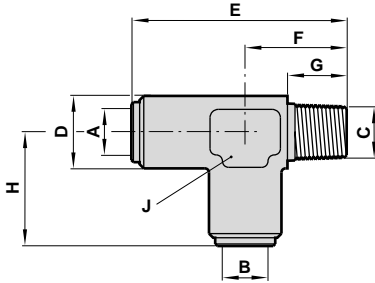

SAE 630424

A Tube O.D.	B Tube O.D.	C NPT	Product Number	ØD	E	F	G	H	J A/F
1/4"	1/4"	1/8"	95 4586 28	0.55 (14.0)	1.67 (42.5)	0.79 (20.0)	0.37 (9.5)	0.89 (22.5)	0.55 (14.0)
1/4"	1/4"	1/4"	95 4586 13	0.69 (17.5)	1.85 (47.0)	0.96 (24.5)	0.56 (14.3)	0.89 (22.5)	0.71 (18.0)
1/4"	1/4"	3/8"	95 4586 17	0.82 (20.8)	2.03 (51.5)	1.10 (28.0)	0.56 (14.3)	0.93 (23.5)	0.87 (22.0)
1/4"	3/8"	1/4"	95 4586 21	0.69 (17.5)	1.85 (47.0)	0.96 (24.5)	0.56 (14.3)	1.08 (27.5)	0.71 (18.0)
1/4"	3/8"	3/8"	95 4586 07	0.82 (20.8)	2.03 (51.5)	1.10 (28.0)	0.56 (14.3)	1.14 (29.0)	0.87 (22.0)
1/4"	1/2"	3/8"	95 4586 06	0.87 (22.0)	2.11 (53.5)	1.14 (29.0)	0.56 (14.3)	1.30 (33.0)	0.87 (22.0)
1/4"	1/2"	1/2"	95 4586 18	0.91 (23.0)	2.34 (59.5)	1.42 (36.0)	0.75 (19.1)	1.30 (33.0)	0.94 (24.0)
1/4"	5/8"	3/8"	95 4586 14	1.14 (29.0)	2.38 (60.5)	1.26 (32.0)	0.56 (14.3)	1.54 (39.0)	1.18 (30.0)
3/8"	1/4"	1/4"	95 4586 05	0.69 (17.5)	2.05 (52.0)	0.96 (24.5)	0.56 (14.3)	0.93 (23.5)	0.71 (18.0)
3/8"	1/4"	3/8"	95 4586 27	0.82 (20.8)	2.24 (57.0)	1.10 (28.0)	0.56 (14.3)	0.93 (23.5)	0.87 (22.0)
3/8"	3/8"	1/4"	95 4586 03	0.69 (17.5)	2.05 (52.0)	0.96 (24.5)	0.56 (14.3)	1.08 (27.5)	0.71 (18.0)
3/8"	3/8"	3/8"	95 4586 10	0.82 (20.8)	2.24 (57.0)	1.10 (28.0)	0.56 (14.3)	1.14 (29.0)	0.87 (22.0)
3/8"	3/8"	1/2"	95 4586 04	0.91 (23.0)	2.64 (67.0)	1.42 (36.0)	0.75 (19.1)	1.22 (31.0)	0.94 (24.0)
3/8"	1/2"	3/8"	95 4586 26	0.87 (22.0)	2.36 (60.0)	1.14 (29.0)	0.56 (14.3)	1.30 (33.0)	0.87 (22.0)
1/2"	1/4"	1/2"	95 4586 02	0.91 (23.0)	2.64 (67.0)	1.42 (36.0)	0.75 (19.1)	1.04 (26.5)	0.94 (24.0)
1/2"	3/8"	3/8"	95 4586 20	0.87 (22.0)	2.44 (62.0)	1.14 (29.0)	0.56 (14.3)	1.22 (31.0)	0.87 (22.0)
1/2"	1/2"	1/4"	95 4586 16	0.87 (22.0)	2.44 (62.0)	1.14 (29.0)	0.56 (14.3)	1.30 (33.0)	0.87 (22.0)
1/2"	1/2"	3/8"	95 4586 11	0.87 (22.0)	2.44 (62.0)	1.14 (29.0)	0.56 (14.3)	1.30 (33.0)	0.87 (22.0)
1/2"	1/2"	1/2"	95 4586 15	0.91 (23.0)	2.72 (69.0)	1.42 (36.0)	0.75 (19.1)	1.30 (33.0)	0.94 (24.0)

Side Tee Adapters NPT, NPT Female

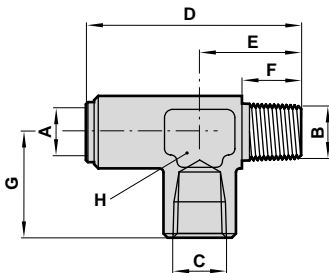

SAE 630835

A Tube O.D.	B NPT	C NPT Female	Product Number	D	E	F	G	H A/F
1/4"	1/4"	1/4"	95 4585 10	1.97 (50.0)	0.96 (24.5)	0.56 (14.3)	0.96 (24.5)	0.71 (18.0)
3/8"	1/4"	1/4"	95 4585 03	2.05 (52.0)	0.96 (24.5)	0.56 (14.3)	0.96 (24.5)	0.71 (18.0)
3/8"	1/4"	1/8"	95 4585 11	2.07 (52.5)	0.96 (24.5)	0.56 (14.3)	0.79 (20.0)	0.71 (18.0)
1/2"	3/8"	1/4"	95 4585 05	2.44 (62.0)	1.14 (29.0)	0.56 (14.3)	0.98 (25.0)	0.87 (22.0)
1/2"	1/2"	1/8"	95 4585 02	2.40 (61.0)	1.08 (27.5)	0.75 (19.1)	-	0.94 (24.0)
1/2"	1/2"	1/4"	95 4585 04	2.72 (69.0)	1.42 (36.0)	0.75 (19.1)	0.98 (25.0)	0.94 (24.0)



Side Tee Adapters NPT, NPT Female

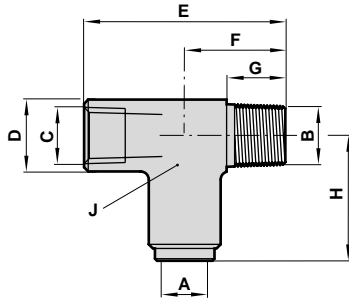

A Tube O.D.	B NPT	C NPT Female	Product Number	D	E	F	G	H	J A/F
3/8"	1/4"	1/4"	95 4587 01	0.34 (8.7)	1.93 (49.0)	0.96 (24.5)	0.56 (14.3)	1.08 (27.5)	0.71 (18.0)

Male Swivel Run Tees NPT

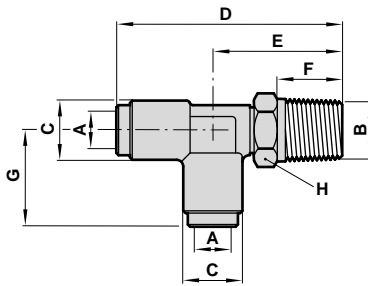

SAE 6308AB

A Tube O.D.	B NPT	Product Number	ØC	D	E	F	G	H A/F
1/4"	1/8"	95 4112 04	0.51 (13.0)	1.75 (44.4)	0.91 (23.2)	0.37 (9.5)	0.83 (21.2)	0.43 (11.0)
1/4"	1/4"	95 4112 10	0.51 (13.0)	1.95 (49.6)	1.12 (28.4)	0.56 (14.3)	0.83 (21.2)	0.55 (14.0)
3/8"	1/4"	95 4112 12	0.67 (17.0)	2.36 (60.0)	1.29 (32.7)	0.56 (14.3)	1.07 (27.3)	0.75 (19.0)
3/8"	3/8"	95 4112 20	0.67 (17.0)	2.32 (58.9)	1.24 (31.6)	0.56 (14.3)	1.07 (27.3)	0.75 (19.0)
3/8"	1/2"	95 4112 29	0.67 (17.0)	2.50 (64.1)	1.44 (36.8)	0.75 (19.1)	1.07 (27.3)	0.87 (22.0)
1/2"	1/4"	95 4112 13	0.81 (20.6)	2.15 (54.5)	1.27 (32.2)	0.56 (14.3)	1.27 (32.3)	0.87 (22.0)
1/2"	3/8"	95 4112 21	0.81 (20.6)	2.69 (68.4)	1.42 (36.1)	0.56 (14.3)	1.27 (32.3)	0.87 (22.0)
1/2"	1/2"	95 4112 30	0.81 (20.6)	2.89 (73.4)	1.62 (41.1)	0.75 (19.1)	1.27 (32.3)	0.87 (22.0)

Note: The Swivel feature should be used for positioning purposes only and should not be used as a rotating joint.

Special Tee Adaptors NPT Female, NPT

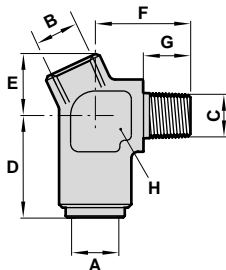

A Tube O.D.	B NPT Female	C NPT	Product Number	D	E	F	G	H A/F
1/2"	1/4"	1/4"	95 4563 01	1.22 (31.0)	0.75 (19.0)	1.14 (29.0)	0.56 (14.3)	0.87 (22.0)
1/2"	1/4"	3/8"	95 4563 02	1.30 (33.0)	0.75 (19.0)	1.14 (29.0)	0.56 (14.3)	0.87 (22.0)

Special Hobbs Side Tee Adaptors Metric, NPT Female

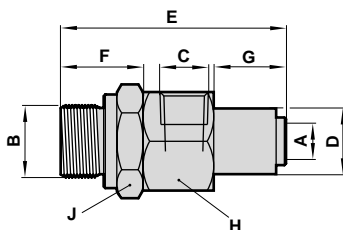

A Tube O.D.	B Thread	C NPT Female	Product Number	ØD	E	F	G	H A/F	J A/F
3/8"	M22 x 1.5	1/4"	95 4423 01	0.79 (20.0)	2.74 (69.5)	0.98 (25.0)	0.87 (22.0)	1.18 (30.0)	1.18 (30.0)



FleetFit Vehicle Push-In Fittings

Dimensions in Inches (mm)

Special 90° Bulkhead Tees NPT

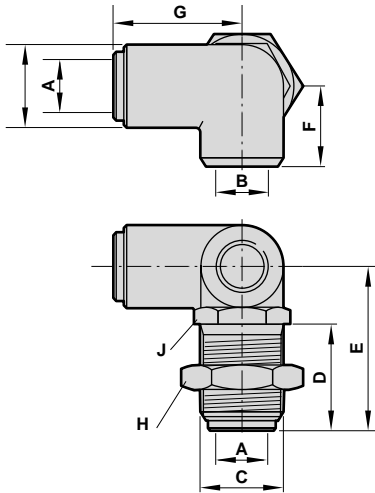

A Tube O.D.	B NPT	C NPT	Product Number	ØD	E	F	G	H A/F	J A/F
1/4"	1/4"	5/8"	95 4679 01	0.85 (21.5)	1.63 (41.5)	0.71 (18.0)	1.04 (26.5)	15/16"	0.87 (22.0)

Special 90° Tees NPT

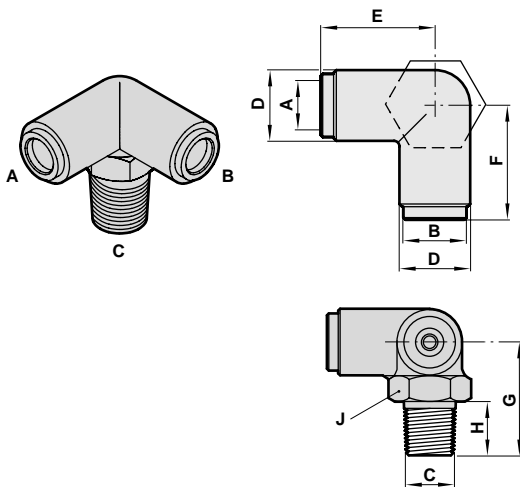

A Tube O.D.	B Tube O.D.	C NPT	Product Number	ØD	E	F	G	H	J A/F
1/4"	1/4"	1/4"	95 4589 01	0.55 (14.0)	0.93 (23.5)	0.93 (23.5)	1.07 (27.3)	0.56 (14.3)	0.55 (14.0)
1/4"	3/8"	3/8"	95 4589 11	0.85 (21.6)	1.04 (26.5)	1.14 (29.0)	1.34 (34.0)	0.56 (14.3)	0.87 (22.0)
3/8"	3/8"	3/8"	95 4589 19	0.85 (21.6)	1.18 (30.0)	1.30 (33.0)	1.34 (34.0)	0.56 (14.3)	0.87 (22.0)
3/8"	3/8"	1/4"	95 4589 16	0.85 (21.6)	1.14 (29.0)	1.14 (29.0)	1.34 (34.0)	0.56 (14.3)	0.87 (22.0)
3/8"	1/2"	3/8"	95 4589 10	0.85 (21.6)	1.18 (30.0)	1.30 (33.0)	1.34 (34.0)	0.56 (14.3)	0.87 (22.0)
3/8"	1/2"	1/2"	95 4589 07	0.85 (21.6)	1.18 (30.0)	1.30 (33.0)	1.54 (39.0)	0.75 (19.1)	0.87 (22.0)
1/2"	1/2"	3/8"	95 4589 04	0.85 (21.6)	1.30 (33.0)	1.30 (33.0)	1.34 (34.0)	0.56 (14.3)	0.87 (22.0)
1/2"	1/2"	1/2"	95 4589 02	0.85 (21.6)	1.30 (33.0)	1.30 (33.0)	1.54 (39.0)	0.75 (19.1)	0.87 (22.0)
1/2"	5/8"	1/2"	95 4589 05	1.15 (29.2)	1.46 (37.0)	1.63 (41.5)	1.69 (43.0)	0.75 (19.1)	0.87 (22.0)
5/8"	5/8"	1/2"	95 4589 06	1.15 (29.2)	1.63 (41.5)	1.63 (41.5)	1.69 (43.0)	0.75 (19.1)	0.87 (22.0)

90° Fixed Tee with side tapped port

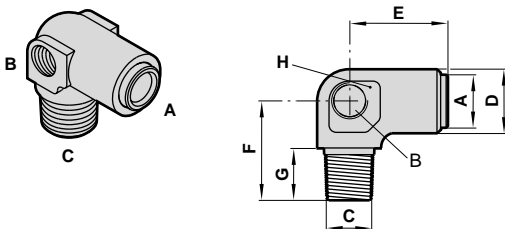

A Tube O.D.	B NPT Female	C NPT	Product Number	ØD	E	F	G	H A/F
1/2"	1/4"	1/2"	95 4584 02	0.94 (24.0)	1.28 (32.5)	1.38 (35.0)	0.75 (19.1)	0.94 (24.0)



90° Fixed Tee

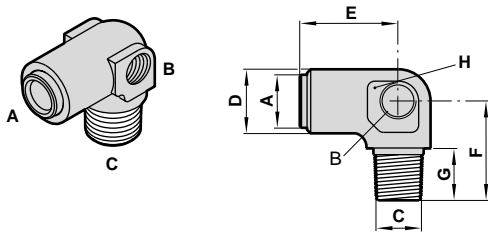

Note: Ports are threaded on side shown.

A O/D Tube	B NPT Female	C NPT	Product Number	ØD	E	F	G	H A/F
3/8"	1/8"	3/8"	95 4565 03	0.83 (21.0)	1.12 (28.5)	1.10 (28.0)	0.56 (14.3)	0.87 (22.0)
3/8"	1/8"	1/4"	95 4565 04	0.83 (21.0)	1.20 (30.5)	1.10 (28.0)	0.56 (14.3)	0.87 (22.0)
1/2"	1/8"	3/8"	95 4565 01	0.87 (22.0)	1.26 (32.0)	1.14 (29.0)	0.56 (14.3)	0.87 (22.0)
1/2"	1/4"	1/2"	95 4565 02	0.94 (24.0)	1.28 (32.5)	1.38 (35.0)	0.75 (19.1)	0.94 (24.0)
3/4"	1/4"	1/2"	95 4565 05	—	1.52 (38.5)	1.48 (37.5)	0.75 (19.1)	0.94 (24.0)

45° Tee Adapter

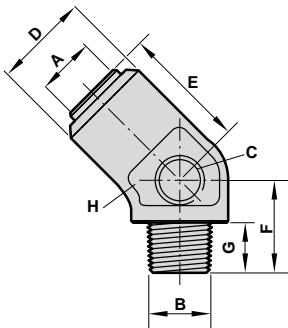

Note: Ports are threaded on opposite side shown.

A O/D Tube	B NPT	C NPT	Product Number	ØD	E	F	G	H A/F
1/2"	3/8"	1/4"	95 4653 02	1.06 (27.0)	1.38 (35.0)	1.02 (26.0)	0.56 (14.3)	1.06 (27.0)
5/8"	3/8"	1/8"	95 4653 03	1.06 (27.0)	1.46 (37.0)	1.02 (26.0)	0.56 (14.3)	1.06 (27.0)

45° Tee Adapter

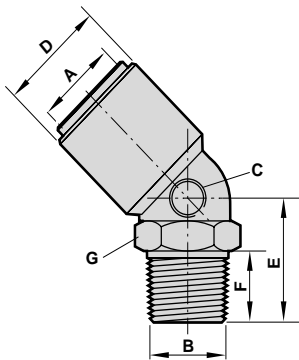

Note: Ports are threaded on side shown.

A O/D Tube	B NPT	C NPT	Product Number	ØD	E	F	G A/F
1/2"	3/8"	1/4"	95 4656 02	1.06 (27.0)	1.02 (26.0)	0.56 (14.3)	1.06 (27.0)
3/4"	1/2"	1/8"	95 4656 01	1.18 (30.0)	1.30 (33.0)	0.75 (19.1)	1.00 (25.4)

Special Bracketed Tee Adaptors NPT Female

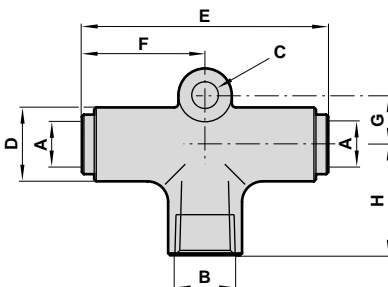

A O/D Tube	B NPT Female	C ØC	Product Number	ØD	E	F	G	H
3/8"	1/4"	0.26 (6.5)	95 4622 02	0.75 (19.0)	2.34 (59.4)	1.17 (29.7)	0.47 (12.0)	1.06 (27.0)



FleetFit Vehicle Push-In Fittings

Dimensions in Inches (mm)

Special 4-Way Adaptors NPT Female

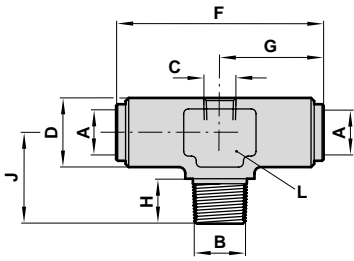

A O/D Tube	B NPT	C NPT Female	Product Number	D	E	F	G	H	J	K	L A/F
1/4"	1/4"	1/4"	95 4594 03*	0.69 (17.5)	0.69 (17.5)	1.93 (49.0)	0.96 (24.5)	0.49 (12.5)	0.87 (22.0)	1.73 (44.0)	- -
1/2"	3/8"	1/8"	95 4594 04	0.87 (22.0)	-	2.60 (66.0)	1.30 (33.0)	0.56 (14.3)	1.14 (29.0)	-	0.08 (2.0)
1/2"	1/2"	1/8"	95 4594 02	1.14 (29.0)	-	2.76 (70.0)	1.38 (35.0)	0.75 (19.1)	1.56 (39.5)	-	1.18 (30.0)
1/2"	1/2"	1/4"	95 4594 01	1.14 (29.0)	-	2.76 (70.0)	1.38 (35.0)	0.75 (19.1)	1.56 (39.5)	-	1.18 (30.0)

* Special SAE short thread

Union Tee

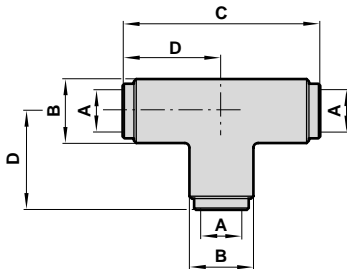

SAE 630401

A O/D Tube	Product Number	ØB	C	D
1/4"	94 4514 04	0.51 (13.0)	1.65 (42.0)	0.83 (21.0)
3/8"	94 4514 06	0.67 (17.0)	2.13 (54.2)	1.07 (27.1)
1/2"	94 4514 07	0.81 (20.5)	2.53 (64.2)	1.26 (32.1)
5/8"	94 4514 08	1.06 (27.0)	3.07 (78.0)	1.54 (39.0)

Reducing Tee Connectors

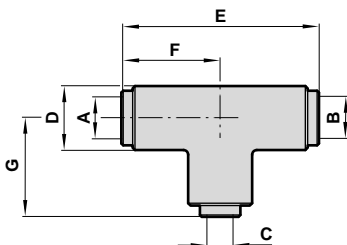

SAE 630401

A O/D Tube	B O/D Tube	C O/D Tube	Product Number	ØD	E	F	G
1/4"	1/4"	3/8"	94 4588 17	0.68 (17.2)	1.85 (47.0)	0.93 (23.5)	1.08 (27.5)
3/8"	1/4"	1/4"	94 4588 16	0.68 (17.2)	2.01 (51.0)	1.08 (27.5)	0.93 (23.5)
3/8"	3/8"	1/4"	94 4588 01	0.68 (17.2)	2.17 (55.0)	1.08 (27.5)	0.93 (23.5)
3/8"	3/8"	1/2"	94 4588 02	0.81 (20.6)	2.36 (60.0)	1.18 (30.0)	1.28 (32.5)
1/2"	3/8"	3/8"	94 4588 04	0.81 (20.6)	2.46 (62.5)	1.28 (32.5)	1.18 (30.0)
1/2"	1/2"	1/4"	94 4588 10	0.81 (20.6)	2.52 (64.0)	1.26 (32.0)	0.98 (25.0)
1/2"	1/2"	3/8"	94 4588 11	0.81 (20.6)	2.44 (62.0)	1.22 (31.0)	1.22 (31.0)
5/8"	1/2"	5/8"	94 4588 14	1.06 (27.0)	3.01 (76.5)	1.56 (39.5)	1.56 (39.5)



Special Bracketed Reducing Tee Connectors

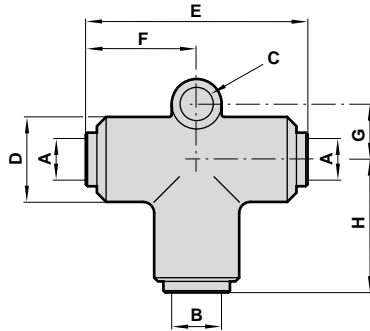

A O/D Tube	B O/D Tube	ØC	Product Number	ØD	E	F	G	H
3/8"	1/2"	0.35 (9.0)	94 4688 02	0.91 (23.0)	2.36 (60.0)	1.18 (30.0)	0.59 (15.0)	1.42 (36.0)

Special Bulkhead Tees UNF / SAE 45° flare

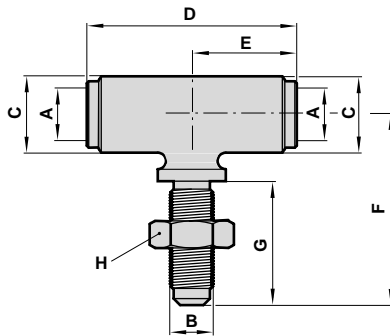

A O/D Tube	B UNF	Product Number	ØC	D	E	F	G	H A/F
3/8"	5/8"	94 4598 04	0.87 (22.0)	2.13 (54.0)	1.06 (27.0)	2.44 (62.0)	1.69 (43.0)	1-5/16"
3/8"	3/4"	94 4598 01	0.87 (22.0)	2.20 (56.0)	1.10 (28.0)	2.56 (65.0)	1.81 (46.0)	1-1/8"
1/2"	5/8"	94 4598 05	0.87 (22.0)	2.52 (64.0)	1.26 (32.0)	2.56 (65.0)	1.81 (46.0)	1-5/16"

6 Port Manifold*

A O/D Tube	B O/D Tube	Product Number	C	D	E	F	G	H	J	K	L
1/4"	3/8"	94 8125 00	0.22 (5.7)	2.76 (70.0)	0.63 (16.0)	0.62 (15.8)	4.10 (103.0)	0.87 (22.0)	0.75 (19.0)	0.47 (12.0)	1.33 (33.8)

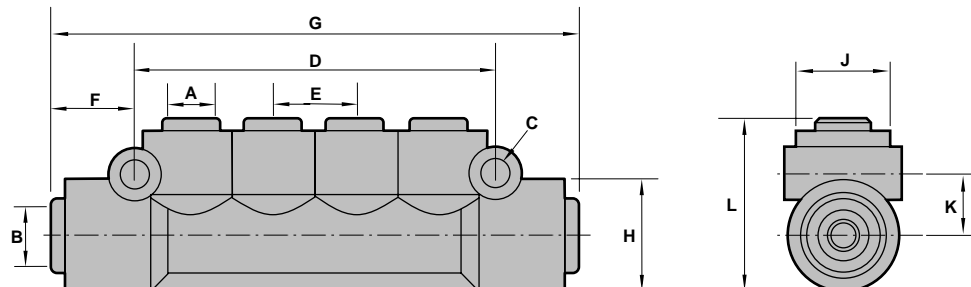

* Materials of construction: Thermoplastic body, with brass inserts and collets.



WeldFit Push-in Fittings

**1/4" to 1/2" and
6 to 12mm Tube Sizes
1/8" to 1/2" NPT and
ISO G Thread Options**

WeldFit Product Numbering SystemFIT-5-2
WeldFit Shapes and CodesFIT-5-3
WeldFit SpecificationsFIT-5-4
WeldFit Push-in Fittings (inch)FIT-5-5
WeldFit Push-in Fittings (metric)FIT-5-8
WeldTubeFIT-5-12
WeldTube Jacket StriperFIT-5-14



Position → 1 2 3 4 5 6 7 8 9 (V)

Fitting Series Number

- 10 Brass push-in fittings (metric) nickel plate + washers, sealant, assembled
- 11 Plastic push-in fittings (metric)
- 12 Brass push-in fittings (inch) nickel plate + washers, sealant assembled
- 13 Plastic push-in fittings (inch)
- 15 ISO R Pipe Fittings Brass Nickel Plate
- 16 ISO G Pipe Fittings Brass Nickel Plate + Washers Assembled
- 20 ISO G Banjo Bolts
- 21 Metric WeldFit
- 33 Inch WeldFit

Suffix Position (Optional)

- BP Bulk packaging
- GR ISO R thread
- V Viton seals
- XA Without thread sealant

Thread Size

- 18 1/8
- 28 1/4
- 38 3/8
- 48 1/2
- UNF**
- 10 10-32
- Metric**
- 05 M5 x 0.8

Thread/Banjo Bolt

- 0 No port thread
- 1 ISO R
- 2 ISO G + M5
- 4 NPT + 10-32 UNF
- A Single bolt
- B Double bolt
- C Triple bolt
- D Single bolt M5 top port
- E Single bolt G 1/8 top port
- F Single bolt G 1/4 top port
- G Single bolt G 3/8 top port
- J Single bolt with test point
- K ISO G Single bolt - regulating out
- T ISO R Single bolt - regulating out
- V NPT Single bolt - regulating out
- W NPT Single bolt - regulating out
- Z NPT Single bolt - bi-directional

Tube Size

Inch O.D.		Metric O.D.	
01	1/8"	04	4 mm
02	5/32"	05	5 mm
03	3/16"	06	6 mm
04	1/4"	08	8 mm
05	5/16"	10	10 mm
06	3/8"	12	12 mm
07	1/2"	14	14 mm

Fitting Shape

See facing page for shapes and codes.



**Positions 4 and 5 denote fitting shape
Inch Sizes**



20 Union
– O/D tube to
O/D tube
p. FIT-5-5

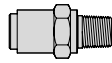

25 Male Connector
– O/D tube to
male thread
p. FIT-5-5

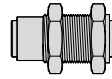

29 Bulkhead Union
– O/D tube to
O/D tube
p. FIT-5-5

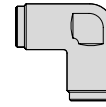

40 Union Elbow
– O/D tube to
O/D tube
p. FIT-5-5

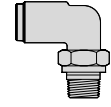

47 Swivel Male Elbow –
O/D tube to male
thread
p. FIT-5-6

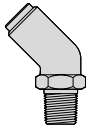

57 Swivel 45° Male Elbow
– O/D tube to male
thread
p. FIT-5-6

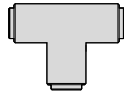

60 Union Tee
– O/D tube
p. FIT-5-5

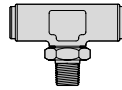

**67 Swivel Male Branch
Tee** – O/D (2) tube to
male thread
p. FIT-5-6

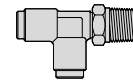

68 Swivel Male Run Tee –
O/D tube (2) to male
thread
p. FIT-5-7

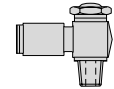

**VB0 Right Angle (Banjo)
Flow Control** – O/D
tube to male thread
p. FIT-5-7

Metric Sizes



20 Union –
– O/D tube to O/D tube
p. FIT-5-8

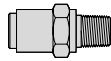

25 Male Connector
O/D tube to male thread
p. FIT-5-8

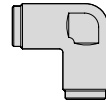

40 Union Elbow
– O/D tube to
O/D tube
p. FIT-5-8

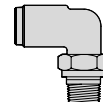

47 Swivel Male Elbow
– O/D tube
to male thread
p. FIT-5-9

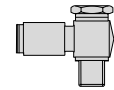

51 Banjo Elbow – O/D
tube to male thread
p. FIT-5-9

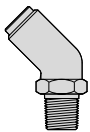

57 Swivel 45° Male Elbow
O/D tube
to male thread
p. FIT-5-9

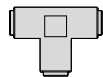

60 Union Tee
– O/D tube
p. FIT-5-8

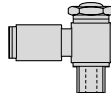

**51 Right Angle (Banjo)
Flow Control** O/D tube
to male thread
p. FIT-5-10



**00 Banjo Bolt
Non Regulating** –
Single Stacking
male thread
p. FIT-5-10

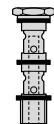

**00 Banjo Bolt
Non Regulating** –
Double Stacking
male thread
p. FIT-5-10



**00 Banjo Bolt
Non Regulating** –
Single Stacking Top
Port male thread
p. FIT-5-10

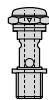

**00 Banjo Bolt
Flow Control** – Single
Stacking male thread
p. FIT-5-11



51 Elbow Banjo Body
– O/D Tube
p. FIT-5-11

Installation

Tube Connection / Disconnection

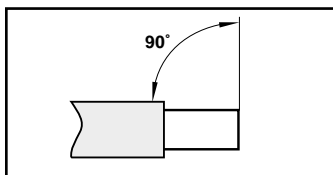

1. Ensure that the end of the tube is cut square and is free from burrs. Correct length of inner tube must be exposed. See FIT-5-14 for details of tube preparation.

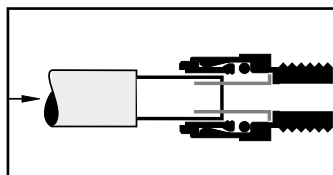

2. Push the tube through the collet into the fitting.

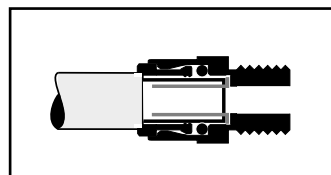

3. Continue pushing the tube through the "O" ring until it bottoms on the tube stop. Then pull back on the tube to reinforce the collet teeth gripping action.

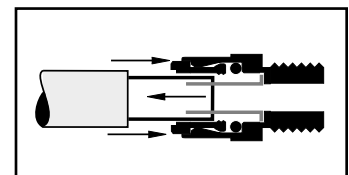

4. To disconnect - First ensure there is no air present. Push the tube into the fitting until it bottoms on the tube stop. Then hold down the collet and withdraw the tube.

WeldFit Push-in Fittings

1/4" to 1/2", and 6 mm – 12 mm Tube Sizes
1/8 to 1/2 NPT and ISO G Thread Options

- Easy tube insertion for rapid assembly of pneumatic & water circuits
- Silicone free 'O' rings
- All metal construction
- Compact
- Nickel plated to reduce weld spatter adherence
- Provides system protection from weld spatter when combined with WeldTube
- Tube support provides high pull out loads
- Easy to disassemble, enables quick re-tubing of system
- Counterbored collet head provides complete protection to inner tube even when side loads are applied to the tubing connection



Specifications

Fluid: Compressed air, water, nitrogen, inert and non-combustible gases compatible with materials of construction.

Note: For other types of fluids or compressed gases, please consult factory.

Working Pressure: 29.5" Hg vacuum to 260 psig (750 mm Hg to 18 bar)
Flow Control working pressures: 5 to 150 psig (.3 to 10 bar)

Note: Working pressure of the fitting/tubing assembly is limited by the working pressure of WeldTube, which is impacted by temperature.

Working Temperature: -20°F to 160°F (-30°C to 70°C) - Limited by working temperature range of WeldTube

Materials

Body, banjo bolt, banjo body, and collet – Nickel plated brass

Tube support – Copper plated brass

Tapered adjusting needle – brass

O-rings and check seal – Silicone free Nitrile

Sealing washer – Thermoplastic (ISO G threads)

Thread Sealant – Precote 5 thread sealant is factory applied to the circumference of tapered male threads.

Tubing:

To be used in conjunction with WeldTube (reference pages FIT-5-12 & 13)

Inch Sizes:

1/4", 3/8", 1/2" O/D tube

1/8, 1/4, 3/8, 1/2 NPT threads

Metric Sizes

6, 8, 10, and 12 mm O/D tube

1/8, 1/4, 3/8, and 1/2 ISO G threads

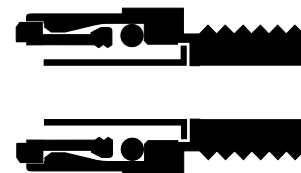



Union

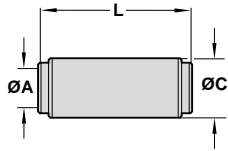

A Tube O/D	Part Number	C	L
1/4"	33 020 0400	0.51 (13.0)	1.40 (35.6)
3/8"	33 020 0600	0.67 (17.0)	1.74 (44.1)
1/2"	33 020 0700	0.81 (20.5)	2.01 (51.1)

Bulkhead Union

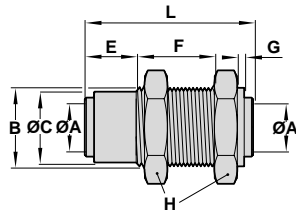

A Tube O/D	Part Number	B Metric Thread	C	L	E	F Max	G Min	H A/F
1/4"	33 029 0400	M15 x 1.0	-	1.41 (35.9)	-	0.87 (22)	0.08 (2)	7/8 (22)
3/8"	33 029 0600	M20 x 1.5	0.70 (17.7)	1.75 (44.5)	0.33 (8.5)	0.87 (22)	0.08 (2)	1-1/16 (27)
1/2"	33 029 0700	M24 x 1.5	0.85 (21.7)	2.02 (51.4)	0.63 (16.0)	0.87 (22)	0.08 (2)	1-3/16 (30)

Union Elbow

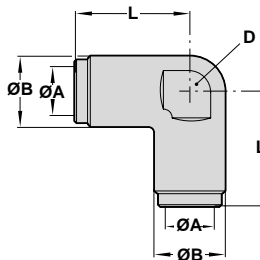

A Tube O/D	Part Number	B	L	D A/F
1/4"	33 040 0400	0.51 (13.0)	0.83 (21.0)	0.37 (9.5)
3/8"	33 040 0600	0.67 (17.0)	1.07 (27.1)	0.52 (13.3)
1/2"	33 040 0700	0.80 (20.5)	1.26 (32.1)	0.63 (16.0)

Union Tee (O/D tube to O/D tube)

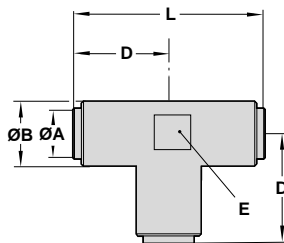

A Tube O/D	Part Number	B	L	D	E A/F
1/4"	33 060 0400	0.51 (13.0)	1.65 (42.0)	0.83 (21.0)	0.37 (9.5)
3/8"	33 060 0600	0.67 (17.0)	2.13 (54.2)	1.07 (27.1)	0.52 (13.3)
1/2"	33 060 0700	0.80 (20.5)	2.53 (64.2)	1.26 (32.1)	0.63 (16.0)

Male Connector

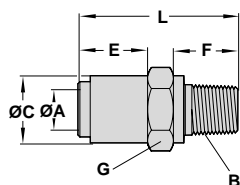

A Tube O/D	B NPT Thread	Part Number	C	L	E	F	G A/F
1/4"	1/8	33 425 0418	0.50 (12.7)	1.04 (26.3)	0.43 (10.8)	0.37 (9.5)	1/2
1/4"	1/4	33 425 0428	0.50 (12.7)	1.17 (29.8)	0.37 (9.3)	0.56 (14.3)	9/16
1/4"	3/8	33 425 0438	0.50 (12.7)	1.20 (30.5)	0.31 (8.0)	0.56 (14.3)	11/16
3/8"	1/4	33 425 0628	0.65 (16.5)	1.48 (37.6)	0.63 (16.1)	0.56 (14.3)	11/16
3/8"	3/8	33 425 0638	0.65 (16.5)	1.42 (36.1)	0.54 (13.6)	0.56 (14.3)	11/16
3/8"	1/2	33 425 0648	0.65 (16.5)	1.46 (37.1)	0.36 (9.1)	0.75 (19.0)	7/8
1/2"	1/4	33 425 0728	0.79 (20.0)	1.68 (42.6)	0.75 (19.1)	0.56 (14.3)	7/8
1/2"	3/8	33 425 0738	0.79 (20.0)	1.64 (41.6)	0.71 (18.1)	0.56 (14.3)	7/8
1/2"	1/2	33 425 0748	0.79 (20.0)	1.72 (43.6)	0.61 (15.6)	0.75 (19.0)	7/8



WeldFit Inch Push-In Fittings

All Dimensions in Inches (mm)

Swivel Male Elbow

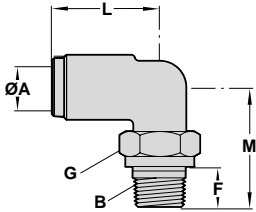

A Tube O/D	B NPT Thread	Part Number	C	L	M	F	G A/F
1/4"	1/8	33 447 0418	0.51 (13.0)	0.83 (21.2)	0.91 (23.2)	0.37 (9.5)	7/16 (11.0)
1/4"	1/4	33 447 0428	0.51 (13.0)	0.83 (21.2)	1.12 (28.4)	0.56 (14.3)	9/16 (14.0)
1/4"	3/8	33 447 0438	0.59 (15.0)	0.85 (21.5)	1.25 (31.7)	0.56 (14.3)	3/4 (19.0)
3/8"	1/4	33 447 0628	0.67 (17.0)	1.07 (27.3)	1.29 (32.7)	0.56 (14.3)	3/4 (19.0)
3/8"	3/8	33 447 0638	0.67 (17.0)	1.07 (27.3)	1.24 (31.6)	0.56 (14.3)	3/4 (19.0)
3/8"	1/2	33 447 0648	0.67 (17.0)	1.07 (27.3)	1.45 (36.8)	0.75 (19.0)	7/8 (22.0)
1/2"	3/8	33 447 0738	0.81 (20.6)	1.27 (32.3)	1.42 (36.1)	0.56 (14.3)	7/8 (22.0)
1/2"	1/2	33 447 0748	0.81 (20.6)	1.27 (32.3)	1.62 (41.1)	0.75 (19.0)	7/8 (22.0)

CAUTION: Swivel adapters are not suitable for use in continuously rotating or gyrating applications.

Swivel 45° Male Elbow

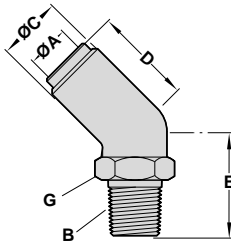

A Tube O/D	B NPT Thread	Part Number	C	D	E	F	G A/F
1/4"	1/8	33 457 0418	0.51 (13.0)	0.76 (19.3)	0.74 (18.9)	0.37 (9.5)	7/16 (11.0)
1/4"	1/4	33 457 0428	0.51 (13.0)	0.76 (19.3)	0.95 (24.1)	0.56 (14.3)	9/16 (14.0)
3/8"	1/4	33 457 0628	0.70 (17.7)	0.94 (23.8)	1.08 (27.4)	0.56 (14.3)	3/4 (19.0)
3/8"	3/8	33 457 0638	0.70 (17.7)	0.94 (23.8)	1.17 (29.8)	0.56 (14.3)	3/4 (19.0)
1/2"	1/2	33 457 0748	0.91 (23.2)	1.27 (32.3)	1.43 (36.4)	0.75 (19.0)	7/8 (22.0)

CAUTION: Swivel adapters are not suitable for use in continuously rotating or gyrating applications.

Swivel Male Branch Tee

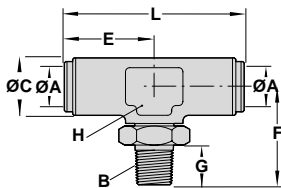

A Tube O/D	B NPT Thread	Part Number	C	L	E	F	G	H A/F
1/4"	1/8	33 467 0418	0.51 (13.0)	1.67 (42.4)	0.83 (21.2)	0.87 (22.2)	0.37 (9.5)	7/16 (11.0)
1/4"	1/4	33 467 0428	0.51 (13.0)	1.67 (42.4)	0.83 (21.2)	1.10 (28.1)	0.56 (14.3)	9/16 (14.0)
1/4"	3/8	33 467 0438	0.59 (15.0)	1.67 (42.4)	0.83 (21.2)	1.16 (29.4)	0.56 (14.3)	3/4 (19.0)
3/8"	1/4	33 467 0628	0.67 (17.0)	2.17 (55.0)	1.08 (27.5)	1.27 (32.4)	0.56 (14.3)	3/4 (19.0)
3/8"	3/8	33 467 0638	0.67 (17.0)	2.17 (55.0)	1.08 (27.5)	1.22 (31.1)	0.56 (14.3)	3/4 (19.0)
3/8"	1/2	33 467 0648	0.67 (17.0)	2.17 (55.0)	1.08 (27.5)	1.44 (36.6)	0.75 (19.1)	7/8 (22.0)
1/2"	1/4	33 467 0728	0.81 (20.6)	2.56 (65.0)	1.28 (32.5)	1.35 (34.4)	0.56 (14.3)	7/8 (22.0)
1/2"	3/8	33 467 0738	0.81 (20.6)	2.56 (65.0)	1.28 (32.5)	1.39 (35.3)	0.56 (14.3)	7/8 (22.0)
1/2"	1/2	33 467 0748	0.81 (20.6)	2.56 (65.0)	1.28 (32.5)	1.58 (40.3)	0.75 (19.1)	7/8 (22.0)

CAUTION: Swivel adapters are not suitable for use in continuously rotating or gyrating applications.



Swivel Male Run Tee

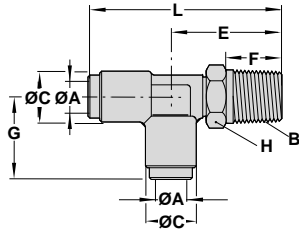

A Tube O/D	B NPT Thread	Part Number	C	L	E	F	G	H A/F
1/4"	1/8	33 468 0418	0.51 (13.0)	1.75 (44.4)	0.90 (22.8)	0.37 (9.5)	0.83 (21.2)	7/16 (11.0)
1/4"	1/4	33 468 0428	0.51 (13.0)	1.95 (49.6)	1.10 (28.1)	0.56 (14.3)	0.83 (21.2)	9/16 (14.0)
1/4"	3/8	33 468 0438	0.51 (13.0)	2.08 (52.9)	1.23 (31.4)	0.56 (14.3)	0.84 (21.3)	3/4 (19.0)
3/8"	1/4	33 468 0628	0.67 (17.0)	2.36 (60.0)	1.27 (32.2)	0.56 (14.3)	1.07 (27.3)	3/4 (19.0)
3/8"	3/8	33 468 0638	0.67 (17.0)	2.32 (58.9)	1.22 (31.1)	0.56 (14.3)	1.07 (27.3)	3/4 (19.0)
3/8"	1/2	33 468 0648	0.67 (17.0)	2.52 (64.1)	1.44 (36.6)	0.75 (19.1)	1.07 (27.3)	7/8 (22.0)
1/2"	1/4	33 468 0728	0.81 (20.6)	2.54 (64.5)	1.35 (34.4)	0.56 (14.3)	1.27 (32.3)	7/8 (22.0)
1/2"	3/8	33 468 0738	0.81 (20.6)	2.69 (68.4)	1.39 (35.3)	0.56 (14.3)	1.27 (32.3)	7/8 (22.0)
1/2"	1/2	33 468 0748	0.81 (20.6)	2.89 (73.4)	1.60 (40.8)	0.75 (19.1)	1.27 (32.3)	7/8 (22.0)

CAUTION: Swivel adapters are not suitable for use in continuously rotating or gyrating applications.

Right Angle (Banjo) Flow Control (Meter Out)

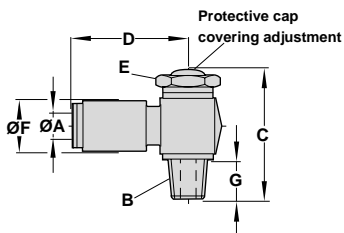

A Tube O/D	B NPT Thread	Part Number	C	D	E A/F	F	G
1/4"	1/8	33 VB0 0418	1.57 (40.0)	0.98 (24.8)	9/16	0.63 (16)	0.37 (9.5)
1/4"	1/4	33 VB0 0428	1.83 (46.5)	1.06 (26.8)	3/4	0.79 (20)	0.56 (14.3)
3/8"	1/4	33 VB0 0628	1.83 (46.5)	1.22 (31.0)	3/4	0.79 (20)	0.56 (14.3)
3/8"	3/8	33 VB0 0638	2.22 (56.5)	1.30 (33.0)	7/8	0.94 (24)	0.56 (14.3)
1/2"	1/2	33 VB0 0748	2.56 (65.0)	1.58 (40.2)	11/16	1.18 (30)	0.75 (19.0)

Note: For flow performance see graphs on page FIT-3-5 for 12 VB0 series.
Working pressure: 5 to 150 psig (.3 to 10 bar)



WeldFit Metric Push-In Fittings

All Dimensions in MM (inches)

Union

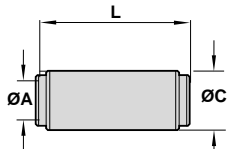

A Tube O/D	Part Number	C	L
6	21 020 0600	13 (0.51)	40 (1.57)
8	21 020 0800	15 (0.59)	42 (1.65)
10	21 020 1000	17 (0.67)	48.7 (1.92)
12	21 020 1200	20.5 (0.81)	56.1 (2.21)

Union Elbow

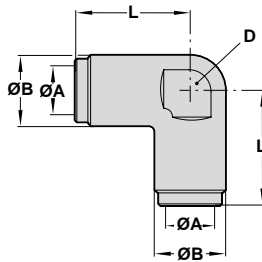

A Tube O/D	Part Number	B	L	D A/F
6	21 040 0600	13	23 (0.91)	9.5 (0.37)
8	21 040 0800	15	25 (0.98)	11.0 (0.43)
10	21 0400 1000	17	29 (1.14)	13.3 (0.52)
12	21 0400 1200	20.5	35 (1.38)	16 (0.63)

Union Tee

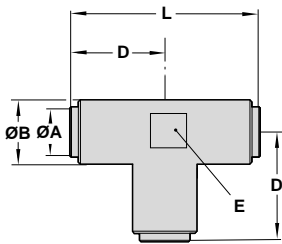

A Tube O/D	Part Number	B	L	D	E A/F
6	21 060 0600	13	46 (1.81)	23 (0.91)	9.5 (0.37)
8	21 060 0800	15	50 (1.97)	25 (0.98)	11.0 (0.43)
10	21 060 1000	17	59 (2.32)	29 (1.14)	13.3 (0.52)
12	21 060 1200	20.5	69 (2.72)	35 (1.38)	16.0 (0.63)

Male Connector

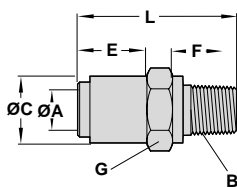

A Tube O/D	B ISO G Thread	Part Number	C	L	E	F	G A/F
6	1/8	21 225 0618	12.7 (0.50)	28 (1.10)	14 (0.55)	7.2 (0.28)	14 (0.55)
6	1/4	21 225 0628	12.7 (0.50)	29 (1.14)	10 (0.39)	9.8 (0.39)	19 (0.75)
8	1/8	21 225 0818	14.7 (0.58)	30 (1.18)	16 (0.63)	7.2 (0.28)	15 (0.59)
8	1/4	21 225 0828	14.7 (0.58)	32 (1.26)	13 (0.51)	9.8 (0.39)	19 (0.75)
8	3/8	21 225 0838	14.7 (0.58)	27 (1.06)	7 (0.28)	11.2 (0.44)	22 (0.87)
8	1/2	21 225 0848	14.7 (0.58)	35 (1.38)	7 (0.28)	14.8 (0.58)	27 (1.06)
10	1/4	21 225 1028	16.5 (0.65)	36 (1.42)	17 (0.67)	9.8 (0.39)	19 (0.75)
10	3/8	21 225 1038	16.5 (0.65)	36 (1.42)	14 (0.55)	11.2 (0.44)	22 (0.87)
10	1/2	21 225 1048	16.5 (0.65)	35 (1.38)	7 (0.28)	14.8 (0.58)	27 (1.06)
12	3/8	21 225 1238	20 (0.79)	41 (1.61)	20 (0.79)	11.2 (0.44)	22 (0.87)
12	1/2	21 225 1248	20 (0.79)	40 (1.57)	13 (0.51)	14.8 (0.58)	27 (1.06)

Supplied with sealing washer



Swivel Elbow Adaptors

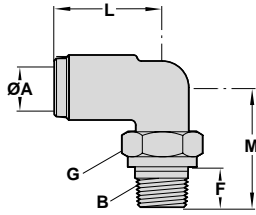

A Tube O/D	B ISO G Thread	Part Number	L	M	F	G A/F
6	1/8	21 247 0618	23 (0.91)	23.2 (0.91)	7.2 (0.28)	15 (0.59)
6	1/4	21 247 0628	23 (0.91)	28.5 (1.12)	9.8 (0.39)	19 (0.75)
8	1/8	21 247 0818	25 (0.98)	24.2 (0.95)	7.2 (0.28)	15 (0.59)
8	1/4	21 247 0828	25 (0.98)	30.3 (1.19)	9.8 (0.39)	19 (0.75)
8	3/8	21 247 0838	27 (1.06)	33.8 (1.33)	11.2 (0.44)	22 (0.87)
8	1/2	21 247 0848	27 (1.06)	39.3 (1.55)	14.75 (0.58)	27 (1.06)
10	1/8	21 247 1018	30 (1.18)	26.2 (1.03)	7.2 (0.28)	15 (0.59)
10	1/4	21 247 1028	30 (1.18)	31.0 (1.22)	9.8 (0.39)	19 (0.75)
10	3/8	21 247 1038	30 (1.18)	33.8 (1.33)	11.2 (0.44)	22 (0.87)
10	1/2	21 247 1048	30 (1.18)	39.3 (1.55)	14.75 (0.58)	27 (1.06)
12	1/4	21 247 1228	35 (1.38)	33.4 (1.31)	9.8 (0.39)	19 (0.75)
12	3/8	21 247 1238	35 (1.38)	37.8 (1.49)	11.2 (0.44)	22 (0.87)
12	1/2	21 247 1248	35 (1.38)	43.3 (1.70)	14.75 (0.58)	27 (1.06)

Supplied with sealing washer

CAUTION: Swivel adapters are not suitable for use in continuously rotating or gyrating applications.

Banjo Elbow Assembly

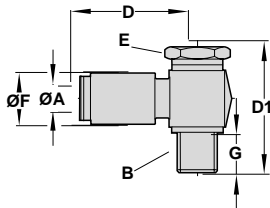

A Tube O/D	B ISO G Thread	Part Number	D	D1	E A/F	F	G
6	1/8	21 A51 0618	29 (1.14)	29 (1.14)	14 (0.55)	12 (0.47)	5 (0.20)
6	1/4	21 A51 0628	28 (1.10)	32 (1.26)	17 (0.67)	13 (0.51)	6 (0.24)
8	1/4	21 A51 0828	29 (1.14)	32 (1.26)	17 (0.67)	15 (0.59)	6 (0.24)
8	3/8	21 A51 0838	31 (1.22)	46 (1.81)	22 (0.87)	15 (0.59)	9 (0.35)
10	3/8	21 A51 1038	35 (1.38)	46 (1.81)	22 (0.87)	15 (0.59)	9 (0.35)
12	3/8	21 A51 1238	38 (1.50)	46 (1.81)	22 (0.87)	20 (0.79)	9 (0.35)
10	1/2	21 A51 1048	38 (1.50)	48 (1.89)	27 (1.06)	17 (0.67)	13 (0.51)
12	1/2	21 A51 1248	41 (1.61)	48 (1.89)	27 (1.06)	20 (0.79)	13 (0.51)

Supplied with sealing washer

Swivel 45° Male Elbow Adaptor

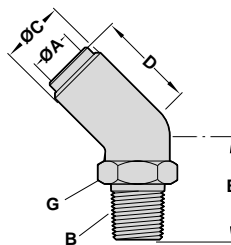

A Tube O/D	B ISO G Thread	Part Number	C	D	E	G A/F
6	1/8	21 257 0618	13 (0.51)	22 (0.87)	19.2 (0.76)	15 (0.59)
6	1/4	21 257 0628	13 (0.51)	22 (0.87)	24.5 (0.96)	19 (0.75)
8	1/8	21 257 0818	15 (0.59)	23 (0.91)	20.5 (0.81)	15 (0.59)
8	1/4	21 257 0828	15 (0.59)	23 (0.91)	25.8 (1.02)	19 (0.75)
10	1/8	21 257 1018	17 (0.67)	27 (1.06)	21 (0.83)	15 (0.59)

Supplied with sealing washer

CAUTION: Swivel adapters are not suitable for use in continuously rotating or gyrating applications.



WeldFit Metric Push-In Fittings

All Dimensions in MM (inches)

Right Angle (Banjo) Flow Control (Meter Out)

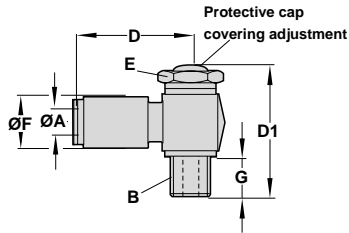

A Tube O/D	B ISO G Thread	Part Number	D	D1	E A/F	F	G
6	1/8	21 K51 0618	28 (1.10)	34 (1.34)	13 (0.51)	13 (0.51)	6 (0.24)
6	1/4	21 K51 0628	28 (1.10)	36.5 (1.44)	17 (0.67)	13 (0.51)	6 (0.24)
8	1/4	21 K51 0828	29 (1.14)	36.5 (1.44)	17 (0.67)	15 (0.59)	6 (0.24)
8	3/8	21 K51 0838	31 (1.22)	51.5 (2.03)	22 (0.87)	15 (0.59)	10 (0.39)
10	3/8	21 K51 1038	38 (1.50)	51.5 (2.03)	22 (0.87)	17 (0.67)	10 (0.39)
12	1/2	21 K51 1248	41 (1.61)	57.5 (2.26)	27 (1.06)	20 (0.79)	12 (0.47)

Working pressure: 0.3 to 10 bar (5 - 150 psig)

Supplied complete with sealing washers.

NOTE: For flow performance see graphs on page FIT-3-5 for 10K51 series.

Banjo Bolt – Non Regulating (Single Stacking)

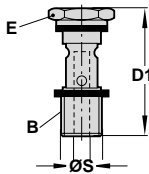

B ISO G or metric Thread	Part Number	D1	E A/F	S
M5 x 0.8	20 A00 0005	22 (0.87)	8 (0.31)	2.5 (0.10)
1/8	20 A00 0018	30 (1.18)	14 (0.55)	5 (0.20)
1/4	20 A00 0028	34 (1.34)	17 (0.67)	8.5 (0.33)
3/8	20 A00 0038	41 (1.61)	22 (0.87)	10 (0.39)
1/2	20 A00 0048	47.5 (1.87)	27 (1.06)	11.5 (0.45)

Supplied complete with sealing washers.

Banjo Bolt – Non Regulating (Double Stacking)

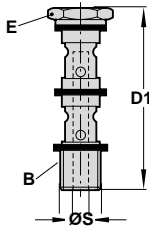

B ISO G or metric Thread	Part Number	D1	E A/F	S
M5x0.8	20 B00 0005	34.5 (1.36)	8 (0.31)	2.5 (0.10)
1/8	20 B00 0018	46.5 (1.83)	14 (0.55)	5 (0.20)
1/4	20 B00 0028	52.5 (2.07)	17 (0.67)	8.5 (0.33)
3/8	20 B00 0038	64 (2.52)	22 (0.87)	10 (0.39)
1/2	20 B00 0048	72.5 (2.85)	27 (1.06)	11.5 (0.45)

Supplied complete with sealing washers.

Banjo Bolt – Non Regulating (Single Stacking with Top Port)

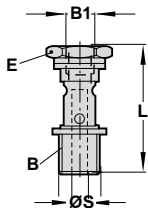

B ISO G or metric Thread	B1 ISO G or metric Thread	Part Number	L	E A/F	ØS
M5x0.8	M5x0.8	20 D00 0505	25.6 (1.01)	8 (0.31)	2.5 (0.10)
M5x0.8	1/4	20 D00 0528	34 (1.34)	17 (0.67)	8.5 (0.33)
M5x0.8	3/8	20 D00 0538	41 (1.61)	22 (0.87)	10 (0.39)
1/8	1/8	20 E00 1818	36 (1.42)	14 (0.55)	5 (0.20)
1/8	1/4	20 E00 1828	35.5 (1.40)	17 (0.67)	6 (0.24)
1/8	3/8	20 E00 1838	41 (1.61)	22 (0.87)	10 (0.39)
1/4	1/4	20 F00 2828	45 (1.77)	17 (0.67)	8.5 (0.33)

Supplied complete with sealing washers.



Elbow Banjo Body

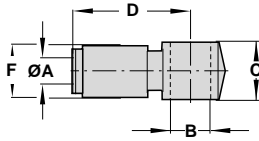

A Tube O/D	B ISO G or metric Thread	Part Number	C	D	F
6	M5	21 051 0605	12.6 (0.50)	25 (0.98)	12.3 (0.48)
6	1/8	21 051 0618	14 (0.55)	28 (1.10)	13 (0.51)
6	1/4	21 051 0628	16 (0.63)	29 (1.14)	13 (0.51)
8	1/4	21 051 0828	16 (0.63)	29 (1.14)	15 (0.59)
8	3/8	21 051 0838	20.5 (0.81)	31 (1.22)	15 (0.59)
10	3/8	21 051 1038	20.5 (0.81)	35 (1.38)	17 (0.67)
12	3/8	21 051 1238	20.5 (0.81)	38 (1.50)	20 (0.79)
10	1/2	21 051 1048	22 (0.87)	38 (1.50)	17 (0.67)
12	1/2	21 051 1248	22 (0.87)	41 (1.61)	20 (0.79)

Banjo Bolt – Flow Control (Single Stacking)

20*00

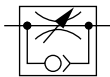
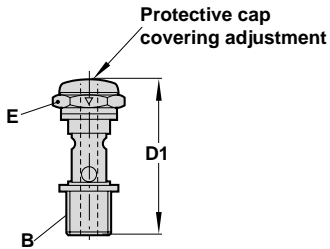

Meter In

B ISO G or metric Thread	Part Number	D1	E A/F
M5x0.8	20 K00 0005	27.3 (1.07)	8 (0.31)
1/8	20 K00 0018	34 (1.34)	14 (0.55)
1/4	20 K00 0028	36.5 (1.44)	17 (0.67)
3/8	20 K00 0038	51.5 (2.03)	22 (0.87)
1/2	20 K00 0048	57 (2.24)	27 (1.06)

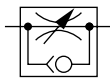

Meter Out

B ISO G or metric Thread	Part Number	D1	E A/F
M5x0.8	20 L00 0005	27.3 (1.07)	8 (0.31)
1/8	20 L00 0018	34 (1.34)	14 (0.55)
1/4	20 L00 0028	36.5 (1.44)	17 (0.67)
3/8	20 L00 0038	51.5 (2.03)	22 (0.87)

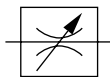

Bi-Directional

B ISO G or metric Thread	Part Number	D1	E A/F
M5x0.8	20 M00 0005	27.3 (1.07)	8 (0.31)
1/8	20 M00 0018	34 (1.34)	14 (0.55)
1/4	20 M00 0028	36.5 (1.44)	17 (0.67)
3/8	20 M00 0038	51.5 (2.03)	22 (0.87)
1/2	20 M00 0048	57 (2.24)	27 (1.06)

All banjo bolts supplied complete with sealing washers.
 Arrow on bolt hexagon indicates free flow direction.
 Working pressure: .3 - 10 bar (5 - 150 psig)

- Available in a variety of colors in three inch and four metric sizes
- Outer jacket protects against damage from weld spatter
- Designed to be used with WeldFit push-in fittings
- Good flexibility with tight bend radius capability
- Good chemical resistance
- Flame retardant outer jacket

**Specifications****Fluid**

Compressed air, water, nitrogen, inert and non-combustible gases compatible with materials of construction.

Note: For other types of fluids or compressed gases, please consult factory.

Working Pressure

Inch - 28" Hg vacuum to 145 psig (711 mm Hg to 10 bar)

Metric - 750 mm Hg vacuum to 10 bar (729.5" Hg vacuum to 145 psig)

Note: Working pressures are temperature limited, see chart and graph, FIT-5-13.

Working Temperature

Inch: -40°F to 165°F (-40°C to 74°C)

Metric: -30°C to 70°C (-22°F to 158°F)

Diameter Tolerance

Inch: ± 0.005 " inner tube OD

Materials

Inner tube - Polyurethane, 95° shore A

Inner tube colors: inch - blue

metric - green

Jacket

Inch Thermoplastic rubber (meets UL 94VO requirements)

Metric - Flame retardant PVC

Tubing Sizes

Inch -

1/4", 3/8", 1/2" OD

Metric -

6, 8, 10, and 12 mm OD



Inch Weld Tube

OD Inner Tube	ID Inner Tube	Jacket Thickness (ref.)	Working Pressure		Bend Radius	Part Number and Jacket Color				
			@ 75°F	@ 150°F		Black	Red	Green	Blue	White
			psi. (bar)	psi.(bar)						
1/4"	0.160"	0.030"	148 (10.2)	74 (5.1)	1/2"(13)	WT 4754 100	WT 4154 100	WT 4254 100	WT 4554 100	WT 4054 100
3/8"	0.245"	0.030"	147 (10.1)	74 (5.1)	7/8"(22)	WT 4756 100	WT 4156 100	WT 4256 100	WT 4556 100	WT 4056 100
1/2"	0.320"	0.030"	140 (9.7)	70 (4.8)	1-1/8"(29)	WT 4757 100	WT 4157 100	WT 4257 100	WT 4557 100	WT 4057 100

Notes

The working pressure for the inner polyurethane tube is calculated using a 3 to 1 safety factor.
 To determine working pressures at other temperatures, see chart.
 Tubing is supplied in 100 ft. (30.5m) coils, packaged in poly bags.
 For other colors, lengths or packaging, please consult factory.

Metric Weld Tube

OD Inner Tube	ID Inner Tube	OD Jacket (ref.)	Working Pressure		Bend Radius	Part Number and Jacket Color			
			@ 75°F	@ 150°F		Black	Red	Green	Blue
			bar (psi)	bar (psi)					
6	4	8	10 (145)	5 (73)	40 (1.6)	WT 4706 025	WT 4106 025	WT 4206 025	WT 4506 025
8	6	10	10 (145)	5 (73)	50 (2.0)	WT 4708 025	WT 4108 025	WT 4208 025	WT 4508 025
10	7	12.5	10 (145)	5 (73)	65 (2.6)	WT 4710 025	WT 4110 025	WT 4210 025	WT 4510 025
12	9	14.5	10 (145)	5 (73)	75 (3.0)	WT 4712 025	WT 4112 025	WT 4212 025	WT 4512 025

Notes

The working pressure for the inner polyurethane tube is calculated using a 3 to 1 safety factor.
 To determine working pressures at other temperatures, see chart.
 Tubing is supplied in 25 meter (82 ft.) coils, packaged in poly bags.
 For other colors, lengths or packaging, please consult factory.

Working Pressure at Elevated Temperature

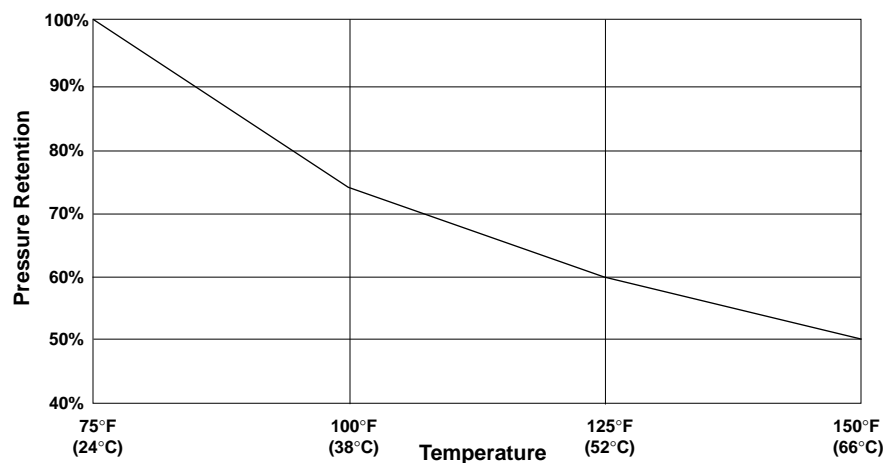



WeldTube

All Dimensions in Inches (mm)

WeldTube Jacket Stripper

- Facilitates stripping of WeldTube's jacket from inner tube
- Operates in the same fashion as a cable jacket stripper

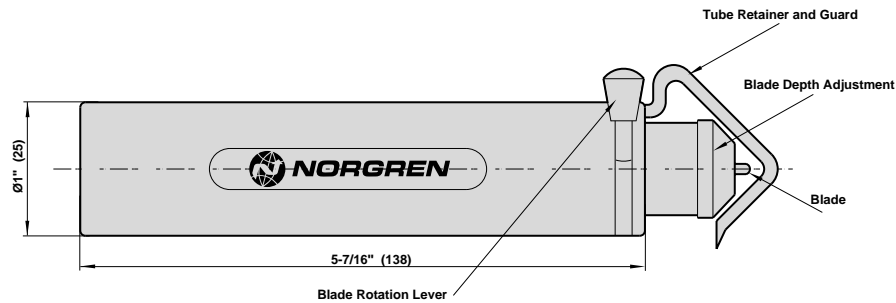

Description	Part Number
Jacket Stripper	39004100
Spare Blades - 2 pcs.	39004160

To obtain optimum protection from weld splatter, the outer tube jacket needs to be removed, exposing the correct length of inner tube for insertion into the tube gland of the WeldFit fitting. The outer jacket fits into the collet counterbore, thus providing optimal system protection from weld splatter.

The jacket does not adhere to the inner tube, thus it can be slit and removed to provide the correct length of inner tube for insertion into the fitting. When slitting the jacket, care should be taken not to score the inner tube. The featured WeldTube Jacket Stripper has been designed and is recommended for this task.

Procedure

1. Using a standard tube cutter, cut completely through the tube. The cut must be made in the middle of one of the \times marks found along the tube's centerline. Ensure the tube is cut at 90° to its axis.
2. Cutter depth adjustment: Rotate the head (threaded adjustment) to adjust the depth of cut to just equal jacket thickness.
3. Push open the tube retainer and guard (spring loaded) and insert the tube to be stripped. Line up the blade of the WeldTube Jacket Stripper with the next \times mark from the tube end. This ensures that the correct length of jacket will be stripped off. Release the guard, which will now retain the tube.
4. To cut through the outer jacket, rotate the cutter around the circumference of the tube.
5. Engage the blade rotation lever, pushing it up against its stop and holding it in this position. This pivots the blade 90°. Pull the Jacket Stripper longitudinally along the length of the jacket segment to be removed. The rotated blade will slit the jacket segment along its length.
6. The outer jacket segment can now be removed. The ground edge of the guard can be used to assist in accomplishing this.
7. The tube is ready for insertion into its WeldFit fitting.

Cartridge Fittings



FleetFit D.O.T. Cartridge FittingsFIT-6-2
FleetFit D.O.T. Cartridge Fittings Assembly InstructionsFIT-6-3
Pneufit Inch and Metric Cartridge Industrial FittingsFIT-6-4
Pneufit Inch Cartridge Assembly InstructionsFIT-6-5
Pneufit Metric Cartridge Assembly InstructionsFIT-6-7

- Combined retention barb and pressure ridge provides a fitting that can be used in both plastic and metal substrates
- External o-ring's location ahead of retention results in a positive bore seal before any deformation or bore scoring occurs
- Reduced assembly times, above and beyond the benefit delivered by FleetFit Push-In fittings alone
- Reduces costly rework from cross threading, over/under torquing, and clocking errors, while eliminating the spiral leakage associated with threaded ports on air brake and auxiliary system air components
- Virtually eliminates secondary port threading operations and the difficulties associated with threads in various substrates
- No tools required to install fittings or tubing into components incorporating cartridges
- Optional color coded collet caps substantially reduce assembly errors and rework
- Tubes may be reconnected numerous times without compromising sealing integrity between the tube to fitting connection



Technical Data

Operating Medium:
Compressed air

Maximum Working Pressure:
0 to 150 psi (0-10 bar)

Working Temperature:
-40°F to 212°F (-40°C to 100°C)

Materials

Body, Collet and Tube Support: Brass BS 2874 CZ 121

Internal and external O-rings: Buna N (Low Nitrile)

Applications

Gland dimensions and insertion forces differ slightly between metal and composite substrates.

For further details, please consult our Technical Services Department.

FleetFit full-bodied cartridges comply with the currently evolving SAE Cartridge Performance Specification as defined by the Push-to-connect Task Force of the FCCTC SC4 Committee.

Tubing

Tube should be to the following standards.

INCH SAE J844

METRIC DIN 74324, ISO 7628, NFR 12-632

Installation Procedure

Assembly Instructions

1. Ensure all parts are clean.
2. Lubricate outer O-ring with appropriate medium grade grease (BP Energol LS2) is recommended.
3. Locate correct end of cartridge body in port form. Then, using a recessed form tool (see table for details) apply an axial load to press in cartridge body until flush with outside surface. Minimum loads should be used to avoid damage to cartridge flange and face of component.

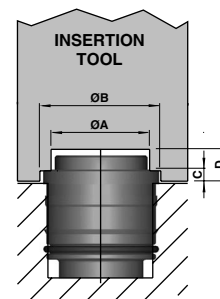

Cartridge Size	A	B	C	D
5/32"	.33 (9)	.47 (12)	.06 (2)	.20 (5)
3/16"	.43 (11)	.51 (13)	.06 (2)	.22 (6)
1/4"	.47 (12)	.59 (15)	.05 (1)	.22 (6)
3/8"	.61 (16)	.75 (19)	.06 (2)	.24 (6)
1/2"	.75 (19)	.89 (23)	.09 (2)	.26 (7)
5/8"	.94 (24)	1.06 (27)	.13 (3)	.27 (7)
3/4"	1.04 (27)	1.22 (31)	.14 (4)	.31 (8)

D.O.T Cartridges for Industrial Applications



Dimensions in mm (inches)

NOTE: Inch equivalents are for reference only.

Port Forms

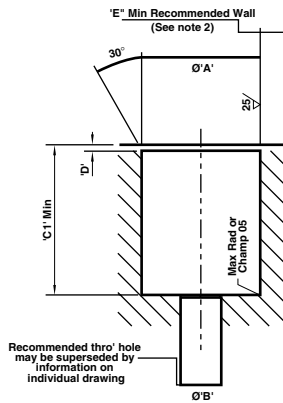

SAE Port Size	Ø 'A' Plastic	Ø 'A' Metal	Ø 'B'	'C'1 Min	'D' -0.2	'E' Plastic	'E' Metal
5/32"	.344 (8.8) .340 (8.7)	.348 (8.9) .344 (8.8)	.12 (3)	.45 (11)	.03 (.8)	.09 (2)	.06 (2)
3/16"	.380 (9.7) .337 (8.6)	.384 (9.8) .380 (9.7)	.12 (3)	.48 (12)	.03 (.8)	.12 (3)	.08 (2)
1/4"	.502 (12.8) .496 (12.6)	.486 (12.4) .502 (12.8)	.14 (4)	.47 (12)	.03 (.8)	.12 (3)	.08 (2)
3/8"	.648 (16.5) .642 (16.3)	.652 (16.6) .648 (16.5)	.28 (7)	.60 (15)	.03 (.8)	.12 (3)	.08 (2)
1/2"	.774 (19.7) .768 (19.5)	.778 (19.8) .774 (19.7)	.40 (10)	.64 (16)	.03 (.8)	.12 (3)	.08 (2)
5/8"	.921 (23.4) .915 (23.3)	.927 (23.6) .923 (23.5)	.47 (12)	.81 (21)	.03 (.8)	.14 (4)	.10 (3)
3/4"	1.063 (27.0) 1.057 (26.9)	1.069 (27.2) 1.065 (27.1)	.60 (15)	.94 (24)	.03 (.8)	.14 (4)	.10 (3)

Notes:

- These dimensions are recommended for the following materials:
Metal - Aluminum, Zinc, Brass
Plastic - Nylon, Nylon 66, Acetal (In filled or unfilled conditions)
- For use with thinner wall sections than "E" values given consult IMI Norgren
- Dimensions in millimeters

DOT/SAE Standard Cartridge

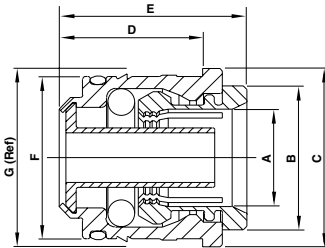

SAE Port Size	Part Number	Dimensions (mm)						
		Tube O/D A	B	C	D	E	F	G (REF)
5/32"	94 4026 02	5/32"	.3 (8)	.43 (11)	.43 (11)	.61 (15)	.338 (8.6)	(9)
							.334 (8.5)	
3/16"	94 4026 03	3/16"	.39 (10)	.47 (12)	.46 (12)	.64 (16)	.374 (9.5)	(10)
							.370 (9.4)	
1/4"	94 4026 04	1/4"	.43 (11)	.55 (14)	.45 (11)	.61 (16)	.494 (12.6)	(13)
							.490 (12.5)	
3/8"	94 4026 06	3/8"	.57 (15)	.71 (18)	.57 (15)	.76 (19)	.640 (16.3)	(17)
							.636 (16.2)	
1/2"	94 4026 07	1/2"	.71 (18)	.85 (22)	.64 (16)	.84 (21)	.766 (19.5)	(20)
							.762 (19.5)	
5/8"	94 4026 08	5/8"	.91 (23)	.98 (25)	.78 (20)	1.02 (26)	.913 (23.2)	(24)
							.909 (23.1)	
3/4"	94 4026 09	3/4"	1 (25)	1.18 (30)	.82 (21)	1.09 (28)	1.055 (26.8)	(28)
							1.051 (26.7)	

DOT/SAE Reducing Cartridge

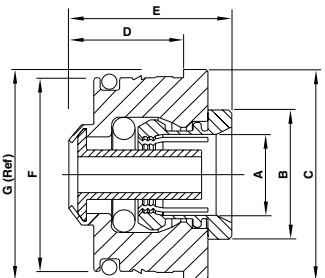

SAE Port Size	Part Number	Dimensions (mm)						
		Tube O/D A	B	C	D	E	F	G (REF)
3/8"	94 4027 48	1/4"	.43 (11)	.71 (18)	.43 (11)	.60 (15)	.646 (16.4)	.67 (17)
							.642 (16.3)	
1/2"	94 4027 64	3/8"	.57 (15)	.85 (22)	.55 (14)	.75 (19)	.764 (19.4)	.80 (20)
							.760 (19.3)	
5/8"	94 4027 71	1/2"	.71 (18)	.98 (25)	.59 (15)	.83 (21)	.921 (23.4)	.95 (24)
							.917 (23.3)	
3/4"	94 4027 79	5/8"	.91 (23)	1.18 (30)	.78 (20)	1.02 (26)	1.039 (26.4)	1.09 (28)
							1.035 (26.3)	

DOT/SAE Expanding Cartridge

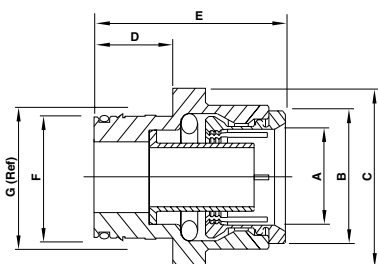

SAE Port Size	Part Number	Dimensions (mm)						
		Tube O/D A	B	C	D	E	F	G (REF)
1/4"	94 4028 48	3/8"	.57 (15)	.75 (19)	.37 (9)	.98 (25)	.502 (12.8)	.52 (13)
							.498 (12.7)	
3/8"	94 4028 64	1/2"	.71 (18)	.94 (24)	.48 (12)	1.15 (29)	.646 (16.4)	.67 (17)
							.642 (16.3)	
1/2"	94 4028 71	5/8"	.91 (23)	1.10 (28)	.51 (13)	1.30 (33)	.764 (19.4)	.80 (20)
							.760 (19.3)	
5/8"	94 4028 79	3/4"	1 (25)	1.26 (32)	.65 (16)	1.52 (39)	.921 (23.4)	.95 (24)
							.917 (23.3)	

Pneufit Inch and Metric Cartridges for Industrial Applications

- Cartridge Fittings provide consistent port-to-port dimensions, a uniform “cutting technology” appearance to products, and promote sales by providing a visible technical advantage.
- The fitting becomes an integral part of the component, eliminating threaded connections and the possibility of spiral leakage along the thread joint.
- By eliminating the tightening of compression nuts, they allow for more compact assemblies, reduce worker fatigue and provide substantially reduced assembly times.
- Insertion gland configurations can be molded or machined directly into plastic or metal products (via a stepped core or form tool), eliminating the need for costly and troublesome secondary threading operations.
- One fitting can be used in both plastic or metal substrates reducing component part inventory requirements. Gland dimensions and insertion techniques differ slightly between plastic and metal substrates.



In addition to incorporating the standard features, benefits and specifications common to the Pneufit line, Cartridge Fittings allow Original Equipment Manufacturers to directly integrate a push-in connection into their product designs. Benefits include the elimination of threaded ports, reduced leakage, a cost effective method of tube connection, compactness, and improved product appearance. Cartridges are provided as a three piece “kit”, consisting of brass body, silicone free O-ring and a nickel plated brass collet, which serves to retain the tube upon assembly. They can be fitted into products made from ferrous or non-ferrous metals and most industrial plastics.

In addition to the standard range of cartridges capable of meeting the majority of applications, specials can be produced to meet particular requirements provided quantities suffice. *Please consult the factory with any special requests.*

Specifications

Fluid: Compressed air, nitrogen, inert and non-combustible gases compatible with materials of construction.

Note: For other types of fluids or compressed gases, please consult factory.

Working Pressure: 29.5" Hg vacuum to 260 psig (750 mm Hg to 18 bar)

Working Temperature: 0° to 175°F (-20° to 80°C)

See Viton® Option for extended temperature range : 0° to 350°F (-20° to 180°C)

Materials

Body – Brass

Collet – Nickel plated brass

O-ring: Silicone free Nitrile

Tubing: Nylon 11 or 12, Polyurethane (95 durometer or above) and LDPE (Low Density Polyethylene).

Note: Lower durometer polyurethane may be used, however, an internal tube support is required to prevent internal collapse of the tube wall.

Pneufit Inch Cartridges for Industrial Applications



Dimensions in Inches (mm)

NOTE: MM equivalents are for reference only.

Assembly instructions for installing cartridges into metal components.

1. Ensure that all parts are clean.
2. Insert the correct end of the cartridge body into the port form (see illustration). Then, using an installation tool as shown in Fig.1, press the cartridge body in until it is flush with the surface while staking it into place (Fig. 3). Minimum loads should be used to avoid damage to the end faces of the cartridge body.
3. Lubricate the O-ring with appropriate medium grade mineral grease (BP Energol LS2). Locate as shown in port.
4. Insert the collet into the body using minimal force.

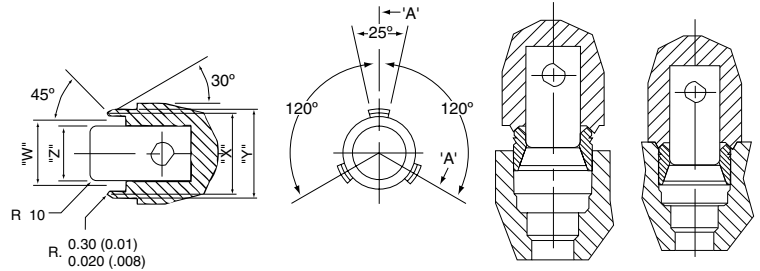

Fig. 1

Fig. 2

Fig. 3

Tube Size	W		Y	
	+0.05 -0.0	X	+0.05 -0.0	Z
1/8"	0.305 (7.75)	0.346 (8.80)	0.400 (10.15)	0.163 (4.15)
5/32"	0.324 (8.25)	0.366 (9.30)	0.420 (10.65)	0.203 (5.15)
3/16"	0.364 (9.25)	0.406 (10.30)	0.459 (11.65)	0.250 (6.35)
1/4"	0.404 (10.25)	0.445 (11.30)	0.500 (12.65)	0.289 (7.35)
5/16"	0.482 (12.25)	0.524 (13.30)	0.577 (14.65)	0.356 (9.05)
3/8"	0.636 (16.15)	0.681 (17.30)	0.748 (19.00)	0.457 (11.62)
1/2"	0.726 (18.45)	0.768 (19.50)	0.835 (21.20)	0.572 (14.52)

Port Form Dimensions

G Tube O.D.	A		E Depth ±0.004	F Depth ±0.004	G	N Depth +0.006 -0.00			M Rec Min Wall Thickness		M Rec Min Wall Thickness	
	+0.004 -0.0	C*** ±0.002				S Max	T Max	P*** +0.004 -0.002	P*** +0.002 -0			
1/8"	0.130 (3.30)	0.246 (6.25)	0.453 (11.50)	0.335 (8.50)	0.091 (2.30)	0.262 (6.65)	0.028 (0.70)	0.012 (0.30)	0.059 (1.50)	0.303 (7.70)	0.039 (1.00)	0.307 (7.80)
5/32" (4)	0.161 (4.08)	0.274 (6.95)	0.476 (12.10)	0.343 (8.70)	0.110 (2.80)	0.236 (6.00)	0.028 (0.70)	0.012 (0.30)	0.059 (1.50)	0.323 (8.20)	0.039 (1.00)	0.327 (8.30)
3/16"	0.191 (4.85)	0.321 (8.15)	0.508 (12.90)	0.382 (9.70)	0.134 (3.40)	0.268 (6.80)	0.028 (0.70)	0.020 (0.50)	0.059 (1.50)	0.362 (9.20)	0.039 (1.00)	0.366 (9.30)
1/4"	0.254 (6.45)	0.362 (9.20)	0.524 (13.30)	0.402 (10.20)	0.173 (4.40)	0.287 (7.30)	0.028 (0.70)	0.020 (0.50)	0.059 (1.50)	0.402 (10.20)	0.039 (1.00)	0.406 (10.30)
5/16" (8)	0.319 (8.10)	0.445 (11.30)	0.563 (14.30)	0.406 (10.30)	0.236 (6.00)	0.287 (7.30)	0.028 (0.70)	0.020 (0.50)	0.059 (1.50)	0.474 (12.05)	0.039 (1.00)	0.484 (12.30)
3/8"	0.379 (9.62)	0.549 (13.95)	0.740 (18.80)	0.579 (14.70)	0.299 (7.60)	0.378 (9.60)	0.028 (0.70)	0.020 (0.50)	0.079 (2.00)	0.628 (15.15)	0.059 (1.50)	0.642 (16.30)
1/2"	0.506 (12.85)	0.670 (17.02)	0.878 (22.30)	0.681 (17.30)	0.380 (9.65)	0.484 (12.30)	0.028 (0.70)	0.020 (0.50)	0.079 (2.00)	0.711 (18.05)	0.059 (1.50)	0.728 (18.50)

*A

**B

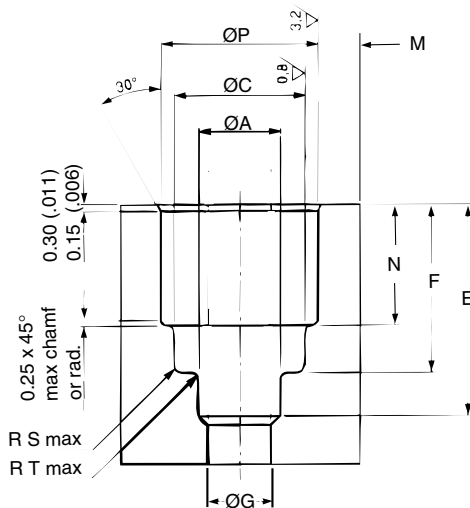

*A The dimensions given are suitable for Nylon 6, Nylon 66 and acetal components. For use in other types of plastic consult the factory.

**B Instructions refer to the use of cartridges in Brass, Aluminum or Zinc components. For use in other materials consult the factory.

*** Diameter limits for "C" and "P" include ovality. Diameters to be concentric within 0.005".



Pneufit Inch Cartridges for Industrial Applications

Dimensions in Inches (mm)

NOTE: MM equivalents are for reference only.

Materials of Construction:

- Collet: Nickel plated Brass
- Cartridge body (insert): Brass
- O-ring: Nitrile (silicone free)

Specifications and Options

Same as Standard Pneufit line, however, cartridges are packaged 100 "kits" per box, with bodies, collets and O-rings packaged separately.

Assembly instructions for installing cartridges into plastic components.

1. Ensure that all parts are clean.
2. Insert the correct end of the cartridge body into the port form (see illustration). Then, using a flat faced tool, press in the cartridge body until it is flush with the surface of the body. Minimum loads should be used to avoid damage to the end faces of the cartridge body.
3. Lubricate the O-ring with appropriate medium grade mineral grease (BP Energol LS2). Locate as shown in port.
4. Insert the collet into the body using minimal force.

Installed Cartridge Fitting Dimensions

Tube O.D.	Part Number	A	B	C	D	E	F
1/8"	12 008 0100	0.26 (6.5)	0.08 (2.0)	0.26 (6.7)	0.33 (8.4)	0.45 (11.4)	0.30 (7.6)
5/32"	12 008 0200	0.30 (7.5)	0.08 (2.0)	0.24 (6.0)	0.34 (8.6)	0.47 (12.0)	0.32 (8.1)
3/16"	12 008 0300	0.39 (10.0)	0.09 (2.2)	0.27 (6.8)	0.38 (9.6)	0.50 (12.8)	0.36 (9.1)
1/4"	12 008 0400	0.43 (11.0)	0.09 (2.2)	0.29 (7.3)	0.40 (10.1)	0.52 (13.2)	0.40 (10.1)
5/16"	12 008 0500	0.51 (13.0)	0.09 (2.2)	0.29 (7.3)	0.40 (10.1)	0.56 (14.2)	0.48 (12.1)
3/8"	12 008 0600	0.57 (14.5)	0.09 (2.2)	0.38 (9.6)	0.57 (14.6)	0.74 (18.7)	0.63 (16.1)
1/2"	12 008 0700	0.71 (18.0)	0.09 (2.2)	0.48 (12.3)	0.68 (17.2)	0.87 (22.2)	0.72 (18.3)

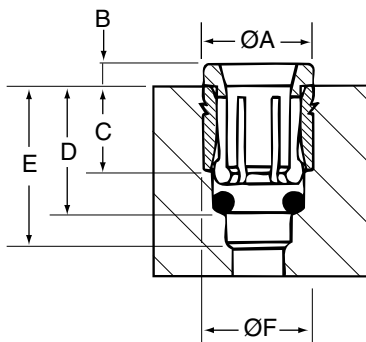
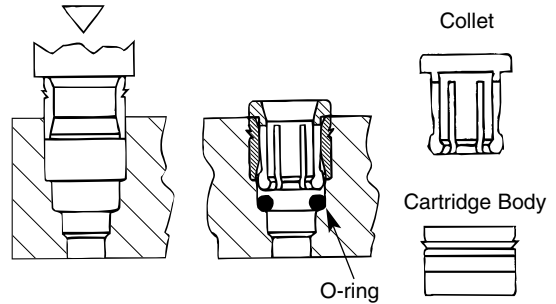



NOTE: Inch equivalents are for reference only.

Assembly instructions for installing cartridges into metal components.

1. Ensure that all parts are clean.
2. Insert the correct end of the cartridge body into the port form (see illustration). Then, using an installation tool as shown in Fig.1, press the cartridge body in until it is flush with the surface while staking it into place (Fig. 3). Minimum loads should be used to avoid damage to the end faces of the cartridge body.
3. Lubricate the O-ring with appropriate medium grade mineral grease (BP Energol LS2). Locate as shown in port.
4. Insert the collet into the body using minimal force.

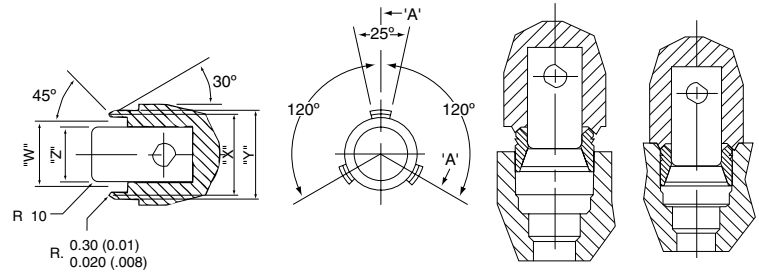

Fig. 1

Fig. 2

Fig. 3

Tube Size	W		Y	
	+0.002 -0.0	X	+0.002 -0.0	Z
4 mm	8.25 (0.324)	9.30 (0.366)	10.65 (0.420)	5.15 (0.203)
5 mm	9.25 (0.364)	10.30 (0.406)	11.65 (0.459)	6.35 (0.250)
6 mm	10.25 (0.404)	11.30 (0.445)	12.65 (0.500)	7.35 (0.289)
8 mm	12.25 (0.482)	13.30 (0.524)	14.65 (0.577)	9.050 (.356)
10 mm	16.15 (0.636)	17.30 (0.681)	19.00 (0.748)	11.62 (0.457)
12 mm	18.45 (0.726)	19.50 (0.768)	21.20 (0.835)	14.52 (0.572)

Port Form Dimensions

G Tube O.D.	A +0.10 -0.0	C ±0.05	E Depth ±0.10	F Depth ±0.10	G	N Depth +0.15 -0.00	S Max	T Max	For Plastic Components		For Metal Components	
									M Rec Min Wall Thickness	P +0.10 -0	M Rec Min Wall Thickness	P +0.05 -0
4	4.08 (.16)	6.95 (.27)	12.10 (.48)	8.70 (.34)	2.80 (.11)	6.00 (.24)	0.7 (.03)	0.30 (.01)	1.5 (.06)	8.20 (.32)	1.0 (.04)	8.30 (.33)
5	5.08 (.20)	8.15 (.32)	12.90 (.51)	9.70 (.38)	3.40 (.13)	6.80 (.27)	0.7 (.03)	0.50 (.02)	1.5 (.06)	9.20 (.36)	1.0 (.04)	9.30 (.37)
6	6.08 (.24)	9.20 (.36)	13.30 (.52)	10.20 (.40)	4.40 (.17)	7.30 (.29)	0.7 (.03)	0.50 (.02)	1.5 (.06)	10.20 (.40)	1.0 (.04)	10.30 (.41)
8	8.10 (.32)	11.30 (.44)	14.30 (.56)	10.30 (.41)	6.00 (.24)	7.30 (.29)	0.7 (.03)	0.50 (.02)	1.5 (.06)	12.05 (.48)	1.0 (.04)	12.30 (.48)
10	10.10 (.40)	13.95 (.55)	18.80 (.74)	14.70 (.58)	7.60 (.30)	9.60 (.38)	0.7 (.03)	0.50 (.02)	2.0 (.08)	15.15 (.63)	1.5 (.06)	16.30 (.64)
12	12.20 (.48)	17.02 (.67)	22.30 (.88)	17.30 (.68)	9.65 (.38)	12.30 (.48)	0.7 (.03)	0.50 (.02)	2.0 (.08)	18.05 (.72)	1.5 (.06)	18.50 (.73)

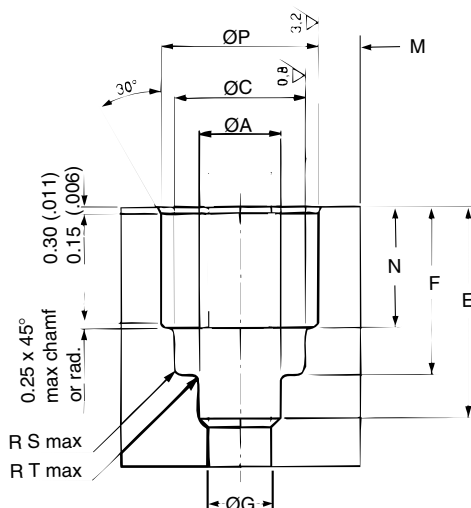

A*

B**

*A The dimensions given are suitable for Nylon 6, Nylon 66 and acetal components. For use in other types of plastic consult the factory.

**B Instructions refer to the use of cartridges in Brass, Aluminum or Zinc components. For use in other materials consult the factory.

***C Diameter limits for "C" and "P" include ovality. Diameters to be concentric within 0.005".



Pneufit Metric Cartridges for Industrial Applications

Dimensions in MM (inches)

NOTE: Inch equivalents are for reference only.

Assembly instructions for installing cartridges into plastic components.

1. Ensure that all parts are clean.
2. Insert the correct end of the cartridge body into the port form (see illustration). Then, using a flat faced tool, press in the cartridge body until it is flush with the surface of the body. Minimum loads should be used to avoid damage to the end faces of the cartridge body.
3. Lubricate the O-ring with appropriate medium grade mineral grease (BP Energol LS2). Locate as shown in port.
4. Insert the collet into the body using minimal force.

Materials of Construction:

Collet: Nickel plated Brass

Cartridge body (insert): Brass

O-ring: Nitrile (silicone free)

Specifications and Options

Same as Standard Pneufit line, however, cartridges are packaged 100 "kits" per box, with bodies, collets and O-rings packaged separately.

Installed Cartridge Fitting Dimensions

Tube O.D.	Part Number	A	B	C	D	E	F
4	10 008 0400	7.5 (.30)	2.0 (.08)	6.0 (.24)	8.6 (.34)	12.0 (.47)	8.1 (.32)
5	10 008 0500	10.0 (.39)	2.2 (0.9)	6.8 (.27)	9.6 (.38)	12.8 (.50)	9.1 (.36)
6	10 008 0600	11.0 (.43)	2.2 (0.9)	7.3 (.29)	10.1 (.40)	13.2 (.52)	10.1 (.40)
8	10 008 0800	13.0 (.51)	2.2 (0.9)	7.3 (.29)	10.1 (.40)	14.2 (.56)	12.1 (.48)
10	10 008 1000	14.5 (.57)	2.2 (0.9)	9.6 (.38)	14.6 (.57)	18.7 (.74)	16.1 (.63)
12	10 008 1200	18.0 (.71)	2.2 (0.9)	12.3 (.48)	17.2 (.68)	22.2 (.87)	18.3 (.72)

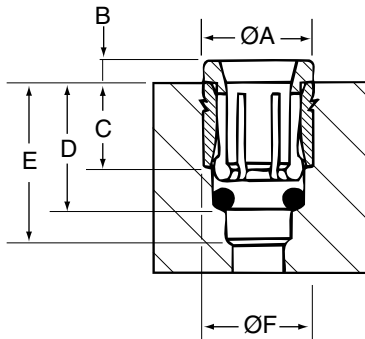
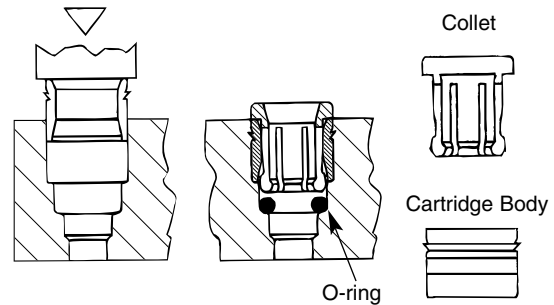

Tubing and Accessories



Inch Industrial TubingFIT-7-2
Metric Industrial TubingFIT-7-3
Inch D.O.T. TubingFIT-7-3
Accessories and Replacement PartsFIT-7-4



Inch Industrial Tubing

- Recommended for use with Pneufit Push-In Fittings
- Manufactured from Nylon 11
- UL-94HB flame retardant rating
- Heat and light stabilized
- Shipped in 100 ft. coils (30m) packed in polyethylene bags

Specifications

Fluids: Compressed air, nitrogen and inert gases
 Material: Nylon 11
 Temperature Rating: -60°F to 200°F (-5°C to 93°C)*
 Vacuum Rating: To 28° Hg (711 mm Hg)
 Diameter Tolerances: + 0.002"; -0.004"
 Hardness: 78 Rockwell R

Technical Information High Flow Inch Tubing

Tubing				Maximum Working Pressure -40°F to 70°F (-40°C to 20°C)		Minimum Bend Radius		Part Number and Color					
OD (inch)	ID (inch)	OD (mm)	ID (mm)	psig	bar	inch	mm	Natural	Black	Blue	Green	Red	Yellow
1/8	0.093			225	15.5	0.38	10	PB 0051 100	PB 0751 100	PB 0551 100	PB 0251 100	PB 0151 100	PB 0351 100
5/32	0.106	4	2.3	275	19.0	0.50	13	PB 0052 100	PB 0752 100	PB 0552 100	PB 0252 100	PB 0152 100	PB 0352 100
3/16	0.138			225	15.5	0.63	16	PB 0053 100	PB 0753 100	PB 0553 100	PB 0253 100	PB 0153 100	PB 0353 100
1/4	0.180			250	17.2	0.88	22	PB 0054 100	PB 0754 100	PB 0554 100	PB 0254 100	PB 0154 100	PB 0354 100
5/16	0.232	8	5.5	220	15.2	1.25	32	PB 0055 100	PB 0755 100	PB 0555 100	PB 0255 100	PB 0155 100	PB 0355 100
3/8	0.275			220	15.2	1.50	38	PB 0056 100	PB 0756 100	PB 0556 100	PB 0256 100	PB 0156 100	PB 0356 100
1/2	0.375			200	13.8	2.00	51	PB 0057 100	PB 0757 100	PB 0557 100	PB 0257 100	PB 0157 100	PB 0357 100

Notes

The working pressure for Nylon 11 tubing is calculated using a 4 to 1 safety factor.
 * To determine working pressures at other temperatures, see chart. Tubing is supplied in 100 ft. (30.5m) coils, packaged in poly bags. For other colors, lengths or packaging, please consult factory.

Working Pressure at Elevated Temperature

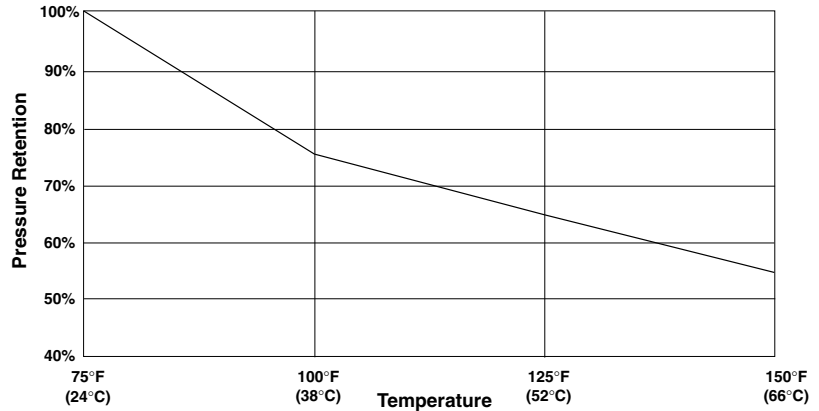

- Recommended for use with Pneufit Push-In Fittings
- Manufactured from Polyurethane
- Shipped 100' coils packed in Polyethylene bags

Specifications

Fluids: Compressed air
 Material: 95 Durometer Polyurethane
 Temperature Rating: -40°F to 165°F (-40°C to 73°C)
 Vacuum Rating: To 28° Hg (711 mm Hg)
 Diameter Tolerances: ± 0.005"



Technical Information Tube Types

Tubing		Maximum Working Pressure at 75°F		Minimum Bend Radius	Part Number and Color				
OD (mm)	ID (mm)	psig	bar		Natural	Black	Trans Blue	Trans Green	Trans Red
1/8"	.066	233	16.1	1/4"	PW 0051 100	PW 0751 100	PW 0551 100	PW 0251 100	PW 0151 100
5/32"	.094	176	12.1	3/8"	PW 0052 100	PW 0752 100	PW 0552 100	PW 0252 100	PW 0152 100
1/4"	.160	148	10.2	1/2"	PW 0054 100	PW 0754 100	PW 0554 100	PW 0254 100	PW 0154 100
5/16"	.197	155	10.7	3/4"	PW 0055 100	PW 0755 100	PW 0555 100	PW 0255 100	PW 0155 100
3/8"	.245	147	10.1	7/8"	PW 0056 100	PW 0756 100	PW 0556 100	PW 0256 100	PW 0156 100



- Recommended for use with Pneufit Push-In Fittings.
- Manufactured from Nylon 12
- Resistant to many chemicals
- Excellent pressure rating
- Black tubing provides reduced ultraviolet degradation
- Conforms to BS5409-1:1976 and DIN 73378
- Shipped in 25 meter (82 ft.) coils packed in polyethylene bags.

Specifications

Fluids: Compressed air, nitrogen and inert gases
 Material: Nylon 12
 Maximum continuous working temperature:
 80°C (175°F)

Technical Information for Metric Tubing

Tubing		Maximum Working Pressure -40°C to 20°C (-40°F to 70°F)		Minimum Bend Radius		Part Number and Color				
OD (mm)	ID (mm)	bar	psig	mm	inch	Natural	Black	Blue	Green	Red
4	2.5	28.0	406	25	0.98	PA 0004 025	PA 0704 025	PA 0504 025	PA 0204 025	PA 0104 025
5	3.0	31.0	450	25	0.98	PA 0005 025	PA 0705 025	PA 0505 025	PA 0205 025	PA 0105 025
6	4.0	25.0	362	30	1.18	PA 0006 025	PA 0706 025	PA 0506 025	PA 0206 025	PA 0106 025
8	6.0	19.0	275	50	1.97	PA 0008 025	PA 0708 025	PA 0508 025	PA 0208 025	PA 0108 025
10	7.5	24.0	348	60	2.36	PA 0010 025	PA 0710 025	PA 0510 025	PA 0210 025	PA 0110 025
12	9.0	18.0	261	75	2.95	PA 0012 025	PA 0712 025	PA 0512 025	PA 0212 025	PA 0112 025
14	11.0	15.0	218	80	3.15	PA 0014 025	PA 0714 025	PA 0514 025	PA 0214 025	PA 0114 025

For other colors, lengths or packaging, please consult factory.

C-Clips

For color coding and tamper-resistant feature



	1/8" – 5/32" 3mm – 4mm	1/4" 6mm	5/16" 8mm	3/8" 10mm
Red	48A35501	48B35501	48C35501	48D35501
Yellow	48A35502	48B35502	48C35502	48D35502
Orange	48A35503	48B35503	48C35503	48D35503
Green	48A35504	48B35504	48C35504	48D35504
Black	48A35505	48B35505	48C35505	48D35505
Brown	48A35506	48B35506	48C35506	48D35506
Violet	48A35507	48B35507	48C35507	48D35507
Blue	48A35508	48B35508	48C35508	48D35508
White	48A35509	48B35509	48C35509	48D35509
Silver	48A35510	48B35510	48C35510	48D35510

Boxed in quantities of 30

- Recommended for use with FleetFit® DOT Push-In Fittings
- Manufactured from Nylon 12
- Saves up to 75% in weight over metal tubing.
- Resistant to most oils, grease, gasolines, diesel fuel, road salts and moisture.
- Excellent pressure rating.
- Conforms to SAE J844d.
- Shipped in cardboard cartons.

Specifications

Fluids: Compressed air
 Material: 1/4" – single wall, non-reinforced (Type 3A)
 3/8" to 5/8" – Multi-layer, complete with a seamless Nylon core tube, synthetic fiber reinforcement and an abrasion-resistant nylon covering (Type 3B)
 Temperature Range: -40° to 200°F (-40° to 93°C)

Technical Information for FleetFit® DOT Tubing

Tubing			Minimum Burst Pressure at 70°F(20°C)		Minimum Bend Radius		Part Number and Color					
OD (inch)	ID (inch)	Coil Length (ft.)	psig	bar	inch	mm	Black	Red	Orange	Yellow	Green	Blue
1/4"	0.170	1000	1200	82.8	1.0	25	4246 04106	4246 04126	4246 04136	4246 04146	4246 04156	4246 04166
3/8"	0.251		1400	96.6	1.5	38	3250 06104	3250 06124	3250 06134	3250 06144	3250 06154	3250 06164
1/2"	0.378		950	65.5	2.0	51	3250 08104	3250 08124	3250 08134	3250 08144	3250 08154	3250 08166
5/8"	0.441		900	62.1	2.5	63	3250 10103	3250 10123	3250 10133	3250 10145	3250 10155	3250 10163



Accessories and Replacement Parts

Tube Cutter

- Makes clean, square cuts in Nylon tubing that are necessary for leak free connections.
- Small size (3" long, 1" wide, 1" high) makes it easy to use and
- Spring actuation keeps it closed when not in use.
- Order part number **M/3314**.
- Replacement blades (5 pack) **M/32009**

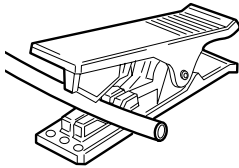

Tube Mount - 2 Channel

- Save installation time - tube mounts provide quick, secure mounting and exact spacing between tubes.
- Tubing snaps into channels for clean, organized circuits.
- Tube mounts are drilled for machine screw mounting.

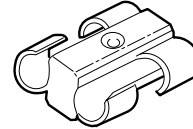

Tube Markers

- PVC tube markers eliminate confusing fluid power connections by providing easy to read identification.
- Permanent, hot stamped black characters on white background are not affected by grease, oil, or lubricating fluids.
- Markers snap on without tools before or after tube terminations made. Can be removed without disconnecting tubing.
- Non-adhesive interior of marker will not pinch, kink, or mar tubing.

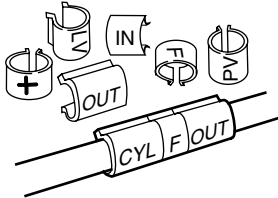

Part Number	Tube Size	Mounting Screw Size	Color
94 910 004	5/32" & 4 mm	#4	Black
94 910 006	1/4" & 6 mm	#4	Black
94 910 008	5/16" & 8 mm	#6	Black
94 910 010	3/8"	#6	Black
94 910 012	1/2"	#6	Black
94 910 015	5/8"	#10	Black

Code	Tube Marker Kits			
	Tube Size (O.D.)			
	1/8"	5/32" & 4 mm	1/4" & 6 mm	3/8"
Alphanumeric Kit*	94 911 025	94 911 058	94 911 091	94 911 124
Descriptive Kit**	94 911 033	94 911 066	94 911 099	94 911 132

* Contains 50 each of all numbers (0-9) and letters (A-H, J, P, R, X, Y, and Z)
 ** Contains 50 each of CYL, PV, LV, IN, OUT, + and -.

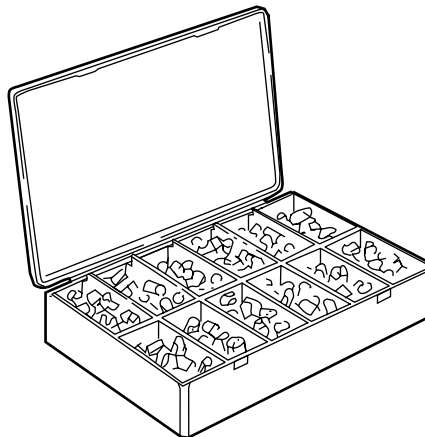



Tube Mount - 10 Channel

- Full 10 channel section (4" long, 5/8" wide and 3/8" high) is easily cut for 1 to 10 channels.
- Each channel is countersunk for No. 4 machine screws.
- Tubing snaps into channels for clean, organized circuits.
- Pressure sensitive Urethane foam adhesive backing for quick mounting (except 3/8" model).
- Slotted design allows mounting on curved or angular surfaces. Color of mounts match machine or tubing.

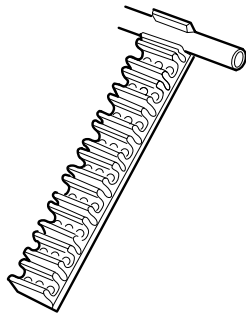

Part Number	Tube Size	Mounting Screw Size	Color
94 902 002	5/32" & 4 mm	#4	Black
94 902 003	3/16"	#4	Black
94 901 004	1/4" & 6 mm	#4	White
94 902 004	1/4" & 6 mm	#4	Black
94 903 004	1/4" & 6 mm	#4	Blue
94 904 004	1/4" & 6 mm	#4	Green
94 905 004	1/4" & 6 mm	#4	Red
94 906 004	1/4" & 6 mm	#4	Yellow
94 908 004	1/4" & 6 mm	#4	Grey
94 902 006	3/8" & 10 mm	-	Black

Spiral Flex Wrap

- Natural color Polyethylene spiral flex wrap twists easily over bundles of various sized tubing or insulated electric wire.
- Nominal 1/2" O.D. accommodates bundles from 3/8" to 4" in diameter. Can be wrapped for greater flexibility or butted for rigidity.
- Tubing or wire can be led out at any point.
- Provided in 50' (15 meter) coils.
- Order part number **94 960 001**.

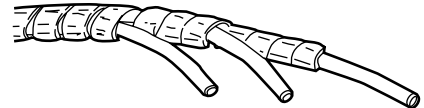

Release Tool

Used to disconnect tubing from all Norgren fittings. Helps in situations where fitting is difficult to reach.

Part Number: **54 0001 00**

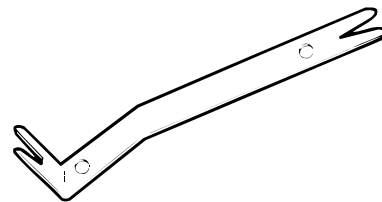

Replacement Parts

- 48 030 005** Replacement thermoplastic sealing washer for use with 10-32 and M5 threads. Sold individually.
- 48 021 605V** Replacement viton bonded sealing washer for use with 10-32 and M5 threads. Sold in package of 10.

Mufflers

Quietaire® Series

Compressed Air Mufflers



Features and BenefitsFIT-8-2
Muffler Shape CodesFIT-8-3
Shell Type Quietaire® MufflersFIT-8-4
Nadir Air Exhaust SilencerFIT-8-5
Sintered Type Quietaire® MufflersFIT-8-6
Porous Plastic Type Quietaire MufflersFIT-8-7
Quietaire® Coalescing MufflersFIT-8-8
High Performance Coalescing Quietaire® MufflersFIT-8-9
Quietaire® Speed Control MufflersFIT-8-10
Quietaire® Breather VentsFIT-8-13
Quietaire® Small Part EjectorsFIT-8-14

- Mufflers prevent metal chips, abrasive grits, dust and other contaminants from entering open exhaust ports and causing premature valve failure.
- Coalescing Mufflers help prevent oil mist and solid particles from contaminating factory air.
- Speed Control Mufflers allow the adjustment of exhaust flow to accurately control cylinder speed.
- Parts Ejectors use less air than open lines with only minor reduction of thrust.
- Breather vents prevent damage caused when dirt, chips and other foreign particles enter vacuum relief ports or breather tubes.



OSHA Permissible Noise Exposures*

Compressed air exhausts generate high intensity sound energy, much of it in the same frequency range as normal conversation. Prolonged exposure to noise causes hearing impairment without noticeable pain or discomfort. See Table below for permissible noise exposures and graphs on the following pages for the sound suppression characteristics of Quietaire products.

Daily Duration (Hours)	Sound Level (dBa)
8	90
6	92
4	95
3	97
2	100
1-1/2	102
1	105
1/2	110
1/4	115

*OSHA Safety and Health Standards (29 CFR 1910.95)

Increase Productivity

Continual noise causes worker fatigue, resulting in reduced productivity and a reduction in profits. Noise abatement helps prevent noise fatigue, one of the main causes of industrial inefficiency and accidents.

Cleaner Work Environment

Open exhaust ports on compressed air devices can release oil vapors, oil aerosols, and particulates into the atmosphere. Quietaire coalescing mufflers remove these contaminants from the exhaust air and also reduce noise to permissible levels.

Prolong Service Life

Open exhaust ports invite the entry of contaminants - metal chips, abrasive grits, sweepings (floor mounted units) and other debris. Quietaire mufflers prevent the entry of such contaminants, prolonging the service life of your air valves, air motors and similar equipment.

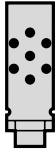

Shell Type Quietaire Heavy Duty Mufflers
(MA and MB Series) p. FIT-8-4.

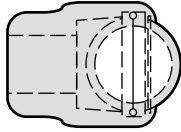

Nadir Air Exhaust Silencer
(MF and MFT Series) p. FIT-8-5.

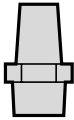

Sintered Type Quietaire Mufflers
(MS and T40 Series) p. FIT-8-6.



Porous Plastic Type Quietaire Mufflers
(C/S, M/S, and MU Series) p. FIT-8-7.

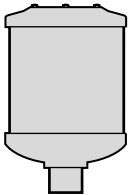

Coalescing Quietaire Mufflers
(MC Series) p. FIT-8-8.



High Performance Quietaire Coalescing Muffler
(MQ Series) p. FIT-8-9.

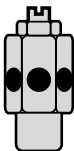

Quietaire Speed Control Mufflers
(MM and T20 Series) p. FIT-8-10.



Quietaire Breather Vents
(MV and M/1510 Series) p. FIT-8-13.



Quietaire Small Parts Ejectors
(ME Series) p. FIT-8-14.



Shell Type Quietaire Mufflers

Dimensions in Inches (mm)

- Superior sound attenuation
- High flow capacity
- Low back pressure
- Corrosion resistant construction
- Brass mesh screen and aluminum construction provide improved flow, longer life, and a cleanable element.

Male Thread

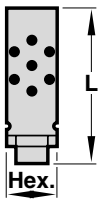

Port Size NPT	NPT (std)	ISO R (opt)	Flow Factor Cv + -10%	Dimensions	
				Hex.	L
1/8	MB001A	MB001B	2	13/16 (20.6)	2.00 (50.9)
1/4	MB002A	MB002B	2.7	13/16 (20.6)	2.17 (55.2)
3/8	MBP03A	MBP03B	3.2	13/16 (20.6)	2.17 (55.2)
3/8	MB003A	MB003B	4.9	1-1/4 (31.8)	3.47 (88.1)
1/2	MB004A	MB004B	5.9	1-1/4 (31.8)	3.62 (91.9)
3/4	MBP06A	MBP06B	5.9	1-1/4 (31.8)	3.64 (92.4)
3/4	MB006A	MB006B	13.5	2 (50.8)	5.28 (134.0)
1	MB008A	MB008B	16.7	2 (50.8)	5.43 (138.0)
1-1/4	MBP10A	MBP10B	17.4	2 (50.8)	5.51 (140.0)
1-1/2	-	-	-	-	-
2	-	-	-	-	-
2-1/2	-	-	-	-	-

Female Thread

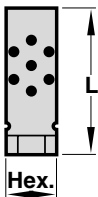

Port Size NPT	NPT (std)	ISO R (opt)	Flow Factor Cv + -10%	Dimensions	
				Hex.	L
1/8	MA001A	MA001B	0.8	13/16 (20.6)	1.67 (42.4)
1/4	MA002A	MA002B	2.4	13/16 (20.6)	1.78 (45.2)
3/8	MA003A	MA003B	5.7	1-1/4 (31.8)	3.08 (78.3)
1/2	MA004A	MA004B	6.9	1-1/4 (31.8)	3.29 (83.5)
3/4	MA006A	MA006B	18.0	2 (50.8)	4.65 (118.0)
1	MA008A	MA008B	20.0	2 (50.8)	4.65 (118.0)
1-1/4	MA010A	MA010C	42.0	2-1/2 (63.5)	5.67 (144.0)
1-1/2	MA012A	MA012C	39.0	2-1/2 (63.5)	5.67 (144.0)
2	MA016A	MA016C	59.0	3 (76.2)	6.61 (168.0)
2-1/2	MA020A	MA020C	-	4 (102)	7.13 (181)

Technical Data

Maximum Pressure: 300 psig (20.7 bar)

Maximum temperature: 176°F (80°C)

Materials

Element: Brass wire

Base: Aluminum

Shell: Aluminum

Graphic Symbol





- Meets all OSHA standards
- Machined from high tensile aluminum with no plastics or castings
- Will pass particle contaminants to 100 microns
- Easily cleaned for longer service life
- Can withstand temperatures of 1000 degrees F

Technical Data

Maximum Pressure: 150 psi (10 bar)
 Maximum temperature: 1000°F (538°C)

Materials

Aluminum and Sintered Bronze

Graphic Symbol

Model	A Barrell	B Overall	C Dia	D Thread	E Flats
MF-14	1-15/32	1-15/16	1-1/4	1/4 NPT	1-5/32
MFT-38	1-15/32	1-15/16	1-1/4	3/8 NPT	1-5/32
MF-38	1-3/4	2-5/16	1-1/2	3/8 NPT	1-1/4
MFT-12	1-3/4	2-5/16	1-1/2	1/2 NPT	1-1/4
MF-12	1-7/8	2-5/8	1-3/4	1/2 NPT	1-1/2
MFT-34	1-7/8	2-5/8	1-3/4	3/4 NPT	1-1/2
MF-34	3-5/16	4-7/8	2-3/8	3/4 NPT	
MFT-1	3-5/16	4-7/8	2-3/8	1 NPT	
MF-100	4-3/8	6-1/2	3	1 NPT	
MFT-114	4-3/8	6-1/2	3	1-1/4 NPT	
MF-114	5-9/16	8-11/32	4	1-1/4 NPT	
MFT-112	5-9/16	8-11/32	4	1-1/2 NPT	
MF-112	6-1/2	9-7/8	4-1/2	1-1/2 NPT	
MFT-200	6-1/2	9-7/8	4-1/2	2 NPT	

Dimensional Data

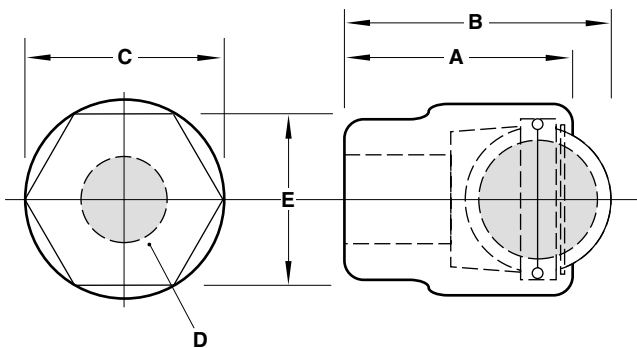

Dimensional Data

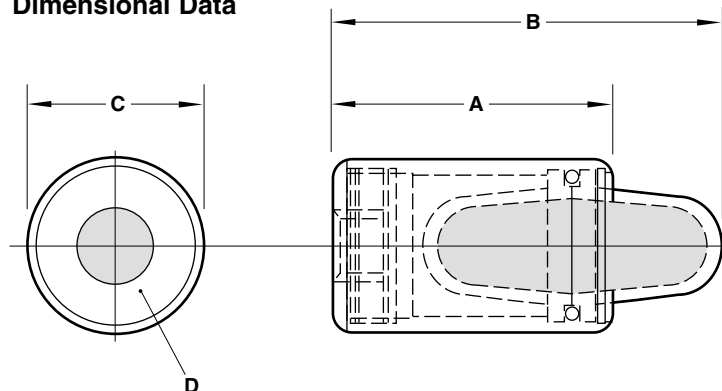



Sintered Type Quietaire Mufflers

Dimensions in Inches (mm)

- Reduces noise levels of pneumatic equipment
- Cleanable 40-micron diffuser elements
- Compact design
- Corrosion resistant construction
- Prevents dirt ingress

Male Thread

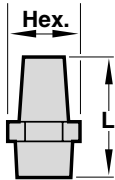

Port Size NPT	Part Number	Flow Factor Cv	Hex.	Dimensions L
10-32	MS000A	—	5/16	0.70 (18)
1/8	MS001A	0.7	7/16	1.13 (29)
1/4	MS002A	1.4	9/16	1.38 (35)
3/8	MS003A	1.9	11/16	1.50 (38)
1/2	MS004A	3.8	7/8	1.88 (48)
3/4	MS006A	6.5	1-1/16	2.25 (57)
1	MS008A	10.5	1-5/16	2.88 (73)
1-1/4	MS010A	11.8	1-11/16	3.25 (83)
1-1/2	MS012A	18.3	2	3.69 (94)

Port Size ISO G	Part Number	Flow Factor Cv	Hex.	Dimensions L
M5	T40M0500	0.2	7	0.79 (20)
1/8	T40C1800	0.54	13	0.94 (24)
1/4	T40C2800	1.6	17	1.30 (33)
3/8	T40C3800	3.5	22	1.73 (44)
1/2	T40C4800	5.1	27	2.20 (56)
3/4	T40C6800	9.0	32	3.15 (80)
1	T40C8800	11.6	41	3.23 (82)

Technical Data

Maximum Pressure: NPT - 300 psig (20.7 bar)
 ISO - 150 psig (10 bar)
 Maximum temperature: NPT - 300°F (149°C)
 ISO - 175°F (80°C)

Materials

Element: Sintered bronze
 Base: Nickel plated steel (NPT), Brass (ISO)

Graphic Symbol



Port Size ISO R	Part Number	Flow Factor Cv	Hex.	Dimensions L
1/8	T40B1800	0.54	13	1.08 (27.5)
1/4	T40B2800	1.6	17	1.42 (36)
3/8	T40B3800	3.5	22	1.83 (46.5)
1/2	T40B4800	5.1	27	2.36 (60)
3/4	T40B6800	9.0	32	3.35 (85)
1	T40B8800	11.6	41	1.61 (41)

Performance Characteristics

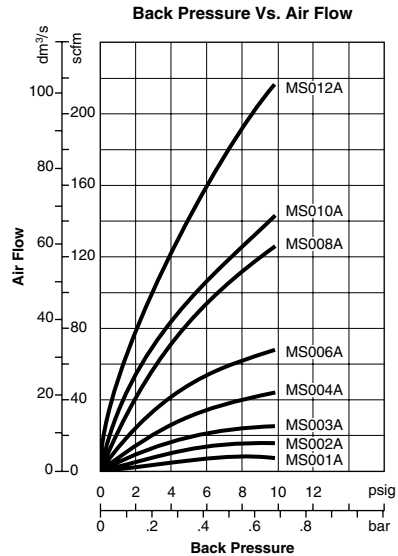
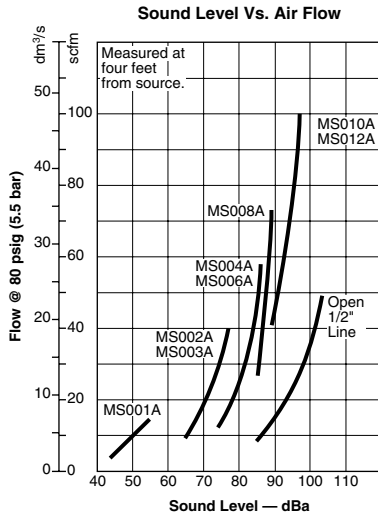

Porous Plastic Type Quietaire Mufflers

Dimensions in Inches (mm)



- Compact and light weight
- Low cost alternative to metal designs
- Threads directly into the exhaust port
- Prevents contamination from dirt

Technical Data

Maximum Pressure: Vacuum to 150 psig (10 bar)
 Maximum Temperature: 125°F (51.7°C) (MU Series)
 Temperature Range: -0° to 175°F (-20° to 80°C) (C/S and M/S series)
 Materials (C/S and M/S series): UHMW Polyethylene porous plastic body and polyethylene base

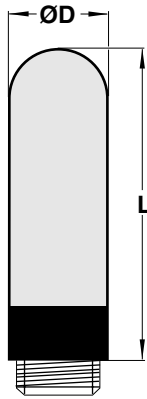

Port Size	Part Number		Dimensions		Weight oz. (g)
	NPT	Metric or ISO G	L (mm)	D (mm)	
M5	-	M/S0*	0.75 (18.9)	0.26 (6.5)	0.01 (.35)
1/8	C/S1	M/S1	1.12 (28.3)	0.50 (12.5)	0.06 (1.3)
1/4	C/S2	M/S2	1.40 (35.5)	0.62 (15.5)	0.10 (2.9)
3/8	C/S3	M/S3	2.20 (56.0)	0.73 (18.5)	0.26 (6.7)
1/2	C/S4	M/S4	2.65 (67.0)	0.91 (23.0)	0.41 (11.5)
3/4	C/S6	M/S6	4.88 (123.5)	1.50 (38.0)	1.41 (40.0)
1	C/S8	M/S8	5.54 (140.5)	2.00 (49.0)	2.12 (60.0)

* Due to the pliable nature of the thermoplastic base material this may be installed in 10-32 UNF ports. (Formerly part number M/1545.)

Port Size	Part Number		Max. Flow Factor Cv**	ΔContinuous Sound Pressure Level (dBA)	
	NPT	ISO G		10 psig (0.7 bar)	90 psig (6 bar)
M5		M/S0	0.31	59	84
1/8	C/S1	M/S1	0.98	67	81
1/4	C/S2	M/S2	1.93	58	81
3/8	C/S3	M/S3	3.75	65	79
1/2	C/S4	M/S4	3.00	59	73
3/4	C/S6	M/S6	7.79	71	89
1	C/S8	M/S8	9.63	70	82

**Cv measured in US gal/min
 Δ SPL at 3.28 ft. (1m) from unit



Quietaire Coalescing Mufflers

Dimensions in Inches (mm)

- Easily replaceable cartridge element
- Removal of oil mist from exhaust air provides cleaner work environment.
- Rugged, corrosion resistant construction

Technical Data

Maximum Pressure: 300 psig (20.7 bar)
 Maximum temperature: 160°F (71°C)

Materials

Element: Fiberglass
 Base: Aluminum
 Shell: Plated steel

Replacement Kit

Element Cartridge: 70039-01

Graphic Symbol

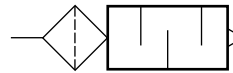

Male Thread

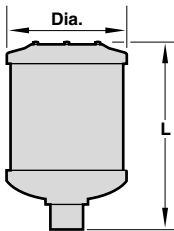

Port Size NPT	Part Number	Flow Factor Cv	Dimensions Dia.	L
1/2	MC004A	5.2	3.88 (99)	6.00 (152)
3/4	MC006A	9.2	3.88 (99)	6.00 (152)
1	MC008A	15.7	3.88 (99)	6.19 (157)

Performance Characteristics

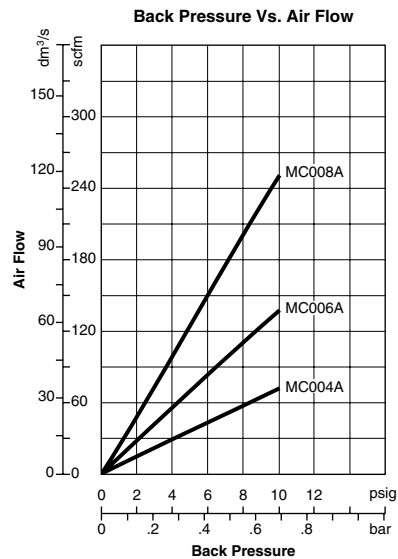
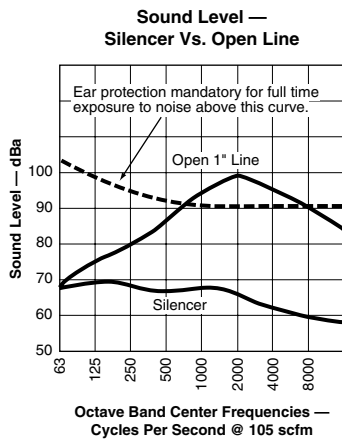

High Performance Coalescing Quietaire Mufflers

Dimensions in Inches (mm)



- Easily replaceable cartridge element
- Corrosion resistant construction
- Snap-on liquid sump with manual drain to collect coalesced oil.
- High-performance cartridge removes up to 99% of the oil mist from the exhaust air.

Technical Data

Maximum Pressure: 150 psig (10.3 bar)
Maximum Temperature: 160°F (71°C)

Materials

Element: Steel, synthetic foam and fiber
Body: Aluminum
Sump: Polypropylene
Elastomer: Nitrile

Replacement Kits

Element:
MQ004A and MQ006A – 3236-01
MQ008A and MQ010A – 3237-01
Sump with Drain:
MQ004A and MQ006A – 70048-50
MQ008A and MQ010A – 70048-51

Graphic Symbol

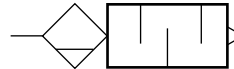

Female Thread

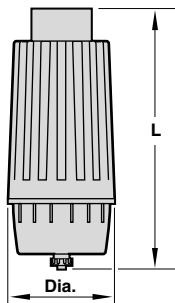

Port Size NPT	Part Number	Flow Factor Cv	Dimensions Dia.	L
1/2	MQ004A	2.5	3.54 (90)	7.09 (180)
3/4	MQ006A	2.5	3.54 (90)	7.09 (180)
1	MQ008A	7.7	4.33 (110)	10.51 (267)
1-1/4	MQ010A	7.7	4.33 (110)	10.51 (267)

Performance Characteristics

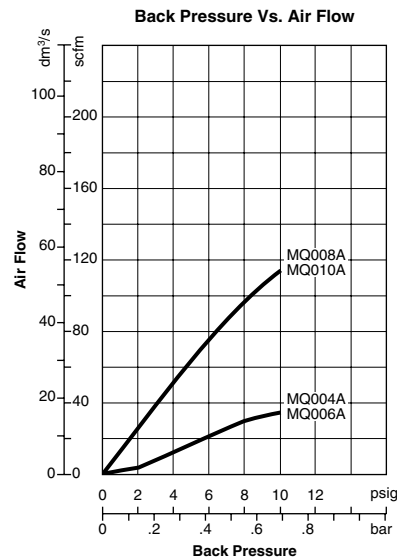
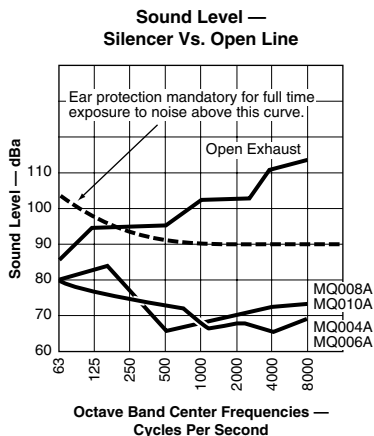



Quietaire Speed Control Mufflers

Dimensions in Inches (mm)

- Cleanable 40-micron sintered bronze diffuser element.
- Corrosion resistant construction.
- Adjustment screw to control rate of exhaust air flow.
- Adjustment screw facilitates a smooth, steady change to flow when turned.

Technical Data

Maximum Pressure: 300 psig (20.7 bar)
 Maximum temperature: 160F (71°C)

Materials

Element: Sintered bronze
 Base: Brass

Graphic Symbols

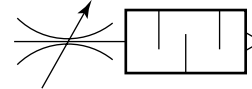

Male Thread

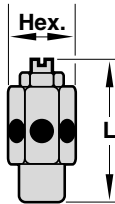

Port Size NPT	Part Number	Dia.	L
1/8	MM001A	1/2	1.53 (39)
1/4	MM002A	9/16	1.91 (49)
3/8	MM003A	11/16	1.91 (49)
1/2	MM004A	7/8	2.34 (59)
3/4	MM006A	1-1/16	2.84 (72)
1	MM008A	1-5/16	3.03 (77)

Performance Characteristics

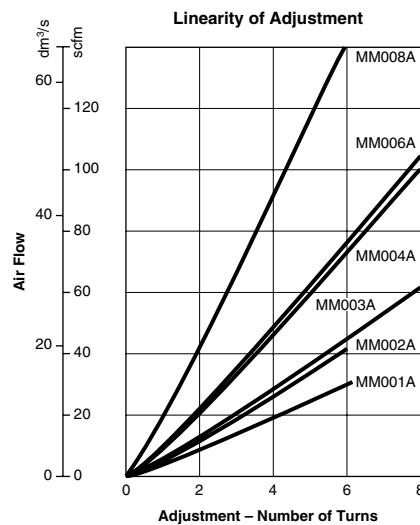
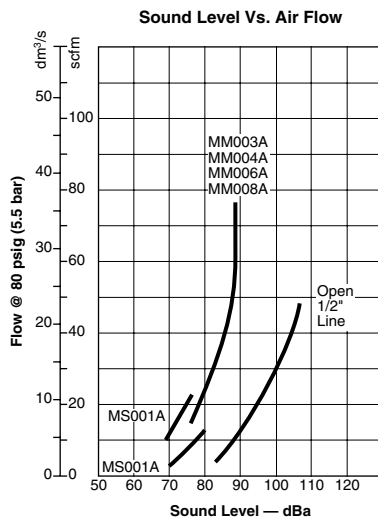

Quietaire Speed Control Mufflers (plastic bodied) T20 Series

M5, 1/8 - 1/2 NPT and ISO G



- Compact, integral speed control and silencer units
- Captive adjustment screw will not blow out when unscrewed
- Reduced dimensions
- Low cost alternative to metal designs

Ordering information

To order quote model number from table overleaf, e.g. T20A4800 for the regulator/silencer 1/2" NPT speed control muffler.

Flow Regulator/Silencer

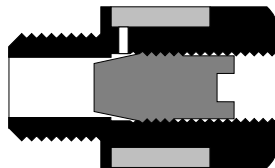

Technical Data

Medium:

Compressed air, filtered, lubricated and non-lubricated, inert gases

Mounting:

Threads directly in the exhaust port. (Thread into port until washer under the element bottoms against the port surface.)

Hex recess adjustment for flow regulation

Port Sizes: Male Thread

NPT	Metric	ISO G
1/8 T20A1800	M5* T20M0500	G1/8 T20C1800
1/4 T20A2800		G1/4 T20C2800
3/8 T20A3800		G3/8 T20C3800
1/2 T20A4800		G1/2 T20C4800

Note: Due to the pliable nature of the thermoplastic base these may be used in conjunction with 10-32 UNF ports.

Operating Pressure:

0 - 145 psi (0 - 10 bar)

Operating Temperature:

-0° to 175°F* (-20° to 80° C)

*Air supply must be dry enough to avoid ice formation at temperatures below 36°F (2°C)

Materials:

Nylon body and washer

(Note: NPT models black, metric and ISO G models red)

Porous polyethylene silencer

Zinc electroplated high tensile steel adjusting screw

M5

Nylon body

Zinc electroplated high tensile steel adjusting screw



Quietaire Speed Control Mufflers

Dimensions in Inches (mm)

General Information

Port Size	Part Number		Max. Flow Factor Cv*	Dimensions							Weight oz. (g)
	NPT	Metric or ISO G		A	B	C	Thread D	E A/F	F A/F	G	
M5	-	T20M0500	0.07	0.63 (16)	0.43 (16)	-	M5	1.5	0.31 (8)	0.36 (9.25)	.04 (1)
1/8	T20A1800	T20C1800	0.4	0.81 (20.5)	0.57 (14.5)	0.20 (5)	1/8	2.5	0.51 (13)	0.59 (15)	.11 (3)
1/4	T20A2800	T20C2800	0.8	1.14 (29)	0.87 (22)	0.27 (7)	1/4	2.5	0.59 (15)	0.71 (18)	.25 (7)
3/8	T20A3800	T20C3800	1.7	1.50 (38)	1.18 (30)	0.41 (10.5)	3/8	2.5	0.79 (20)	0.94 (24)	.67 (19)
1/2	T20A4800	T20C4800	2.4	1.97 (50)	1.57 (40)	0.59 (15)	1/2	2.5	0.98 (25)	1.18 (30)	1.52 (43)

*Cv measured in US gal/min

Speed Control Muffler (1/8 - 1/2 pipe)

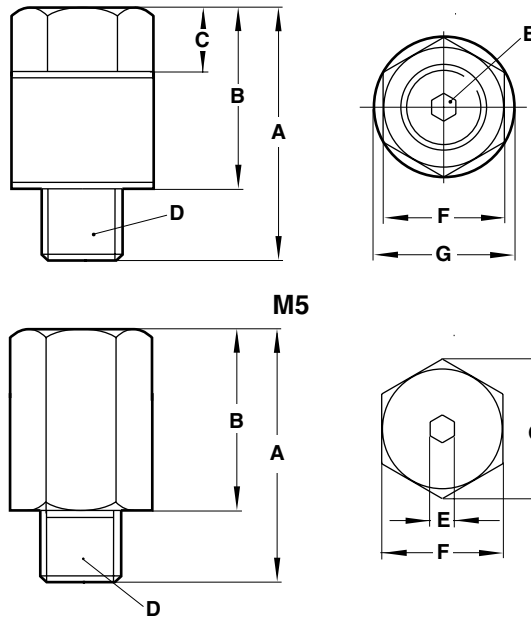

Performance Characteristics Flow vs Turns

(at 90 psig [6 bar] inlet pressure)

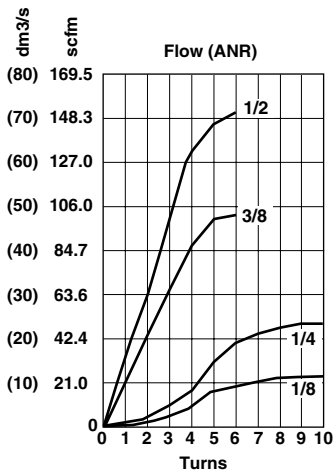

Performance Characteristics Flow vs Turns

(at 90 psig [6 bar] inlet pressure)

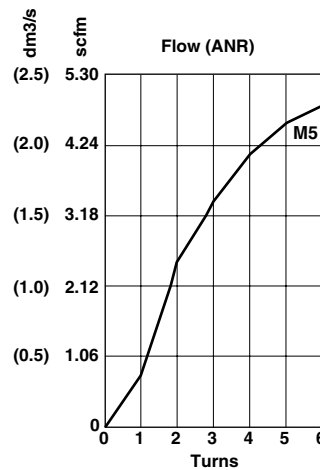



- Corrosion resistant construction
- Prevents contamination from dirt
- Rugged and compact
- Screws directly into the exhaust port
- Sintered bronze element

Technical Data

Maximum Pressure: 150 psig (10.7 bar)
 Maximum temperature: NPT - 300°F (149°C)
 ISO - 175°F (80°C)

Materials

NPT:

Base - Nickel plated steel
 Element - Sintered bronze

ISO G:

Base - Aluminum
 Element - Sintered bronze

Graphic Symbol

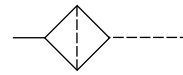

Male Thread

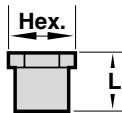

Port Size NPT	Part Number	Flow Factor Cv	Dimensions Hex A/F	Dimensions L
1/8	MV001A	0.1	7/16	0.44 (11)
1/4	MV002A	0.1	9/16	0.63 (16)
3/8	MV003A	0.3	11/16	0.75 (19)
1/2	MV004A	0.5	7/8	0.88 (22)
3/4	MV006A	1.3	1-1/16	1.00 (25)
1	MV008A	1.6	1-5/16	1.31 (33)
1-1/4	MV010A	4.2	1-11/16	1.44 (37)
1-1/2	MV012A	5.2	2	1.50 (38)

Performance Characteristics

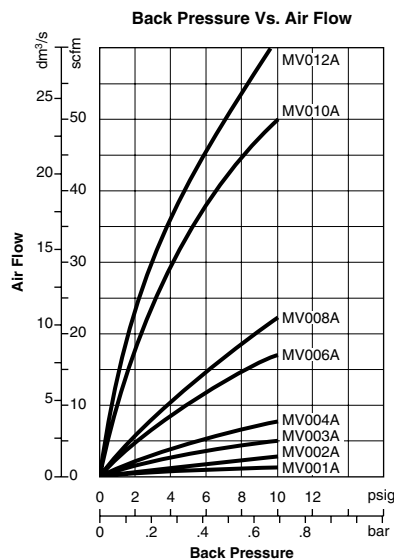

Port Size ISO G	Part Number	Flow Factor Cv	Dimensions Hex A/F	Dimensions L	Weight oz. (g)
1/8	M/1511	0.45	15.0 mm	0.63 (16)	0.2 (6)
1/4	M/1512	1.1	23.5 mm	0.87 (22)	0.6 (18)
1/2	M/1514	1.5	30.5 mm	0.98 (25)	1.0 (30)
3/4	M/1516	3.9	42.5 mm	1.22 (31)	1.6 (50)
1	M/1518	5.5	47 mm	1.38 (35)	2.9 (91)



Quietaire Small Part Ejectors

Dimensions in Inches (mm)

- Reduction in noise and in air consumption (when compared to an open pipe) with only a minor reduction in thrust.
- Corrosion resistant construction.

Technical Data

Maximum Pressure: 150 psig (10.3 bar)
 Maximum temperature: 160°F (71°C)
 Force at 12" (305 mm) from Ejector at 80 psig (5.5 bar) line pressure
 ME002A: 34 ozs. (9.5N)
 Air Consumption at 80 psig (5.5 bar): 63 scfm (29.7 dm³/s)

Materials

Element: Brass cloth
 Base: Aluminum

Graphic Symbol

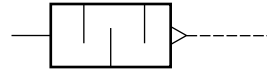

Female Thread

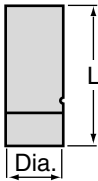

Port Size NPT	Part Number	Flow Factor Cv	Dimensions Dia.	L
1/4	ME002A	1.0	.81 (21)	1.84 (47)

Performance Characteristics

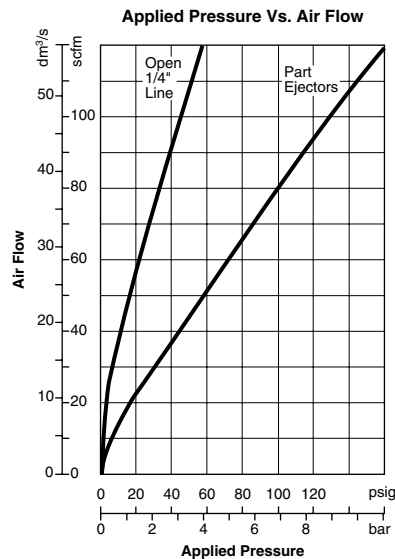



Miniature Control Devices and Pneumatic Accessories

2-Way and 3-Way Selector Valves	FIT-9-2
Noncontact Sensors	FIT-9-4
Contact Sensors	FIT-9-6
Rotowink Indicators	FIT-9-8
Differential Pressure Indicators	FIT-9-10
Pressure Switch	FIT-9-11
Diaphragm Amplifiers	FIT-9-12
Boostermites	FIT-9-14
Miniature Check Valves	FIT-9-16
Miniature Inline Restrictors	FIT-9-18
Miniature Inline Filters	FIT-9-19
High Pressure Needle Valves	FIT-9-20
Regulated Blow Guns	FIT-9-22
Fittings and Circuit Accessories	FIT-9-23

2-Way and 3-Way Selector Valves

- 2-, 3-, 6-, and 10- position models
- Common inlet connected to selected outlet port (multiple choices)
- Unselected ports blocked (2-way) or vented to atmosphere (3-way)
- Panel mount construction with numbered index ring (10-position models)
- Knob positions detented
- Applications include function and output selection, system programming, and pressure monitoring



Specifications

Fluid: Compressed air, nitrogen, or inert gases
 Pressure Range: Vacuum to 125 psig (8.6 bar)
 Temperature Range: 35° to 150°F (2° to 66°C)
 Port Size: 10-32 UNF
 Equivalent Orifice Size: Ø0.050" (1.3 mm)
 Flow Capacity: .75 scfm (.35 dm³/s) @ 10 psi (.7 bar) differential
 Recommended Filtration: 25µ
 Panel Mount Mounting Hole: Ø1.22" (31 mm)
 Max. Panel Thickness: 0.25" (6.3 mm)

Materials of Construction

Body: 2-,3- & 6-position: Acetal
 10-position: Aluminum
 Knob, panel nut: Acetal
 Elastomers: Buna-N

Options

Special versions of the selector valves are available, please consult factory with specific requirements and quantities.

Ordering Information

To order, quote appropriate product number from the tables on the following pages, e.g. 5CV-036-000 for 6-position, 3-way selector valve, 10-32 female back ported.

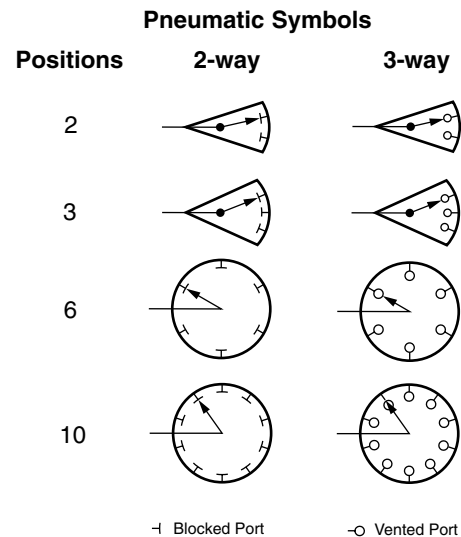

2-Way and 3-Way Selector Valves

All Dimensions in Inches (mm)



Positions	Part Number		Outlets	Port Location
	2-Way	3-Way		
2	5CV-022-000	5CV-032-000	2	Back
3	5CV-023-000	5CV-033-000	3	Back
6	5CV-026-000	5CV-036-000	6	Back
10	5CV-010-000	5CV-100-000	10	Back
10	5CV-011-000	5CV-110-000	10	Radial

Furnished with adapters for use with 1/16" ID flexible tubing.

10-position valves are furnished with three stop pins which can be inserted into holes provided in the valve body and underside of the selector knob to limit the number of usable positions.

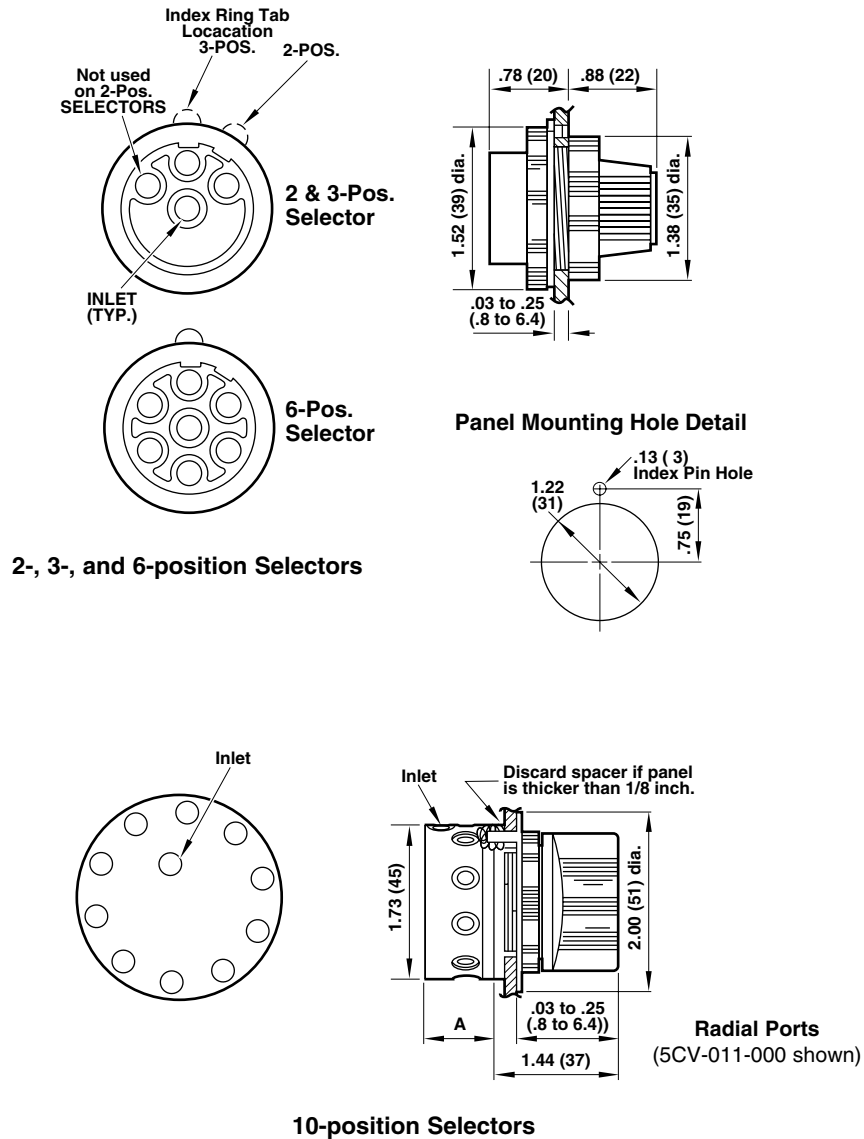

Part Number	A
5CV-010-000 & 5CV-100-000	1.00 (25.4)
5CV-011-000 & 5CV-110-000	0.91 (23.1)

- **Ideally suited for use in hazardous atmospheres**
- **Generates a pneumatic signal, indicating the presence or absence of an object**
- **Operates small directional control valves, pneumatic devices, or in logic circuits**
- **No moving parts**
- **Not subject to wear or fatigue, fast operating speed, long term reliability**
- **Ease of maintenance**

Operation

Typically applied where physical contact with an object is undesirable. These sensors generate a low level pneumatic signal which must be amplified to obtain a usable output and pressure level. Use a Diaphragm Amplifier (FIT-9-12) when driving into a logic circuit. Use a Boostermite (FIT-9-14) when operating valves or other pneumatic devices. The Diaphragm Amplifier or Boostermite also serve to isolate the remainder of the circuit from contaminants which might enter the sensor.

Proximity Sensor

A focused air-jet sensor which generates a positive pneumatic output signal whenever an object comes within close proximity of its face without making actual contact. Output (recovery) pressure versus sensing distance is shown in the graph (opposite page). For maximum output pressure, the surface of the sensed object should be parallel to the face of the sensor. This sensor is ideally suited for sensing fragile objects and those having irregular surfaces. Constructed of aluminum and Buna-N.

Interruptible Jet Sensor

Features a 1/4" sensing gap with an air-jet emitter on one side and a receiver on the other. It is a "normally on" device and an object passing through the gap will interrupt the sensor output signal. The sensor can also be used in conjunction with an external emitter (see below) for sensing across larger gaps. Constructed of aluminum.

Impacting Jet Sensor

Similar to the Interruptible Jet Sensor except it has a 1/2" sensing gap and a constant purge of the receiver port to minimize the entry of contaminants. It can also be used with an external emitter (see below) for sensing across larger gaps. Constructed of aluminum and brass.

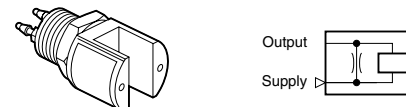
Emitter

A special jet generator for use with the Interruptible or Impacting Jet Sensors to sense across gaps of up to six inches (at 10 psig [.69 bar] supply pressure). The Emitter must be aimed so that its air-jet intersects the air-jet across the sensor and interrupts the sensor output signal. For maximum sensing distance, the sensor should be turned 90° so that the Emitter air-jet passes through the sensor gap from side to side rather than directly into the gap from the open end. An object passing between the Emitter and its associated sensor will deflect the Emitter air-jet and allow the sensor to generate a positive output signal. Constructed of aluminum.

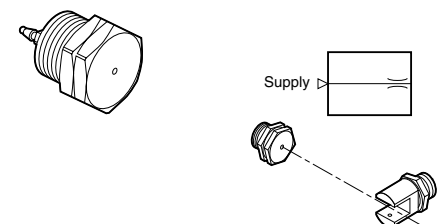
Accessories

Mounting Bracket: 4SM-010-000



Specifications

Fluid: Compressed air, nitrogen, or inert gases
 Recommended Supply Pressure: 10 psig (.69 bar)
 Maximum Supply Pressure: 30 psig (2.1 bar)
 Sensor Turn Off Pressure: < .05" H₂O (1.3 mbar)
 Temperature Range: 0° to 175°F (-18° to 79°C)
 Ports: 10-32 UNF (female)

Part Number	Sensor Description	Air Consumption scfm (dm ³ /s)	Output Pressure "H ₂ O (mbar)
4PS-010-D00	Proximity	.36 (.17)	See Chart
4JS-010-D00	Interruptible Jet	.13 (.06)	≥10 (25)
4JS-020-D00	Impacting Jet	.16 (.08)	≥10 (25)
4JS-030-D00	Emitter	.45 (.21)	—

All sensors have external mounting threads and are furnished with mounting nuts and plastic adapter fittings for 1/8" and/or 1/16" ID flexible tubing.

4PS-010-D00

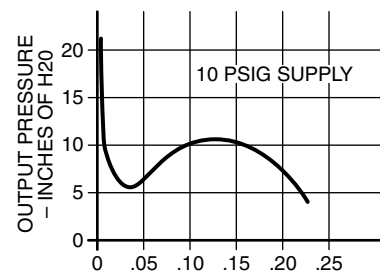
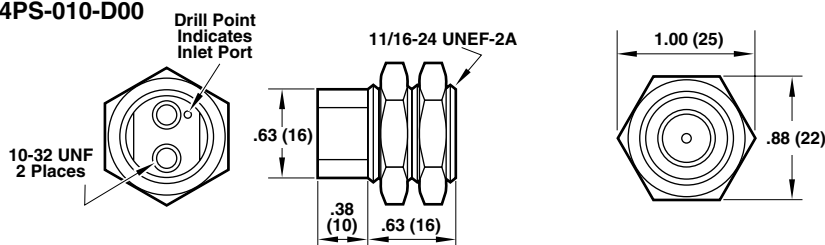

4JS-010-D00

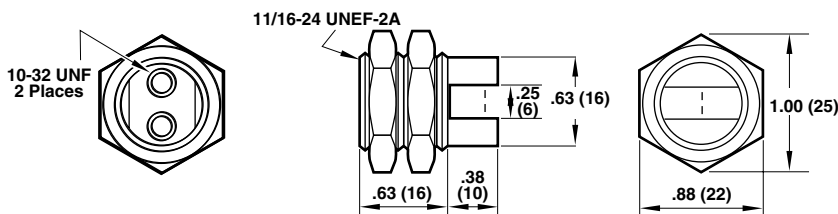

Sensing Distance - inches to normal surface
 (Range is reduced slightly for curved or angled surfaces.)

4JS-020-D00

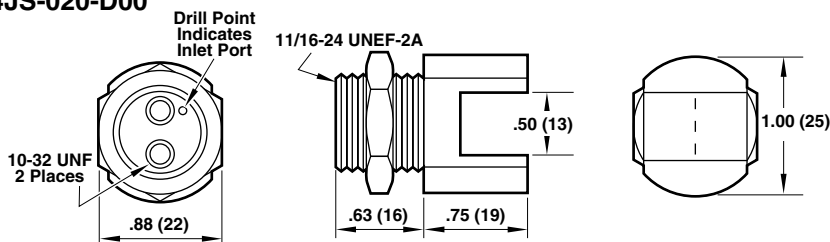

4SM-010-000

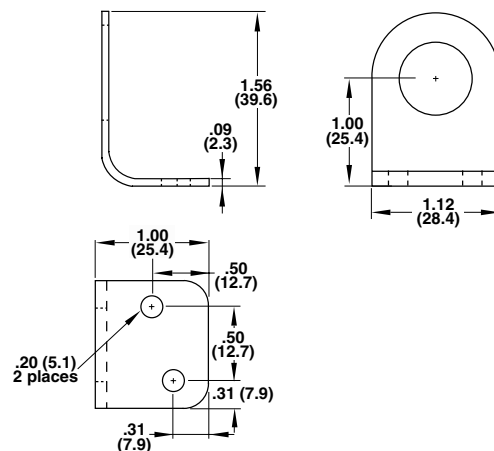

4JS-030-D00

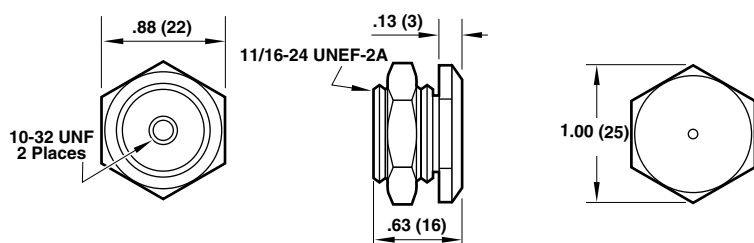

- Generates a pneumatic signal, indicating the presence or absence of an object
- Operates small directional control valves, pneumatic devices, or in logic circuits
- Internal inlet port filter

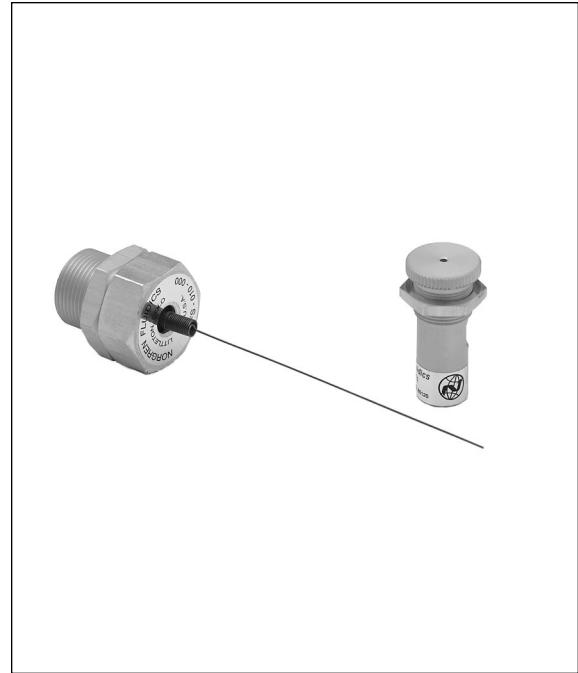
Operation:

The Featherflex Sensor is a miniature 3-way valve with a low force, flexible feather (wire whisker) actuator. It can be used in most applications where limit switches or limit valves would normally be used and is also ideal for use as a tension sensor. The Touch Sensor is a back pressure device for use as a manual input control or as a machine operated limit sensor. Each sensor has an inlet filter to protect its inlet orifice. The output of either sensor, at 10 psig (6.9 bar) can be used to drive logic devices. They can also be used with a power amplifier such as a Boostermite for direct operation of air-piloted control valves, small cylinders, and other pneumatic devices.

Featherflex Sensor

A "normally off", bleed type 3-way valve generates an output signal only when the feather is deflected. The actuation force is only 0.1 inch/ounce of torque. Typically, a 20° deflection of the feather in any direction will give full output. The Featherflex can be mounted in any attitude, but should be set back so that the outer 1/3 to 1/2 of the feather is contacted to insure full actuation. The feather can be trimmed back or bent into special shapes as the application may require. Constructed of aluminum, felt, brass, acetal, nylon, stainless steel and Buna-N.

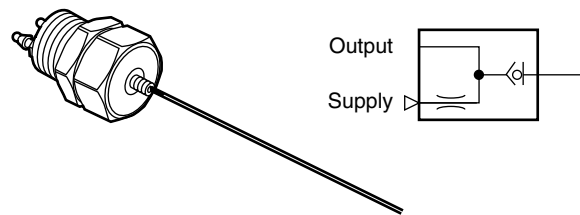
Touch Sensor

A back pressure device which generates an output signal whenever its exhaust flow is blocked by an object contacting the sensor face. It can be mounted in a Ø0.5" (12.7) hole in panels up to 0.25" (6.3 mm) thick, and actuated by finger tip, machine mounted and actuated by a slide, etc. Constructed of aluminum, felt, and brass.

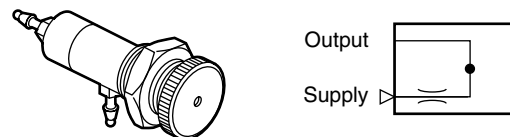
Specifications

Fluid: Compressed air, nitrogen, or inert gases
 Recommended Filtration: 5µ
 Recommended Supply Pressure: 10 psig (.69 bar)
 Maximum Supply Pressure: 30 psig (2.1 bar)
 Sensor Turn Off Pressure: < .05" H₂O (1.3 mbar)
 Temperature Range: 0° to 175°F (-18° to 79°C)
 Ports: 10-32 UNF (female)

Accessories

Mounting Bracket: Featherflex Sensor 4SM-010-000



Part Number	Sensor Description	Air Consumption scfm (dm ³ /s)	Output Pressure "H ₂ O (mbar)
5FS-010-D00	Featherflex	05 (.03)	†
4TS-011-DN0	Interruptible Jet	.03 (.02)	†

† When connected to a dead-ended load such as a Diaphragm Amplifier or Boostermite, the output pressure will equal the supply pressure. In such cases, the supply pressure must be limited to the maximum allowable control signal pressure for the particular amplifier or other device. All sensors have external mounting threads and are furnished with mounting nuts and plastic adapter fittings for 1/8" and/or 1/16" ID flexible tubing.

5FS-010-D00

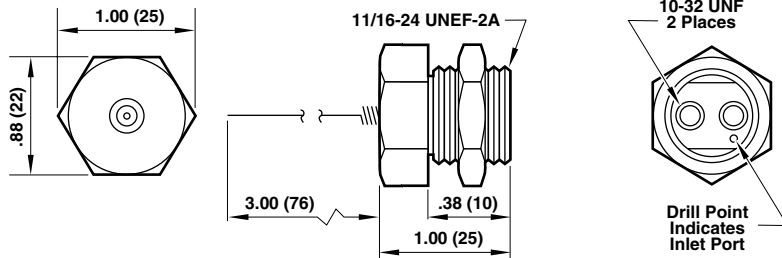

4TS-011-DN0

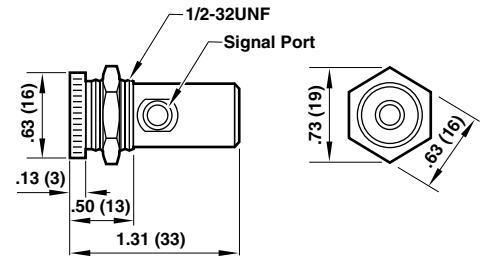

4SM-010-000

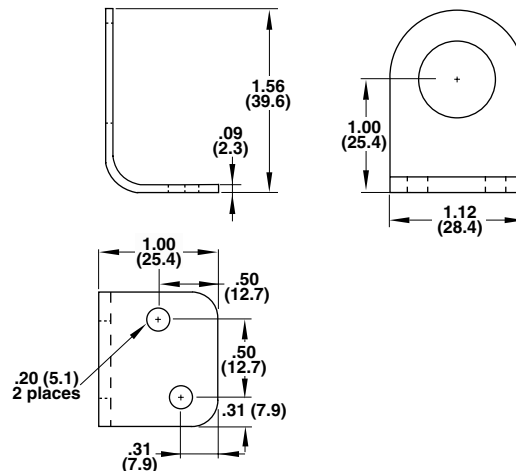

- **Visual indication of system status**
- **Indicate presence or absence of pressure**
- **Large (13/16") or small (7/16") lens**
- **Choice of connections**
- **Contrasting, fluorescent indicator colors**

Operation

Pressure applied to an internal piston/diaphragm assembly compresses a spring, moving a linkage which rotates the colored indicator ball. When full actuation pressure is reached, the indicator ball rotates fully, changing the indicator color.

When the pressure signal is removed, the internal spring returns the indicator ball to its non-actuated color/position.

**Specifications**

Fluid: Compressed air, nitrogen, or inert gases

Air Consumption: None

Working Pressure: See order chart FIT-9-9.

Temperature Range: 35° to 150°F (2° to 66°C)

Materials of Construction

Body:

5VS-1XX-XXX - Acetal

5VS-4XX-XXX - Polyphenylene

5VS-2XX-XXX - Acetal

End Plug:

5VS-1XX-XXX - Acetal

5VS-4XX-XXX - Aluminum

Piston: Acetal

Elastomer: Buna-N

Lens: Acrylic

Options

Special versions of the Rotowink are available, please consult factory with specific requirements and quantities.

Ordering Information

To order, quote appropriate product number from the tables on the following pages, e.g. 5VS-401-00 for 1/8 NPT female connection, black/red indication, and 10 psig actuation pressure.



Colors (Standard combinations listed. Other combinations available.)		Operating Pressure Ranges		
		1 to 15 psig (.07 to 1 bar)	10 to 125 psig (.7 to 8.6 bar)	15 to 150 psig (1 to 10.3 bar)
		NPT or UNF Thread Port		
Normal	Actuated	10-32 UNF* (Female)	1/8 NPTF (Female)	1/8 NPTF (Male)
Part Numbers				
Black	Red	5VS-101-000	5VS-401-000	5VS-201-000
Black	Green	5VS-102-000	5VS-403-000	5VS-202-000
Black	Yellow	5VS-103-000	5VS-403-000	-
Red	Green	5VS-112-000	5VS-412-000	5VS-212-000
Green	Red	5VS-121-000	5VS-421-000	5VS-221-000
Specifications				
Maximum Pressure - psig (bar)		15 (1)	125 (8.6)	150 (10.3)
Actuation Pressure - psig (bar)		1 (.07)	10 (.7)	15 (1)
Deactuation Pressure - psig (bar)		15" H2O (38 mbar)	2 (.14)	2 (.14)
Mounting Hole Ø - in. (mm)		.72 (18.3)	1.22 (31.0)	.72 (18.3)

*Furnished with an adapter for use with 1/16" ID flexible tubing.

5VS-1XX Series

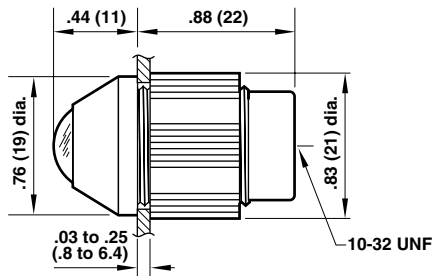

5VS-2XX Series

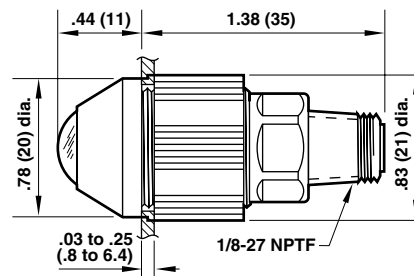

5VS-4XX Series

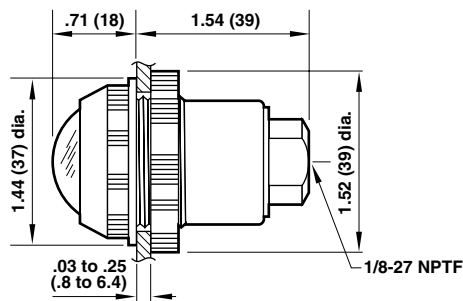

- Visual indication of differential pressure levels
- Full 360° visibility of RED/GREEN pressure indicator
- Light weight construction
- 1/8 NPT (female) connections
- In-line or bottom porting

Specifications

Fluid: Compressed air, nitrogen or inert gases
 Max. Inlet Pressure: 250 psig (17.2 bar)
 Temperature Range: 0° to 175°F (-18° to 79°C)
 Max. Differential Pressure: 15 psid (1 bar d)
 Ports: 1/8 NPT (female)

Materials of Construction

Indicator Body: Transparent nylon
 Adapter Body: Aluminum
 Internal Parts: Acetal
 Spring: Stainless steel
 Elastomers: Nitrile

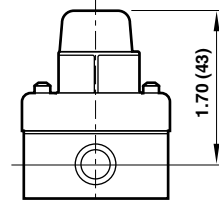
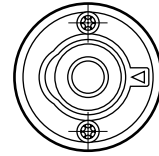

In-line Ported

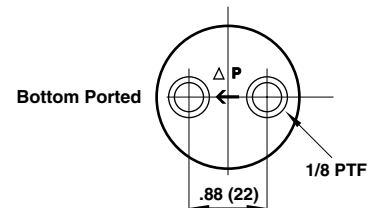
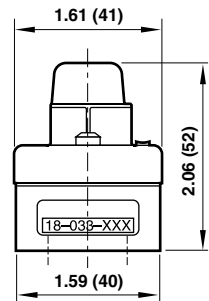

Part Number	Port Location	Differential Range	Indicator Color Code - (ΔP range)		
			GREEN	GREEN/RED	RED
18-033-104	In-line	0 to 5 psid (0 to 0.35 bar d)	less than 0.5 psid (0.04 bar d)	between 0.5 and 4.5 psi (0.04 and 0.31 bar d)	greater than 4.5 psid (0.31 bar d)
18-033-105	Bottom	0 to 10 psid (0 to 0.7 bar d)	less than 4 psid (0.3 bar d)	between 4 and 10 psid (0.3 and 0.7 bar d)	greater than 10 psid (0.7 bar d)
18-033-101	In-line	0 to 5 psid (0 to 0.35 bar d)	less than 0.5 psid (0.04 bar d)	between 0.5 and 4.5 psi (0.04 and 0.31 bar d)	greater than 4.5 psid (0.31 bar d)
18-033-102	Bottom	0 to 10 psid (0 to 0.7 bar d)	less than 4 psid (0.3 bar d)	between 4 and 10 psid (0.3 and 0.7 bar d)	greater than 10 psid (0.7 bar d)

Pressure Switch



- Integrates pneumatic and electrical systems
- Low actuation pressure
- Panel mountable
- Single-pole Double-throw operation
- May be wired Normally-open or Normally-closed

Pneumatic Symbol

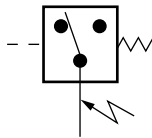

Operation:

Signal pressure extends a diaphragm which contacts and actuates an electrical micro-switch.

Specifications

Fluid: Compressed air, nitrogen, or inert gases
 Max. Working Pressure: 15 psig (1 bar)
 Actuation Pressure: 1 psig (.07 bar)
 Temperature Range: 35° to 150°F (2° to 66°C)
 Electrical Rating: 5 Amps 125/250 Vac
 Air Consumption: 0
 Panel Mounting Hole: Ø1-7/32" (31 mm)
 Panel Thickness: 0.03 to 0.25" (.8 to 6.4 mm)
 Connections
 Pneumatic: 10-32 UNF
 Electrical: 0.093 female spade (3x)

Materials of Construction

Body and Locknut: Aluminum
 Switch Carrier: Noryl
 Diaphragm: Polyurethane
 Diaphragm Plate: Nylon

Order Number - 5FE-010-000

Crimp type, insulated, male spade electrical terminals for 18-22 gauge wire are furnished with each switch.

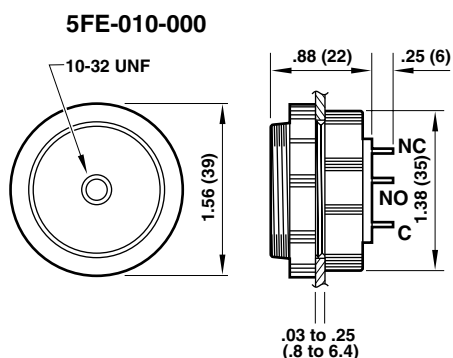

- **Miniature pneumatic interface amplifiers**
- **Sense very low pneumatic signals**
- **Provide on/off control of a high pressure air supply**
- **Low and ultra-low pressure models**
- **Used with non-contact sensors to amplify outputs to a usable level**
- **Serves as an output device in miniature pneumatic circuits**



Operation:

Supply pressure travels through an orifice and is vented to atmosphere. When a control signal is applied, it energizes a diaphragm, compressing a spring and cutting off the vent passage. Pressure is now directed from the supply to outlet port, providing an amplified signal. When the control signal is removed, the spring returns the diaphragm to its non-energized position, and the supply signal is once again vented to atmosphere.

Specifications

Fluid: Compressed air, nitrogen, or inert gases
 Max. Control Pressure: 5 psig (.3 bar)
 Inlet Pressure
 Minimum: 0 psig (0 bar)
 Maximum: 125 psig (8.6 bar)
 Temperature Range: 35° to 150°F (2° to 66°C)
 Equivalent Orifice Size: 0.014" (.36 mm)
 Cycle Rate: 25 Hz
 Ports: 10-32 UNF

Materials of Construction

Body: Noryl
 End Cap: Polycarbonate
 Spring: Stainless steel
 Diaphragm: Buna-N

Ordering Information

To order, quote appropriate product number from the tables on the following pages, e.g. 5DA-010-D0A for control of systems where actuation is required above a 4" H₂O signal with the output resetting to off when the control signal falls below 1" H₂O.

Pneumatic Symbol

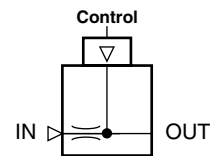

Diaphragm Amplifiers

All Dimensions in Inches (mm)

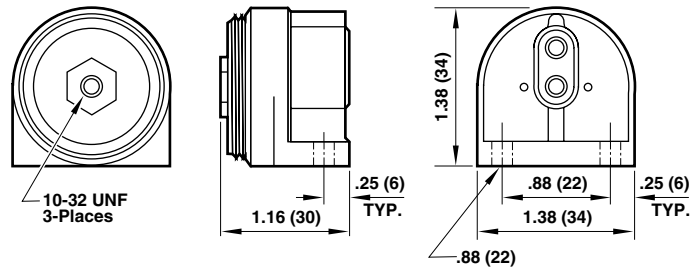

Part Number	Port Thread	Positive On/Off Actuation Points	
		ON - when control signal is more than:	OFF - when control signal is less than:
5DA-010-D0A	10-32 UNF	4" H ₂ O (10 mbar)	1" H ₂ O (2.5 mbar)
5DA-011-D0A	10-32 UNF	10" H ₂ O (25 mbar)	5" H ₂ O (12.5 mbar)

Furnished with three adapters for use with 1/16" ID flexible tubing.

- **Compact pneumatic power amplifiers**
- **Sense very low pneumatic signals**
- **Provide on/off control of a high pressure air supply**
- **Low and ultra-low pressure models**
- **Inputs (control) from pneumatic sensors, logic devices, instrumentation systems**
- **Provide direct operation of small actuators (cylinders), large air piloted valves, and other small pneumatic devices**
- **Average service life exceeding 100 million cycles**



Operation

Boostermites are bleed actuated, 2-position, 3-way, 3-port, normally closed poppet valves. Supply pressure travels through an orifice and is vented to atmosphere. When a control signal is applied, it energizes a diaphragm, compressing a spring and cutting off the vent passage. Pressure is now directed from the supply to the poppet piston, which shifts the valve, connecting the inlet to the outlet ports. When the control signal is removed, the spring returns the diaphragm to its non-energized position, and the supply signal is once again vented to atmosphere, and the poppet piston shifts the valve to the non-actuated position.

Specifications

Fluid: Filtered (25 μ), lubricated or non-lubricated compressed air

Max. Control Pressure: 5 psig (.3 bar)

Inlet Pressure

Minimum: 20 psig (1.4 bar)

Maximum: 125 psig (8.6 bar)

Temperature Range: 35° to 150°F (2° to 66°C)

Equivalent Orifice Size: 0.094" (2.4 mm)

Cycle Rate: 900 cpm

Ports

Control: 10-32 UNF

Main: 1/8 PTF

Materials of Construction

Body: Aluminum

Piston Assembly: Aluminum, Acetal

End Caps: Polycarbonate, Nylon

Springs: Stainless steel

Elastomers: Buna-N

Service Kit (includes seals) Part Number: P0150A-01

Ordering Information

To order, quote appropriate product number from the tables on the following pages, e.g. 5BV-011-D0A for operation of pneumatic devices where actuation is required above a 3" H₂O signal with the output resetting to off when the control signal falls below 1/2" H₂O.

Pneumatic Symbol

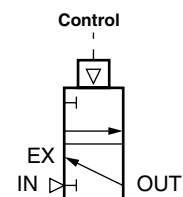



Part Number	Port Thread		Positive On/Off Actuation Points	
	Control	Main	ON - when control signal is more than*	OFF - when control signal is less than:
5BV-011-10A	10-32 UNF	1/8 PTF	3" H2O (7.5 mbar)	1/2" H2O (1.3 mbar)
5BV-010-10A	10-32 UNF	1/8 PTF	10" H2O (25 mbar)	5" H2O (12.5 mbar)

*Variation with attitude change: 1/2" H2O (1.3 mbar)

Furnished with two 1/2" long mounting spacers and a control port adapter for use with 1/16" ID flexible tubing.

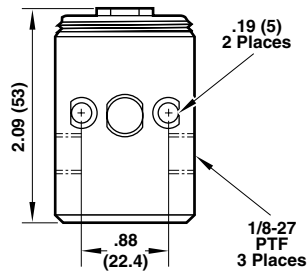
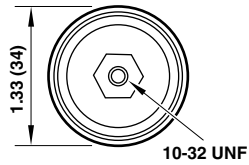

- Duckbill type check
- Non-venting
- Extremely low crack pressures
- 10-32 UNF or barbed tube connections
- Direct in-line mounting
- Control flow direction in medical equipment, instrumentation systems, and in miniature pneumatic control systems

Specifications

Fluid: Compressed air, inert gases, nonflammable and nontoxic chemical solutions (must be compatible with materials of construction - consult factory if in doubt).

Maximum Pressure: 30 psig (2.1 bar)

Temperature Range: 35° to 150°F (2° to 66°C)

Maximum Reverse Air Flow at Indicated Pressure Differential

4LD-052 & 4LD-063: 0.05 scim @ 2" H₂O (@ 1 bubble every 2 seconds)

All other listed models: 6 scim @ 8.3" H₂O

Materials of Construction

Body: Aluminum or polypropylene

Duckbill: Epichlorohydrin or ethylene propylene

Ordering Information

To order, quote appropriate product number from the tables on the following pages, e.g. 4LD-010-D00 for 10-32 UNF porting, 8" H₂O crack pressure, Epichlorohydrin duckbill, and aluminum body with 200 x 200 mesh stainless steel inlet filter.

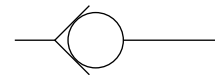
WARNING

These check valves must not be used where pressure or temperature may exceed rated operating conditions. See **Specifications**.

Fluids used in these check valves must be compatible with materials of construction. Consult factory if in doubt. These check valves are not intended for use in life support systems.

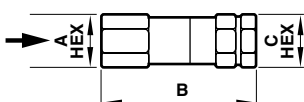
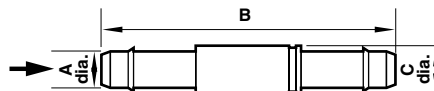
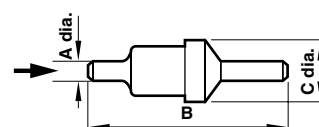
4LD-010-D00

4LD-020-B00

4LD-050/064-D00

Miniature Check Valves

All Dimensions in Inches (mm)



Part Number	Connection	Dimensions			Materials of Construction		Crack* Pressure
		A Inch (mm)	B Inch (mm)	C Inch (mm)	Duckbill	Body	
4LD-010-D00+	10-32 UNF	.25 (6.35)	.94 (23.9)	.25 (6.35)	Epichlorohydrin	Aluminum**	8" H2O
4LD-050-D00	1/16" ID Flexible Tube	.11 (2.8)	1.14 (29.0)	.34 (8.6)	Epichlorohydrin	Polypropylene	8" H2O
4LD-051-D00	1/16" ID Flexible Tube	.11 (2.8)	1.14 (29.0)	.34 (8.6)	Ethylene Propylene	Polypropylene	8" H2O
4LD-052-D00	1/16" ID Flexible Tube	.11 (2.8)	.99 (25.1)	.34 (8.6)	Ethylene Propylene	Polypropylene	8" H2O
4LD-020-B01	1/8" ID Flexible Tube	.19 (4.8)	1.56 (39.6)	.25 (6.35)	Epichlorohydrin	Aluminum**	8" H2O
4LD-063-D00	1/8" ID Flexible Tube	.15 (3.8)	1.58 (40.1)	.64 (16.3)	Ethylene Propylene	Polypropylene	3" H2O
4LD-064-D00	5/32" ID Flexible Tube	.18 (4.6)	1.70 (43.2)	.64 (16.3)	Ethylene Propylene	Polypropylene	3" H2O

*Pressure required to produce .001 scfm (28.3 cc/m) forward air flow.
 **This check valves has a 200 x 200 mesh, stainless steel inlet filter screen to protect the duckbill.
 +Furnished with two adapters for use with 1/16" ID flexible tubing.

Performance Characteristics

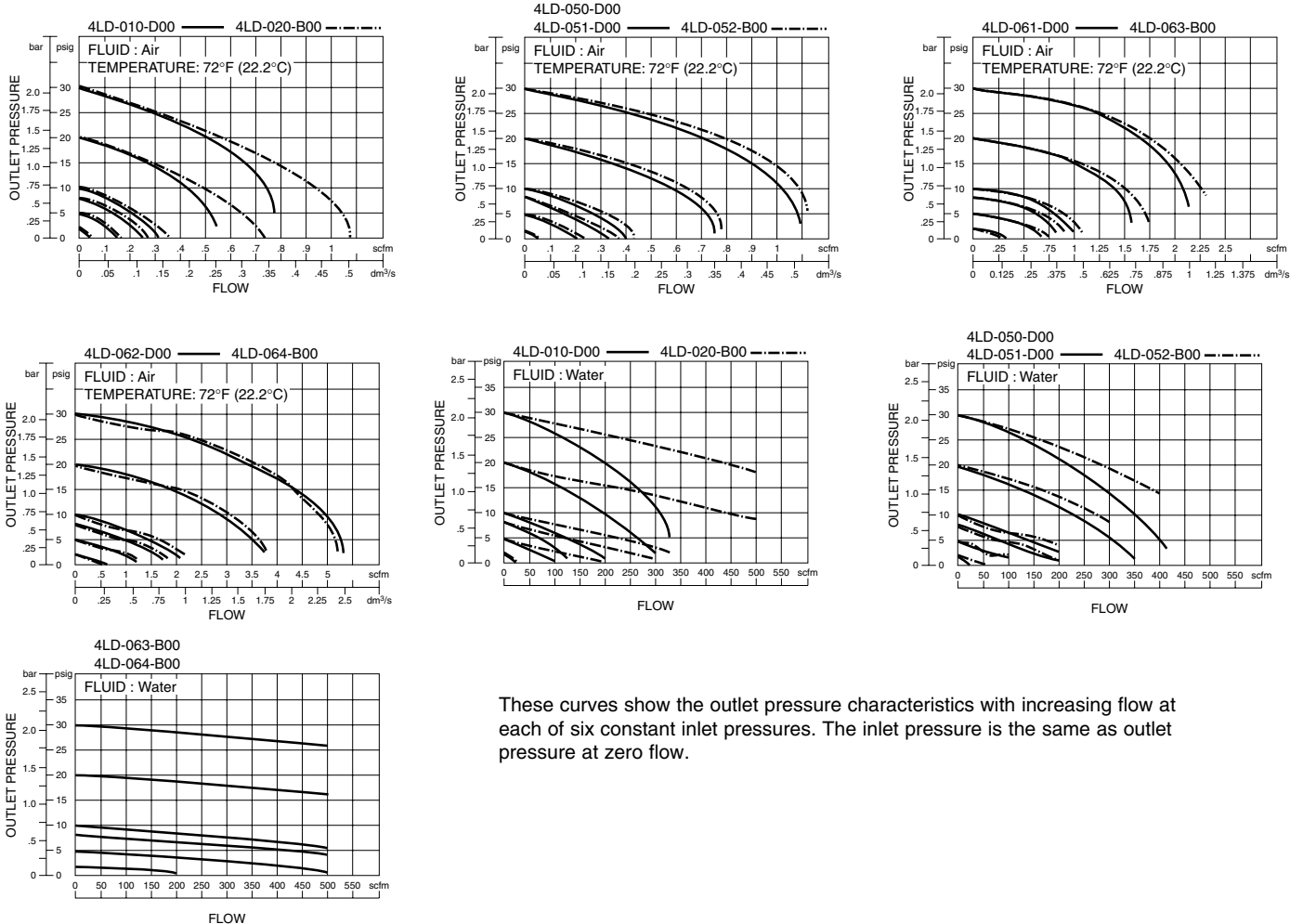

These curves show the outlet pressure characteristics with increasing flow at each of six constant inlet pressures. The inlet pressure is the same as outlet pressure at zero flow.

Miniature Inline Restrictors

- Provide “resistor” function in pneumatic circuits
- High precision sapphire orifices
- Color coded aluminum body with internal 200 x 200 mesh stainless steel prefilter
- 10-32 UNF or barbed tube connections
- Direct in-line mounting
- Signal attenuation and time delay functions in miniature pneumatic circuits

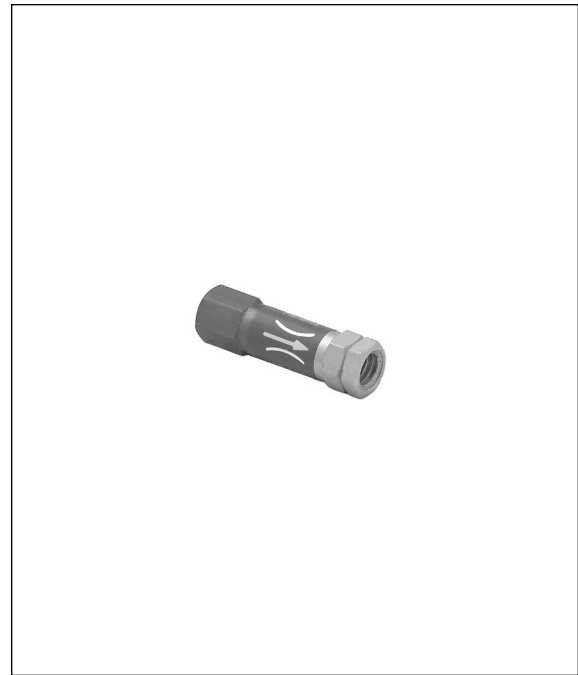

Specifications

Fluid: Compressed air, nitrogen or inert gases
 Maximum Pressure: 125 psig (8.6 bar)
 Temperature Range: 35° to 150°F (2° to 66°C)

Materials of Construction

Body: Aluminum
 Orifice: Sapphire
 Screen: Stainless steel

Pneumatic Symbol

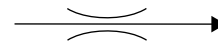

Part Number	Orifice Inch (mm)	Color Code
4LR-010-D04	0.004 (.10)	Yellow
4LR-010-D06	0.006 (.15)	Brown
4LR-010-D08	0.008 (.20)	Red
4LR-010-D10	0.010 (.25)	Black
4LR-010-D12	0.012 (.30)	Blue
4LR-010-D16	0.016 (.40)	Green

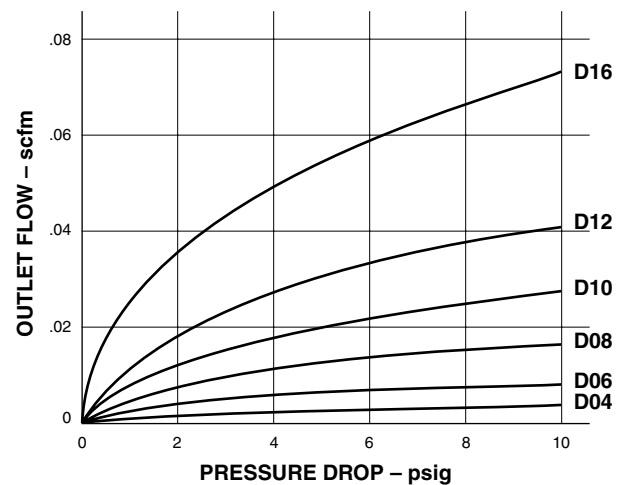
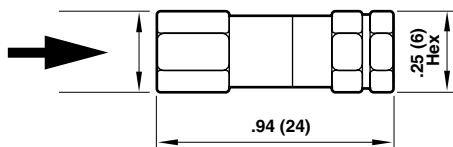

Miniature Inline Filters



- 25-micron element rating
- Connections for 1/8" or 5/32" ID flexible tubing
- Direct in-line mounting
- Protection against particulate contamination for miniature pneumatic systems

Specifications

Fluid: Compressed air, nitrogen or inert gases
 Element Rating: 25 μ
 Maximum Pressure: 60 psig (4.1 bar)
 Maximum Temperature: 125°F (52°C)

Materials of Construction

Body: Polypropylene
 Element: Sintered Bronze
 Elastomers: Buna-N

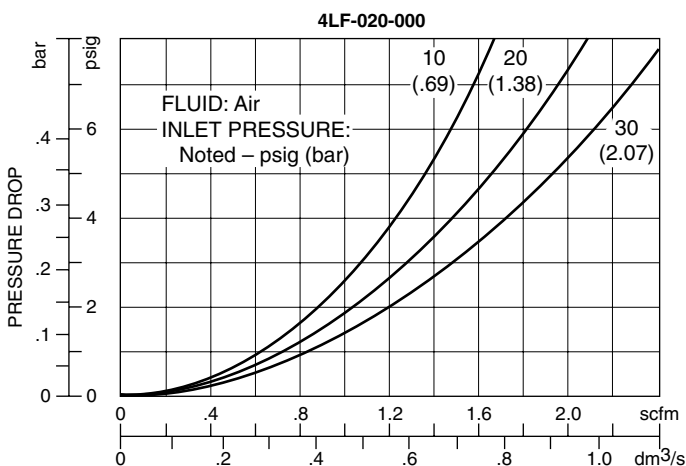
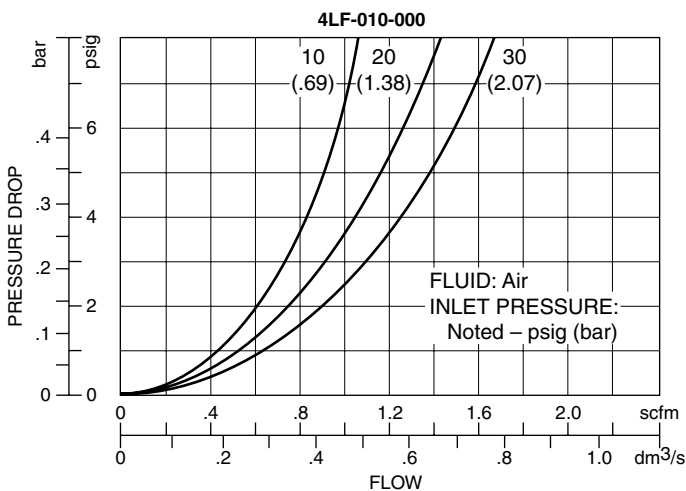

Pneumatic Symbol

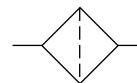

Part Number	Flexible Tube Connection
4LF-010-000	1/8" ID
4LF-020-000	5/32" ID

Part Number	ØA	ØC	B
4LF-010-000	0.15 (3.8)	0.64 (6.3)	1.58 (40.1)
4LF-020-000	0.18 (4.6)	0.64 (16.3)	1.70 (43.2)

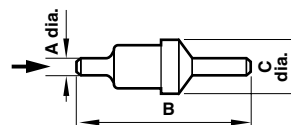

High Pressure Needle Valves

- Bar stock machined brass body
- Tapered brass needle
- Adjustable stem packing nut with Teflon® seal
- Retained adjustment stem
- Metal to metal sealing surfaces
- Accurate metering of fluids
- 3,000 psig inlet pressure



Specifications

Fluid: Compressed air, water, steam, and other non-flammable, inert gases and liquids

Max. Inlet Pressure: 3,000 psig (207 bar)

Temperature Range: -40° to 500°F (-40° to 260°C)

Max. Differential Pressure: 15 psid (1 bar d)

Ports: 1/8 or 1/4 NPT

Orifice Size: Ø0.187" (5 mm)

CV: 0.401

Materials of Construction

Body, needle, packing nut, knob: Brass

Stem Seal: Teflon®

Ordering Information

To order, quote appropriate product number from the tables on the following pages, e.g. 17-001-106 for 1/8 NPT male ported needle valve.

High Pressure Needle Valves

All Dimensions in Inches (mm)



Size (NPT)	Port		Part Number	Dimensions			
	In	Out		A	B	Closed	Open
1/8	Male	Male	17-001-106	1.63 (41)	0.38 (10)	2.13 (54)	2.25 (57)
	Female	Female	17-001-109	1.63 (41)	0.38 (10)	2.13 (54)	2.25 (57)
	Female	Male	17-001-112	1.63 (41)	0.38 (10)	2.13 (54)	2.25 (57)
1/4	Male	Male	17-001-107	1.81 (46)	0.38 (10)	2.13 (54)	2.25 (57)
	Female	Female	17-001-110	1.63 (41)	0.38 (10)	2.13 (54)	2.25 (57)
	Male	Female	17-001-114	1.72 (44)	0.38 (10)	2.13 (54)	2.25 (57)

17-001-106
17-001-107

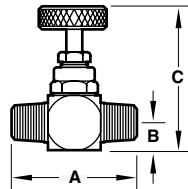

17-001-109
17-001-110

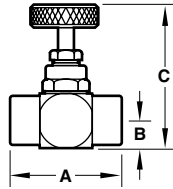

17-001-112
17-001-114

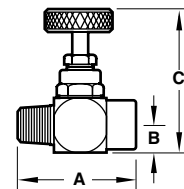

Fluid: Air
Outlet Pressure: Atmosphere
Adjustment Knob: Full Open

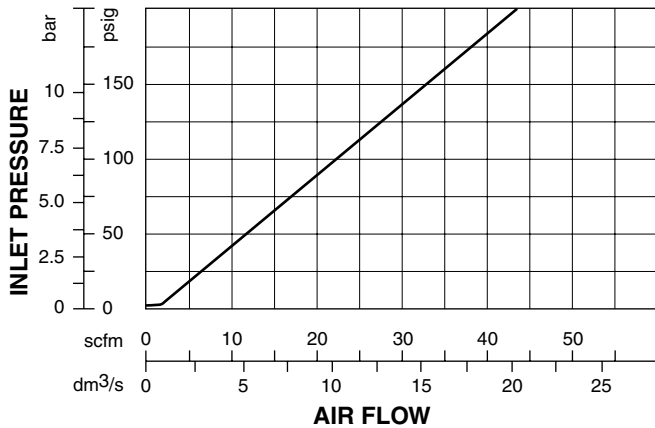

Fluid: Water
Outlet Pressure: Atmosphere
Adjustment Knob: Full Open

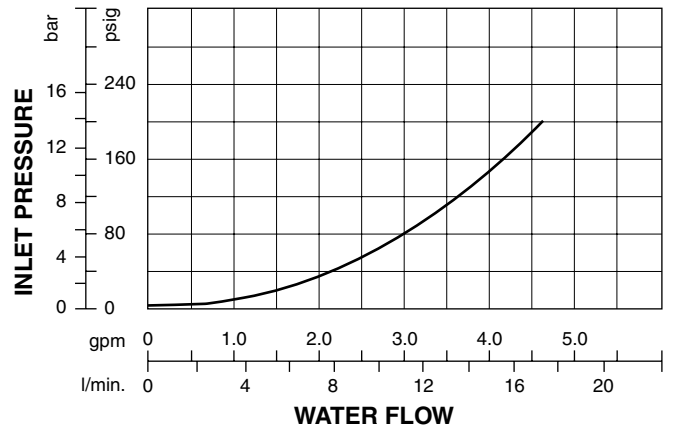

- Nozzle pressure regulated to below 30 psig, even if nozzle is obstructed
- OSHA compliant
- Large lever for comfort and easy actuation
- Permanently assembled, tamper resistant construction
- Surface scratching reduced by ordering model with rubber tipped nozzle
- Tips may be replaced or exchanged
- 10" and 18" extension nozzles available

Specifications

Fluid: Compressed air
 Maximum Inlet Pressure: 250 psig (17.2 bar)
 Temperature Range: 32° to 175°F (0° to 79°C)
 Outlet (Regulated) Pressure: Below 30 psig (2.1 bar)
 Nozzle Orifice: Ø0.16" (Ø4 mm)
 Port Size: 1/4 PTF (female)

Materials of Construction

Body: Polyester
 Nozzle Tip: Metal (aluminum or brass) or Rubber
 Elastomers: Nitrile

Accessories

Hanging Hook: 5320-01
 10" Extension Nozzle: 5363-50
 18" Extension Nozzle: 5363-51







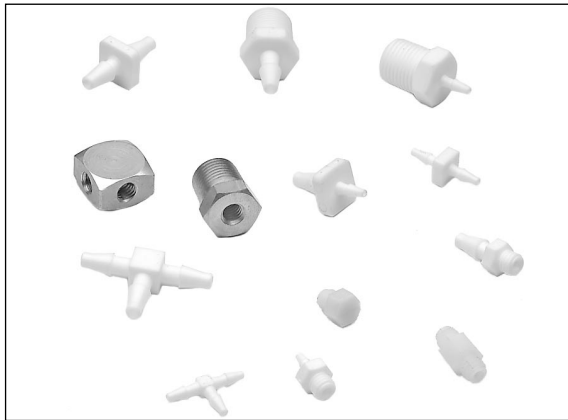



Replacement Parts

Nozzle with Air Shield: 1135-05
 Nozzle without Air Shield: 1135-06
 Nozzle Rubber Tip: 1135-07

Port (PTF)	Part Number	Nozzle Type
1/4	17-104-302	Metal Tip with Air Shield
1/4	17-104-304	Metal Tip
1/4	17-104-306	Rubber Tip

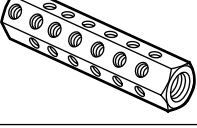

- Ideal for use with 1/16" ID or 1/8" ID polyurethane tubing
- Barbed connection for 1/16" or 1/8" ID tubing 10-32 UNF and 1/8 PTF threads
- Facilitates the expedient connection of miniature pneumatic components

	Component	Part Number	Description	Material	Max. Press psig (bar)	Qty/bag
	Male Connector	4TC-020-050	10-32 UNF x 1/16" ID tube	Nylon	125 (8.6)	50
		4TC-021-050	10-32 UNF x 1/8" ID tube	Nylon	30 (2.1)	
	Male Bleed Connector	4TC-010-025	10-32 UNF x 1/16" ID tube with Ø.008" to .012" (.2 to .3) bleed to atmosphere Color coded red	Nylon	125 (8.6)	25
	Male Hex Nipple	4TC-022-050	10-32 UNF male	Nylon	125 (8.6)	50
	Hex Plug	4TC-023-050	10-32 UNF male	Nylon	125 (8.6)	50
	Female Cross Connector	4LC-010-000	10-32 UNF Female (4x)	Aluminum	125 (8.6)	5
	Female Bulkhead Connector	4BC-020-000	10-32 UNF Female (2x). Fits Ø.34" (8.6) hole, 0.25" (6.4) maximum panel thickness.	Aluminum	125 (8.6)	5
	Bushing	4BR-010-000	1/8 PTF (male) x 10-32 UNF (female)	Brass	125 (8.6)	5
	Female Bulkhead Connector	4BC-010-000	1/8 PTF (female) x 10-32 UNF (female). Fits Ø.53" (13.5) hole, 0.25" (6.4) maximum panel thickness	Brass	125 (8.6)	2
	Distribution Manifold	4MC-010-118	1/8 PTF (female) inlet, 10-32 UNF (female) outlets (18x). 5/8" (16) hex x 3.07" (78.0) long. Ø.20 (5.1) mounting hole - opposite inlet end.	Aluminum	125 (8.6)	1
	Union	4TC-041-025	1/16" ID tube	Nylon	125 (8.6)	25
	Union	4TC-043-025	1/8" ID tube	Nylon	30 (2.1)	
	Union - Reducing	4TC-042-025	1/8" ID x 1/16" ID tube	Nylon	30 (2.1)	
	Union Tee	4TC-039-025	1/16" ID tube	Nylon	125 (8.6)	
		4TC-040-025	1/8" ID tube	Nylon	30 (2.1)	
	Male Connector	4TC-035-025	1/8 PTF x 1/16" ID tube	Nylon	125 (8.6)	
		4TC-036-025	1/8 PTF x 1/8" ID tube	Nylon	30 (2.1)	

Conversion Factors and Part Number Index



Conversion FactorsFIT-10-2
Chemical Resistance ChartFIT-10-3
Numerical Part IndexFIT-10-5
Warning and WarrantyFIT-10-6



Conversion Factors

VOLUME

from/to	cm ³	liter	in ³	ft ³	fl oz	pt.	qt.	gal
cm ³	1	.001	0.06102	3.53 x 10 ⁻⁵	.03381	.00211	0.106	2.64 x 10 ⁻⁶
liter	1000	1	61.02	0.03532	33.81	2.113	10.057	.2642
in ³	16.39	0.01639	1	5379 x 10 ⁻⁴	.5541	.03463	0.01732	.00433
ft ³	2.83 x 10 ⁴	28.32	1728	1	957.5	59.84	29.92	7.481
fl oz	29.57	0.02957	1.805	0.00104	1	.06250	.03125	.00781
pt	473.2	0.4732	28.88	0.01671	16	1	0.500	0.1250
qt	946.4	0.9463	57.75	0.03342	32	2	1	0.2500
gal (US)	3785	3.785	231	0.1337	128	8	4	1

TEMPERATURE COMPARISON

-100°C to +300°C			
°C	°F	°C	°F
-100	-148	29	84.2
-90	-130	30	86.0
-80	-112	31	87.8
-70	-94	32	89.6
-60	-76	33	91.4
-50	-58	34	93.2
-40	-40	35	95.0
-35	-31	36	96.8
-30	-22	37	98.6
-25	-13	38	100.4
-20	-4	39	102.2
-15	5	40	104.0
-10	14	45	113
-5	23	50	122
0	32	55	131
1	33.8	60	140
2	35.6	65	149
3	37.4	70	158
4	39.2	75	167
5	41	80	176
6	42.8	85	185
7	44.6	90	194
8	46.4	95	203
9	48.2	100	212
10	50	110	230
11	51.8	120	248
12	53.6	130	266
13	55.4	140	284
14	57.2	150	302
15	59	160	320
16	60.8	170	338
17	62.6	180	356
18	64.4	190	374
19	66.2	200	392
20	68	210	410
21	69.8	220	428
22	71.6	230	446
23	73.4	240	464
24	75.2	250	482
25	77	260	500
26	78.8	270	518
27	80.6	280	531
28	82.4	290	554
		300	572

PRESSURE

from/to	mm Hg	in Hg	in H ₂ O	ft H ₂ O	atm	lb/in ²	kg/cm ²
mm Hg	1	0.03937	0.5353	0.04460	.00132	0.01934	.00136
in Hg	25.40	1	13.60	1.133	.03342	0.4912	0.03453
in H ₂ O	1.868	0.07355	1	0.08333	0.00246	0.03613	0.00254
ft H ₂ O	22.42	0.8826	12	1	0.02950	0.4335	0.03048
atm	760	29392	406.8	33.9	1	14.70	1.033
lb/in ²	51.71	2.036	27.67	2.307	0.06805	1	0.07031
kg/cm ²	735.6	28.96	393.7	32.81	0.9678	14.22	1
bar	750.0	29.53	401.32	33.46	0.98592	14.504	1.01978
MPa	7500	295.3	4013.2	334.6	9.8592	145.04	10.1978

LENGTH

from/to	cm	m	km	in	ft.	mile
cm	1	0.01	1 x 10 ⁻⁵	0.3937	0.03281	6.21 x 10 ⁻⁶
m	100	1	0.001	39.37	3.281	6.21 x 10 ⁻⁴
km	1 x 10 ⁵	1000	1	3.94 x 10 ⁴	3281	0.6214
in	2.540	0.02540	2.54 x 10 ⁻⁵	1	0.08333	1.58 x 10 ⁻⁵
ft	30.48	0.3048	3.05 x 10 ⁻⁴	12	1	1.89 x 10 ⁻⁴
mile	1.61 x 10 ⁵	1609	1.609	6.34 x 10 ⁴	5280	1

ENERGY

from/to	BTU	Cal	Joule	Hp. hr.	Kw hr.
BTU	1	252.0	1055	3.93 x 10 ⁻⁴	2.93 x 10 ⁻⁴
Cal	0.397	1	4.186	1.56 x 10 ⁻⁵	1.16 x 10 ⁻⁵
joule	9.48 x 10 ⁻⁴	0.2389	1	3.73 x 10 ⁻⁷	2.78 x 10 ⁻⁷
Hp hr	2545	6.41 x 10 ⁵	2.68 x 10 ⁶	1	0.7457
Kw hr	3413	8.60 x 10 ⁵	3.60 x 10 ⁶	1.341	1

AREA

from/to	cm ⁴	m ²	km ²	in ²	ft ²
cm ²	1	0.0001	1 x 10 ⁻¹⁰	0.1550	0.00108
m ²	1 x 10 ⁴	1	1 x 10 ⁻⁵	1550	10.76
km ²	1 x 10 ¹⁰	1 x 10 ⁵	1	1.55 x 10 ⁹	1.08 x 10 ⁷
in ²	6.452	6.45 x 10 ⁻⁴	6.45 x 10 ⁻¹⁰	1	0.00694
ft ²	929.00	0.09290	9.29 x 10 ⁻⁸	144	1

TEMPERATURE CONVERSION

$$\begin{aligned}
 ^\circ\text{C} &= 5/9 (^\circ\text{F} - 32) \\
 ^\circ\text{F} &= 9/5 (^\circ\text{C} + 32) \\
 ^\circ\text{K} &= ^\circ\text{C} + 273.2 \\
 ^\circ\text{R} &= ^\circ\text{F} + 459.7
 \end{aligned}$$

FLOWS

from/to	1 scfm	1 L/min	1 cm ³ /sec	1 dm ³ /sec
1 scfm	1	28.32	471.95	.472
1 L/min	0.035	1	16.67	0.0167
1 cm ³ /sec	0.0021	0.06	1	.001
1 dm ³ /sec	2.1	0.00006	1000	1

WEIGHT

from/to	gm	kg	oz	lb
gm	1	0.001	0.03527	0.00220
kg	1000	1	35.27	2.205
oz	28.35	0.02835	1	0.06250
lb	453.6	0.4536	16	1

Chemical Resistance Chart



Key:

N = Nylon

PUR = Polyurethane

PE = Polyethylene

	N	PUR	PE		N	PUR	PE		N	PUR	PE
Acetic Acid, Glacial	-	4	1	Ethylene Chloride	-	4	3	Picric Acid	3	2	-
Acetic Acid, 30%	-	4	1	Ethylene Glycol	2	4	1	Potassium Acetate (aq)	-	4	-
Acetone	-	4	2	Ethylene Oxide	1	4	3	Potassium Chloride (aq)	-	1	1
Acetylene	-	4	1	Ethylene Trichloride	-	4	-	Potassium Cyanide (aq)	-	1	1
Alkazine	-	4	-	Ferric Chloride (aq)	-	1	1	Potassium Hydroxide (aq)	3	4	1
Aluminum Chloride (aq)	-	3	2	Ferric Nitrate (aq)	-	1	2	Producer Gas	-	1	1
Aluminum Nitrate (aq)	-	3	-	Ferric Sulfate (aq)	-	1	1	Propane	1	3	3
Ammonia Anhydrous	-	4	2	Fluorine (Liquid)	4	4	3	Propyl Alcohol	-	4	-
Ammonia Gas (cold)	-	3	-	Formaldehyde (RT)	-	4	2	Propylene	-	4	-
Ammonia Gas (hot)	-	4	-	Formic Acid	3	3	2	Propylene Oxide	-	4	-
Ammonium Chloride (aq)	-	1	1	Freon 11	-	4	3	Pydraul, 10E, 29 ELT	-	4	-
Ammonium Sulfate (aq)	-	1	1	Freon 12	1	1	3	Pydraul 30E, 50E, 65E	-	4	-
Amyl Alcohol	-	4	2	Freon 22	1	4	-	Pydraul, 115E	-	4	-
Amyl Naphthalene	-	4	-	Fuel Oil	-	2	3	Pydraul 230E, 312C, 540C	-	4	-
Animal Fats	-	1	-	Futural Glucose	-	4	1	Rapeseed Oil	-	2	-
Aqua Regia	-	4	2	Glue	-	1	1	Red Oil (MIL-H-5606)	-	1	-
Arsenic Acid	-	3	2	Glycerin	1	1	1	RJ-1 (MIL-F-23338 B)	-	1	-
Asphalt	-	2	1	Glycols	1	4	-	RP-1 (MIL-F-25576 C)	-	1	-
ASTM Fuel A	-	2	-	Green Sulfate Liquor	-	1	-	Salt Water	1-	2	1
ASTM Fuel B	-	3	-	Hexane	-	2	3	Sewage	-	4	-
ASTM Fuel C	-	3	1	Hydraulic Oil	-	1	1	Silicate Esters	-	1	-
Barium Chloride (aq)	-	1	1	Hydrochloric Acid (cold) 37%	-	4	2	Silicone Oils	-	1	1
Beer	1	2	1	Hydrochloric Acid (hot) 37%	-	4	-	Silver Nitrate	-	1	2
Beet Sugar Liquors	-	4	1	Hydrofluoric Acid (Conc.) Cold	-	3	-	Skydrol 500	-	4	-
Benzene	1	3	3	Hydrofluoric Acid (Conc.) Hot	-	4	-	Skydrol 700	-	4	-
Benzine	-	2	-	Hydrogen Gas	1	1	1	Soap Solutions	1	3	3
Blast Furnace Gas	-	4	-	Isobutyl Alcohol	-	4	-	Sodium Chloride (aq)	1	1	1
Bleach Solutions	-	4	-	Isooctane	-	2	-	Sodium Hydroxide (aq)	2	4	2
Borax	-	1	1	Isopropyl Acetate	-	4	2	Sodium Peroxide (aq)	-	4	1
Boric Acid	-	1	1	Isopropyl Alcohol	1	3	-	Sodium Phosphate (aq)	-	1	-
Brake Fluid	-	4	-	Isopropyl Ether	-	2	1	Sodium Sulfate (aq)	-	1	1
Brine	-	2	4	Kerosene	1	1	3	Soy Bean Oil	-	2	1
Bromine Water	4	4	-	Lacquers	-	4	2	Steam Under 300°F	4	4	-
Bunker Oil	-	2	-	Lacquer Solvents	-	4	2	Steam Over 300°F	4	4	-
Butane	1	1	3	Lard	-	1	2	Stoddard Solvent	-	1	3
Butter	-	1	-	Lavender Oil	-	4	-	Styrene	-	3	-
Butyl Alcohol	3	4	1	Lead Acetate (aq)	-	4	1	Sucrose Solution	-	4	-
Butylene	-	4	1	Linseed Oil	1	2	3	Sulfuric Acid (Dilute)	-	3	1
Calcium Chloride (aq)	1	1	2	Liquified Petroleum Gas	-	-	-	Sulfuric Acid (Conc.)	-	4	3
Calcium Hydroxide (aq)	-	1	2	Lubricating Oils	-	2	4	Sulfuric Acid (20% Oleum)	-	4	-
Calcium Nitrate (aq)	1	1	-	Lye	-	4	-	Sulfurous Acid	-	3	2
Calcium Sulfide (aq)	-	1	-	Magnesium Chloride (aq)	1	1	1	Tannic Acid	-	1	2
Cane Sugar Liquors	-	4	-	Magnesium Hydroxide (aq)	-	4	1	Tetrochloroethylene	-	4	2
Carbolic Acid	-	3	2	Mercury	1	1	1	Toluene	1	4	3
Carbon Dioxide	-	1	3	Methane	1	3	-	Transformer Oil	-	1	-
Carbonic Acid	-	1	2	Methyl Acetate	1	4	2	Transmission Fluid Type A	-	1	-
Carbon Monoxide	-	1	2	Methyl Acrylate	-	4	-	Trichloroethane	3	4	-
Carbon Tetrachloride	3	4	2	Methyl Alcohol	1	4	1	Trichloroethylene	3	4	3
Castor Oil	-	1	-	Methyl Butyl Ketone	-	4	-	Turbine Oil	-	1	3
Chlorine (dry)	4	4	2	Methyl Chloride	3	4	3	Turpentine	1	4	3
Chlorine (wet)	4	4	-	Methylene Chloride	-	4	3	Varnish	-	3	3
Chloroform	3	4	3	Methyl Ethyl Ketone	1	4	2	Vinegar	1	4	2
Chlorox	-	4	-	Methyl Isobutyl Ketone	1	4	-	Vinyl Chloride	-	4	-
Chromic Acid	4	4	1	Milk	1	4	1	Water	1	1	1
Citric Acid	1	1	1	Mineral Oil	1	1	2	Whiskey, Wines	1	2	3
Coal Tar	-	3	-	Naphtha	1	2	1	White Oil	-	1	-
Coconut Oil	-	2	-	Naphthaline	1	2	1	Wood Oil	-	3	-
Cod Liver Oil	-	1	-	Natural Gas	-	2	-	Xylene	2	4	3
Coke Oven Gas	-	4	-	Neatsfoot Oil	-	1	-	Zinc Acetate (aq)	-	4	-
Copper Chloride (aq)	-	1	2	Nitric Acid (Conc.)	4	4	3	Zinc Chloride (aq)	1	1	1
Copper Cyanide (aq)	-	1	2	Nitric Acid (Delute)	4	3	-				
Corn Oil	-	1	3	Nitroethane	-	4	-				
Cotton Seed Oil	-	1	2	Nitrogen	-	1	-				
Creosol	4	4	3	N-Octane	-	4	-				
Cyclohexane	1	1	2	Oleic Acid	1	2	3				
Denatured Alcohol	-	4	-	Oleum Spirits	-	3	4				
Detergent Solution	-	4	1	Olive Oil	-	1	1				
Diesel Oil	-	3	3	Oxygen - Cold	1	1	-				
Dioxane	-	4	-	Oxygen (200 - 400°F)	-	4	-				
Dowtherm Oil	-	3	-	Paint Thinner, Duco	-	4	-				
Dry Cleaning Fluids	-	4	-	Perchloric Acid	-	4	-				
Ethane	-	3	-	Perchloroethylene	3	4	4				
Ethyl Acrylate	-	4	-	Petroleum - Below 250°F	-	2	-				
Ethyl Alcohol	3	4	-	Petroleum - Above 250°F	4	4	-				
Ethyl Benzine	-	4	-	Phenol	4	3	2				
Ethyl Cellulose	-	2	-	Phenyl Ethyl Ether	-	4	-				
Ethyl Chloride	-	2	-	Phosphoric Acid - 45%	2	1	2				
Ethyl Ether	-	3	-	Pickling Solution	-	4	-				

Please note:

The following ratings are very general guidelines, designed only to be used as an initial screening tool. Dynamic vs. static application, temperature, chemical mixtures, and the specific tubing compound selected can significantly affect or change these ratings either positively or negatively. Careful testing under actual conditions is essential. Accuracy for these ratings is not given or implies.

Ratings: 1 = Little or no impact
 2 = Minor effect
 3 = Moderate effect
 4 = Severe effect

N = NYLON
 PUR = POLYURETHANE
 PE = POLYETHYLENE



Part Index

Part Number **Page Number**

48A	FIT-7-3
48B	FIT-7-3
48C	FIT-7-3
48D	FIT-7-3
10 008	FIT-6-8
10 009	FIT-2-30
10 010	FIT-2-36
10 011	FIT-2-29
10 015	FIT-2-28
10 019	FIT-2-36
10 020	FIT-1-6
10 020	FIT-2-11
10 020	FIT-2-10
10 022	FIT-2-11
10 023	FIT-1-13
10 029	FIT-2-14
10 040	FIT-2-14
10 043	FIT-2-15
10 049	FIT-2-15
10 051	FIT-2-35
10 060	FIT-2-16
10 071	FIT-2-35
10 082	FIT-2-17
10 0D6	FIT-2-38
10 115	FIT-1-19
10 115	FIT-2-22
10 124	FIT-2-20
10 125	FIT-1-12
10 125	FIT-2-19
10 145	FIT-2-25
10 147	FIT-2-27
10 167	FIT-2-29
10 168	FIT-2-32
10 1D6	FIT-2-38
10 215	FIT-2-21
10 225	FIT-2-18
10 226	FIT-2-24
10 247	FIT-2-26
10 257	FIT-2-33
10 267	FIT-2-28
10 268	FIT-2-30
10 2GA	FIT-3-27
10 2GB	FIT-3-24
10 2GD	FIT-3-29
10 415	FIT-1-19
10 415	FIT-2-23
10 425	FIT-1-16
10 425	FIT-2-20
10 A51	FIT-2-3
10 A71	FIT-2-26
10 K51	FIT-3-4
10 TA0	FIT-3-4
11 004	FIT-1-27
11 004	FIT-2-36
11 022	FIT-2-11
12 004	FIT-1-27
12 008	FIT-6-6
12 019	FIT-1-27
12 020	FIT-1-8/9
12 020	FIT 2-12
12 022	FIT-1-9
12 023	FIT-1-10
12 029	FIT-1-11
12 037	FIT-1-9
12 037	FIT-2-12
12 040	FIT-1-11
12 060	FIT-1-12
12 080	FIT-1-13
12 082	FIT-1-12
12 082	FIT-2-17
12 084	FIT-1-13
12 0D6	FIT-1-28
12 0D6	FIT-2-38
12 115	FIT-1-19
12 125	FIT-1-17
12 225	FIT-1-15
12 225	FIT-1-23

Part Number **Page Number**

12 247	FIT-1-23
12 415	FIT-1-18
12 415	FIT-1-19
12 415	FIT-2-23
12 424	FIT-1-17
12 425	FIT-1-14
12 425	FIT-1-16
12 425	FIT-2-20
12 426	FIT-1-20
12 432	FIT-1-16
12 445	FIT-1-20
12 447	FIT-1-21
12 448	FIT-1-23
12 454	FIT-1-22
12 467	FIT-1-24
12 468	FIT-1-25
12 488	FIT-1-26
12 4D6	FIT-1-28
12 4GA	FIT-3-27
12 4GB	FIT-3-24
12 4GD	FIT-3-29
12 R51	FIT-1-26
12 R71	FIT-1-27
12 TA0	FIT-3-4
12 VA0	FIT-3-3
12 VB0	FIT-3-3
13 004	FIT-1-27
15 020	FIT-2-37
16 020	FIT-2-37
17-001	FIT-9-21
17-104	FIT-9-22
18-033	FIT-9-10
20 A00	FIT-2-34
20 A00	FIT-5-10
20 B00	FIT-2-34
20 B00	FIT-5-10
20 C00	FIT-2-34
20 D00	FIT-2-35
20 D00	FIT-5-10
20 E00	FIT-2-35
20 E00	FIT-5-10
20 F00	FIT-2-35
20 G00	FIT-2-35
20 J00	FIT-2-28
20 K00	FIT-5-11
20 L00	FIT-5-11
20 M00	FIT-5-11
21 020	FIT-5-8
21 040	FIT-5-8
21 051	FIT-5-11
21 060	FIT-5-8
21 225	FIT-5-8
21 247	FIT-5-9
21 257	FIT-5-9
21 A51	FIT-5-9
21 K51	FIT-5-10
3250	FIT-7-4
33 020	FIT-5-5
33 029	FIT-5-5
33 040	FIT-5-5
33 060	FIT-5-5
33 425	FIT-5-5
33 447	FIT-5-6
33 457	FIT-5-6
33 467	FIT-5-6
33 468	FIT-5-7
33 VB0	FIT-5-7
39004100	FIT-5-14
39004160	FIT-5-14
4246	FIT-7-3
48 021	FIT-7-6
48 030	FIT-7-6
4BC	FIT-9-23
4BR	FIT-9-23
4JS	FIT-9-5
4LC	FIT-9-23
4LD	FIT-9-17

Part Number **Page Number**

4LF	FIT-9-19
4LR	FIT-9-18
4MC	FIT-9-23
4PS	FIT-9-5
4SM	FIT-9-5
4SM	FIT-9-7
4TC	FIT-9-23
4TS	FIT-9-7
54 0001	FIT-7-5
5BV	FIT-9-15
5CV	FIT-9-3
5DA	FIT-9-13
5FE	FIT-9-11
5FS	FIT-9-7
5VS	FIT-9-9
70 4331	FIT-4-9
70 4542	FIT-4-5
71 4503	FIT-4-7
94 0509	FIT-1-27
94 0509	FIT-4-9
94 4026	FIT-6-3
94 4138	FIT-4-10
94 4301	FIT-4-11
94 4330	FIT-4-10
94 4439	FIT-4-14
94 4440	FIT-4-15
94 4503	FIT-4-7
94 4504	FIT-4-7
94 4507	FIT-4-7
94 4511	FIT-4-12
94 4514	FIT-4-20
94 4530	FIT-4-6
94 4588	FIT-4-20
94 4590	FIT-4-14
94 4591	FIT-4-12
94 4598	FIT-4-21
94 4601	FIT-4-6
94 4602	FIT-4-8
94 4603	FIT-4-7
94 4607	FIT-4-13
94 4611	FIT-4-6
94 4612	FIT-4-6
94 4639	FIT-4-14
94 4642	FIT-4-8
94 4652	FIT-4-8
94 4666	FIT-4-5
94 4688	FIT-4-21
94 8125	FIT-4-21
94 901	FIT-7-5
94 902	FIT-7-5
94 903	FIT-7-5
94 904	FIT-7-5
94 905	FIT-7-5
94 906	FIT-7-5
94 907	FIT-7-5
94 908	FIT-7-5
94 910	FIT-7-4
94 911	FIT-7-4
94 960	FIT-7-5
94 4027	FIT-6-3
94-4028	FIT-6-3
95 0520	FIT-4-8
95 4111	FIT-4-15
95 4112	FIT-4-17
95 4114	FIT-4-11
95 4331	FIT-4-9
95 4355	FIT-4-6
95 4423	FIT-4-17
95 4470	FIT-4-12
95 4490	FIT-4-6
95 4530	FIT-4-5
95 4563	FIT-4-17
95 4564	FIT-4-12
95 4565	FIT-4-19
95 4570	FIT-4-7
95 4584	FIT-4-18
95 4585	FIT-4-16

Part Number **Page Number**

95 4586	FIT-4-16
95 4587	FIT-4-17
95 4589	FIT-4-18
95 4590	FIT-4-13
95 4593	FIT-4-14
95 4594	FIT-4-20
95 4597	FIT-4-12
95 4600	FIT-4-11
95 4621	FIT-4-15
95 4622	FIT-4-19
95 4653	FIT-4-19
95 4656	FIT-4-19
95 4679	FIT-4-18
95 4761	FIT-4-13
C/636	FIT-3-12
C/637	FIT-3-12
C/639	FIT-3-12
C/650	FIT-3-13
C/677	FIT-3-13
C/836	FIT-3-10
C/837	FIT-3-10
C/839	FIT-3-10
C/840	FIT-3-10
C/855	FIT-3-10
C2020	FIT-1-8
C2023	FIT-1-10
C2040	FIT-1-11
C2060	FIT-1-12
C2082	FIT-1-12/13
C4245	FIT-1-15
C2415	FIT-1-18
C2115	FIT-1-19
C2426	FIT-1-20
C2447	FIT-1-22
C2043	FIT-1-22
C2467	FIT-1-24
C2468	FIT-1-25
C2488	FIT-1-26
C0020	FIT-2-12
C0023	FIT-2-13
C0040	FIT-2-14
C0043	FIT-2-15
C0060	FIT-2-16
C0082	FIT-2-17
C0084	FIT-2-17
C0025	FIT-2-18
C0125	FIT-2-19
C0215	FIT-2-21
C0112	FIT-2-22
C0226	FIT-2-24
C0247	FIT-2-26
C0147	FIT-2-27
C0267	FIT-2-28
C0268	FIT-2-30
C0188	FIT-2-31
C0228	FIT-2-31
C0168	FIT-2-32
C0020	FIT-2-12
C/S	FIT-8-7
M/32009	FIT-7-4
M/3314	FIT-7-4
MA0	FIT-8-4
MB0	FIT-8-4
MBP0	FIT-8-4
MCO	FIT-8-8
ME0	FIT-8-14
MF	FIT-8-5
MFT	FIT-8-5

Part Number **Page Number**

MM0	FIT-8-10
MQ0	FIT-8-9
MS0	FIT-8-6
MU0	FIT-8-6
MV0	FIT-8-13
PA 0	FIT-7-3
PB 0	FIT-7-2
PW	FIT-7-2
S/636	FIT-3-11
S/836	FIT-3-9
T1000	FIT-3-6
T15	FIT-3-8
T20	FIT-8-12
T40	FIT-8-6
T50	FIT-3-15
T51	FIT-3-14
T52	FIT-3-14
T53	FIT-3-14
T55	FIT-3-16
T56	FIT-3-16
T60	FIT-3-18
T65	FIT-3-33
T70	FIT-3-31
WT 4	FIT-5-13



Warning

These products are intended for use in industrial compressed air systems only. Do not use these products where pressures and temperatures can exceed those listed under **Specifications**.

Before using these products with fluids other than those specified, for nonindustrial applications, life-support systems, or other applications not within published specifications, consult NORGREN.

Through misuse, age, or malfunction, components used in fluid power systems can fail in various modes. The system designer is warned to consider the failure modes of all component parts used in fluid power systems and to provide adequate safeguards to prevent personal injury or damage to equipment in the event of such failure modes. **System designers must provide a warning to end users in the system instructional manual if protection against a failure mode cannot be adequately provided.**

System designers and end users are cautioned to review specific warnings found in instruction sheets packed and shipped with these products. System designers should also provide for all OSHA requirements including Title 29 CFR 1910.147 Lockout/Tagout.

It should be recognized that warnings are valid for any product, regardless of manufacturer, and are not restricted to products manufactured by NORGREN. NORGREN's reputation for product quality and performance is well established. We feel we have the additional obligation to provide information or warnings to customers to assist them in applying our products in a reasonable and safe manner.

Warranty

Items sold by NORGREN are warranted to be free from defects in materials and workmanship for a period of two year from the date of manufacture, provided said items are used according to NORGREN's recommended usages. NORGREN's liability is limited to the repair of, refund of purchase price paid for, or replacement in kind of, at NORGREN's sole option, any items proved defective, provided the allegedly defective items are returned to NORGREN prepaid. The warranties expressed above are in lieu of and exclusive of all other warranties.

There are no other warranties, expressed or implied, except as stated herein. There are no implied warranties of merchantability or fitness for a particular purpose, which are specifically disclaimed. NORGREN's liability for breach of warranty as herein stated is the exclusive remedy, and in no event shall NORGREN be liable or responsible for incidental or consequential damages, even if the possibility of such incidental or consequential damages has been made known to NORGREN.

NORGREN reserves the right to discontinue manufacture of any product or change product materials, design, or specifications.



www.norgren.com is your complete source for the latest Norgren product information, technical tips, and other valuable pneumatic information.

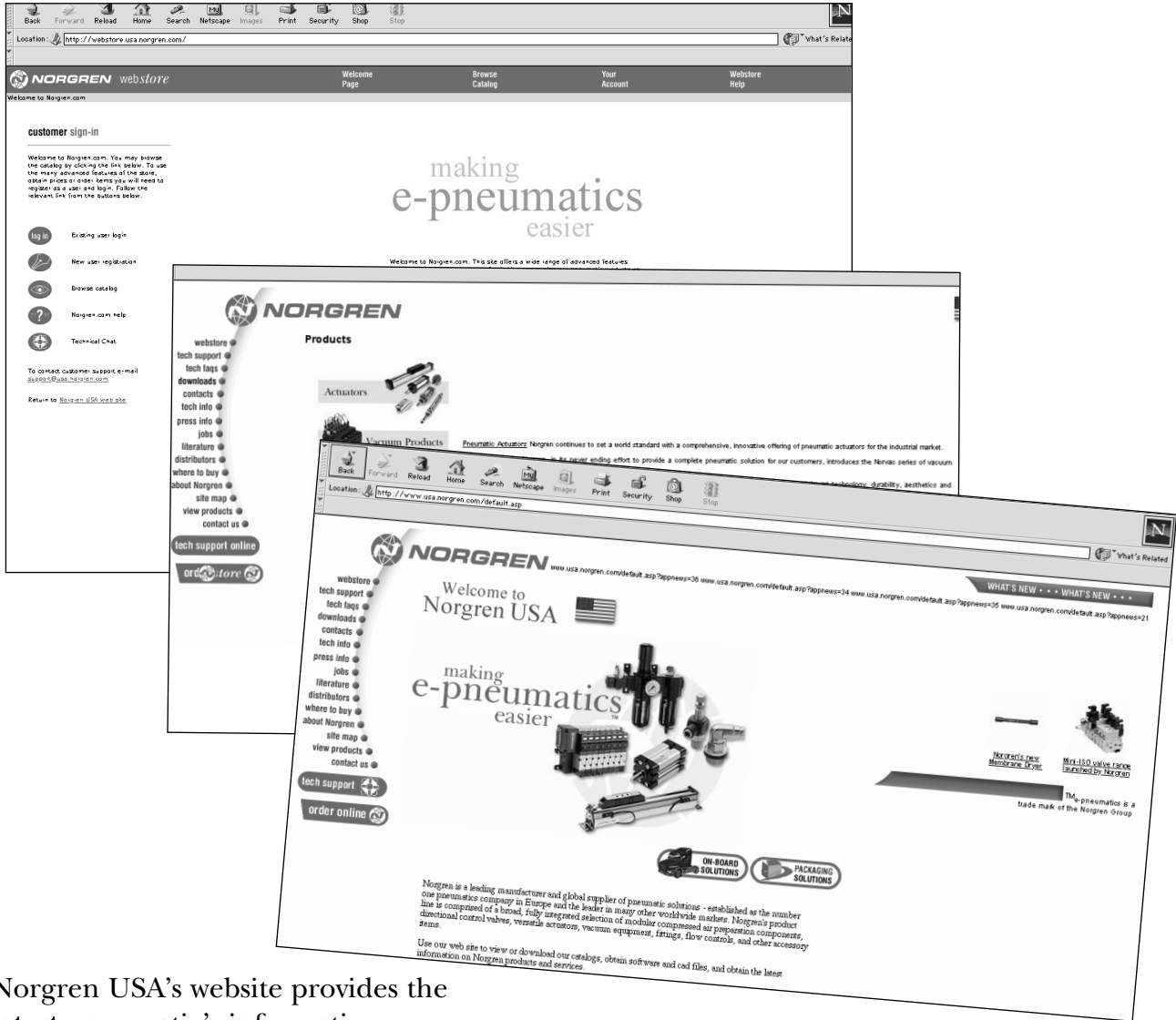

Norgren USA's website provides the latest pneumatic's information available from Norgren USA. It is the source for additional pneumatic product catalogs, CAD files, circuit design software, distributor locations, customer service and application engineering contacts.

To access our website, set your web browser to: www.norgren.com



5400 South Delaware Street
Littleton, Colorado 80120-1663
Phone: 303-794-2611 Fax: 303-795-9487
www.norgren.com
e-mail: inquiry@usa.norgren.com



Norgren's CD Catalog (NCDC) is the latest in product information and specifications. This CD contains complete product information, pricing, CAD files, pneumatic solutions, the latest applications news, and a customer survey. Contact your local distributor and order part number NCDC.

NCDC

Norgren CD Catalog



**75TH
ANNIVERSARY
1926 ★ 2001**

Norgren's CD Catalog is a Complete Source for Norgren Pneumatic Products, Solutions, Pricing, CAD, and a host of additional information.

 **NORGREN**



All Product Catalog APC-102 is your complete guide to Norgren Inline Valves, and Subbase Valves and Accessories. Valves range from Cv of 0.3 to 49.5. Call your local distributor and order Part Number APC-102.

APC-102

Norgren Pneumatic Valve Products



75TH ANNIVERSARY
1926 ★ 2001

The Complete Guide to Norgren Inline Valves, Subbase Valves and Accessories Ranging from Cv of 0.3 to 49.5.

 **NORGREN**



Norgren offers one of the most comprehensive pneumatic actuator lines in the industry. Contact your distributor to order All Product Catalog APC-103 to get all the information.

APC-103

Norgren Pneumatic Actuator Products and Accessories

The Complete Selection of
Norgren Pneumatic Actuators
and Accessories

 **NORGREN**



APC-104 showcases Norgren's extensive line of air preparation products for the pneumatics industry. You can contact your distributor and order APC-104.

APC-104

Norgren Air Preparation Products and Accessories



A Complete Selection of Norgren Products and Accessories for Effective Compressed Air Preparation

