

DIN RAIL MOUNTED TYPE INDICATING CONTROLLER

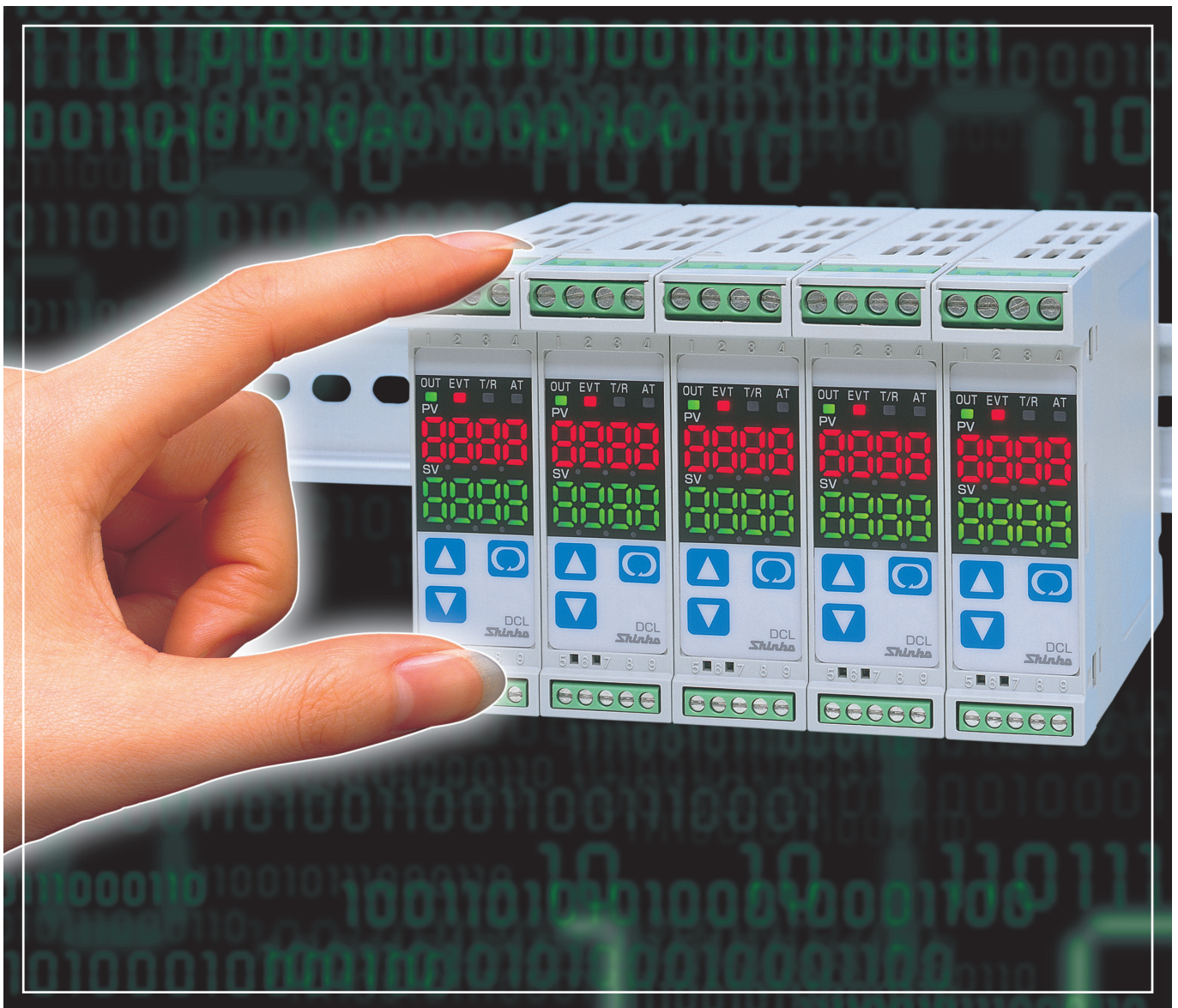

Indicating Controller

DCL-33A SERIES



A compact, versatile controller and converter rolled into one!

Shinko

Features

Compact and expandable controller and converter in one

Compact

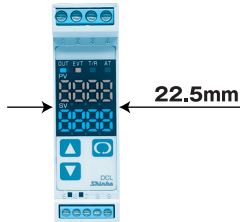

The DCL-33A can be installed in narrow spaces. (Width: 22.5mm, Height: 75mm, Depth: 100mm)

Conforms to Modbus protocol

Shinko protocol and Modbus protocol are provided as a serial communication (C5) protocol (For Modbus protocol, RTU mode and ASCII mode are available).

Therefore, the DCL-33A can be connected to Modbus compatible instruments without using a communication converter.

Can be used as a set value digital receiver

By using Shinko programmable controller (with SVTC option) as a program setter in combination with DCL-33A (with C5 option), the DCL-33A can also be used as a programmable controller for multiple positions. (A maximum of 31 units of DCL-33A can be connected.)

Multi-input

Total 18 input types [thermocouple (10 types) RTD (2 types), DC current (2 types) and DC voltage (4 types)] allow you to deal with various processes.

Possible to expand control points

From one to max. 31 spots of measurement control can be carried out through serial communication (RS-485).

It is very easy to connect DCL-33A units by using the exclusive communication cable (CDD) between them.

(When connecting more than 31 units of DCL-33A, please consult us)

Easy mounting and removal

Hook the upper part of the DCL-33A to the DIN rail and fit the lower part of it to the DIN rail.

Fixed DCL-33A is resistant to vibration, and easy to maintain.

To remove the DCL-33A from the DIN rail, release the hook at the lower part of the DCL-33A by sliding it downward with a flat bladed screwdriver.

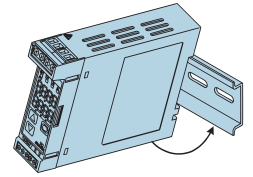

Safety standard

UL/C-UL and CE marking

Specifications

Model name

D C L - 3 3 A - □ / □ M, □, □ □ □		Series name: DCL-33A (W22.5 x H75 x D100mm)
Control output (OUT)	R	Relay contact: 1a
	S	Non-contact voltage (for SSR drive): 12 [±] 0 V DC
	A	DC current: 4 to 20mA DC
Input	M	Multi-input
Supply voltage	1	100 to 240V AC (*1) 24V AC/DC
Options	W (5A)	Rated current: 5A
	W (10A)	Rated current: 10A Heater burnout alarm
	W (20A)	Rated current: 20A (*2)
	W (50A)	Rated current: 50A
	C5	Serial communication (EIA RS-485)

Please designate the specification from the □, □ □ □ columns.

When adding an option, enter it punctuated by a comma.

(*1): For the power supply, 100 to 240V AC is standard. However, when ordering 24V AC/DC, enter "1" after the input.

(*2): For DC current output type, the W option cannot be applied.

Name and functions of the sections

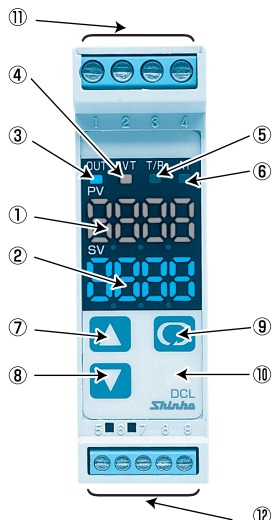

- ① PV display: Indicates the input value (PV). Indicates characters during setup.
- ② SV display: Indicates the SV. Indicates the set value of each setting item during setup.
- ③ OUT indicator: Lights when control output (OUT) is ON. (For DC current output type, this flashes in 0.25 second cycles corresponding to the output manipulated variable.)
- ④ EVT indicator: Lights when Alarm, Loop break alarm or Heater burnout alarm (option) is ON.
- ⑤ T/R indicator: Flashes when responding to the command from the host computer during serial communication.
- ⑥ AT indicator: Flashes while PID auto-tuning or PD auto-reset is being performed.
- ⑦ Increase key: Sets or selects each setting item value (Increases the numeric value).
- ⑧ Decrease key: Sets or selects each setting item value (Decreases the numeric value).
- ⑨ Mode key: Changes the setting mode or registers the set value.
- ⑩ Sub-mode key: Brings up setting item in combination with a Increase or Decrease key.
- ⑪ Power terminals, control output (OUT) terminals
- ⑫ Input terminals, EVT output terminals

Rated scale

Input types		Scale	
Thermo-couple	K	-200 to 1370 °C	-320 to 2500 °F
		-199.9 to 400.0 °C	-199.9 to 750.0 °F
	J	-200 to 1000 °C	-320 to 1800 °F
		0 to 1760 °C	0 to 3200 °F
	S	0 to 1760 °C	0 to 3200 °F
	B	0 to 1820 °C	0 to 3300 °F
	E	-200 to 800 °C	-320 to 1500 °F
	T	-199.9 to 400.0 °C	-199.9 to 750.0 °F
	N	-200 to 1300 °C	-320 to 2300 °F
	PL-II	0 to 1390 °C	0 to 2500 °F
C (W/Re5-26)	0 to 2315 °C	0 to 4200 °F	
RTD	Pt100	-200 to 850 °C	-300 to 1500 °F
		-199.9 to 850.0 °C	-199.9 to 999.9 °F
	JPt100	-200 to 500 °C	-300 to 900 °F
DC current	4 to 20mA		-1999 to 9999
	0 to 20mA		-199.9 to 999.9
DC voltage	0 to 1V		-19.99 to 99.99
	0 to 5V		-1.999 to 9.999
	1 to 5V		-1.999 to 9.999
	0 to 10V		

• For DC current and DC voltage inputs, scaling and decimal point place change are possible.

• For DC current input, 50 Ω shunt resistor (sold separately) has to be externally installed.

Standard specifications

Display	PV: Red 4-digit, character size; 7.4 x 4.0mm (H x W) SV: Green 4-digit, character size; 7.4 x 4.0mm (H x W)
Input	<p>Thermocouple ---- K, J, R, S, B, E, T, N, PL-II, C(W/Re5-26) External resistance: 100Ω or less (For B input: 40Ω or less)</p> <p>RTD ----- Pt100, JPt100 3-wire system (Allowable input lead wire resistance, 10Ω or less per wire)</p> <p>DC current ----- 0 to 20mA DC, 4 to 20mA DC 50Ω shunt resistor (50Ω shunt resistor must be connected between input terminals) Allowable input current: 100mA or less</p> <p>DC voltage ----- 0 to 1V DC Input impedance: 1MΩ or more, Allowable input voltage: 5V or less, Allowable signal source resistance: 2kΩ or less</p> <p>0 to 5V DC, 1 to 5V DC, 0 to 10V DC Input impedance: 100kΩ or more, Allowable input voltage: 15V or less Allowable signal source resistance: 100Ω or less</p>
Accuracy (Setting, Indication)	<p>Thermocouple ----- Within ±0.2% of input span ±1digit, or within ±2°C (4°F), whichever is greater However, for R or S input, 0 to 200°C (0 to 400°F): Within ±6°C (12°F) B input, 0 to 300°C (0 to 600°F): Accuracy is not guaranteed.</p> <p>RTD ----- Within ±0.1% of input span ±1digit, or within ±1°C (2°F), whichever is greater</p> <p>DC current, voltage ---- Within ±0.2% of input span ±1digit</p>
Input sampling period	0.25 seconds
Control output (OUT)	<p>Must be specified</p> <ul style="list-style-type: none"> • Relay contact ----- 1a 3A 250V AC(resistive load), 1A 250V AC (inductive load $\cos \phi = 0.4$), Electric life: 100,000 times • Non-contact voltage -- 12⁺V DC Max. 40mA DC (short circuit protected) • DC current----- 4 to 20mA DC Load resistance: Max. 550Ω Output accuracy: Within ±0.3% of Output span (Within ±0.048mA) Resolution: 12000
Control action	<p>The following action can be selected by keypad operation [Default: PID] PID (with AT), PI action, PD action (with manual reset), P action (with manual reset), ON/OFF action</p> <p>Proportional band (P) : 0.0 to 110.0% (ON/OFF action when set to 0.0) [Default: 2.5%] Integral time (I) : 0 to 1000sec (Off when set to 0) [Default: 200sec] Derivative time (D) : 0 to 300sec (Off when set to 0) [Default: 50sec] Proportional cycle : 1 to 120sec (Not available for DC current output type) [Default: 30sec for relay contact, 3sec for non-contact voltage] ARW : 0 to 100% [Default: 50%] Manual reset : ±Proportional band converted value [Default: 0.0] Hysteresis : For thermocouple and RTD, 0.1 to 100.0°C (°F) [Default: 1.0°C] For DC input, 1 to 1000 (The placement of the decimal point follows the selection.) Output limit : 0 to 100% (for DC current output type, —5 to 105%)</p>
Event output (EVT)	<p>Alarm action types and status Energized/Deenergized can be selected by keypad operation.</p> <ul style="list-style-type: none"> • No alarm action • High limit alarm (Deviation setting) Setting range: —Scaling span to scaling span • Low limit alarm (Deviation setting) Setting range: —Scaling span to scaling span • High/Low limits alarm (Deviation setting) Setting range: 0 to scaling span • High/Low limit range alarm (Deviation setting) Setting range: 0 to scaling span • Process high alarm Setting range: Scaling low limit value to scaling high limit value • Process low alarm Setting range: Scaling low limit value to scaling high limit value • High limit alarm with standby (Deviation setting) Setting range: —Scaling span to scaling span • Low limit alarm with standby (Deviation setting) Setting range: —Scaling span to scaling span • High/Low limits alarm w/standby (Deviation setting) Setting range: 0 to scaling span <p>Negative minimum value: —199.9, —1999 Positive maximum value: 999.9, 9999 Setting accuracy -- The same as the indicating accuracy Action ----- ON/OFF action Hysteresis ----- Thermocouple, RTD: 0.1 to 100.0°C (°F) DC current, voltage input: 1 to 1000 (The placement of the decimal point follows the selection.) Output ----- Open collector Control capacity: 24V DC 0.1A (Max.)</p>
Loop break alarm	<p>Detects heater burnout, sensor burnout and actuator trouble.</p> <p>Loop break alarm time ---- 0 to 200 minutes</p> <p>Loop break alarm span ---- Thermocouple and RTD input: 0 to 150°C (°F) or 0.0 to 150.0°C (°F) DC current, voltage input: 0 to 1500</p> <p>Output ----- Open collector Control capacity: 24V DC 0.1A (Max.)</p>
Heater burnout alarm (option)	<p>Watches heater current with current transformer (CT) and detects Heater burnout. Heater rated current must be designated from 5A, 10A, 20A, 50A.</p> <p>Setting range ----- Rated current 5A: 0.0 to 5.0A, Rated current 10A: 0.0 to 10.0A Rated current 20A: 0.0 to 20.0A, Rated current 50A: 0.0 to 50.0A</p> <p>Setting accuracy ---- Within ±5% of heater rated current</p> <p>Output ----- Open collector Control capacity: 24V DC 0.1A (Max.) Output self holding -- Not available Accessories ----- CT [CTL-6-S (for 5A,10A, 20A), or CTL-12-S36-10L1U (for 50A)] (1piece), Wire harness (3m)</p>
Supply voltage	<p>Must be specified.</p> <p>100 to 240V AC 50/60Hz, 24V AC/DC 50/60Hz</p> <p>For the supply voltage, 100 to 240V AC is standard. When ordering 24V AC/DC, enter "1" after the input code. Allowable voltage fluctuation range: 85 to 264V AC, 20 to 28V AC/DC</p>
Power consumption	Approx. 6VA
Insulation resistance	<p>For non-contact voltage output type (SSR drive) or DC current output type, insulation test must not be performed because output terminals and communication terminals are not insulated from one another. Other combination except above: 10MΩ or more, at 500V DC</p>
Dielectric strength	1.5kV AC for 1 minute between input terminals and power terminals, between output terminals and power terminals
Environment	Ambient temperature: 0 to 50°C Ambient humidity: 35 to 85%RH (Non-condensing)
Safety standard	UL: Power input rating 100 - 240V AC, 24V AC/DC File No. E159038
Material • Color	Material: Flame-resistant resin Color: Light gray
External dimension	22.5 x 75 x 100mm (W x H x D)
Mounting	DIN rail
Setting	Sheet key input
Weight	Approx. 120g
Attached functions	Sensor correction, Set value lock, Power failure countermeasure, Self-diagnosis, Automatic cold junction temperature compensation (thermocouple only), Sensor burnout alarm, Input abnormality indication

Options

Heater burnout alarm (W) Refer to Heater burnout alarm (option) of Event output.

Serial communication (C5) Reading and setting of the various set values or various setting status changes of the DCL-33A can be operated from the external computer.
The SV of the programmable controller (with SVTC option) can be transmitted to the DCL-33A (with C5 option) digitally in combination with programmable controller(with SVTC option) and DCL-33A (with C5 option).

Communication interface --- EIA RS-485

Communication method ----- Half-duplex communication start-stop synchronization

Communication speed ----- 2400/4800/9600/19200bps (Selectable by keypad operation)

Parity ----- Even/Odd/No parity (Selectable by keypad operation) (only for Modbus protocol)

Stop bit ----- 1 or 2 (Selectable by keypad operation) (only for Modbus protocol)

Communication protocol ---- Shinko protocol/Modbus protocol (Selectable by keypad operation)

Data format

Protocol	Shinko	Modbus RTU	Modbus ASCII
Start bit	1	1	1
Data bit	7	8	7
Parity	Even	Selected value	Selected value
Stop bit	1	Selected value	Selected value

Number of connectable units ----- A maximum of 31 units per host computer

Communication error detection --- Double detection by the parity and checksum

External dimensions (Scale: mm)

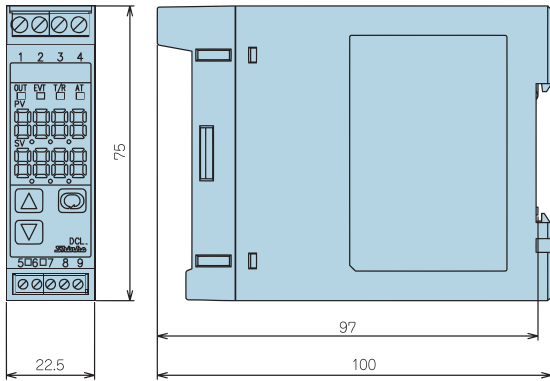

CT dimensions (Scale: mm)

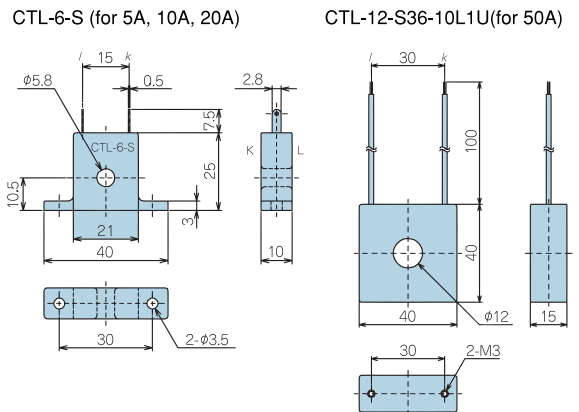

Terminal arrangement

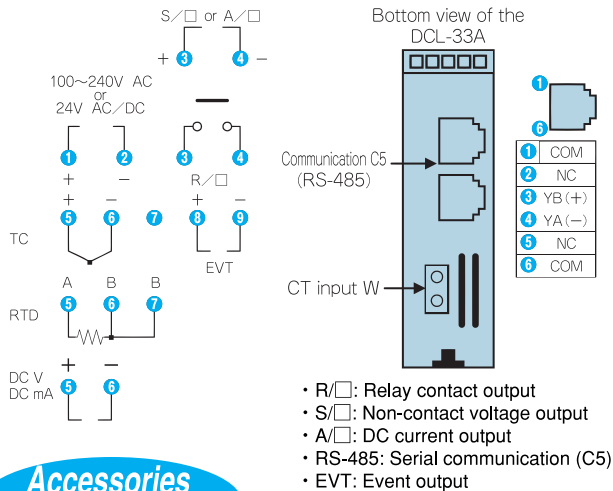

Ferrules and fastening torque

Terminal number	Terminal screw	Ferrules with insulation sleeve	Conductor cross sections	Tightening torque	Crimping pliers
1 to 4	M2.6	AI 0.25-8 YE	0.2 to 0.25mm ²	0.5 to 0.6N·m	CRIMPFOX ZA 3 CRIMPFOX UD 6
		AI 0.34-8 TQ	0.25 to 0.34mm ²		
		AI 0.5-8 WH	0.34 to 0.5mm ²		
		AI 0.75-8 GY	0.5 to 0.75mm ²		
		AI 1.0-8 RD	0.75 to 1.0mm ²		
5 to 9	M2.0	AI 1.5-8 BK	1.0 to 1.5mm ²	0.22 to 0.25N·m	
		AI 0.25-8 YE	0.2 to 0.25mm ²		
		AI 0.34-8 TQ	0.25 to 0.34mm ²		
		AI 0.5-8 WH	0.34 to 0.5mm ²		

When using ferrules, use the above ferrules and crimping pliers made by Phoenix Contact GMBH & CO.

Accessories
sold separately

Communication cable

Model	Description
CDD	Communication cable to connect the DCL-33A units Cable length: Approx. 60mm
CDH	Communication cable to connect the DCL-33A and touch panel unit Cable length: Approx. 0.5m (standard) (Can be extended by 0.5m each time.)
CDM	Communication cable to connect the DCL-33A and OMR-100, or connect the DCL-33A and touch panel unit or programmable controller Cable length: Approx. 3m (standard) (Can be extended by 1m each time.)
CPP	Communication cable to connect the DCL-33A and SIF-400 Cable length: Approx. 0.5m (standard) (Can be extended by 0.5m each time.)

External dimensions

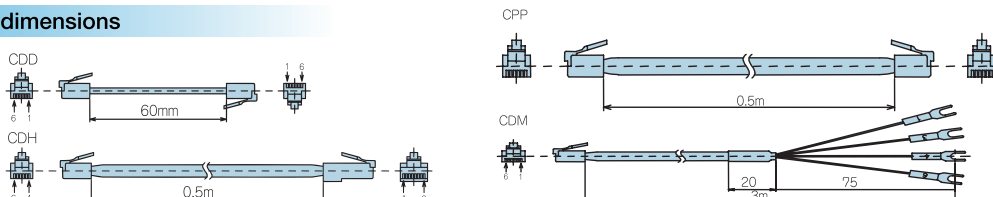

Console unit for DCL-33A OMR-100

One OMR-100 installed on the control panel can perform settings for up to 10 DCL-33A units with the communication function in the control panel and monitor their control.

Standard specifications

Display	PV display: Red LED 4 digits, character size 8 x 4mm (H x W) SV display: Green LED 4 digits, character size 8 x 4mm (H x W) CH display: Yellow LED 1 digit, character size 8 x 4mm (H x W)
Indicator	ALM: Red LED lights when the Alarm is activated. OUT: Green LED lights when the control output is ON. ERR: Lights when serial communication errors occur. SB: Red LED lights when sensor is burnt out. INITIAL: Yellow LED lights while set values are being read. TX/RX: Yellow LED lights during serial communication TX output. AT: Yellow LED lights during auto-tuning.
Alarm output	The output is turned on when the alarm is activated. (Common to all channels) Output: Relay contact, 1a, Control capacity, 3A 250V AC(resistive load), 1A 250V AC(Inductive load cos φ=0.4)
Serial communication	Communication line : EIA RS-485 Communication method : Half-duplex communication start-stop synchronization Communication speed : 19200bps Data format : Start bit (1), Data bit (7), Parity(Even), Stop bit (1) Transmitted contents : SV, Alarm value, OUT proportional cycle, OUT proportional band, Integral time, Derivative time, ARW, Manual reset value, AT, Set value lock Received contents : Transmitted contents above, Control input value, Status flag (Output status, Overscale, Underscale, During AT) Communication error output: Turns ON when communication errors occur. Output : Relay contact, 1a Control capacity, 3A 250V AC (resistive load) 1A 250V AC (inductive load cos φ=0.4)
Supply voltage	Must be specified. 100 to 240V AC 50/60Hz, 24V AC/DC 50/60Hz (For supply voltage, 100 to 240V AC is standard. However, when ordering 24V AC/DC, enter "1" after model name OMR-100.) Allowable fluctuation range: 85 to 264V AC, 20 to 28V AC/DC
Power consumption	Approx. 5VA
Insulation resistance	10MΩ or more, at 500V DC
Dielectric strength	1.5kV AC for 1minute between power terminals and ground terminal, between communication terminals and ground terminal:
Environment	Ambient temperature: 0 to 50°C, Ambient humidity: 35 to 85%RH (Non-condensing)
Weight	Approx. 320g
External dimension	48 x 96 x 100mm(W x H x D)
Attached functions	Self diagnosis, Warm-up indication, Error indication when changing set value, Indication when communication errors occur
Options	Mounting bracket [BL]: Mountable panel thickness, 1 to 8mm Dust-proof/Drip-proof [IP]: IP54 Terminal cover [TC]: Electric shock protection terminal cover

External dimensions (Scale: mm)

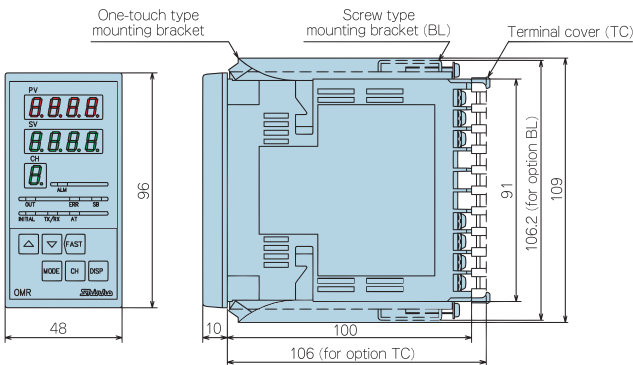

Panel cutout (Scale: mm)

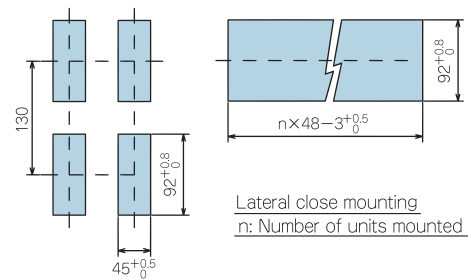

Terminal arrangement

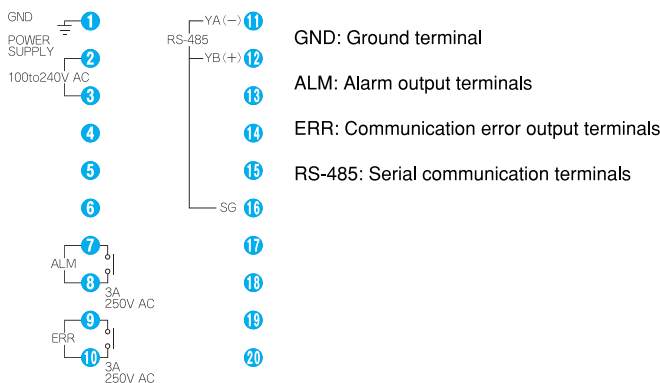

Wiring

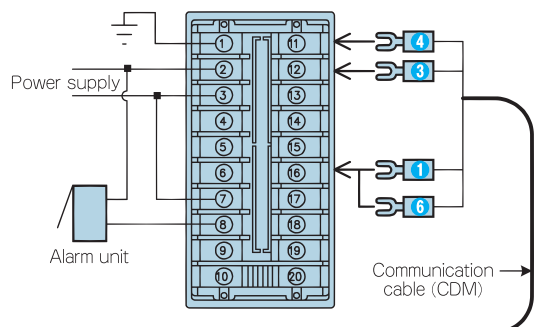

Solderless terminal

Use a solderless terminal with an insulation sleeve in which the M3 screw fits as shown below. The tightening torque should be 0.63N·m.

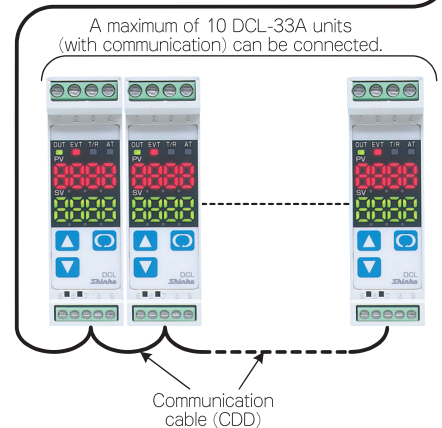
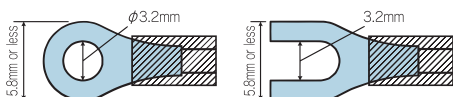

When a PC monitors multiple DCL-33A units

By connecting to the PC, up to 40 points of temperature control can be monitored using a communication converter.
 (If PC's communication specification is RS-485, it is not necessary to use a communication converter.)
 As a communication converter, Shinko IF-400 is provided.
 SWM-JC001M is also available as monitoring software.

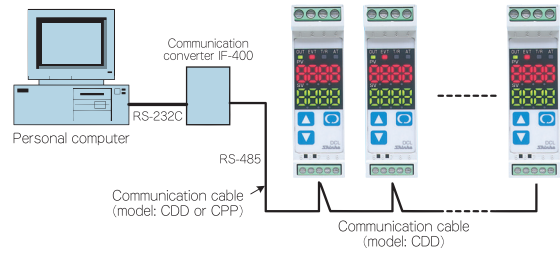

When a touch panel unit monitors plural DCL-33A units

A maximum of 31 points of temperature control and monitoring can be carried out by connecting DCL-33A to the touch panel unit.
 The following touch panel units are available.
 Digital Electronics Corp.: GLC series, GP series
 Hakko Electronics CO., LTD.: V7 series, V6 series
 (For the communication cable, use Shinko's exclusive cable.)

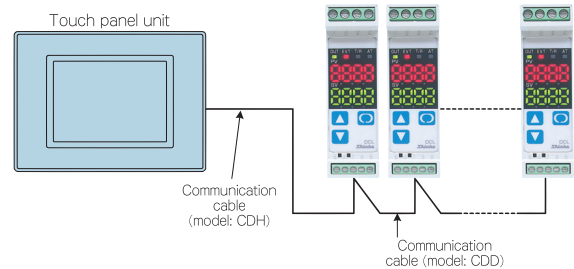

When using DCL-33A units as a programmable controller

By using Shinko programmable controller PCD-33A or PC-935 (with SVTC option) as a program setter in combination with DCL-33A (with C5 option), DCL-33A can also be used as a programmable controller for a maximum of 31 positions.

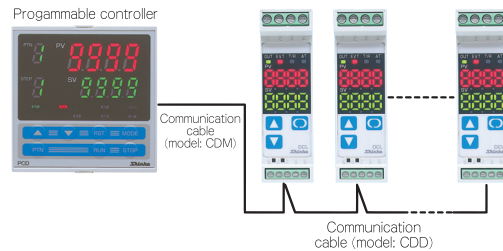

When using max. 50 DCL-33A units with the PLC

By connecting to the PLC via PLC interface unit SIF-400, a maximum of 50 DCL-33A units can be connected.
 Please make inquiries concerning the PLC compatible with SIF-400 to us or our agency.

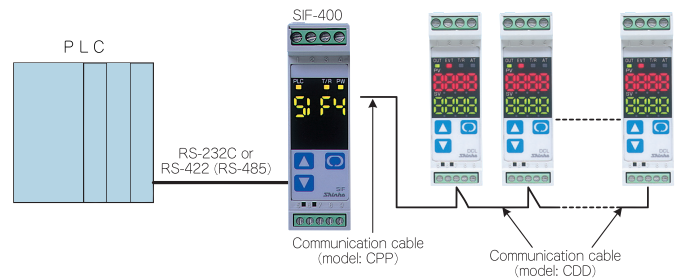

SAFETY PRECAUTIONS

- To ensure safe and correct use, thoroughly read and understand the manual before using this instrument.
- This instrument is intended to be used for industrial machinery, machine tools and measuring equipment. Verify correct usage after consulting purpose of use with our agency or main office.
(Never use this instrument for medical purposes with which human lives are involved.)
- External protection devices such as protection equipment against excessive temperature rise, etc. must be installed, as malfunction of this product could result in serious damage to the system or injury to personnel. Also proper periodic maintenance is required.
- This instrument must be used under the conditions and environment described in the manual. Shinko Technos Co., Ltd. does not accept liability for any injury, loss of life or damage occurring due to the instrument being used under conditions not otherwise stated in the manual.

Caution with respect to Export Trade Control Ordinance

To avoid this instrument from being used as a component in, or as being utilized in the manufacture of weapons of mass destruction (i.e. military applications, military equipment, etc.), please investigate the end users and the final use of this instrument. In the case of resale, ensure that this instrument is not illegally exported.



· This catalog is as of October 2007 and its contents are subject to change without notice.
 · If you have any inquiries, please consult us or our agency.

SHINKO TECHNOS CO., LTD. OVERSEAS DIVISION

Reg. Office : 2-5-1, Senbahigashi, Minoo, Osaka, 562-0035, Japan
 Tel : 81 - 72 - 727 - 6100
 Fax : 81 - 72 - 727 - 7006
 URL : <http://www.shinko-technos.co.jp>
 E-mail : overseas@shinko-technos.co.jp