

Series 150E

Conductance Probe Type

Low Water Cut-Offs & Pump Controllers



The Series 150E provides continuous protection against a low water condition and satisfies pump control needs for commercial and industrial steam boilers.

The 150E compensates for rapidly changing boiler water levels. It has adjustable burner and pump settings and powerful 1 HP relays.

Typical Applications

- Primary and secondary low water fuel cut-off protection and pump control for commercial and industrial steam boilers
- Motorized valve controller, low water cut-off, high water cut-off, and alarm actuator for boilers, vessels and tanks

Features

- Set points and differentials remain constant throughout pressure range
- Adjustable 60-second burner-off time delays
- Adjustable 3/4" or 1-3/16" pump differentials
- 1 HP burner and pump relays

Benefits

- Prevents rapid burner and pump cycling
- Constant operation throughout pressure range
- Electrical starters not required for motors up to 1 HP

Specifications

NEMA 1 enclosure

Maximum operating pressure 150psi (10.5 kg/cm²)

Maximum ambient temperature 135°F (57°C)

Maximum operating temperature 366°F (185°C) (at probes)



150E



157E



150E-HD

Electrical Rating and Switch Ratings

Supply Voltage	Probe Voltage	Full load (Amps) NO (NC), (VAC)	Locked Rotor (Amps) NO (NC), (VAC)	Pilot Duty (VA) NO (NC), (VAC)	Motor (HP) NO (NC), (VAC)
120 VAC	5 VAC	16 (5.8), 120	96 (34.8), 120	470 (290), 120	1 (1/4), 120
50/60Hz	Maximum	8 (4.9), 240	48 (17.4), 240	470(360), 240	2 (1/2), 240

Ordering Information

Part Number	Name	Description	Weight lbs. (kg.)
171600	150E	Combination low water cut-off/pump controller	22.9 (10.4)
171610	150E-M	150E w/manual reset	22.9 (10.4)
171620	157E	150E w/water column	36.9 (16.7)
171630	157E-M	157E w/manual reset	36.9 (16.7)
Replacement Parts			
171640	150E-HD	Head Mechanism for 150E or 157	8.7 (3.9)
171650	150E-M-HD	Head Mechanism for 150E-M or 157E-M	8.7 (3.9)
310490	150E-CU	Control Unit for 150E or 157E	2.7 (1.2)
310491	150E-M-CU	Control Unit for 150E-M or 157E-M	2.7 (1.2)
310492	150E-PF	Probe and flange assembly for all 150E's & 157E's	6.0 (2.7)

Electrical Wiring

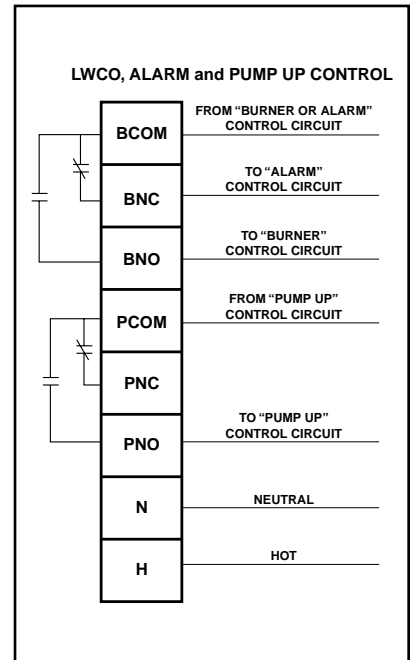

Model 150E Dimensions, in. (mm)

A	B	C	D	E
6 11/16 (169)	11 5/16 (286)	6 (152)	14 3/16 (359)	3 5/16 (84)

F	G	H	J NPT
10 7/8 (275)	4 1/8 (105)	3 7/16 (87)	1 (25)

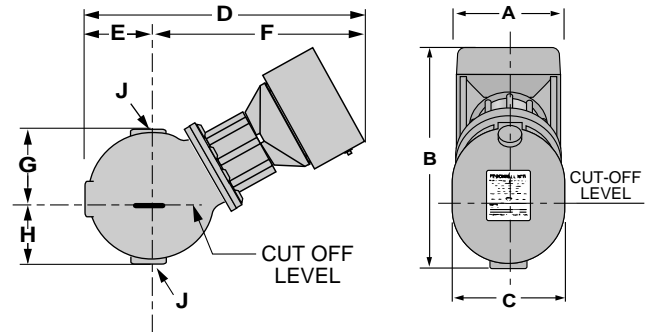

Model 157E Dimensions, in. (mm)

A NPT	B NPT	C	D	E
1 (25)	1/2 (15)	14 5/16 (362)	2 5/16 (59)	4 15/16 (125)

F	G	H	J	K NPT	L
12 5/8 (319)	16 (406)	11 1/2 (292)	3 1/2 (89)	3/4 (20)	5 7/8 (149)

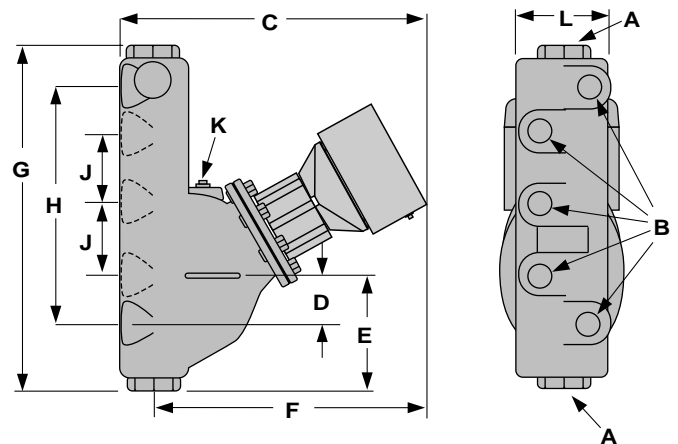

McDonnell & Miller



3500 N. Spaulding Avenue
Chicago, Illinois 60618
tel: 773 267-1600
fax: 773 267-0991
www.mcdonnellmiller.com

©2000 ITT Industries Inc.
Printed in U.S.A. 9-00