



## THE G12 LINE OF AS-INTERFACE MODULES MAKING AS-INTERFACE EVEN FASTER

**S**everal very significant advantages of the new G12 line give Pepperl+Fuchs a distinct advantage over the competition. This technology report points out why the G12 modules from P+F are easily the best AS-Interface modules available today.

Written by:  
Helge Hornis, Ph.D.  
Manager, Intelligent Systems

# Making AS-Interface even faster with the new G12 modules

## The most advanced AS-Interface module on the market is now even faster!

The most important reasons for the success of AS-Interface are its simplicity, flexibility and speed of installation. With the new G12 line of AS-Interface modules, Pepperl+Fuchs sets a speed record in terms of installation and trouble shooting.

Several very significant advantages of the new G12 line (over its successful predecessor, the G2 line) are immediately obvious, giving Pepperl+Fuchs a distinct advantage over the competition. This technology report points out why the G12 modules from P+F are easily the best AS-Interface modules available today.

Immediately obvious . . .

Tool-free installation and SPEEDCON M12 connections are two obvious advances. The stainless steel installation bar pulls the module safely onto the stainless steel base...in record time. Once the installation bar has been closed, a "click" tells the user that the module has been installed properly and securely. SPEEDCON M12 is the only 100% backward and forward 1/2-turn quick disconnect solution available. With SPEEDCON, connecting an input or output to the module takes only a second or two.

When installation time is critical there simply is no faster way!



Stainless steel installation bar and SPEEDCON give G12 AS-Interface modules exceptional installation speed.

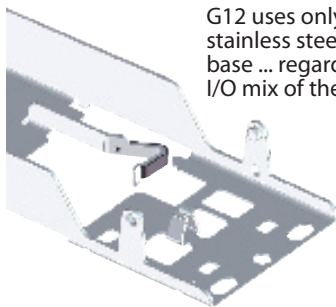

G12 uses only one type of stainless steel mounting base ... regardless of the I/O mix of the module.

Keep it simple with just one stainless steel mounting base. G12 comes in a number of I/O mixes and two distinct housing sizes. To further simplify the ease of use, both housing sizes use the same rugged stainless steel mounting base. Advantage: Changing the I/O count is as simple as replacing one module top with another, no remounting the base and AS-Interface cable. This is just another example of how P+F helps customers get systems designed, built, and out the door quickly.

## Fast diagnostics saves money

AS-Interface has always been strong on diagnostics. With G12, we've raised the bar. In addition to well-known diagnostic features introduced over the last few years, G12 now offers output-specific overload indication right on the module. Under normal operating conditions the multicolor LEDs display the state of the output. But what about short-circuited or overloaded outputs? At the PLC, these states are easily detected via the peripheral fault bit. This allows maintenance personnel to quickly determine which module has a problem. With output-specific indication this process just got a lot simpler and faster. On G12, the overloaded output is directly indicated via a red LED. This takes the guessing out of troubleshooting! Faster resolution results in higher machine up-time and more satisfied customers.

Output-specific diagnostics provide even faster diagnostics and trouble shooting.



# Making AS-Interface even faster with the new G12 modules

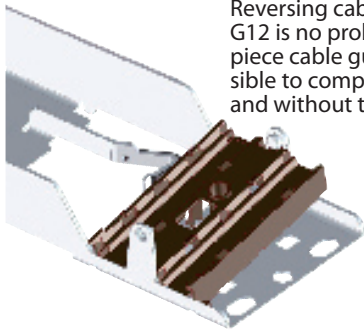

Reversing cable direction through G12 is no problem. The single-piece cable guide makes it possible to complete the task quickly and without tools.

“Let me change the AS-Interface cable orientation ... quickly!”

Yes, it does happen occasionally. The top-bottom orientation of the AS-Interface flat cable needs to be reversed. No problem...and done in seconds.

1. Remove cable guide from stainless steel mounting base
2. Flip it over
3. Push it back into position
4. Ready to go!

GOLD: the right choice for the future . . .

The right choice of piercing contacts is extremely important for long-term, AS-Interface performance. And at P+F, only GOLD is good enough. Our machined, gold-plated contacts offer corrosion resistance that is superior to cheap, stamped (flat) contacts plated with non-precious metals. The round pins do not damage the individual cable strands of the AS-Interface cable and result in perfect lateral orientation.

Every G12 uses gold-plated, machined piercing contacts. When it comes to contact reliability, failure is not an option.

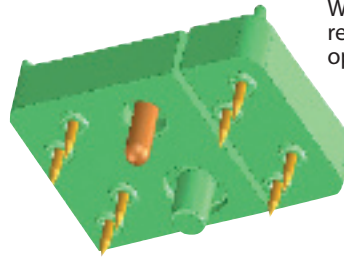

With the integrated DIN clip our stainless steel mounting base customers do not have to choose ahead of time how G12 is mounted. Less to consider means faster planning, ordering, and installation.

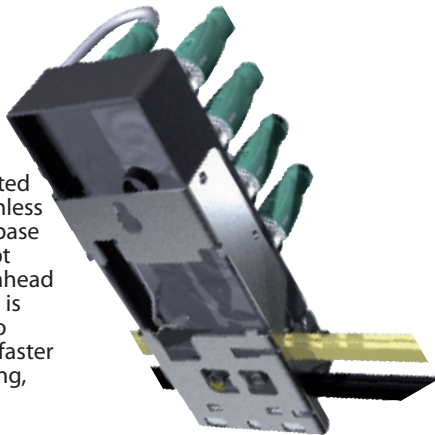

DIN mount ... integrated

Many customers use DIN rail even outside of enclosures and junction boxes. G12 addresses this trend with its integrated DIN clip. This feature speeds up planning, ordering, and

No-tools means just that: No-tools

Compared to other so-called “no-tool” AS-Interface modules on the market, G12 takes this claim very literally. And removing the addressing jack cover is no exception!



# Making AS-Interface even faster with the new G12 modules

## Feature Overview

The new G12 builds on the strength of its successful predecessors and adds many new and unique features. At P+F we never design anything but the best, and it shows: Stainless steel mounting base and mounting bar; gold-plated, machined piercing contacts; and SPEEDCON M12 metal inserts are just the beginning.

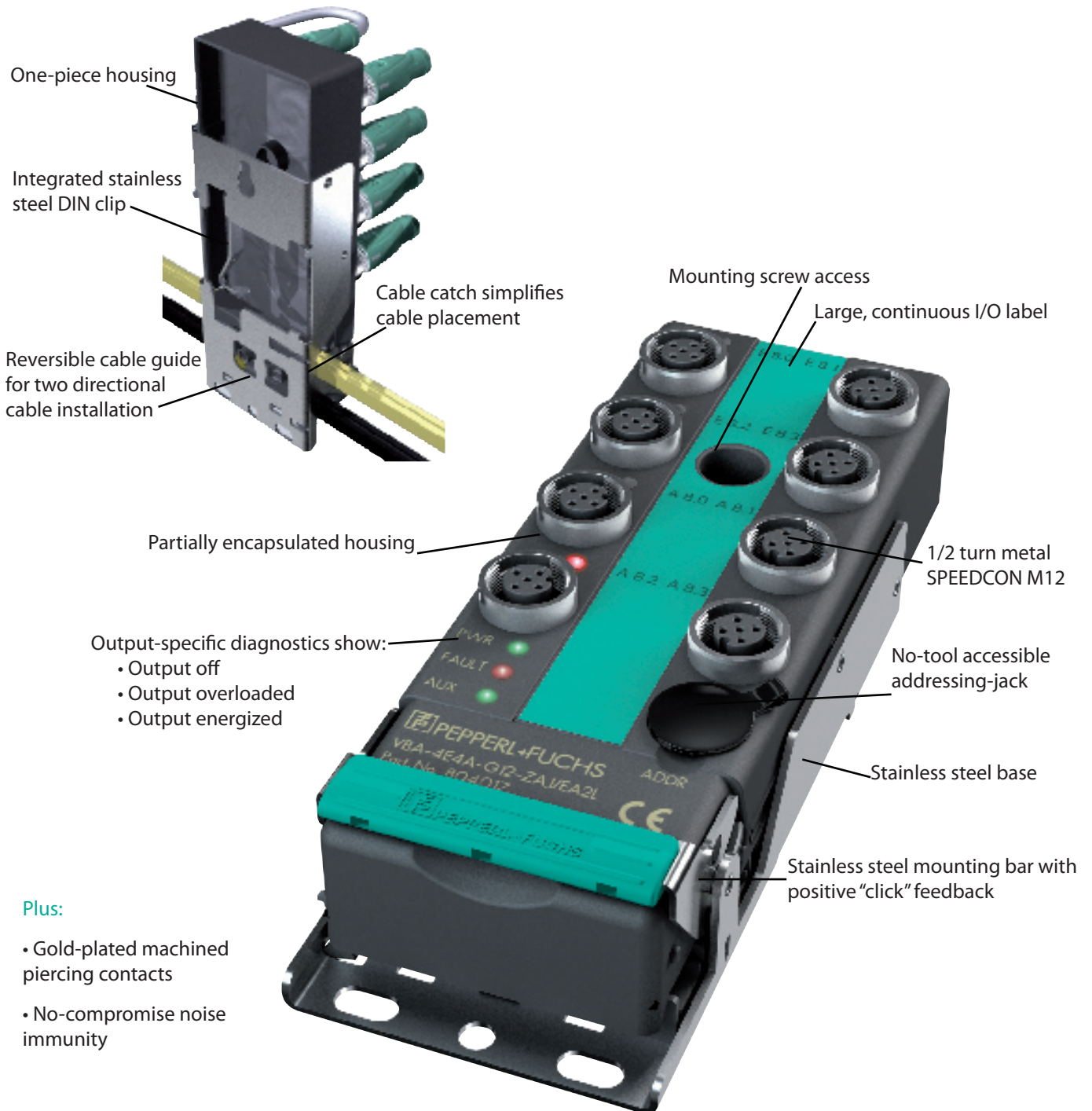

### Plus:

- Gold-plated machined piercing contacts
- No-compromise noise immunity

## The right model for every application!

Model Number	AS-Interface G12 flat module with ...
VBA-4E-G12-ZAJ	4 inputs in short housing style
VBA-4E4A-G12-ZAJ/EA2L*	4 inputs and 4 outputs in long housing style
VAA-4E4A-G12-ZAJ/EA2L	4 inputs and 4 outputs in long housing style
VBA-2E2A-G12-ZAJ/EA2L	2 inputs and 2 outputs in short housing style
VAA-2E2A-G12-SAJ/EA2L	2 safe inputs and 2 outputs in short housing style
VAA-4A-G12-EA2L	4 outputs in short housing style

\* With extended A/B addressing, spec. 3.0 master with M4 profile support required

Why we are building the fastest, and the most advanced AS-Interface?

I/O modules are the essence of the AS-Interface system. All communication passes through the modules. They drive the solenoids and relays, initiate the valves, and enable the pushbuttons. Pepperl+Fuchs' mission is to build the best products at a competitive price and take the guesswork out of selecting the right part for your AS-Interface system. Guided by this principle, G12 has what it takes to survive in today's demanding applications; with uncompromised quality at a surprising price.

