

MANUAL

**VAA-2E2A-G12-
SAJ/EA2L**
**AS INTERFACE SAFETY AT
WORK**
VERSION 1.0

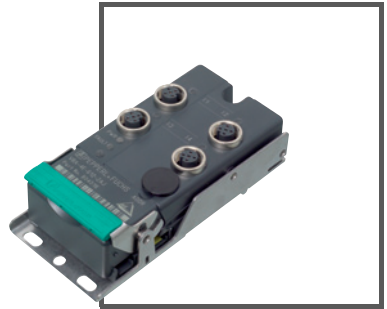



With regard to the supply of products, the current issue of the following document is applicable: The General Terms of Delivery for Products and Services of the Electrical Industry, published by the Central Association of the Electrical Industry (Zentralverband Elektrotechnik und Elektroindustrie (ZVEI) e.V.) in its most recent version as well as the supplementary clause: "Expanded reservation of proprietorship"

1	Declaration of Conformity	5
2	Safety	6
2.1	Used Symbols.....	6
2.2	Intended use	6
2.3	General notes on safety.....	7
2.4	Safety monitor requirements.....	7
2.5	Wiring requirements.....	7
2.6	Switch or mechanical contact requirements	7
2.7	Transfer time of safety-relevant information.....	8
2.8	PFD calculation	8
3	Product description	9
3.1	LED indicators and control buttons	9
3.2	Interfaces and connections.....	10
3.3	Scope of supply.....	11
3.4	Accessories	11
4	Installation	12
4.1	Input connections	12
4.2	AS interface	13
4.3	Auxiliary power.....	14
5	Commissioning	15
5.1	Configuration of the AS interface safety monitor	15
5.2	Module addressing.....	15
5.3	Function tests.....	15
5.4	Operating mode.....	15

6	Operation.....	16
6.1	Operating principle	16
6.1.1	Safety-integrated inputs	16
6.1.2	Cross circuit monitoring of inputs.....	17
6.1.3	Safety classification	17
6.1.4	Non safety-integrated outputs.....	17
7	Maintenance and repair	19

1 Declaration of Conformity

This product has been developed and manufactured in accordance with applicable European standards and directives.



Note!

A Declaration of Conformity can be requested from the manufacturer.

The manufacturer of this product, Pepperl+Fuchs GmbH, in D-68307 Mannheim, Germany, has a certified quality management system in accordance with ISO 9001.



2 Safety

2.1 Used Symbols

Safety-relevant Symbols



Danger!

This symbol indicates a warning about a possible danger.

In the event the warning is ignored, the consequences may range from personal injury to death.



Warning!

This symbol indicates a warning about a possible fault or danger.

In the event the warning is ignored, the consequences may course personal injury or heaviest property damage.



Caution!

This symbol warns of a possible fault.

Failure to observe the instructions given in this warning may result in the devices and any connected facilities or systems develop a fault or fail completely.

Informative Symbols



Note!

This symbol brings important information to your attention.



Action

This symbol marks an acting paragraph.

2.2 Intended use

When used as intended, the AS interface safety module allows the operation of sensor-controlled personal protective equipment up to category 4/PL e as per ISO 13849-1 or up to SIL 3 as per EN/IEC 61508 in combination with an appropriately programmed AS interface safety monitor.



Danger!

Incorrect device connection.

Do not use the outputs for safety-integrated functions.

Approvals

The device is approved in accordance with ISO 13849-1 and EN/IEC 61508.

2.3 General notes on safety

Operating the handheld in a way different from that described in these instructions may have a negative effect on the reliability and function of the device and connected systems. Protection of operating personnel and the overall system is no longer guaranteed if the device is not used as specified.

Installation and commissioning of all devices must be performed by a trained professional only.

Only instructed specialist staff may operate the device in accordance with the operating manual.

In case of changes at the device by the customer the claim for warranty expires. The manufacturer will not longer be liable for defects and malfunctions. Decommission the device in case of a severe failure and make sure that the device can not be commissioned by mistake. Send the device to Pepperl+Fuchs for Repair.

Only qualified electrical specialists are authorized to perform maintenance work.

Do not open the device.

Maintain ambient conditions for IP67.

The operating company bears responsibility for observing locally applicable safety regulations.

2.4 Safety monitor requirements

The device should only be used as a safety-integrated slave in an AS interface thread with corresponding AS interface safety monitor in accordance with specifications. The AS interface safety monitor must fulfill the requirements described in system specifications "Specifications for safer AS interface transfer", version 2.01 from 12.05.2000.

In order to evaluate a safety-integrated function in accordance with a safety standard, all components of the function must be evaluated in accordance with this safety standard.

The circuit and programming of the safety monitor also determine whether the required safety function is performed correctly. This also applies to the required safety response after a code fault or failure (see also safety monitor documentation). The security function (including all safety-relevant sensors) should be checked before the system is commissioned for the first time. The category or the SIL of the safety monitor must correspond to the category or SIL required for the application.

2.5 Wiring requirements

The requirements stipulated in EN/IEC 60204-1 (or similar) must be fulfilled at all times. Requirements for external wiring and the selection of connected sensors are based on functional requirements and the relevant category (ISO 13849-1 or EN/IEC 61508).

2.6 Switch or mechanical contact requirements

The switches must be spring loaded. Switches combinations that guarantee an equivalent safety status (malfunction analysis) can be used.

2.7 Transfer time of safety-relevant information

The transfer time depends mainly on the monitor. Read the corresponding documentation and actuating element disconnecting times.

2.8 PFD calculation

When calculating the PFD (probability of dangerous failure on demand) of a safety-integrated function, the PFD values of all components used in this function must be taken into consideration. The AS interface safety slave does not make a significant contribution to PFD or PFH (probability of dangerous failure per hour) for the overall system.

Refer to the relevant documentation for information on the PFD or PFH values of other components, in particular the safety monitor.

3 Product description

3.1 LED indicators and control buttons

The device has the following indicators:

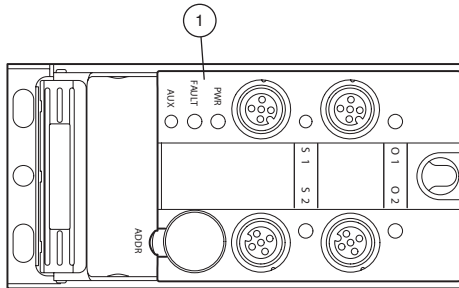

1. Status indicators

Indicators

Designation	Description
FAULT	Fault indicator; LED red <ul style="list-style-type: none"> Red: communication error or address is 0 Red flashing: output supply overload
PWR	AS interface voltage; LED green <ul style="list-style-type: none"> Green: voltage OK Green flashing: address 0
AUX	External bulk power UAUX; dual LED green/red <ul style="list-style-type: none"> Green: voltage OK Red: voltage, poles reversed
S1	Switching status of input channel 1; LED yellow
S2	Switching status of input channel 2; LED yellow
OUT1	Switching status of output 1; LED yellow/red <ul style="list-style-type: none"> Yellow: output active (AUX+ connected through) Red: output overload
OUT2	Switching status of output 2; LED yellow/red <ul style="list-style-type: none"> Yellow: output active (AUX+ connected through) Red: output overload

3.2 Interfaces and connections

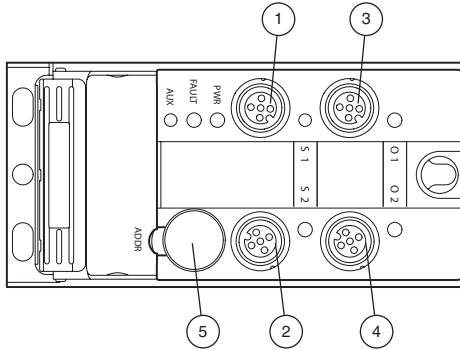

1. Safe input 1
2. Safe input 2
3. Output 1
4. Output 2
5. Addressing socket

Safety-integrated inputs

Socket	PIN	Description	Designation
S1	1	Mechanical switch 1+	S1+
	2	Mechanical switch 1-	S1-
	3	Mechanical switch 2+	S2+
	4	Mechanical switch 2-	S2-
	5	reserved	
S2	1	Mechanical switch 2+	S2+
	2	Mechanical switch 2-	S2-
	3	Not assigned	
	4	Not assigned	
	5	reserved	

Table 3.1: The pins 5 are reserved and should not be assigned.

Non safety-integrated outputs

Socket	PIN	Description	Designation
OUT1	1	Not assigned	
	2	Output 2 +	OUT2
	3	Output -	AUX-
	4	Output 1 +	OUT1
	5	Not assigned	
OUT2	1	Not assigned	
	2	Not assigned	
	3	Output -	AUX-
	4	Output 2 +	OUT2
	5	Not assigned	
Flat cable connection		External bulk power +	AUX+
		External bulk power -	AUX-
		AS interface +	
		AS interface -	

3.3 Scope of supply

The following are included in the scope of supply:

- Safety module
- Jumper
- Blank plug
- Documentation

3.4 Accessories

Jumper

To assign a single mechanical switch to the device (e.g. emergency-stop category 2), attach a jumper to the vacant socket on the emergency-stop connection. Insert the blank plug supplied into the vacant socket to protect this jumper from dirt and prevent it from falling out.

4 Installation

4.1 Input connections

The switches are connected to M12 sockets. One or more series-connected mechanical switch can be connected for each channel.

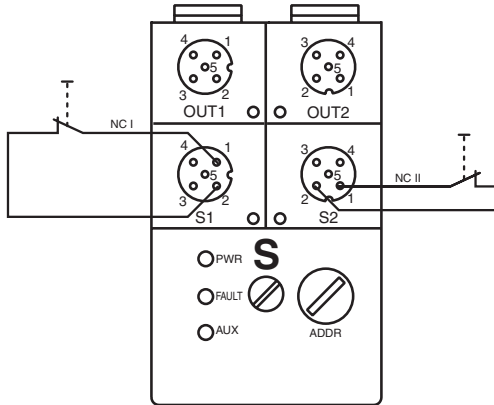

If a single-channel switch is used, use input 1.

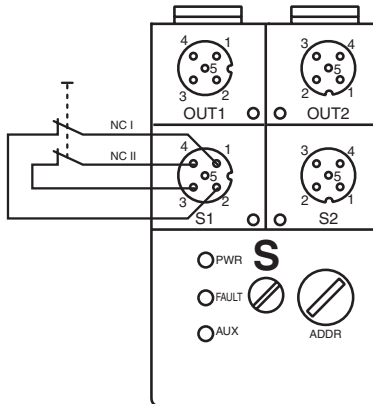

If input 2 remains blank, connections S2+ to S2- on the input must be bridged using the accompanying jumper. Secure the jumper using a blank plug VAZ-V1-B.

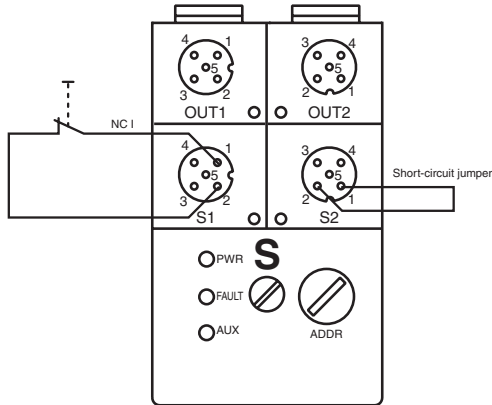

Figure 4.1: 1 mechanical switch

**Warning!**

Electrical termination caused by moisture

The specified protection degree and the security function may not be guaranteed if the cable duct is not sealed correctly.

- Fit protective caps (e.g. VAZ-V1-B) to vacant connectors.
- Use rubber seals (e.g. VAZ-FK-ST1) for the cable ends.

4.2 AS interface

The G12 series module is connected to the AS interface via the integrated metal base. The components are connected by a yellow AS interface flat cable, e.g. VAZ-FK-S-YE.

**Warning!**

Electrical termination caused by moisture

The specified protection degree and the security function may not be guaranteed if the cable duct is not sealed correctly.

- Fit protective caps (e.g. VAZ-V1-B) to vacant connectors.
- Use rubber seals (e.g. VAZ-FK-ST1) for the cable ends.

4.3 Auxiliary power

The G12 series module is connected to the auxiliary power supply via the integrated metal base. The components are connected by a black AS interface flat cable, e.g. VAZ-FK-S-BK.



Warning!

Electrical termination caused by moisture

The specified protection degree and the security function may not be guaranteed if the cable duct is not sealed correctly.

- Fit protective caps (e.g. VAZ-V1-B) to vacant connectors.
- Use rubber seals (e.g. VAZ-FK-ST1) for the cable ends.

5 Commissioning

5.1 Configuration of the AS interface safety monitor

Please refer to the safety monitor documentation for information on required organizational measures that affect the configuration of the safety monitor.

5.2 Module addressing

The module is addressed using a handheld reader or an AS interface master device. When using the handheld reader, connect the reader to the addressing socket on the module using the addressing cable supplied (marked with ADDR). Addresses 1 to 31 can be assigned. 0 is the default address on delivery.

5.3 Function tests

Function tests must be performed during installation. The function test reveals all current errors at the time of the installation. Tests for short circuits in the wiring are not required because the safe inputs are cross circuit monitored.

5.4 Operating mode

Activating operating modes for the inputs is not possible.

The parameters in the AS interface may influence the performance of the outputs. The chapter "Operating principle" contains a more accurate description.

6 Operation

Programming the safety monitor parameters defines the safety function of the device. Read the corresponding documentation.

6.1 Operating principle

6.1.1 Safety-integrated inputs

The module generates an internal code sequence. A safety monitor (other node) monitors this code sequence to make sure it is correct.

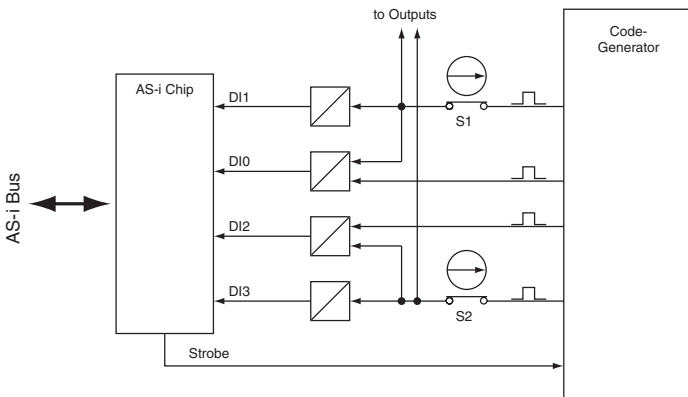

The transfer of the code sequence is influenced by the status of the externally connected mechanical switches.

Information on the activation status of connected mechanical switches (e.g. if emergency-stop actuated, code transfer interrupted) is transferred as follows:

Activated input channel	Code
	4 3 2 1
1	X X 0 0
2	0 0 X X
1 and 2	0 0 0 0
none	X X X X

The code words 0000, XX00 and 00XX prompt the safety monitor to make the status of the system safe (for example via the emergency-stop button) without triggering a fault message. If a bit from a code word deviates from the target code word, the safety monitor switches the system to safe status and signals a slave fault.

The two input channels on the safety module are interdependent. The safety monitor can be programmed to monitor the synchronicity of the two inputs for dual-channel applications.

6.1.2 Cross circuit monitoring of inputs

The inputs are monitored for cross circuits. The cross circuit monitoring function is able to detect low-ohm cross circuits caused by a metallic connection between the two inputs.

6.1.3 Safety classification

The module contains two interdependent, redundant input channels. If both input channels are used, the module is suitable up to category 4/PL e as per ISO 13849-1 or SIL 3 as per EN/IEC 61508. The monitor must be programmed to monitor dual-channel switching.

If two single-channel switches are used, the module is suitable up to category 2/PL c as per ISO 13849-1 or SIL 2 as per EN/IEC 61508.

6.1.4 Non safety-integrated outputs

The outputs are designed in line with AS interface standards. Positive potential is applied to these outputs (PNP technology).

The status of the outputs is either determined by the master device or derived from the status of the inputs, depending on the operating mode set via the parameters on the AS interface master device.

The outputs can be operated in two modes:

- The outputs are controlled directly by the AS interface master device via the related data bits.
- The output signals from the AS interface master device are linked with the safe inputs. The outputs are activated by the master device or when the status of the inputs is safe. The purpose of this operating mode is to control signal lamps which indicate the status of the inputs without assistance from the master device.

Mode and logic table for outputs

The master device selects the modes via parameter bit P1:

P1	S1 / S2 ¹⁾	DO0 / DO1 ²⁾	OUT1 / OUT2	Mode
1	X / X	0 / 0	0 / 0	Outputs independent from the inputs
	X / X	1 / 1	1 / 1	
0	0 / 0	X / X	1 / 1	Open switch at input sets the related output
	1 / 1	0 / 0	0 / 0	The master device controls the output if the switch at the input is closed
	1 / 1	1 / 1	1 / 1	

Table 6.1: ¹⁾ 0 refers to an open switch (safe status). 1 means a closed switch. X means any status that does not effect the outputs.

²⁾ 1 means outputs are activated, 0 means outputs are voltage-free.

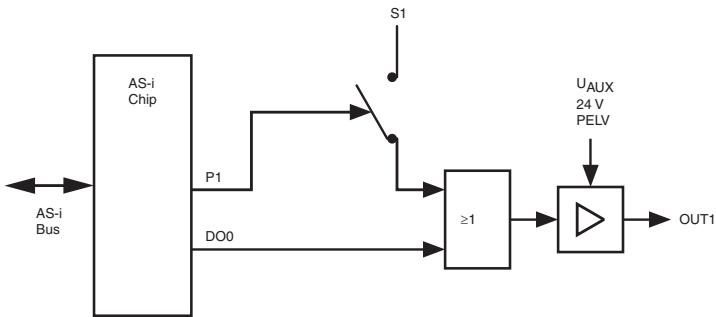

7 Maintenance and repair

Regular function tests may be necessary, depending on the safety category.

FACTORY AUTOMATION – SENSING YOUR NEEDS



Worldwide Headquarters

Pepperl+Fuchs GmbH
68307 Mannheim · Germany
Tel. +49 621 776-0
E-mail: info@de.pepperl-fuchs.com

USA Headquarters

Pepperl+Fuchs Inc.
Twinsburg, Ohio 44087 · USA
Tel. +1 330 4253555
E-mail: sales@us.pepperl-fuchs.com

Asia Pacific Headquarters

Pepperl+Fuchs Pte Ltd.
Company Registration No. 199003130E
Singapore 139942
Tel. +65 67799091
E-mail: sales@sg.pepperl-fuchs.com

www.pepperl-fuchs.com

 **PEPPERL+FUCHS**
SENSING YOUR NEEDS