

LUCIFER®

Electropneumatic pressure regulator EPP4 Series

Connection G 1/4

Catalogue 8683/GB



EPP4 basic



THE economic solution which meets the market requirements

Compact design and lightweight for ease of installation and low inertia on moving robots.

High responsiveness and low Hysteresis (0.5%) for accurate and fast adjustment of the controlled pressure.

Low power consumption (2.2W), energy savings compatible with environment protection.

The product

An **electropneumatic** pressure regulators G 1/4 which, by means of an integrated electronic control system and pulse width modulated solenoid valves, controls the output pressure proportionally to an analogue electrical signal. A high precision is achieved by means of an internal feedback through an integrated pressure sensor.

Applications

Pressure control independent of flow in electropneumatic control systems, in particular in the following industries:

- Robotics: welding, painting lines
- Paper and printing: tension regulations, speed-and brake control for rolls
- Machine tools: plastic moulding, laser welding, presses, polishing
- Trucks and Trains: control of adaptive suspensions.

Benefits

- Simplification of control systems by reducing the number of components and permitting more flexibility of the controls with non negligible increase of the productivity (performances, quality, reliability)
- Very fast response times
- Excellent linearity and hysteresis
- No air consumption in rest position
- Direct interface to programmable controllers.



Welding robot

Printing machine

TECHNICAL DATA

Fluid:	Lubricated or non lubricated air and neutral gases. Recommended filtration: 50 μ
Temperature range :	Ambient : 0 to +50 °C. Fluid : 0 to +50 °C.
Inlet pressure range :	1 to 12 bar (the inlet pressure must always be at least 1 bar above the regulated pressure)
Outlet pressure range :	0.05 to 10 bar
Hysteresis :	< 50 mbar (factory set up).
Air consumption at constant control signal :	0
Supply voltage :	24 V DC \pm 15 % (Max. ripple 1 V)
Power consumption:	Max. 2.2 W with 24 V DC and constant changes of the control signal < 0.5 W without change of control signal
Control signal :	Analog 0 - 10 V Analog 4 - 20 mA
Indicative reponse time :	With a volume of 330 cm ³ at the outlet of the regulator. Filling : 2 to 4 bar - 2 to 8 bar Step response : ~ 50 ms - ~ 100 ms Emptying : 4 to 2 bar - 8 to 2 bar Step response : ~ 70 ms - ~ 130 ms
Safety position :	In case of control signal failure or if it is less than 50mV, the regulated pressure drops automatically to 0 bar (atmospheric pressure). In case of voltage supply failure, the regulated pressure will be kept constant
Electrical connection :	M12 – 4 pin ; 4x 0.34mm ²
Life expectancy :	> 50 Mio changes of control signal steps.
Mounting position :	Indifferent (recommended position: upright; electronic part on top).
Resistance to vibrations :	30 g in all directions.
Outlet signal:	No outlet signal.
Degree of protection:	IP 65.
Assembly :	Silicone free
Electromagnetic compatibility :	In accordance with EN 61000-6-1:2001 EN 61000-6-2:2001 EN 61000-6-3:2001 EN 61000-6-4:2001
Installation and setting instructions:	See our 12 pages " Bulletin 408014 " and appendix supplied with the product.

Note: Parker Lucifer reserves the right to change specifications without notification.

Description of operation

The EPP4 Series is a family of electrically remote-controlled pneumatic pressure regulators with closed loop integrated electronic control. It allows regulating the outlet pressure proportionally to an electrical control signal. The EPP4 regulator comprises a traditional servo-operated pneumatic pressure regulator, where the pilot chamber is fed by one or the other of two pulse width modulated 2-way solenoid valves.

The pressure sensor measures the outlet pressure of the regulator and provides a feedback signal to the controller. Any difference between the control signal and the feedback signal is converted to a digital signal to energise the coil of one or the other 2-way valves to correct the position of the regulator.

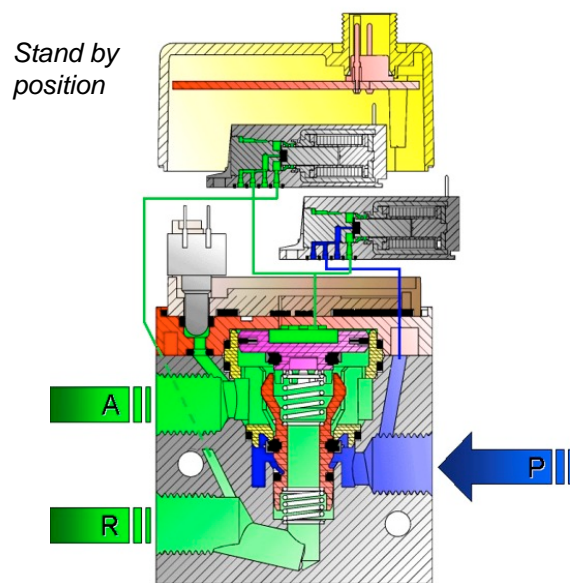

The control signal can be a voltage (0-10 V) or a current (4-20 mA). The inlet of the "filling valve" is connected directly to the main inlet P of the regulator; when energised this valve will fill the servo-chamber for increasing the pressure at the outlet A of the regulator.

When the other "exhaust valve" is energised (reduction of pressure at the outlet A of the regulator), the pressure of the servo-chamber will be exhausted through a discharge orifice located between the cover and the body and directly fed to the atmosphere without silencer.

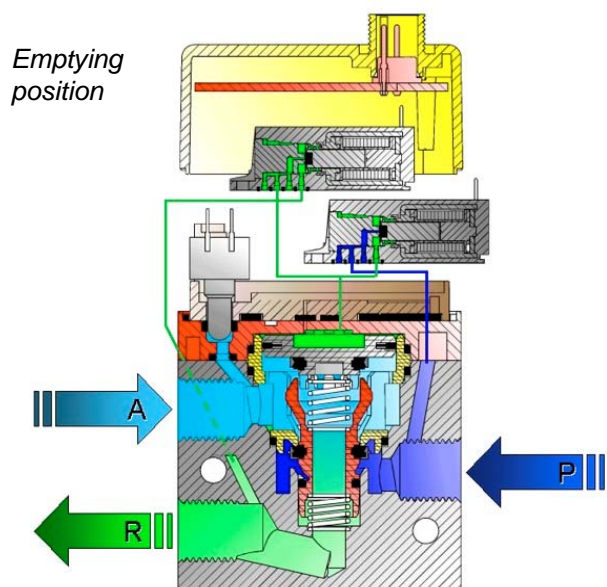
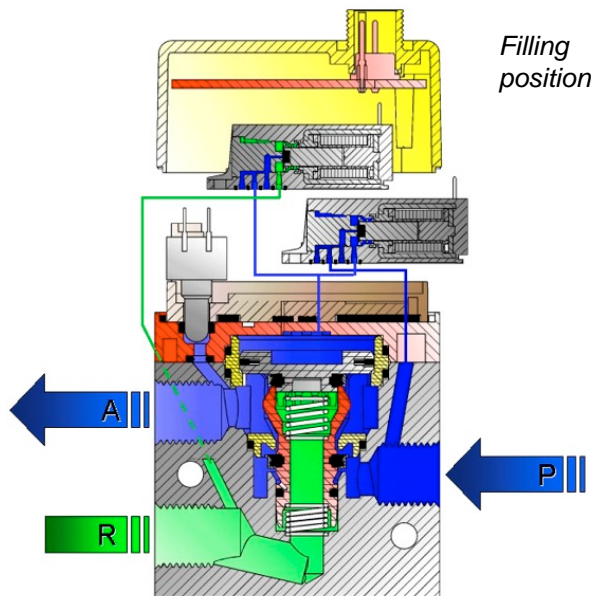

An option exists to collect the exhaust via the quick exhaust R (Upon request). The exhaust of the main regulated pressure will be made through the quick exhaust R. The use of a conventional silencer is recommended.

Both solenoid valves assure the filling or emptying of the servo-chamber in order to increase or decrease the pressure at the outlet of the regulator. In rest position of the valves all ports are blocked.

Block diagram

The controller receives both the control signal (set pressure) and the feedback signal from the sensor (outlet pressure).

Any difference between the two amplifier inputs results in a corresponding output which drives the appropriate 2-way pulse width modulated solenoid valve so that the pilot piston moves to correct the pressure.

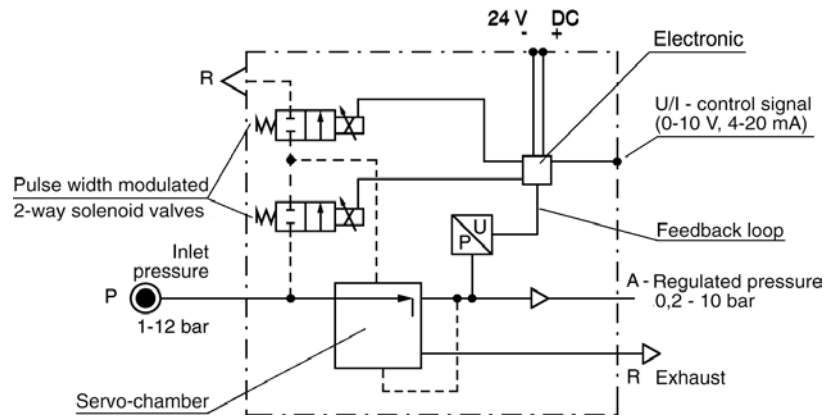

Hysteresis diagram

Flow data

Outlet pressure in function of flow at constant control signal (P1 = 10 bar)

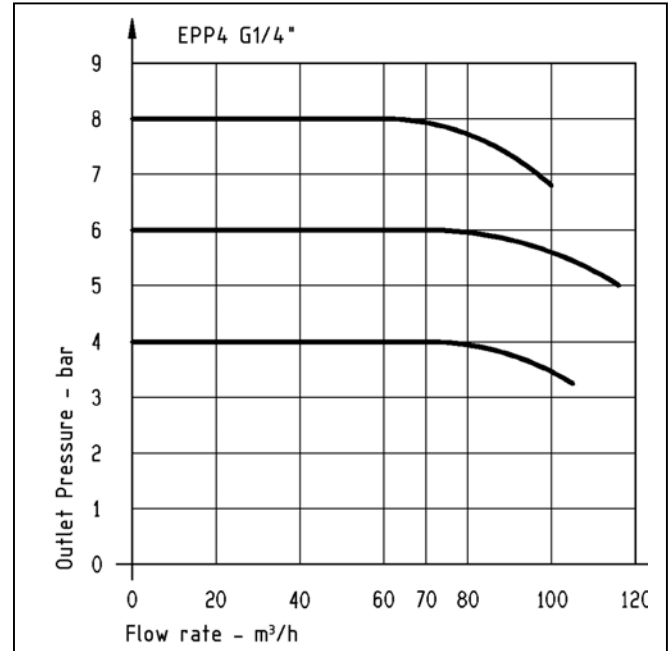
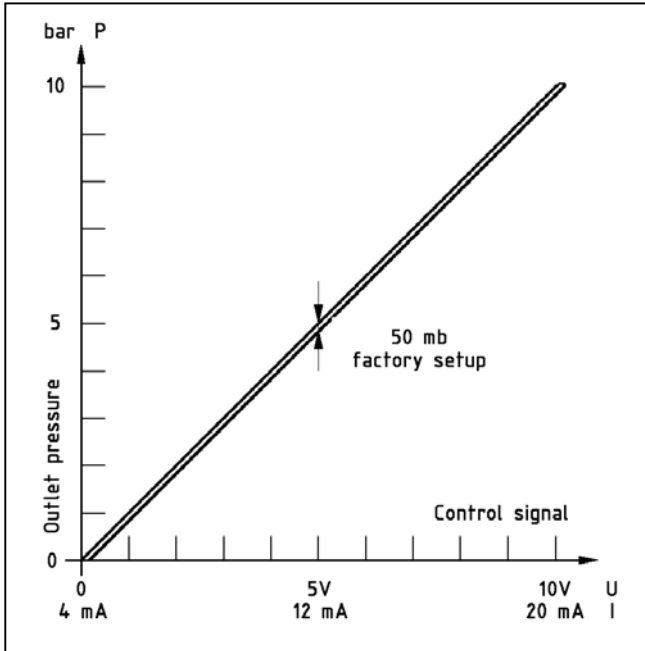

Dimensions

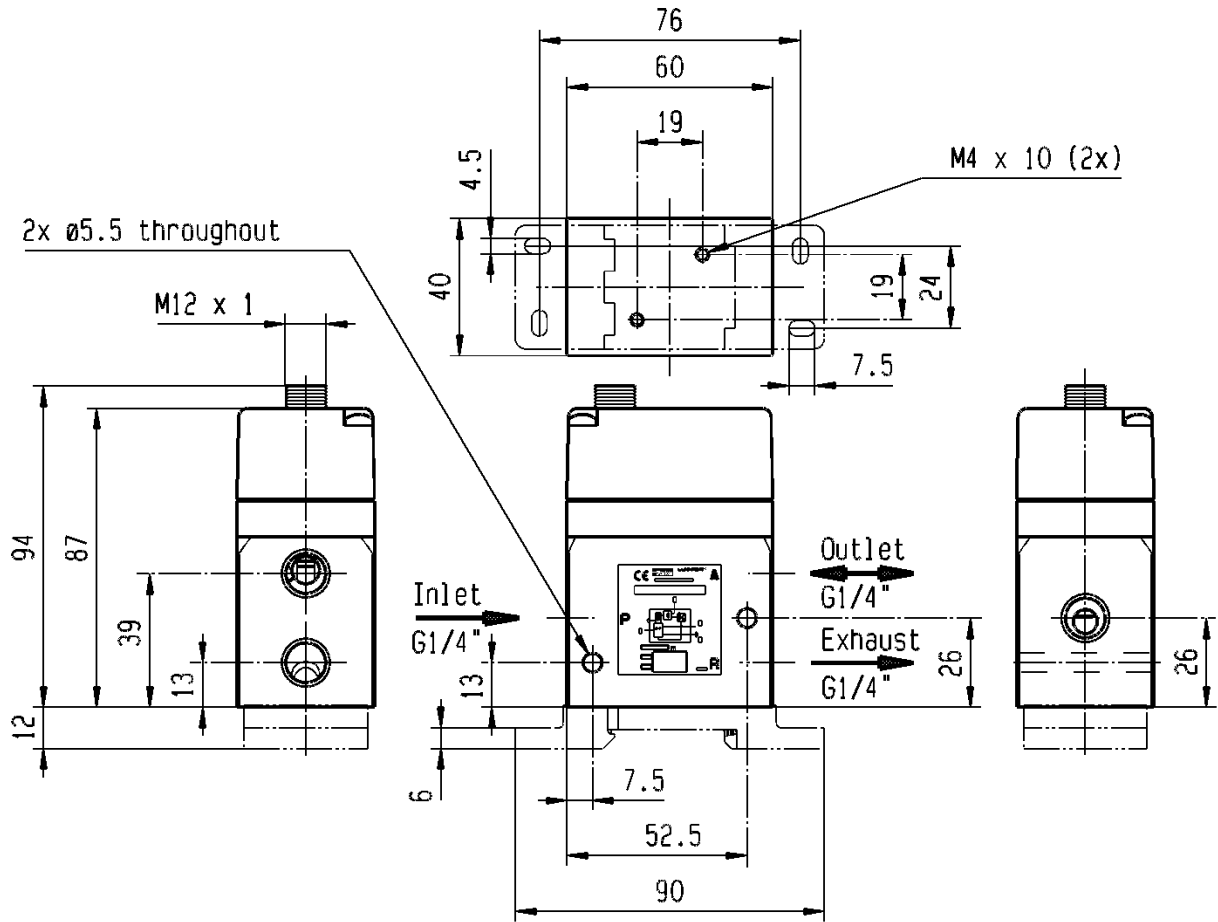

Accessories

Mounting bracket (automatically supplied with each EPP4)

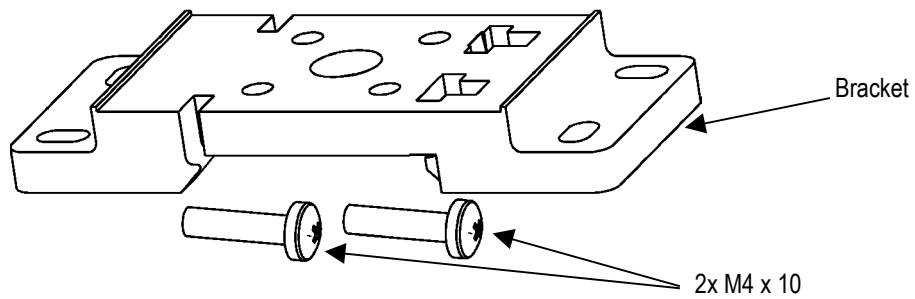

How to order:

Reference	Control signal	Outlet pressure
P4BG2001A002	0 - 10V	0 - 10bar
P4BG2001A003	4 - 20mA	0 - 10bar

Ask your agent for any specific calibration.
 Cable + connector not included.

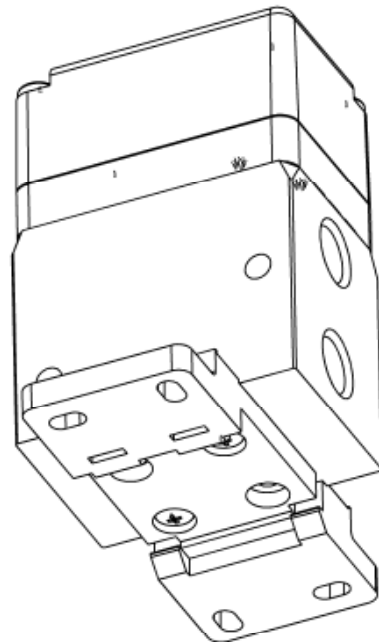
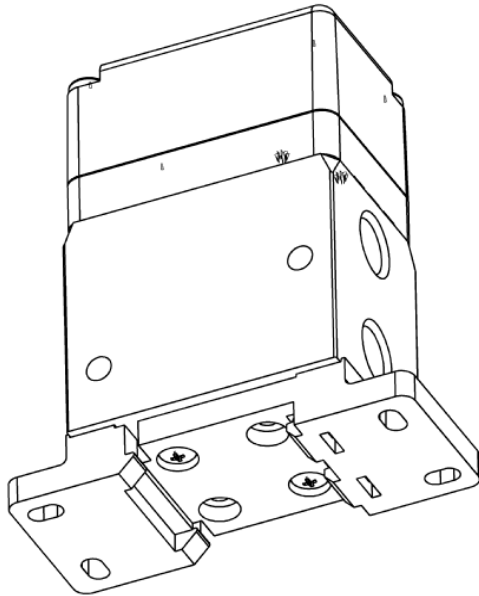



Parker Lucifer SA

Fluid Control Division Europe

16, ch. du Faubourg de Cruseilles

1227 Carouge/Geneva – Switzerland

Tel. +41 22 307 71 11 – Fax. +41 22 307 71 10

www.parker.com/lucifer

8683/GB
Jan. 05