

64 Series Pressure Reducing Regulators



W1943

Figure 1. 64 Series Regulator

Introduction

The 64 Series regulators are spring-loaded, direct-operated devices typically used to deliver constant reduced pressure of gaseous fluids to pilot-operated controllers and other pneumatic instrumentation.

As shown in the Available Configuration section of the Specifications section, an assortment of regulators are available to meet diverse flow requirements. The Type 64R has internal relief capacity to minimize overpressure in small capacity systems. When the reduced pressure in these regulators rises above the pressure setting and lifts the diaphragm, excess pressure flows into the spring case through a drilled orifice in the diaphragm plate (Figure 2) and bleeds out through a screened vent (Figure 4) in the spring case.

Features

- **Versatility**—Although typically used for air regulation, the 64 Series product line can control a variety of gases including anhydrous ammonia (NH_3) and sour gas.
- **Body Side Connection**—A side outlet (shown in Figure 4) can be used as a convenient tap for a pressure gauge.
- **Easy Maintenance**—Trim parts can be easily removed for inspection without removing the regulator from the pipeline.
- **Sour Gas Service Capability**—Optional materials are available for applications handling sour gases. These constructions comply with the recommendations of National Association of Corrosive Engineers (NACE) MR-01-75.



Bulletin 71.1:64

Specifications

Available Configurations

Type 64: Basic regulator for 3 to 15 psig (0,21 to 1,03 bar) outlet pressures

Type 64R: Internal relief version of Type 64

Type 64B: NH₃ service version of Type 64

Connections

End: 1/2-inch NPT

Side Outlet: 1/4-inch NPT

Maximum Allowable Pressures

Inlet: 250 psig (17,2 bar)

Operating Outlet: 150 psig (10,3 bar)

Emergency Outlet: 220 psig (15,2 bar)

Outlet Pressure Ranges

See Table 1

Port Diameter

1/4-inch (6,35 mm)

Capacities

See Table 2 and Figure 3

Coefficients for Relief Valve Sizing

Wide Open C_g: 35.6

Wide Open C₁: 39.0

Temperature Capabilities

-20° to 150°F (-29° to 66°C)

Pressure Registration

Internal

Spring Case Vent

1/4-inch NPT with screen

Outlet Pressure Gauge Connection

1/4-inch NPT

Weight

2.25 pounds (1,01 kg)

Options

- Closing cap for adjusting cap screw
- Triple scale outlet pressure gauge (brass or stainless steel)
- PTFE Diaphragm Protector

Construction Materials

Body: Die-cast aluminum

Spring Case: Die-cast aluminum or cast iron

Disk Holder Assembly: Brass, neoprene and

FKM or stainless steel and neoprene

Stem Guide: Brass or stainless steel

Diaphragm: Nitrile, FKM

Valve Stem: Stainless steel

Regulator Spring: Steel or Inconel X750

(Type 64R only)

Relief Valve Seat (Type 64R): Stainless steel or brass

1. The pressure/temperature limits in this bulletin or any applicable standard limitation should not be exceeded.

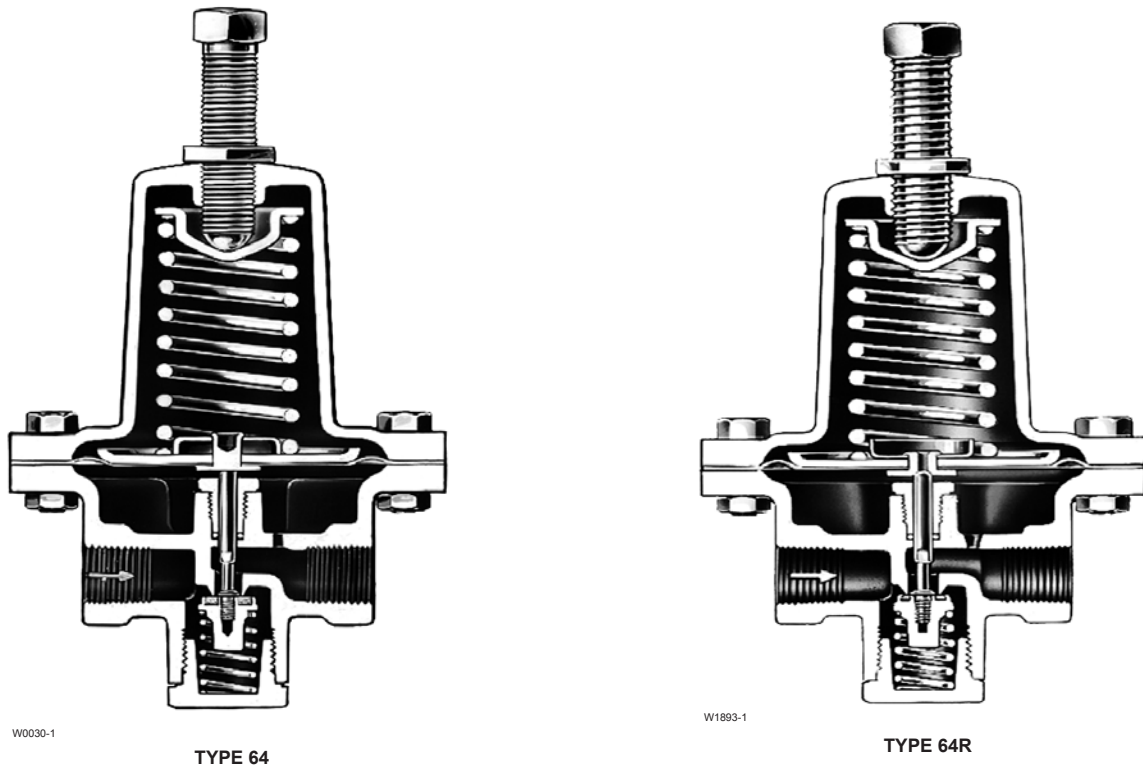

Figure 2. Typical Constructions

Overpressure Protection

Like most regulators, the 64 Series regulators have outlet pressure ratings lower than their inlet pressure rating. Although the internal relief valve provides limited downstream overpressure protection, complete downstream protection is needed if the actual inlet pressure exceeds the outlet pressure rating.

Overpressuring any portion of a 64 Series regulator may cause regulator leakage, damage to regulator parts, or personal injury due to bursting of pressure-containing parts or explosion of accumulated gas. Provide appropriate overpressure protection devices to ensure that none of the limits in the Specifications section or Table 1 will be exceeded.

Regulator operation below these limits does not preclude the possibility of damage from external sources or from debris in the gas line. The regulator should be inspected for damage after any overpressure condition.

Installation

These regulators may be installed in any position as long as the screened vent (shown in Figure 4) is protected from debris, weather, or anything else that might clog it. Figure 4 shows the dimensions of the 64 Series regulators in both inches and millimeters.

Bulletin 71.1:64

Table 1. Outlet Pressure Ranges and Spring Selections

OUTLET PRESSURE RANGE, Psig (bar)	SPRING PART NUMBER	SPRING COLOR
3 to 15 (0,2 to 1,0)	1D892327022	Red
3 to 20 (0,2 to 1,4)	1D751527022	Silver
5 to 35 (0,34 to 2,4)	1D665927022	Blue
30 to 60 (2,1 to 4,1)	1D745527142	Green
35 to 100 (2,4 to 6,9)	1E543627142	Yellow
80 to 150 (5,5 to 10,3) ⁽¹⁾	1P901327142	Brown

1. Cannot be used in anhydrous ammonia (NH₃) applications.

Table 2. Air Capacities

OUTLET PRESSURE RANGE, PSIG (bar)	OUTLET PRESSURE SETTING, PSIG (bar)	INLET PRESSURE, PSIG (bar)	CAPACITIES IN SCFH (Nm ³ /h) OF AIR		
			5% Offset	10% Offset	20% Offset
3 to 15 (0,2 to 1,0)	5 (0,34)	10 (0,69)	400 (10,7)	525 (14,1)	650 (17,4)
		15 (1,0)	450 (12,1)	750 (20,1)	900 (24,1)
		25 (1,7)	475 (12,7)	1100 (29,5)	1325 (35,5)
		50 (3,4)	600 (16,1)	1400 (37,5)	2200 (59,0)
		100 (6,9)	1200 (32,2)	1800 (48,2)	2300 (61,6)
		150 (10,3)	1400 (37,5)	1800 (48,2)	2300 (61,6)
	10 (0,69)	15 (1,0)	525 (14,1)	700 (18,8)	800 (21,4)
		25 (1,7)	700 (18,8)	1175 (31,5)	1300 (34,8)
		50 (3,4)	1300 (34,8)	2100 (56,3)	2300 (61,6)
		100 (6,9)	1700 (45,6)	2400 (64,3)	2700 (72,4)
		150 (10,3)	2000 (53,6)	2600 (69,7)	2800 (75,0)
		250 (17,2)	2200 (59,0)	2600 (69,7)	2800 (75,0)
15 (1,0)	25 (1,7)	700 (18,8)	1100 (29,5)	1200 (32,2)	
	50 (3,4)	1000 (26,8)	2100 (56,3)	2200 (59,0)	
	100 (6,9)	2100 (56,3)	2600 (69,7)	2800 (75,0)	
	150 (10,3)	2400 (64,3)	2700 (72,4)	3000 (80,4)	
	250 (17,2)	2600 (69,7)	2800 (75,0)	3000 (80,4)	
	2600 (69,7)	2800 (75,0)	3000 (80,4)	3000 (80,4)	
3 to 20 (0,2 to 1,4)	5 (0,34)	15 (1,0)	350 (9,38)	550 (14,7)	810 (21,7)
		50 (3,4)	575 (15,4)	1100 (29,5)	1800 (48,2)
		100 (6,9)	1200 (32,2)	1800 (48,2)	2200 (59,0)
		150 (10,3)	1600 (42,9)	2100 (56,3)	2500 (67,0)
		250 (17,2)	1600 (42,9)	1750 (46,9)	2400 (64,3)
	10 (0,69)	20 (1,4)	450 (12,1)	800 (21,4)	1050 (28,1)
		50 (3,4)	900 (24,1)	1700 (45,6)	2200 (59,0)
		100 (6,9)	1400 (37,5)	2100 (56,3)	2600 (69,7)
		150 (10,3)	1800 (48,2)	2300 (61,6)	2700 (72,4)
		250 (17,2)	2000 (53,6)	2400 (64,3)	2800 (75,0)
	20 (1,4)	25 (1,7)	600 (16,1)	900 (24,1)	1050 (28,1)
		30 (2,1)	800 (21,4)	1200 (32,2)	1350 (36,2)
35 (2,4)		900 (24,1)	1375 (36,9)	1560 (41,8)	
50 (3,4)		1300 (34,8)	2100 (56,3)	2200 (59,0)	
100 (6,9)		2200 (59,0)	2500 (67,0)	2800 (75,0)	
5 to 35 (0,34 to 2,4)	5 (0,34)	15 (1,0)	300 (8,04)	375 (10,1)	550 (14,7)
		50 (3,4)	400 (10,7)	650 (17,4)	1100 (29,5)
		100 (6,9)	600 (16,1)	1100 (29,5)	1800 (48,2)
		150 (10,3)	900 (24,1)	1350 (36,2)	2200 (59,0)
		250 (17,2)	1200 (32,1)	2100 (56,3)	2500 (67,0)
	15 (1,0)	25 (1,7)	500 (13,4)	750 (20,1)	1100 (29,5)
		50 (3,4)	700 (18,8)	1300 (34,8)	2000 (53,6)
		100 (6,9)	1200 (32,2)	2200 (59,0)	2500 (67,0)
		150 (10,3)	1800 (48,2)	2400 (64,3)	2800 (75,0)
		200 (13,8)	2400 (64,3)	2600 (69,7)	3000 (80,4)
	25 (1,7)	35 (2,4)	650 (17,4)	1100 (29,5)	1400 (37,5)
		50 (3,4)	900 (24,1)	1600 (42,9)	2000 (53,6)
100 (6,9)		1500 (40,2)	2000 (53,6)	2600 (69,7)	
150 (10,3)		2200 (59,0)	2400 (64,3)	2800 (75,0)	
250 (17,2)		2400 (64,3)	2700 (72,4)	3000 (80,4)	
35 (2,4)	45 (3,1)	800 (21,4)	1400 (37,5)	1650 (44,2)	
	50 (3,4)	1050 (28,1)	1600 (42,9)	2000 (53,6)	
	100 (6,9)	2100 (56,3)	2300 (61,6)	2600 (69,7)	
	150 (10,3)	2200 (59,0)	2400 (64,3)	2800 (75,0)	
	250 (17,3)	2600 (69,7)	2800 (75,0)	3000 (80,4)	

- continued -

Table 2. Air Capacities (continued)

OUTLET PRESSURE RANGE, PSIG (bar)	OUTLET PRESSURE SETTING, PSIG (bar)	INLET PRESSURE, PSIG (bar)	CAPACITIES IN SCFH (Nm ³ /h) OF AIR		
			5% Offset	10% Offset	20% Offset
30 to 60 (2,1 to 4,1)	30 (2,1)	40 (2,8)	700 (18,8)	1100 (29,5)	1500 (40,2)
		50 (3,4)	900 (24,1)	1450 (38,9)	2050 (54,9)
		100 (6,9)	1500 (40,2)	2000 (53,6)	2600 (69,7)
		150 (10,3)	2250 (60,5)	2400 (64,3)	2800 (75,0)
		250 (17,2)	2400 (64,3)	2500 (67,0)	3000 (80,4)
	40 (2,8)	50 (3,4)	900 (24,1)	1450 (38,9)	1900 (50,9)
		100 (6,9)	1700 (45,6)	2200 (59,0)	2700 (72,4)
		150 (10,3)	2500 (67,0)	2700 (72,4)	3000 (80,4)
		250 (17,2)	2800 (75,0)	3000 (80,4)	3300 (88,4)
	50 (3,4)	60 (4,1)	1000 (26,8)	1700 (45,6)	2100 (56,3)
		100 (6,9)	2000 (53,6)	2500 (67,0)	3000 (80,4)
		150 (10,3)	2600 (69,7)	3000 (80,4)	3400 (91,1)
250 (17,2)		3000 (80,4)	3300 (88,4)	3800 (102)	
60 (4,1)	70 (4,8)	1300 (34,8)	2000 (53,6)	2400 (64,3)	
	100 (6,9)	2300 (61,6)	2700 (72,4)	3200 (85,8)	
	150 (10,3)	2800 (75,0)	3200 (85,8)	3600 (96,5)	
	250 (17,2)	3200 (85,8)	3600 (96,5)	4000 (107)	
35 to 100 (2,4 to 6,9)	40 (2,8)	50 (3,4)	600 (16,1)	1000 (26,8)	1400 (37,5)
		100 (6,9)	1500 (40,2)	2000 (53,6)	2400 (64,3)
		150 (10,3)	2200 (59,0)	2400 (64,3)	2600 (69,7)
		200 (13,8)	2400 (64,3)	2600 (69,7)	2800 (75,0)
		250 (17,2)	2600 (69,7)	2800 (75,0)	3100 (83,1)
	60 (4,1)	70 (4,8)	800 (21,4)	1300 (34,8)	1800 (48,2)
		100 (6,9)	2100 (56,3)	2500 (67,0)	3000 (80,4)
		150 (10,3)	2400 (64,3)	2700 (72,4)	3200 (85,8)
		200 (13,8)	2700 (72,4)	3000 (80,4)	3500 (93,8)
	80 (5,5)	250 (17,2)	3000 (80,4)	3300 (88,4)	3800 (102)
		90 (6,2)	1400 (37,5)	1900 (50,9)	2200 (59,0)
		100 (6,9)	2200 (59,0)	2500 (67,0)	3000 (80,4)
150 (10,3)		2400 (64,3)	2700 (72,4)	3200 (85,8)	
100 (6,9)	200 (13,8)	2900 (77,7)	3100 (83,1)	3600 (96,5)	
	250 (17,2)	3200 (85,8)	3500 (93,8)	4000 (107)	
	110 (7,6)	1600 (42,9)	2400 (64,3)	2600 (69,7)	
	150 (10,3)	2500 (64,0)	2900 (77,7)	3400 (91,1)	
80 to 150 (5,5 to 10,3)	90 (6,2)	200 (13,8)	3000 (80,4)	3300 (88,4)	3800 (102)
		250 (17,2)	3400 (91,1)	3700 (99,2)	4200 (113)
		100 (6,9)	1500 (40,2)	2100 (56,3)	2500 (67,0)
		150 (10,3)	2400 (64,3)	2700 (72,4)	3200 (85,8)
110 (7,6)	200 (13,8)	2900 (77,7)	3100 (83,1)	3600 (96,5)	
	250 (17,2)	3200 (85,8)	3500 (93,8)	4000 (107)	
	120 (8,3)	1700 (45,6)	2400 (64,3)	2900 (77,7)	
	150 (10,3)	2500 (67,0)	2900 (77,7)	3400 (91,1)	
130 (9,0)	200 (13,8)	3000 (80,4)	3300 (88,4)	3800 (102)	
	250 (17,2)	3400 (91,1)	3700 (99,2)	4200 (113)	
	140 (9,7)	1900 (50,9)	2900 (77,7)	3400 (91,1)	
	150 (10,3)	3200 (85,8)	3500 (93,8)	4000 (107)	
150 (10,3)	200 (13,8)	3400 (91,1)	3700 (99,2)	4200 (113)	
	250 (17,2)	3600 (96,5)	3900 (105)	4400 (118)	
	160 (11,0)	2100 (56,3)	3300 (88,4)	3800 (102)	
	200 (13,8)	3500 (93,8)	3900 (105)	4400 (118)	
		250 (17,2)	3800 (102)	4100 (110)	4600 (123)

1. For capacities in SCFH of 0.6 specific gravity gas, multiply tabulated values by 1.29.

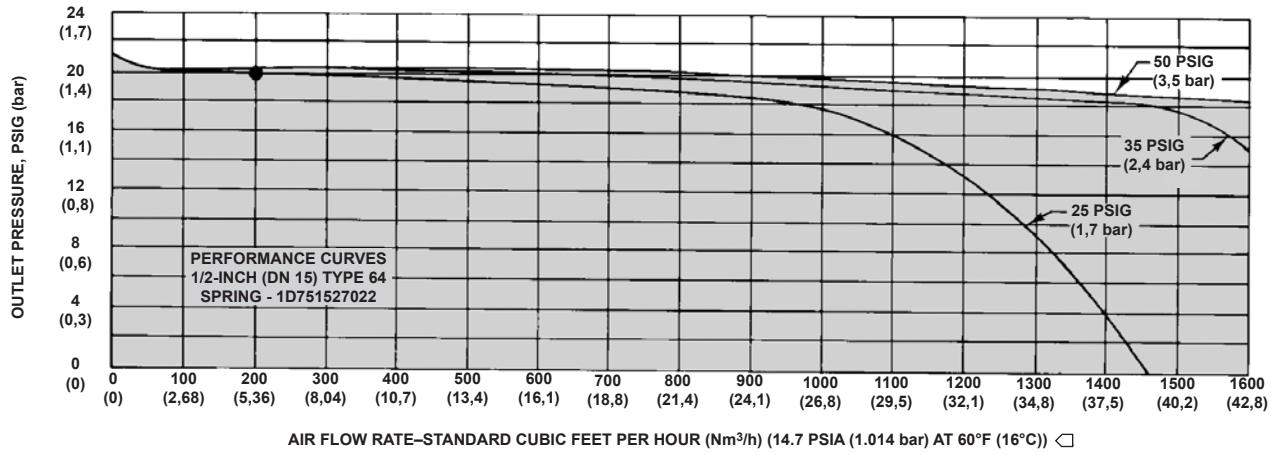

BE1388-E
B0393-2

◻ FOR CAPACITIES IN SCFH OF 0.6 SPECIFIC GRAVITY GAS, MULTIPLY FLOW RATE BY 1.29. TO CONVERT SCFH TO NORMAL CUBIC METERS PER HOUR (Nm³/h) AT 0°C AND 1.01325 bar (ABSOLUTE), MULTIPLY BY 0.0268.

● INITIAL SETTING POINT AT 20 PSIG (1.4 bar) AT 200 SCFH (5.66 Nm³/h) FLOW RATE WITH 100 PSIG (6.9 bar) INLET PRESSURES DENOTED ON EACH CURVE.

Figure 3. Typical 64 Series Performance Curves

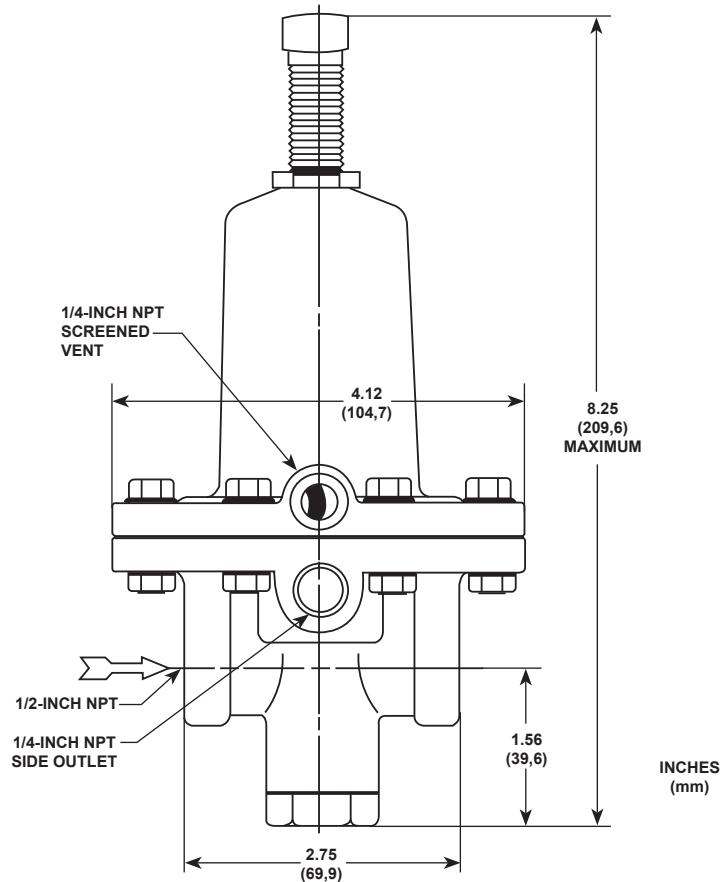

Figure 4. Dimensions

Ordering Information

Application Information

When ordering, specify:

1. Type of gas being controlled (air, ammonia, natural gas, nitrogen, etc.); list any factors such as impurities in the gas that may affect the compatibility of the gas with the regulator trim parts
2. Specific gravity of the gas
3. Temperature of the gas
4. Range of flowing inlet pressures to regulator
5. Outlet pressure setting or range
6. Flow rates
 - a. Minimum controlled flow
 - b. Normal flow
 - c. Maximum flow
7. Line size and end connection size of adjacent piping

Regulator Information

Refer to the Specifications section and carefully review the description to the right of each specification and specify your choice whenever a selection is offered. Always specify the type number as identified in the Available Configurations specification. For information on UL-listed constructions, consult your Fisher Sales Representative or Sales Office.

**Industrial Regulators
Regulator Division
Emerson Process Management**

USA - Headquarters
McKinney, Texas 75070 USA
Tel: 1-800-558-5853
Outside U.S. 1-972-548-3574

Asia-Pacific
Shanghai, China 201206
Tel: +86 21 2892 9000

Europe
Bologna, Italy 40013
Tel: +39 051 4190611

**Natural Gas Technologies
Regulator Division
Emerson Process Management**

USA - Headquarters
McKinney, Texas 75070
Tel: 1-800-558-5853
Outside U.S. 1-972-548-3574

Asia-Pacific
Singapore, Singapore 128461
Tel: +65 6777 8211

Europe
Bologna, Italy 40013
Tel: +39 051 4190611
Gallardon, France 28320
Tel: +33 (0)2 37 33 47 00

**TESCOM
Regulator Division
Emerson Process Management**

USA - Headquarters
Elk River, Minnesota 55330 USA
Tel: 1-763-241-3238

Europe
Selmsdorf, Germany 23923
Tel: +49 (0) 38823 31 0

For further information visit www.emersonprocess.com/regulators

The Emerson logo is a trademark and service mark of Emerson Electric Co. All other marks are the property of their prospective owners. Fisher is a mark owned by Fisher Controls, Inc., a business of Emerson Process Management.

The contents of this publication are presented for informational purposes only, and while every effort has been made to ensure their accuracy, they are not to be construed as warranties or guarantees, express or implied, regarding the products or services described herein or their use or applicability. We reserve the right to modify or improve the designs or specifications of such products at any time without notice.

Emerson Process Management does not assume responsibility for the selection, use or maintenance of any product. Responsibility for proper selection, use and maintenance of any Emerson Process Management product remains solely with the purchaser.