

## V4297A Solenoid Safety Shut-Off Valve

### PRODUCT DATA

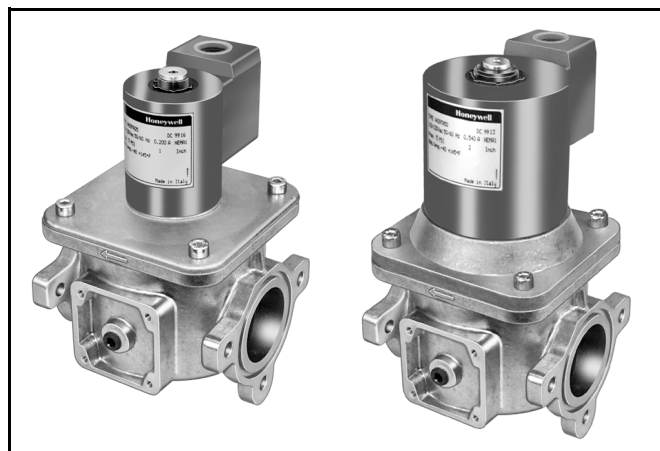

### APPLICATION

The V4297A controls gas flow to commercial and industrial burners. The valve is part of the Honeywell Integrated Valve Train System that allows gas train components to be directly bolted together.

### FEATURES

- Used with natural or liquefied petroleum (LP) gases.
- V4297A normally closed valves are rated for final shutoff service (safety shutoff).
- One valve body (small) applicable to five pipe sizes:
- 3/4 in. (19 mm), 1 in. (25 mm), 1-1/4 in. (32 mm), 1-1/2 in. (38 mm) and 2 in. (51 mm) pipes.
- Two valves with different capacities:
- V4297A1005: 1 in. (25 mm) internal opening (small capacity).
- V4297A1013: 2 in. (51 mm) internal opening (high capacity).
- Two 1/4 in. NPT upstream and one 1/4 in. NPT downstream pressure taps and plugs.
- Accepts C6097 Pressure Switch mounted directly to flange (upstream pressure tap only).
- NEMA 1 enclosure standard.
- Optional Visual Position Indicator available.
- Unpainted aluminum body.

### Contents

Application .....	1
Features .....	1
Specifications .....	2
Ordering Information .....	2
Installation .....	6
Wiring .....	6
Operation And Checkout .....	7
Troubleshooting .....	8
Service Information .....	8



# SPECIFICATIONS

**IMPORTANT**

The specifications in this publication do not include normal manufacturing tolerances; therefore, an individual unit may not exactly match the specifications listed. Also, this product is tested and calibrated under closely controlled conditions, and some minor differences in performance can be expected if those conditions are changed.

**Models:**

V4297A1005: small body, 1 in. (25 mm) internal opening (small capacity).

V4297A1013: small body, 2 in. (51 mm) internal opening (high capacity).

**Types of Gas:** Natural, manufactured, mixed or LP only.

**Gas Train Pipe Size:** 3/4 in. (19 mm), 1 in. (25 mm), 1-1/4 in. (32 mm), 1-1/2 in. (38 mm), 2 in. (51 mm).

**Operating Pressure Rating:** Maximum: 5 psi.

**Valve Capacities:** See Table 1.

**Table 1. Valve Flow Capacities.**

Valve Type	Pipe Diameter (in.)	Flow Capacity (cfh) <sup>a</sup>
Safety Shut-Off (large flow) V4297A1013	3/4	1190
	1	1460
	1-1/4	2260
	1-1/2	2735
	2	3060
Safety Shut-Off (small flow) V4297A1005	3/4	650
	1	700
	1-1/4	780

<sup>a</sup> Ratings at 1 in. (.025 kPa) pressure drop for gas with 0.64 sp gr.

**Flow Curves:** See Table 1 and Fig. 1 through 8.

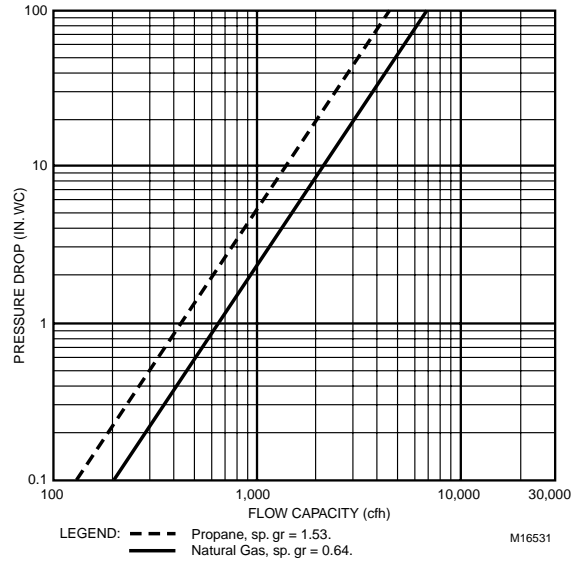

**Fig. 1. Flow curves for V4297A1005 SSOV with 3/4 in. (19 mm) pipe adapter.**

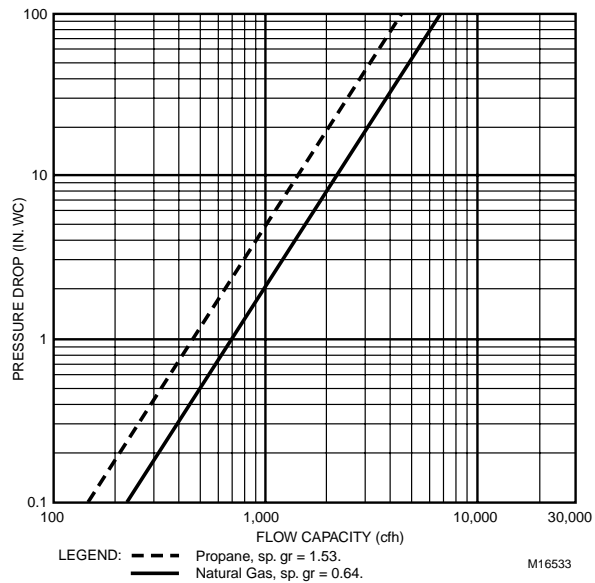

**Fig. 2. Flow curves for V4297A1005 SSOV with 1 in. (25 mm) pipe adapter.**

# ORDERING INFORMATION

When purchasing replacement and modernization products from your TRADELINE® wholesaler or distributor, refer to the TRADELINE® Catalog or price sheets for complete ordering number.

If you have additional questions, need further information, or would like to comment on our products or services, please write or phone:

1. Your local Home and Building Control Sales Office (check white pages of your phone directory).
2. Home and Building Control Customer Relations  
Honeywell, 1885 Douglas Drive North  
Minneapolis, Minnesota 55422-4386 (800) 328-5111

In Canada—Honeywell Limited/Honeywell Limitée, 35 Dynamic Drive, Scarborough, Ontario M1V 4Z9.

International Sales and Service Offices in all principal cities of the world. Manufacturing in Australia, Canada, Finland, France, Germany, Japan, Mexico, Netherlands, Spain, Taiwan, United Kingdom, U.S.A.

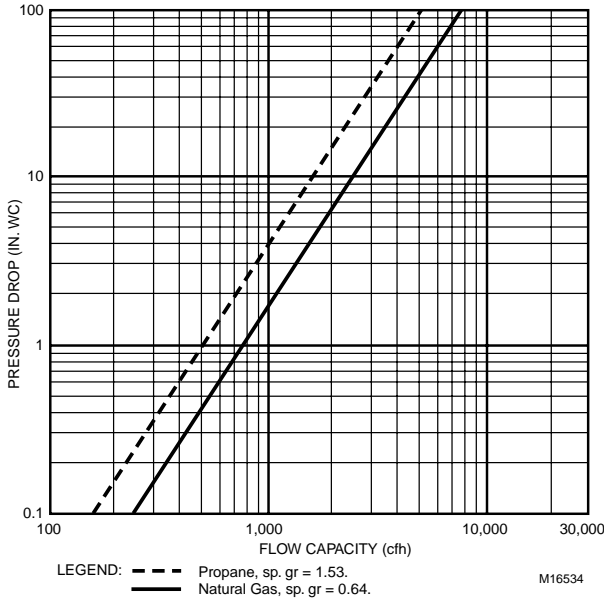

**Fig. 3. Flow curves for V4297A1005 SSOV with 1-1/4 in. (32 mm) pipe adapter**

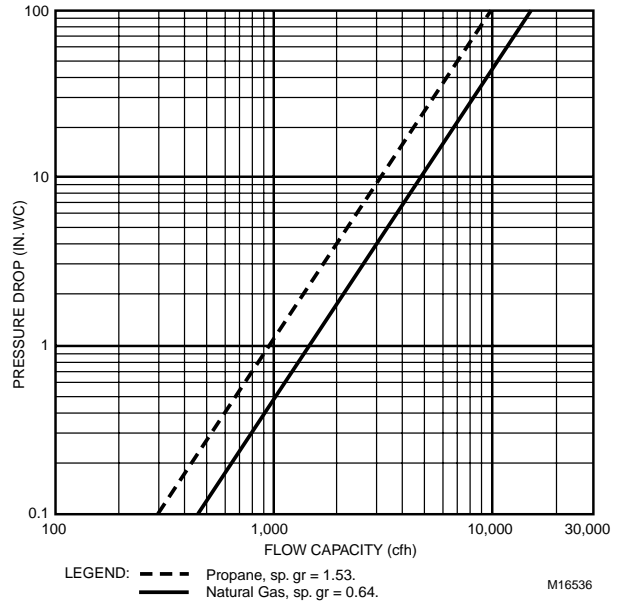

**Fig. 5. Flow curves for V4297A1013 SSOV with 1 in. (25 mm) pipe adapter.**

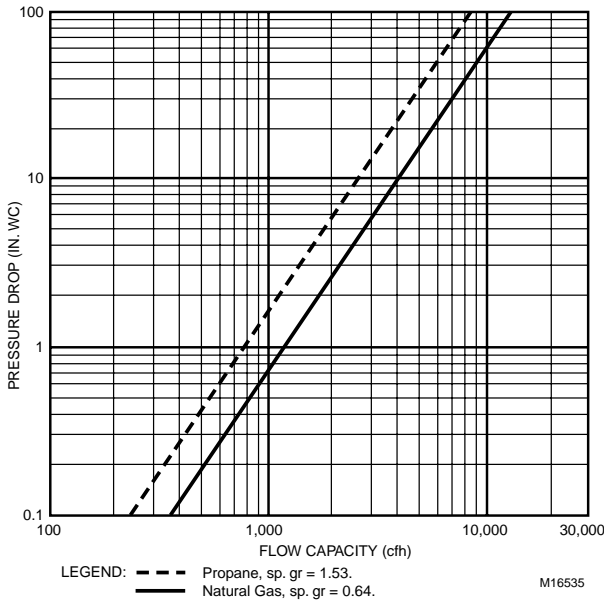

**Fig. 4. Flow curves for V4297A1013 SSOV with 3/4 in. (19mm) pipe adapter.**

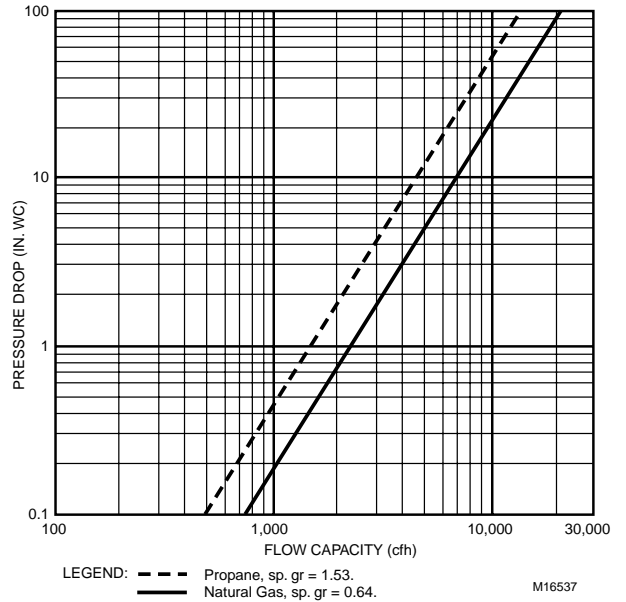

**Fig. 6. Flow curves for V4297A1013 SSOV with 1-1/4 in. (32 mm) pipe adapter.**

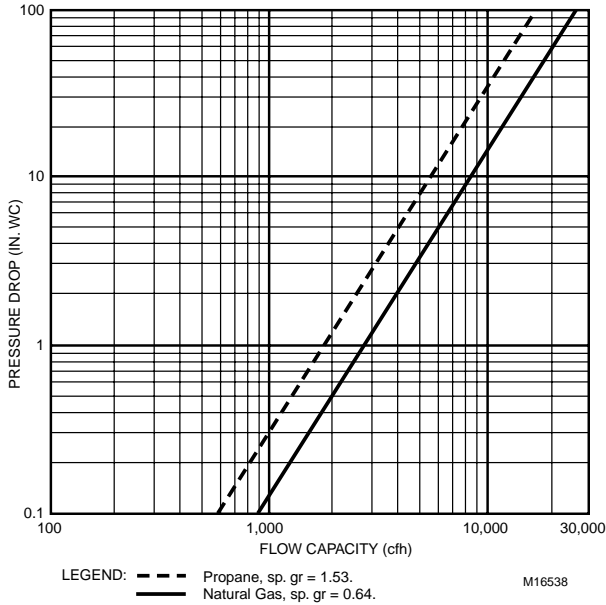

**Fig. 7. Flow curves for V4297A1013 SSOV with 1-1/2 in. (38 mm) pipe adapter.**

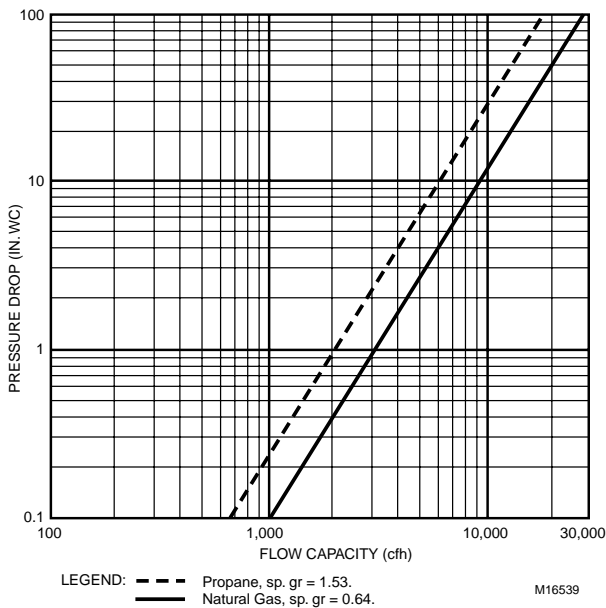

**Fig. 8. Flow curves for V4297A1013 SSOV with 2 in. (51 mm) pipe adapter.**

**Bolt/Nut Fasteners:** Small Body:  
 3/8-16 by 1-3/8, Grade 5 bolt. Metric equivalent:  
 M8 by 1.25 by 35 mm, Class 9.8.

**Tapping and Plug:**  
 Taps: 1/4 in. NPT taps. Plugs: 1/4 inch hex head.

**Ambient Operating Temperature Range:**  
 -40°F (-40°C) to +130°F (54°C).

**Valve Body Material:** Aluminum.

**Mounting:** Directly bolted to Integrated Valve Train components.

**Mounting Position:** Vertical to 90 degrees from vertical. See Fig. 9.

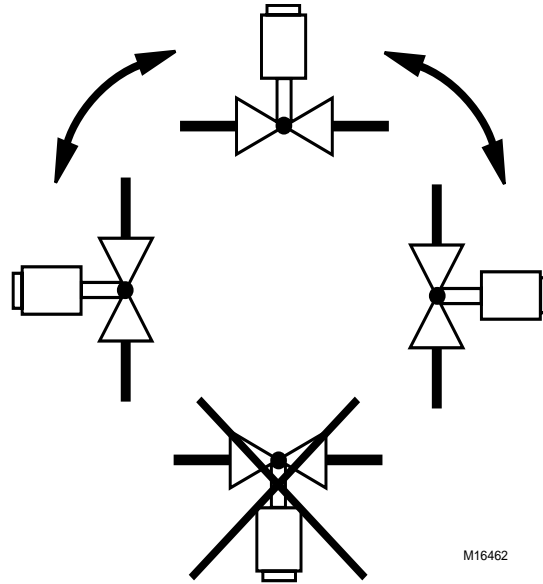

**Fig. 9. Mounting positions for V4297A Solenoid Shut-off Safety Valve.**

**Electrical Terminations:** Screw terminal connections.

**Current Draw:**  
 V4297A1005 small capacity, 120V: 0.2A.  
 V4297A1013 high capacity, 120V: 0.5A.

**Valve Opening Time:** < 1 sec.

**Valve Closing Time:** < 1 sec.

**Dimensions:** See Fig. 10 and 11.

**Weight:**  
 V4297A1005: 8 lb (3.6 kg)  
 V4297A1013: 14 lb (6.3 kg)

**Replacement Parts:**  
 BBA51315 Coil for V4297A1005.  
 BBA51318 Coil for V4297A1013.

**Accessories:**  
**Pipe Adapters:**  
 32000109-001 3/4 in. NPT.  
 32000109-002 1 in. NPT.  
 32000109-003 1-1/4 in. NPT.  
 32000109-004 1-1/2 in. NPT.  
 32000109-005 2 in. NPT.  
 KTCPI001 Visual Position Indicator.  
 4074EYF Bag Assembly (bolts, nuts and washers), supplied.  
 4074EYK Bag Assembly (O-rings and tube of lubricant), supplied.

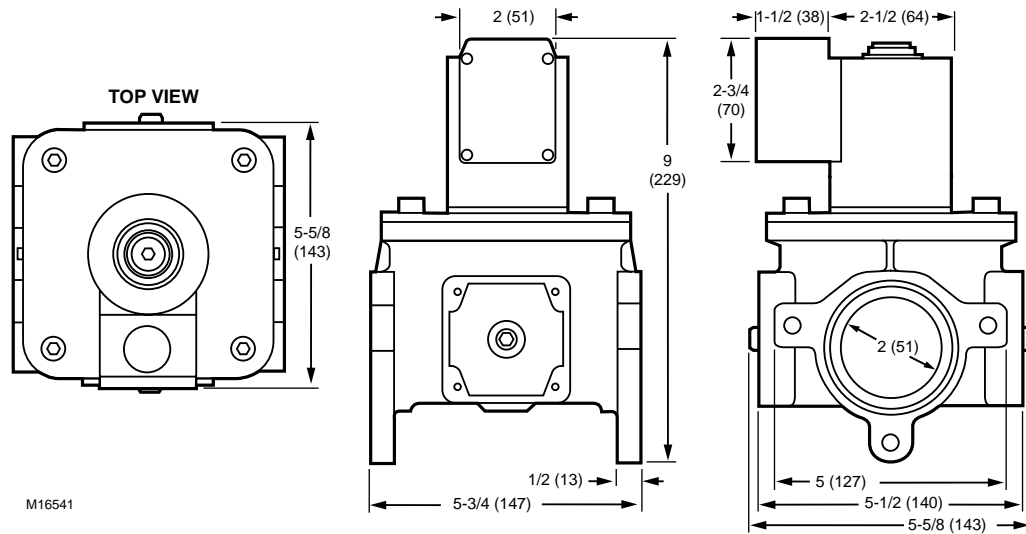

Fig. 10. Approximate dimensions of V4297A1005 SSOV in in. (mm).

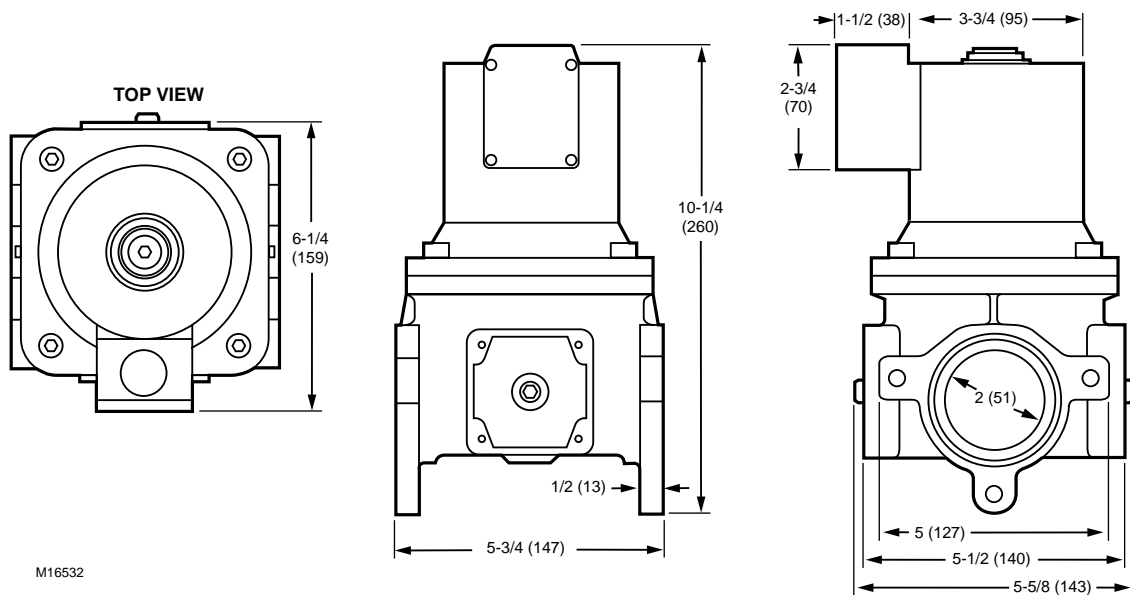

Fig. 11. Approximate dimensions of V4297A1013 SSOV in in. (mm).

**Approvals:**

Underwriters Laboratories Inc. (UL): Listed.  
 Industrial Risk Insurers (IRI), formerly FIA: Acceptable.  
 International Approval Services (IAS): Design Certified.  
 Factory Mutual (FM): Approved. (KTCPI001 Visual Position Indicator required if used with pipe size larger than 3/4 in.)

NOTE: NOTE: Some application codes, such as NFPA, require visual indication of the valve position as provided by the KTCPI001 Visual Position Indicator.

## INSTALLATION

### When Installing This Product...

1. Read these instructions carefully. Be sure to follow warning information carefully.
2. Check the ratings given in the instructions and on the product to make sure the product is suitable for your application.
3. Installer must be a trained, experienced flame safeguard control technician.
4. After installation is complete, check out product operation as provided in these instructions.

## ⚠ WARNING

**Explosion Hazard and Electrical Shock Hazard.**  
**Can cause explosion, serious injury or death.**  
 Turn off gas supply before beginning installation.

Disconnect power supply before beginning installation.  
 More than one disconnection may be involved.

### Mounting

Refer to the Integrated Valve Train Installation Instructions, form 66-1099, for instructions on mounting a V4297A in a Honeywell Integrated Valve Train System. Refer to the installation instructions packed with the Honeywell KTCPI001 Visual Position Indicator for mounting instructions of the indicator.

## WIRING

1. Make sure all wiring agrees with all applicable local codes, ordinances and regulations. An opening is provided to accommodate rigid conduit or armored cable for line voltage operation. See Fig. 12.
2. Check the power supply circuit to verify the voltage and frequency are correct for the valve.
3. See Fig. 13 for typical V4297A wiring with the RM7800 Burner Controller. Follow the burner manufacturer wiring diagram, when provided. Refer to the relay module wiring diagram for specific wiring terminal designations.
4. Make wiring connections at the electrical terminations provided in the valve wiring compartment.



Fig. 12. Wiring compartment of V4297A SSOV.

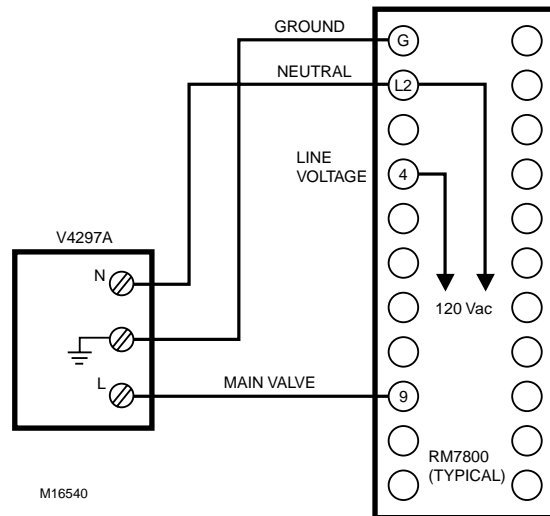

Fig. 13. Typical wiring diagram for V4297A SSOV.

## OPERATION AND CHECKOUT

### Operation

The V4297A Safety Shutoff Valve is a normally closed valve. The valve opens when it is energized and closes when the power is removed.

### **⚠️ WARNING**

**Explosion Hazard and Electrical Shock Hazard.  
Can cause explosion, serious injury or death.**

1. Do not put the system into service until you have satisfactorily completed the following Valve Leak Test, all applicable tests described in the Checkout section of the instructions for the flame safeguard control and any other tests required by the burner manufacturer.
2. All tests must be performed by a trained, experienced flame safeguard technician.
3. Close all manual fuel shutoff valves immediately if trouble occurs.

After the installation is complete, cycle the valve several times with the manual fuel shutoff cock closed. Make sure the valve functions properly. Also, perform the Valve Leak Test before putting the valve into service.

### Valve Leak Test (Fig. 14)

This is a test for checking the closure tightness of the gas safety shutoff valve. It should be performed only by trained, experienced flame safeguard control technicians during the initial startup of the burner system or whenever the valve is replaced (see Service Information section). It is recommended that this test also be included in the scheduled inspection and maintenance procedures. For a periodic inspection test, follow steps 1, 3, 4, 5, 8, 9, 10, 12, 13, 16 and 17.

1. De-energize the control system to make sure no power goes to the valve (C, Fig. 14).
2. Close the upstream manual gas cock (A).
3. Make sure the manual test petcock (F) is closed in the leak test tap assembly (D).
4. Remove the leak test tap plug and connect the test apparatus to the leak test tap (D).
5. Close the downstream manual gas cock (E).
6. Open the upstream manual gas cock (A).
7. Run the V4297A Valve to its open position (through the safety system); then immediately de-energize the system to close the V4297A Valve.
8. Immerse a 1/4 in. (6 mm) tube vertically 1/2 in. (13 mm) into a jar of water.
9. Slowly open the manual test petcock (F).
10. When the rate of bubbles coming through the water stabilizes, count the number of bubbles appearing during a ten-second period. Each bubble appearing represents a flow rate of 0.001 cfh.

### IMPORTANT

To meet U.S. requirements, make sure leakage does not exceed the rates in Table 2.

Table 2. Valve allowable leakage rate.

V4297A	Allowable leakage (cc/hr) <sup>a</sup>	Number of bubbles (per 10 sec.)
Low Capacity	235	8
High Capacity	470	16

<sup>a</sup> Based on air at standard conditions, test pressure provided by ANSI Z21.21, Section 2.42 and a maximum of 235 cc/h/in of seal-off diameter (not pipe size).

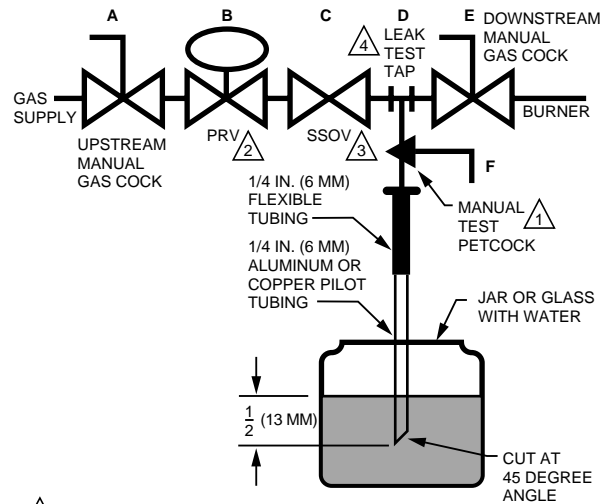

⚠️ 1 CAN ALSO BE A PERMANENT PETCOCK.

⚠️ 2 PRV = PRESSURE REGULATING VALVE.

⚠️ 3 SSOV = SAFETY SHUTOFF VALVE.

⚠️ 4 ONLY USE ONE OF THE DOWNSTREAM TAPS ON THE 550V. M9547D

Fig. 14. Valve leak test.

NOTE: NOTE: For international leak test requirements, contact the appropriate approval agency.

### After the Test

1. Close the upstream manual gas cock (A).
2. Close the manual test petcock (F), remove the test apparatus, and close the leak test tap (D).
3. Make sure the downstream manual gas cock (E) is closed.
4. Open the upstream manual gas cock (A) and energize the V4297A Valve through the safety system.
5. Test with rich soap and water solution to make sure there is no leak at the leak test tap (D) or any pipe adapter/valve mating surfaces.
6. De-energize the V4297A Valve (C).
7. Open the downstream manual gas cock (E).
8. Restore the system to normal operation. If two safety shutoff valves are used, check each valve separately for closure tightness.

## TROUBLESHOOTING

### WARNING

**Electrical Shock Hazard.**  
**Can cause serious injury or death.**

Use extreme caution while troubleshooting; line voltage is present.

#### **IMPORTANT**

*Do not replace the valve until all other sources of trouble are eliminated.*

### Troubleshooting Procedure

If the valve does not open when the thermostat or controller calls for heat:

1. Check for line voltage at the valve leadwires or terminal block.
2. If there is no voltage at the valve leadwires or terminal block, make sure:
  - a. line voltage power is connected to the master switch;
  - b. master switch is closed and overload protection (circuit breaker, fuse or similar device) has not opened the power line.
3. If there is still no voltage at the valve leadwires or terminal block, make sure all appropriate contacts in the thermostat or controller, limits and flame safeguard controls are closed. If one or more are open, determine the cause(s); correct the trouble, and proceed.
4. If there is proper voltage at the valve but the valve still does not open, check for normal gas pressure.
5. If the valve still does not open, replace the valve.

If the valve does not close when one or more of the appropriate contacts in the thermostat, controller, limits or flame safeguard control is open:

1. Make sure the valve is wired in the correct circuit.
2. Open the master switch to remove power from the valve.
3. If the valve closes now, check the wiring for the valve and correct the wiring as necessary.
4. Check for a short in the electrical circuit and repair it as necessary.

## SERVICE INFORMATION

### WARNING

**Explosion Hazard and Electrical Shock Hazard.**  
**Can cause explosion, serious injury or death.**

Turn off gas supply and disconnect all electrical power to the valve before servicing.

#### **IMPORTANT**

*Only trained, experienced flame safeguard control technicians should attempt to service or repair flame safeguard controls and burner assemblies.*

### Scheduled Inspection and Maintenance

Set up and follow a schedule for periodic inspection and maintenance, including the burner, all other controls and the valve(s). It is recommended that the valve leak test in the Checkout section be included in this schedule. Refer to the instructions for the primary safety control(s) for more inspection and maintenance information.

## Honeywell

#### **Home and Building Control**

Honeywell  
1985 Douglas Drive North  
Golden Valley, MN 55422

#### **Home and Building Control**

Honeywell Limited-Honeywell Limitée  
35 Dynamic Drive  
Scarborough, Ontario  
M1V 4Z9

#### **Honeywell Asia Pacific Inc.**

Room 3213-3225  
Sun Hung Kai Centre  
No. 30 Harbour Road  
Wanchai  
Hong Kong

#### **Honeywell Europe S.A.**

3 Avenue du Bourget  
1140 Brussels  
Belgium

#### **Honeywell Latin American Region**

480 Sawgrass Corporate Parkway  
Suite 200  
Sunrise FL 33325

