

Series 810: 2 Way Angle Body Valves: 1/4" to 3" NPT

On Off Control



FEATURES

- Compact design, high flow rates
- Visual position indicator standard
- For temperatures from – 22°F to +430°F / -30°C to 221°C
- Working pressures up to 580 psi
- Damped closing anti-water hammer design (fluid under seat)
- Metal actuator housing for exceptional durability in steam & mildly aggressive applications
- Valves satisfy the Pressure Equipment Directive 97/23/EC
- Mountable in any position
- Tight shut-off and Long Service Life
- Actuator and valve components fully repairable

Technical Specifications

Body Material	Bronze Rg5	AISI 316L	Brass
Function	2/2 NC, NO	2/2 NC, NO	2/2 NC, NO
Nominal sizes	1/2" - 2"	1/4" - 2 1/2"	2 1/2" and 3"
Connections:			
NPT thread standard	1/2" - 2"	1/4" - 2 1/2"	2 1/2" - 3"
BSP thread (ISO228/1)			
Tri Clamp			
Tube Ends			
Flanges ANSI 150			
Nominal Pressure	235 psi (16 bar)	580 psi (40 bar)	235 psi (16 bar)
Differential Pressure	See Specifications tables		
Pilot Pressure	up to 145 psi (10bar) reference graphs		
Actuator:	2" & 3" brass plated	2" & 3" brass plated ^ Stainless Actuator	5" aluminum anodized
Max. Fluid Temperature	-22°F (-30°C) up to 392°F (200°C) # to -40°F (-40°C) *Optional	-22°F (-30°C) up to 392°F (200°C) # to -40°F (-40°C) * Up to +430°F (221°C)	-22°F (-30°C) up to 392°F (200°C) # to -40°F (-40°C)
Ambient Temperature	-22°F (-30°C) up to +140°F (60°C)		
Seal Material	PTFE		
Packing Gland	PTFE / Graphite		
Viscosity of the Fluid	maximum 600 mm ² /s (600cSt, 80°E, 2700 SSU)		
Vacuum	maximum 0.0295 mercury (Hg)		
Working pressure for inverted packing for vacuum service	maximum 175 psi		
Leakage	ANSI Class VI shutoff		
Installation	Any position		
Optical Position Indicator	Standard all sizes		
Pilot Control Media	Air, neutral gas, water		
Fluids	Inert gases, hot water, oils, steam	Aggressive & corrosive fluids	Inert gases, hot water, oils, steam

Options

- Electrical position indicators
- Inductive proximity switches
- Mechanical limit switches
- Manual override
- Oil and Grease free version
- Ultra High Temp. (PEEK)
- Stroke limiter

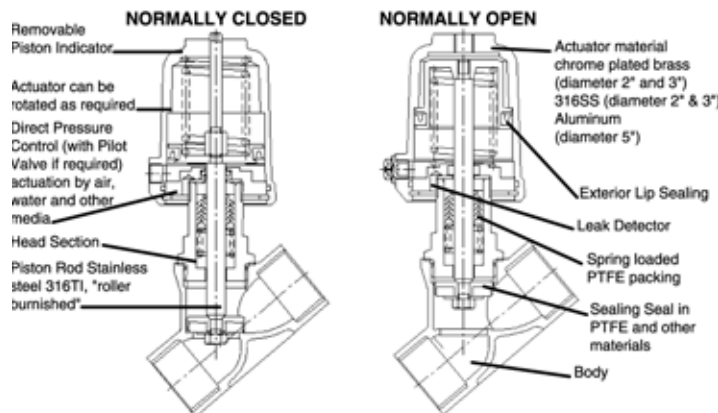



Series 810: 2 Way Angle Body Valves: 1/4" to 3" NPT

Series 810 Operating Data: Normally Closed, Flow Direction Under Seat Recommended for liquids and anti water-hammer application needs

On Off Control

BRONZE / BRASS * BODY VALVES

Port Size	Orifice Size		Flow Coeff		Min	Operating Pressure						Pilot Pressure		Actuator		Valve Number Bronze (1) (2)	Wt. lbs
	DN		Cv	Kv		psi	bar	psi	bar	psi	bar	psi	bar	mm	port		
	inch	(mm)	(m ³ /h)			air, gases	water, liquids	steam			dia	bsp					
1/2	0.59	15	4.1	3.6	0	232	16.0	232	16.0	-	-	51-145	3.5-10	50	1/8	810VBN08T320BH000	2.4
3/4	0.78	20	9.2	8.0	0	190	13.0	190	13.0	-	-	65-145	4.5-10	50	1/8	810VBN12T320BH000	2.6
3/4	0.78	20	9.2	8.0	0	232	16.0	232	16.0	-	-	85-145	5.7-10	50	1/8	810VBN12T323BH000	2.8
1	1.00	25	17.4	15.0	0	85	5.8	85	5.8	-	-	65-145	4.5-10	50	1/8	810VBN16T320BH000	3.1
1	1.00	25	17.4	15.0	0	130	9.0	130	9.0	-	-	85-145	5.7-10	50	1/8	810VBN16T323BH000	3.3
1	1.00	25	18.6	16.0	0	232	16.0	232	16.0	-	-	51-145	3.5-10	80	1/4	810VBN16T330BH000	6.6
1-1/4	1.25	32	24.3	21.0	0	75	5.2	75	5.2	-	-	85-145	5.7-10	50	1/8	810VBN20T320BH000	4.0
1-1/4	1.25	32	27.8	24.0	0	175	12.1	175	12.1	-	-	51-145	3.5-10	80	1/4	810VBN20T330BH000	7.3
1-1/4	1.25	32	27.8	24.0	0	232	16.0	232	16.0	-	-	65-145	4.5-10	80	1/4	810VBN20T332BH000	7.5
1-1/2	1.56	40	40.6	35.0	0	100	7.0	100	7.0	-	-	51-145	3.5-10	80	1/4	810VBN24T330BH000	8.0
1-1/2	1.56	40	40.6	35.0	0	145	10.0	145	10.0	-	-	65-145	4.5-10	80	1/4	810VBN24T332BH000	8.2
1-1/2	1.56	40	40.6	35.0	0	190	13.0	190	13.0	-	-	80-145	5.5-10	80	1/4	810VBN24T333BH000	8.5
1-1/2	1.56	40	40.6	35.0	0	220	15.2	220	15.2	-	-	30-145	2.1-10	125	1/4	810VBN24T350BH000	12.8
2	2.00	50	63.8	55.1	0	60	4.0	60	4.0	-	-	51-145	3.5-10	80	1/4	810VBN32T330BH000	9.2
2	2.00	50	63.8	55.1	0	110	7.6	110	7.6	-	-	80-145	5.5-10	80	1/4	810VBN32T333BH000	9.6
2	2.00	50	63.8	55.1	0	125	8.6	125	8.6	-	-	30-145	2.1-10	125	1/4	810VBN32T350BH000	14.1
2	2.00	50	63.8	55.1	0	190	13.0	190	13.0	-	-	45-145	3.1-10	125	1/4	810VBN32T353BH000	14.4
2-1/2	2.56	65	107.9	93.3	0	75	5.0	75	5.0	-	-	45-145	3.1-10	125	1/4	810VBN40T350BH000	18.5
3	3.15	80	133.4	115.0	0	50	3.5	50	3.5	-	-	45-145	3.1-10	125	1/4	810VBN48T350BH000	23.1

316L STAINLESS STEEL VALVES

Port Size	Orifice Size		Flow Coeff		Min	Operating Pressure						Pilot Pressure		Actuator		Valve Number Stainless (1) (2) (3) (4)	Wt. lbs
	DN		Cv	Kv		psi	bar	psi	bar	psi	bar	psi	bar	mm	port		
	inch	(mm)	(m ³ /h)			air, gases	water, liquids	steam			dia	bsp					
1/4	0.31	8	1.1	0.9	0	580	40.0	580	40.0	-	-	51-145	3.5-10	50	1/8	810VSN04T320BH000	2.2
3/8	0.39	10	1.9	1.6	0	580	40.0	580	40.0	-	-	51-145	3.5-10	50	1/8	810VSN06T320BH000	2.3
1/2	0.59	15	4.1	3.6	0	320	22.0	320	22.0	-	-	51-145	3.5-10	50	1/8	810VSN08T320BH000	2.4
3/4	0.78	20	9.2	8.0	0	190	13.0	190	13.0	-	-	65-145	4.5-10	50	1/8	810VSN12T320BH000	2.6
3/4	0.78	20	9.2	8.0	0	275	19.0	275	19.0	-	-	85-145	5.7-10	50	1/8	810VSN12T323BH000	2.8
1	1.00	25	17.4	15.0	0	85	5.8	85	5.8	-	-	65-145	4.5-10	50	1/8	810VSN16T320BH000	3.1
1	1.00	25	17.4	15.0	0	130	9.0	130	9.0	-	-	85-145	5.7-10	50	1/8	810VSN16T323BH000	3.3
1	1.00	25	18.6	16.0	0	320	22.0	320	22.0	-	-	51-145	3.5-10	80	1/4	810VSN16T330BH000	6.6
1-1/4	1.25	32	24.3	21.0	0	75	5.2	75	5.2	-	-	85-145	5.7-10	50	1/8	810VSN20T320BH000	4.0
1-1/4	1.25	32	27.8	24.0	0	175	12.1	175	12.1	-	-	51-145	3.5-10	80	1/4	810VSN20T330BH000	7.3
1-1/4	1.25	32	27.8	24.0	0	245	16.9	245	16.9	-	-	65-145	4.5-10	80	1/4	810VSN20T332BH000	7.5
1-1/4	1.25	32	27.8	24.0	0	320	22.0	320	22.0	-	-	85-145	5.7-10	80	1/4	810VSN20T333BH000	7.7
1-1/2	1.56	40	40.6	35.0	0	100	7.0	100	7.0	-	-	51-145	3.5-10	80	1/4	810VSN24T330BH000	7.9
1-1/2	1.56	40	40.6	35.0	0	145	10.0	145	10.0	-	-	65-145	4.5-10	80	1/4	810VSN24T332BH000	8.1
1-1/2	1.56	40	40.6	35.0	0	190	13.0	190	13.0	-	-	80-145	5.5-10	80	1/4	810VSN24T333BH000	8.3
1-1/2	1.56	40	40.6	35.0	0	220	15.2	220	15.2	-	-	30-145	2.1-10	125	1/4	810VSN24T350BH000	12.8
2	2.00	50	63.8	55.1	0	60	4.0	60	4.0	-	-	51-145	3.5-10	80	1/4	810VSN32T330BH000	9.2
2	2.00	50	63.8	55.1	0	110	7.6	110	7.6	-	-	80-145	5.5-10	80	1/4	810VSN32T333BH000	9.6
2	2.00	50	63.8	55.1	0	125	8.6	125	8.6	-	-	30-145	2.1-10	125	1/4	810VSN32T350BH000	14.1
2	2.00	50	63.8	55.1	0	190	13.0	190	13.0	-	-	45-145	3.1-10	125	1/4	810VSN32T353BH000	14.4
2-1/2	2.56	65	107.9	93.3	0	100	7.0	100	7.0	-	-	45-145	3.1-10	125	1/4	810VSN40T350BH000	18.5

Pressure ratings reflect standard product offering. Higher pressure ratings are available. Consult Parker.

- (1) Chrome Plated Brass Actuator Standard, Anodized Aluminum for 125mm housing
- (2) For BSP porting, change "N" to "G" in the 6th position
- (3) Optional Stainless Actuator, change "B" to "S" in the 13th position



Series 810: 2 Way Angle Body Valves: 1/4" to 3" NPT

On Off Control

Series 810 Operating Data: Normally Closed, Flow Direction Over Seat Recommended for steam and most gases

BRONZE / BRASS * BODY VALVES

Port Size	Orifice Size		Flow Coeff		Min	Operating Pressure						Pilot Pressure		Actuator		Valve Number Bronze (1) (2)	Wt. lbs
	inch	mm	Cv	Kv (m ³ /h)		psi air, gases	bar water, liquids	psi steam	bar steam	psi	bar	mm	port				
														dia	bsp		
1/2	0.59	15	4.1	3.6	0	232	16.0	-	-	210	14.5	40-145	2.8-10	50	1/8	810VBN08T120BH000	2.4
3/4	0.78	20	9.2	8.0	0	232	16.0	-	-	210	14.5	40-145	2.8-10	50	1/8	810VBN12T120BH000	2.6
1	1.00	25	17.4	15.0	0	232	16.0	-	-	210	14.5	40-145	2.8-10	50	1/8	810VBN16T120BH000	3.1
1-1/4	1.25	32	24.3	21.0	0	75	5.2	-	-	75	5.2	40-145	2.8-10	50	1/8	810VBN20T120BH000	4.0
1-1/4	1.25	32	27.8	24.0	0	232	16.0	-	-	210	14.5	16-145	1.1-10	80	1/4	810VBN20T130BH000	7.3
1-1/2	1.56	40	40.6	35.0	0	232	16.0	-	-	210	14.5	16-145	1.1-10	80	1/4	810VBN24T130BH000	7.9
2	2.00	50	63.8	55.1	0	203	14.0	-	-	203	14.0	16-145	1.1-10	80	1/4	810VBN32T130BH000	9.2
2-1/2	2.56	65	107.9	93.3	0	175	12.1	-	-	175	12.1	8-145	0.6-10	125	1/4	810VBN40T150BH000	* 18.5
3	3.15	80	133.4	115.0	0	131	9.0	-	-	131	9.0	8-145	0.6-10	125	1/4	810VBN48T150BH000	* 23.1

316L STAINLESS STEEL VALVES

Port Size	Orifice Size		Flow Coeff		Min	Operating Pressure						Pilot Pressure		Actuator		Valve Number Stainless (1) (2) (3) (4)	Wt. lbs
	inch	mm	Cv	Kv (m ³ /h)		psi air, gases	bar water, liquids	psi steam	bar steam	psi	bar	mm	port				
														dia	bsp		
1/4	0.31	8	1.1	0.9	0	580	40.0	-	-	210	14.5	40-145	2.8-10	50	1/8	810VSN04T120BH000	2.2
3/8	0.39	10	1.9	1.6	0	580	40.0	-	-	210	14.5	40-145	2.8-10	50	1/8	810VSN06T120BH000	2.3
1/2	0.59	15	4.1	3.6	0	580	40.0	-	-	210	14.5	40-145	2.8-10	50	1/8	810VSN08T120BH000	2.4
3/4	0.78	20	9.2	8.0	0	535	36.8	-	-	210	14.5	40-145	2.8-10	50	1/8	810VSN12T120BH000	2.6
1	1.00	25	17.4	15.0	0	290	20.0	-	-	210	14.5	40-145	2.8-10	50	1/8	810VSN16T120BH000	3.1
1	1.00	25	18.6	16.0	0	480	33.1	-	-	210	14.5	16-145	1.1-10	80	1/4	810VSN16T130BH000	6.6
1-1/4	1.25	32	24.3	21.0	0	160	11.0	-	-	160	11.0	40-145	2.8-10	50	1/8	810VSN20T120BH000	4.0
1-1/4	1.25	32	27.8	24.0	0	510	35.1	-	-	210	14.5	16-145	1.1-10	80	1/4	810VSN20T130BH000	7.3
1-1/2	1.56	40	40.6	35.0	0	335	23.1	-	-	210	14.5	16-145	1.1-10	80	1/4	810VSN24T130BH000	7.9
2	2.00	50	63.8	55.1	0	203	14.0	-	-	203	14.0	16-145	1.1-10	80	1/4	810VSN32T130BH000	9.2
2-1/2	2.56	65	107.9	93.3	0	175	12.1	-	-	175	12.1	8-145	0.6-10	125	1/4	810VSN40T150BH000	18.5

Pressure ratings reflect standard product offering. Higher pressure ratings are available. Consult Parker.

- (1) Chrome Plated Brass Actuator Standard, Anodized Aluminum for 125mm housing
- (2) For BSP porting, change "N" to "G" in the 6th position
- (3) Optional Stainless Actuator, change "B" to "S" in the 13th position
- (4) For ultra-high temperature 430°F, 1/2" to 1-1/4" sizes only, see Ultra High Temperature tables

Control Pressure & Operating Pressure Charts

Actuator Diameter 2" (50mm)

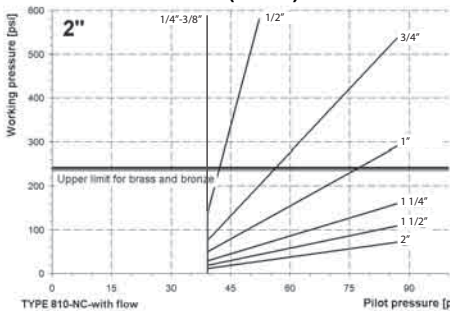

Actuator Diameter 3" (80mm)

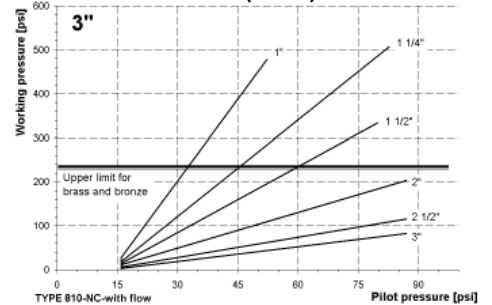

Actuator Diameter 5" (125mm)

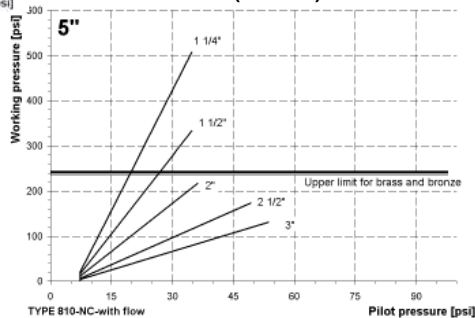



Series 810: 2 Way Angle Body Valves: 1/4" to 3" NPT

Series 810 Operating Data: Normally Open, Flow Direction Under Seat

On Off Control

BRONZE / BRASS * BODY VALVES

Port Size	Orifice Size		Flow Coeff		Operating Pressure			Pilot Pressure		Actuator		Valve Number Bronze (1) (2)	Wt. lbs
	DN		Cv	Kv	Min	psi bar	psi bar	psi bar	psi bar	mm	port		
	inch (mm)	(mm)	(m ³ /h)	(m ³ /h)		air, gases	water, liquids	steam			dia bsp		
1/2	0.59	15	4.1	3.6	0	232 16.0	232 16.0	210 14.5	35-145 2.4-10	50	1/8	810VBN08T220BH000	2.4
3/4	0.78	20	9.2	8.0	0	232 16.0	232 16.0	210 14.5	45-145 3.1-10	50	1/8	810VBN12T220BH000	2.6
1	1.00	25	17.4	15.0	0	160 11.0	160 11.0	160 11.0	50-145 3.5-10	50	1/8	810VBN16T220BH000	3.1
1	1.00	25	18.6	16.0	0	232 16.0	232 16.0	210 14.5	20-145 1.4-10	80	1/4	810VBN16T230BH000	6.6
1-1/4	1.25	32	24.3	21.0	0	100 7.0	100 7.0	100 7.0	50-145 3.5-10	50	1/8	810VBN20T220BH000	4.0
1-1/4	1.25	32	27.8	24.0	0	232 16.0	232 16.0	210 14.5	20-145 1.4-10	80	1/4	810VBN20T230BH000	7.3
1-1/2	1.56	40	40.6	35.0	0	232 16.0	232 16.0	210 14.5	20-145 1.4-10	80	1/4	810VBN24T230BH000	7.9
2	2.00	50	63.8	55.1	0	190 13.0	190 13.0	190 13.0	20-145 1.4-10	80	1/4	810VBN32T230BH000	9.2
2-1/2	2.56	65	107.9	93.3	0	175 12.1	175 12.1	175 12.1	10-145 0.7-10	125	1/4	810VBN40T250BH000 *	18.5
3	3.15	80	133.4	115.0	0	131 9.0	131 9.0	131 9.0	10-145 0.7-10	125	1/4	810VBN48T250BH000 *	23.1

316L STAINLESS STEEL VALVES

Port Size	Orifice Size		Flow Coeff		Operating Pressure			Pilot Pressure		Actuator		Valve Number Stainless (1) (2) (3) (4)	Wt. lbs
	DN		Cv	Kv	Min	psi bar	psi bar	psi bar	psi bar	mm	port		
	inch (mm)	(mm)	(m ³ /h)	(m ³ /h)		air, gases	water, liquids	steam			dia bsp		
1/4	0.31	8	1.1	0.9	0	580 40.0	580 40.0	210 14.5	35-145 2.4-10	50	1/8	810VSN04T220BH000	2.2
3/8	0.39	10	1.9	1.6	0	580 40.0	580 40.0	210 14.5	35-145 2.4-10	50	1/8	810VSN06T220BH000	2.3
1/2	0.59	15	4.1	3.6	0	580 40.0	580 40.0	210 14.5	35-145 2.4-10	50	1/8	810VSN08T220BH000	2.4
3/4	0.78	20	9.2	8.0	0	305 21.0	305 21.0	210 14.5	45-145 3.1-10	50	1/8	810VSN12T220BH000	2.6
1	1.00	25	17.4	15.0	0	160 11.0	160 11.0	160 11.0	50-145 3.5-10	50	1/8	810VSN16T220BH000	3.1
1	1.00	25	18.6	16.0	0	480 33.1	480 33.1	210 14.5	20-145 1.4-10	80	1/4	810VSN16T230BH000	6.6
1-1/4	1.25	32	24.3	21.0	0	100 7.0	100 7.0	100 7.0	50-145 3.5-10	50	1/8	810VSN20T220BH000	4.0
1-1/4	1.25	32	27.8	24.0	0	460 31.7	460 31.7	210 14.5	20-145 1.4-10	80	1/4	810VSN20T230BH000	7.3
1-1/2	1.56	40	40.6	35.0	0	305 21.0	305 21.0	210 14.5	20-145 1.4-10	80	1/4	810VSN24T230BH000	7.9
2	2.00	50	63.8	55.1	0	190 13.0	190 13.0	190 13.0	20-145 1.4-10	80	1/4	810VSN32T230BH000	9.2
2-1/2	2.56	65	107.9	93.3	0	175 12.1	175 12.1	175 12.1	10-145 0.7-10	125	1/4	810VSN40T250BH000	18.5

Pressure ratings reflect standard product offering. Higher pressure ratings are available. Consult Parker.

- (1) Chrome Plated Brass Actuator Standard, Anodized Aluminum for 125mm housing
- (2) For BSP porting, change "N" to "G" in the 6th position
- (3) Optional Stainless Actuator, change "B" to "S" in the 13th position
- (4) For ultra-high temperature 430°F, 1/2" to 1-1/4" sizes only, see Ultra High Temperature tables

Control Pressure & Operating Pressure Charts

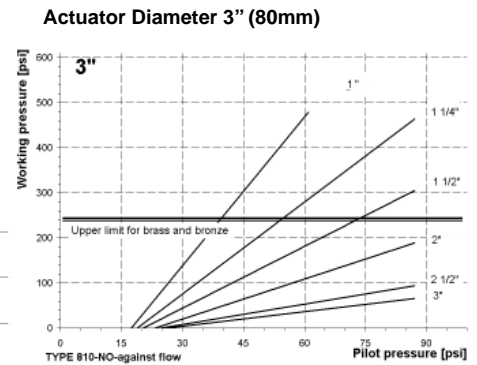
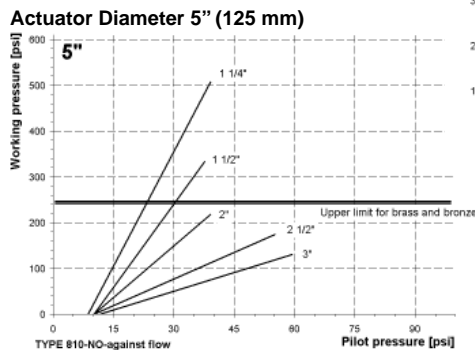
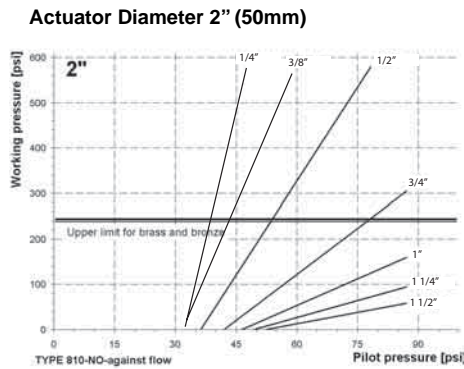



Series 810: 2 Way Angle Body Valves: 1/4" to 3" NPT

On Off Control

Series 810 Operating Data: Ultra High Temp., Normally Closed, Flow Direction Under Seat- For control of fluids up to 430° F / 221° C

316L STAINLESS STEEL VALVES

Port Size	Orifice Size		Flow Coeff		Operating Pressure					Pilot Pressure		Actuator		Valve Number Stainless (1) (2) (3) (4)	Wt. lbs		
	DN		Cv	Kv	Min	psi bar		psi bar		psi bar		mm	port				
	inch	(mm)	(m ³ /h)	air, gases		water, liquids	steam	psi	bar	psi	bar						
1/4	0.31	08	1.1	0.9	0	380	26.1	380	26.1	-	-	85-145	5.8-10	50	1/8	810VSN04P320BU000	2.6
1/2	0.59	15	4.1	3.6	0	380	26.1	380	26.1	-	-	85-145	5.8-10	50	1/8	810VSN08P320BU000	2.6
3/4	0.78	20	10.4	9.0	0	360	24.8	360	24.8	-	-	51-145	3.5-10	80	1/8	810VSN12P330BU000	4.2
1	1.00	25	19.7	17.1	0	250	17.2	250	17.2	-	-	51-145	3.5-10	80	1/4	810VSN16P330BU000	6.8
1-1/4	1.25	32	32.5	28.1	0	175	12.0	175	12.0	-	-	80-145	5.5-10	80	1/4	810VSN20P330BU000	7.5

Series 810 Operating Data: Ultra High Temp., Normally Closed, Flow Direction Over Seat- For control of fluids up to 430° F / 221° C

316L STAINLESS STEEL VALVES

Port Size	Orifice Size		Flow Coeff		Operating Pressure					Pilot Pressure		Actuator		Valve Number Stainless (1) (2) (3) (4)	Wt. lbs		
	DN		Cv	Kv	Min	psi bar		psi bar		psi bar		mm	port				
	inch	(mm)	(m ³ /h)	air, gases		water, liquids	steam	psi	bar	psi	bar						
1/4	0.31	08	1.1	0.9	0	580	40.0	-	-	330	22.7	65-145	4.5-10	50	1/8	810VSN04P120BU000	2.6
1/2	0.59	15	4.1	3.6	0	580	40.0	-	-	330	22.7	65-145	4.5-10	50	1/8	810VSN08P120BU000	2.6
3/4	0.78	20	10.4	9.0	0	360	24.8	-	-	330	22.7	65-145	4.5-10	50	1/8	810VSN12P120BU000	2.9
1	1.00	25	19.7	17.1	0	475	32.7	-	-	330	22.7	51-145	3.5-10	80	1/4	810VSN16P130BU000	6.8
1-1/4	1.25	32	32.5	28.1	0	360	24.8	-	-	330	22.7	51-145	3.5-10	80	1/4	810VSN20P130BU000	7.5

Pressure ratings reflect standard product offering. Higher pressure ratings are available. Consult Parker.

- (1) Chrome Plated Brass Actuator Standard, Anodized Aluminum for 125mm housing
- (2) For BSP porting, change "N" to "G" in the 6th position
- (3) Optional Stainless Actuator, change "B" to "S" in the 13th position
- (4) For ultra high temperature stainless valves, seal material changes from PTFE to PEEK.

Control Pressure & Operating Pressure Charts

Actuator Diameter 2" (50mm)

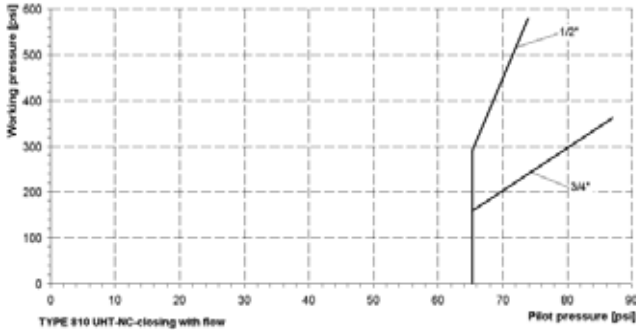

Actuator Diameter 3" (80mm)

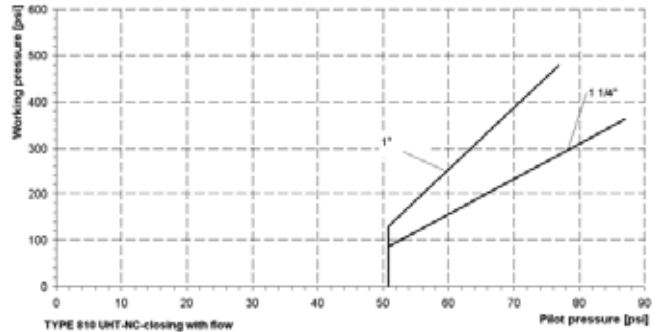

Actuator Diameter 5" (125 mm)

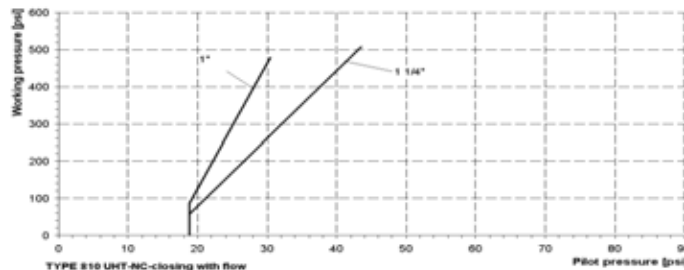



Series 810: 2 Way Angle Body Valves: 1/4" to 3" NPT

Series 810 Operating Data: Dimensions and Weights

On Off Control

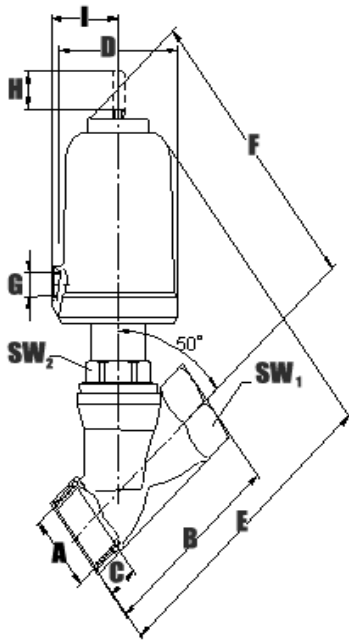

Normally Closed

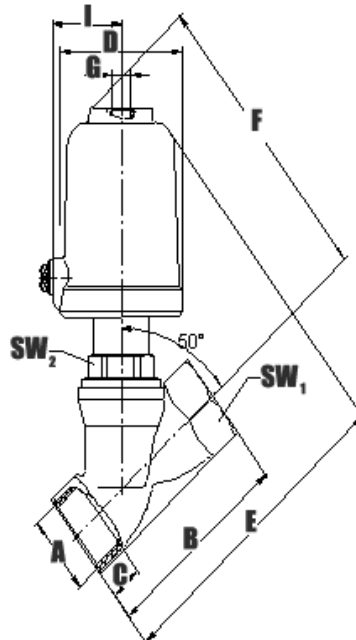

Normally Open

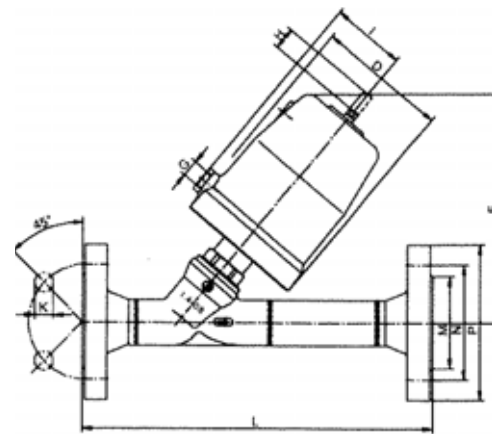

Flanged Version

A Pipe Size NPT	Actuator Diameter mm	DN	B		C	D	E		F	G	H	I	SW1		SW2		Cv-values		Weight	
			Bronze	Brass			Bronze	Brass					Bronze	Brass	Bronze	Brass	Bronze	Brass	lbs.	Kg.
1/4"	50	08	2.35	-	0.45	2.45	5.10	-	4.85	G1/8	0.33	1.35	0.80	-	1.20	1.1	-	2.2	1.0	
3/8"	50	10	2.35	-	0.45	2.45	5.10	-	4.85	G1/8	0.35	1.35	0.90	-	1.20	1.9	-	2.3	1.0	
1/2"	50	15	2.55	-	0.60	2.45	5.30	-	4.70	G1/8	0.28	1.35	1.00	-	1.20	4.1	-	2.4	1.1	
3/4"	50	20	2.95	-	0.65	2.45	5.30	-	4.90	G1/8	0.47	1.35	1.20	-	1.20	9.2	-	2.6	1.2	
1"	50	25	3.55	-	0.75	2.45	5.70	-	5.10	G1/8	0.63	1.35	1.55	-	1.20	17.3	-	3.1	1.4	
1"	80	25	3.55	-	0.75	3.80	7.30	-	6.70	G1/4	0.63	2.15	1.55	-	1.20	18.5	-	6.6	3.0	
1-1/4"	50	32	4.35	-	0.85	2.45	6.30	-	5.70	G1/8	0.63	1.35	1.90	-	1.20	24.3	-	4.0	1.8	
1-1/4"	80	32	4.35	-	0.85	3.80	7.85	-	7.50	G1/4	0.79	2.15	1.90	-	1.20	27.7	-	7.3	3.3	
1-1/4"	125	32	4.35	-	0.85	5.75	9.05	-	8.45	G1/4	0.79	3.15	1.90	-	1.20	28.0	-	12.1	5.5	
1-1/2"	50	40	4.70	-	0.85	2.45	6.50	-	5.90	G1/8	0.63	1.35	2.15	-	1.20	35.0	-	4.6	2.1	
1-1/2"	80	40	4.70	-	0.85	3.80	8.05	-	7.70	G1/4	0.91	2.15	2.15	-	1.20	40.4	-	7.9	3.6	
1-1/2"	125	40	4.70	-	0.85	5.75	9.25	-	8.65	G1/4	0.91	3.15	2.15	-	1.20	40.4	-	12.8	5.8	
2"	50	50	5.90	-	1.00	2.45	7.30	-	6.30	G1/8	0.63	1.35	2.70	-	1.25	46.0	-	5.9	2.7	
2"	80	50	5.90	-	1.00	3.80	8.85	-	7.85	G1/4	1.14	2.15	2.70	-	1.25	63.5	-	9.2	4.2	
2"	125	50	5.90	-	1.00	5.75	9.85	-	8.85	G1/4	1.14	3.15	2.70	-	1.25	63.5	-	14.1	6.4	
2-1/2"	80	65	-	7.10	1.20	3.80	-	10.25	8.25	G1/4	1.14	2.15	-	3.35	1.60	-	107	13.6	6.2	
2-1/2"	125	65	-	7.10	1.20	5.75	-	11.20	9.45	G1/4	1.14	3.15	-	3.35	1.60	-	107	18.5	8.4	
3"	80	80	-	8.25	1.30	3.80	-	11.00	8.85	G1/4	1.14	2.15	-	3.95	1.60	-	133	18.3	8.3	
3"	125	80	-	8.25	1.30	5.75	-	12.00	9.85	G1/4	1.14	3.15	-	3.95	1.60	-	133	23.1	10.5	

Dimension in inches except as noted

Dimension and Weights for High Temperature

A Pipe Size NPT	Actuator Diameter mm	DN	B		C	D	E		F	G	H	I	SW1	SW2	Cv-values	Weight	
			SST	Brass			SST	Brass								lbs.	Kg.
1/4"	50	08	2.35	0.45	2.45	5.10	5.60	G1/8	0.33	1.35	0.80	1.20	1.1	2.2	1.0		
1/2"	50	15	2.55	0.60	2.45	5.30	5.47	G1/8	0.28	1.35	1.00	1.20	4.1	2.6	1.2		
3/4"	50	20	2.95	0.65	2.45	5.30	5.67	G1/8	0.47	1.35	1.20	1.20	9.3	2.9	1.3		
3/4"	80	20	2.95	0.65	3.80	7.30	7.13	G1/4	0.47	1.35	1.20	1.20	9.3	4.2	1.9		
1"	50	25	3.55	0.75	2.45	5.70	7.28	G1/8	0.63	1.35	1.55	1.20	17.4	6.8	3.1		
1"	80	25	3.55	0.75	3.80	7.30	8.47	G1/4	0.63	2.15	1.55	1.20	18.6	11.7	5.3		
1-1/4"	80	32	4.35	0.85	3.80	7.85	7.92	G1/4	0.79	2.15	1.90	1.20	24.4	7.5	5.4		
1-1/4"	125	32	4.35	0.85	5.75	9.05	9.10	G1/4	0.79	3.15	1.90	1.20	27.8	12.3	5.6		

Dimension in inches except as noted

Dimension and Weights for Flanged

A Pipe Size NPT	Actuator Diameter mm	DN	M	N	P	F	K	L	D No. of drillings	Weight	
										lbs.	Kg.
1/2"	50	15	2.38	3.50	2.45	4.90	0.55	9.05	4	6.0	2.7
3/4"	50	20	2.75	3.88	2.45	4.90	0.55	10.25	4	7.5	3.4
1"	50	25	3.12	4.25	2.45	5.10	0.55	10.25	4	9.0	4.1
1"	80	25	3.12	4.25	3.80	6.70	0.55	10.25	4	12.6	5.7
1-1/4"	50	32	3.50	4.62	2.45	5.70	0.70	11.80	4	12.6	5.7
1-1/4"	80	32	3.50	4.62	3.80	7.30	0.70	11.80	4	15.9	7.2
1-1/4"	125	32	3.50	4.62	5.75	8.45	0.70	11.80	4	20.7	9.4
1-1/2"	50	40	3.88	5.00	2.45	5.90	0.70	11.80	4	14.1	6.4
1-1/2"	80	40	3.88	5.00	3.80	7.50	0.70	11.80	4	17.4	7.9
1-1/2"	125	40	3.88	5.00	5.75	8.65	0.70	11.80	4	22.1	10.0
2"	50	50	4.75	6.00	2.45	6.30	0.70	13.80	4	19.0	8.6
2"	80	50	4.75	6.00	3.80	7.70	0.70	13.80	4	22.3	10.1
2"	125	50	4.75	6.00	5.75	8.85	0.70	13.80	4	27.6	12.5

Dimension in inches except as noted

Series 810: 2 Way Angle Body Valves: 1/4" to 3" NPT

On Off Control

Series 810 Typical Cross Section Drawing

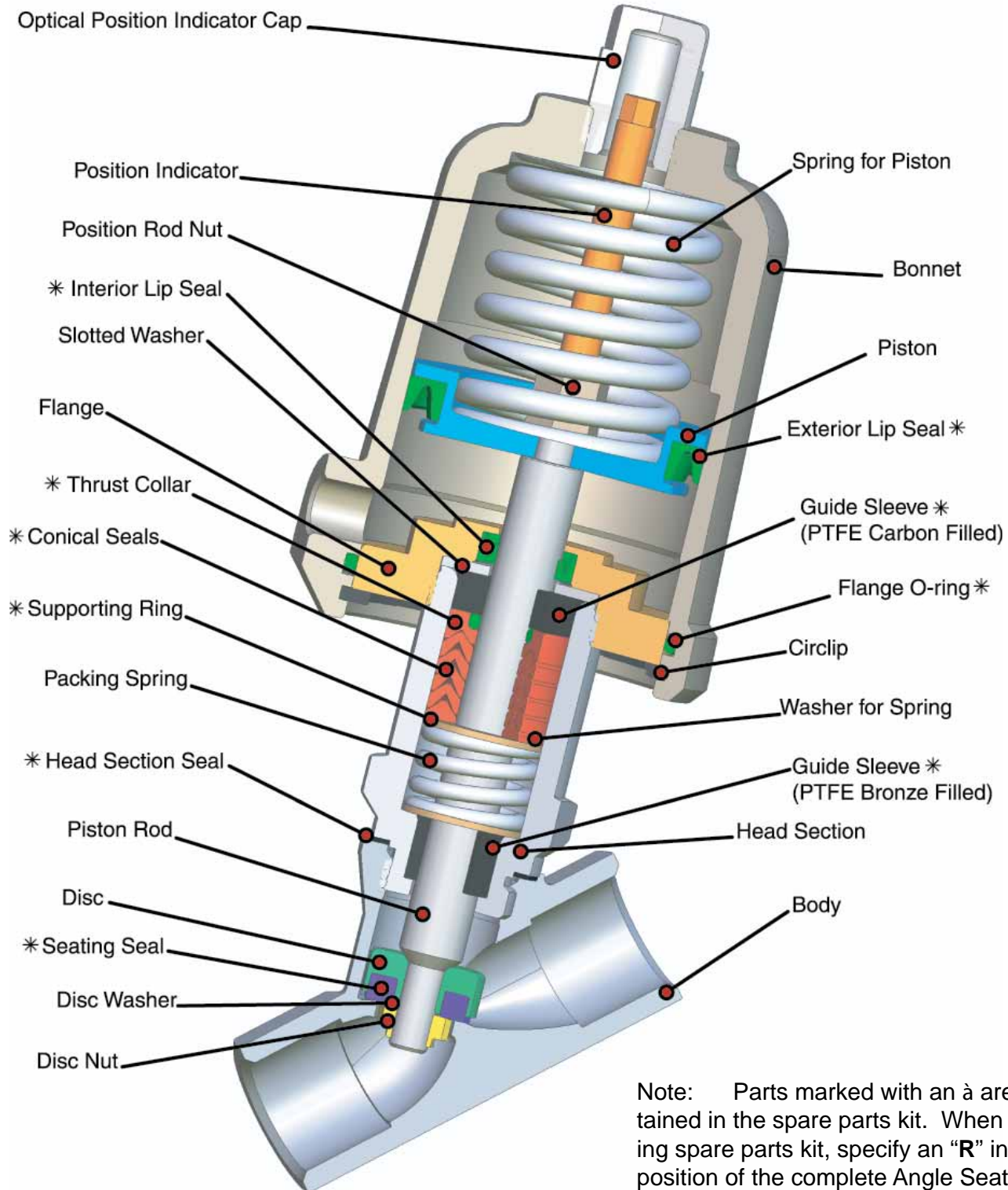

Note: Parts marked with an * are contained in the spare parts kit. When ordering spare parts kit, specify an "R" in the 4th position of the complete Angle Seat Valve Model Number.

Series 880: 3 Way Angle Body Valves: 1/2" to 1-1/2" NPT

On Off Control



FEATURES

- Working pressures up to 232 psi
- Visual position indicator
- Compact design
- Temperatures from -22°F to 392°F
- Mountable in any position
- Tight shut-off and long service life
- Versatile actuator options
- Actuator and valve components fully repairable

Technical Specifications

Body Material	Bronze Rg5	AISI 316L
Functions	Distributing, Mixing, Normally Closed, Normally Open	Distributing, Mixing, Normally Open
Nominal sizes	1/2" - 1-1/2 "	1/2" - 1-1/2 "
Connections: NPT thread standard BSP thread (ISO228/1)	1/2" - 1-1/2 "	1/2" - 1-1/2 "
Differential Pressure	See Specifications tables	See Specifications tables
Pilot Pressure	up to 145 psi (10bar) reference graphs	up to 145 psi (10bar) reference graphs
Actuator:	2" & 3" brass plated, 5" aluminum anodized	2" & 3" brass plated, 5" aluminum anodized
Max. fluid temperature	-22°F (-30°C) up to 392°F (200°C)	-22°F (-30°C) up to 392°F (200°C)
Max. ambient temperature	-22°F (-30°C) up to 140°F (60°C)	-22°F (-30°C) up to 140°F (60°C)
Seal Material	PTFE	PTFE
Packing Gland	PTFE / Graphite	PTFE / Graphite
Viscosity of the fluid	max.600 mm ² /s (600cSt, 80°E, 2700SSU)	max.600 mm ² /s (600cSt, 80°E, 2700SSU)
Vacuum	maximum 0.0295 mercury (Hg)	maximum 0.0295 mercury (Hg)
Working pressure for inverted packing for vacuum service	maximum 175 psi	maximum 175 psi
Leakage	ANSI Class VI shutoff	ANSI Class VI shutoff
Installation	Any position	Any position
Pilot Control Media	Air, neutral gas, water	Air, neutral gas, water
Fluids	Inert gases, hot water, oils, & slightly aggressive fluids	Inert gases, hot water, oils, & aggressive fluids
Optical Position Indicator	Standard	Standard

Options

- Electrical position indicators
 - Inductive proximity switches
 - Mechanical limit switches
- Manual override



Series 880: 3 Way Angle Body Valves: 1/2" to 1-1/2" NPT

Bronze Valve Operating Data

On Off Control

BRONZE BODY VALVES					DISTRIBUTING VALVE DATA (pilot option #3)												
Port Size	Orifice Size		Flow Coeff		Min	Operating Pressure			Pilot Pressure		Actuator		Valve Number Bronze (1)	Wt. lbs			
	inch	DN (mm)	Cv	Kv (m ³ /h)		psi air, gases	bar water, liquids	psi bar steam	psi	bar	mm dia	port bsp					
1/2	0.59	15	6.1	5.3	0	80	5.5	80	5.5	-	-	45-145	3.1-10	50	1/8	880VBN08T320BH000	3.3
1/2	0.59	15	6.1	5.3	0	232	16.0	232	16.0	-	-	35-145	2.4-10	80	1/4	880VBN08T330BH000	6.8
3/4	0.78	20	8.5	7.4	0	80	5.5	80	5.5	-	-	45-145	3.1-10	50	1/8	880VBN12T320BH000	3.3
3/4	0.78	20	8.5	7.4	0	232	16.0	232	16.0	-	-	35-145	2.4-10	80	1/4	880VBN12T330BH000	6.8
1	1.00	25	14.3	12.4	0	48	3.3	48	3.3	-	-	50-145	3.5-10	50	1/8	880VBN16T320BH000	4.2
1	1.00	25	14.3	12.4	0	160	11.0	160	11.0	-	-	35-145	2.4-10	80	1/4	880VBN16T330BH000	7.7
1	1.00	25	14.3	12.4	0	232	16.0	232	16.0	-	-	25-145	1.7-10	125	1/4	880VBN16T350BH000	12.3
1-1/4	1.25	32	23.2	20.2	0	58	4.0	58	4.0	-	-	45-145	3.1-10	80	1/4	880VBN20T330BH000	10.6
1-1/4	1.25	32	23.2	20.2	0	160	11.0	160	11.0	-	-	32-145	2.2-10	125	1/4	880VBN20T350BH000	14.8
1-1/2	1.56	40	26.7	23.2	0	58	4.0	58	4.0	-	-	45-145	3.1-10	80	1/4	880VBN24T330BH000	10.6
1-1/2	1.56	40	26.7	23.2	0	160	11.0	160	11.0	-	-	32-145	2.2-10	125	1/4	880VBN24T350BH000	14.8

BRONZE BODY VALVES					MIXING VALVE DATA (pilot option #4)												
Port Size	Orifice Size		Flow Coeff		Min	Operating Pressure			Pilot Pressure		Actuator		Valve Number Bronze (1)	Wt. lbs			
	inch	DN (mm)	Cv	Kv (m ³ /h)		psi air, gases	bar water, liquids	psi bar steam	psi	bar	mm dia	port bsp					
1/2	0.59	15	6.1	5.3	0	50	3.4	50	3.4	-	-	65-145	4.5-10	50	1/8	880VBN08T420BH000	3.3
1/2	0.59	15	6.1	5.3	0	232	16.0	232	16.0	-	-	60-145	4.2-10	80	1/4	880VBN08T430BH000	6.8
3/4	0.78	20	8.5	7.4	0	50	3.4	50	3.4	-	-	65-145	4.5-10	50	1/8	880VBN12T420BH000	3.3
3/4	0.78	20	8.5	7.4	0	232	16.0	232	16.0	-	-	60-145	4.2-10	80	1/4	880VBN12T430BH000	6.8
1	1.00	25	14.3	12.4	0	20	1.4	20	1.4	-	-	65-145	4.5-10	50	1/8	880VBN16T420BH000	4.2
1	1.00	25	14.3	12.4	0	140	9.6	140	9.6	-	-	65-145	4.5-10	80	1/4	880VBN16T430BH000	7.7
1	1.00	25	14.3	12.4	0	232	16.0	232	16.0	-	-	45-145	3.1-10	125	1/4	880VBN16T450BH000	12.3
1-1/4	1.25	32	23.2	20.2	0	60	4.1	60	4.1	-	-	75-145	5.2-10	80	1/4	880VBN20T430BH000	10.6
1-1/4	1.25	32	23.2	20.2	0	131	9.0	131	9.0	-	-	50-145	3.5-10	125	1/4	880VBN20T450BH000	14.8
1-1/2	1.56	40	26.7	23.2	0	60	4.1	60	4.1	-	-	75-145	5.2-10	80	1/4	880VBN24T430BH000	10.6
1-1/2	1.56	40	26.7	23.2	0	131	9.0	131	9.0	-	-	50-145	3.5-10	125	1/4	880VBN24T450BH000	14.8

BRONZE BODY VALVES					NORMALLY CLOSED VALVE DATA (pilot option #5)												
Port Size	Orifice Size		Flow Coeff		Min	Operating Pressure			Pilot Pressure		Actuator		Valve Number Bronze (1)	Wt. lbs			
	inch	DN (mm)	Cv	Kv (m ³ /h)		psi air, gases	bar water, liquids	psi bar steam	psi	bar	mm dia	port bsp					
1/2	0.59	15	6.1	5.3	0	232	16.0	232	16.0	-	-	42-145	2.9-10	50	1/8	880VBN08T520BH000	3.3
3/4	0.78	20	8.5	7.4	0	232	16.0	232	16.0	-	-	42-145	2.9-10	50	1/8	880VBN12T520BH000	3.3
1	1.00	25	14.3	12.4	0	175	12.1	175	12.1	-	-	45-145	3.1-10	50	1/8	880VBN16T520BH000	4.2
1	1.00	25	14.3	12.4	0	232	16.0	232	16.0	-	-	18-145	1.3-10	80	1/4	880VBN16T530BH000	7.7
1-1/4	1.25	32	23.2	20.2	0	220	15.2	220	15.2	-	-	18-145	1.3-10	80	1/4	880VBN20T530BH000	10.6
1-1/4	1.25	32	23.2	20.2	0	232	16.0	232	16.0	-	-	6-145	0.4-10	125	1/4	880VBN20T550BH000	14.8
1-1/2	1.56	40	26.7	23.2	0	220	15.2	220	15.2	-	-	18-145	1.3-10	80	1/4	880VBN24T530BH000	10.6
1-1/2	1.56	40	26.7	23.2	0	232	16.0	232	16.0	-	-	6-145	0.4-10	125	1/4	880VBN24T550BH000	14.8

BRONZE BODY VALVES					NORMALLY OPEN VALVE DATA (pilot option #6)												
Port Size	Orifice Size		Flow Coeff		Min	Operating Pressure			Pilot Pressure		Actuator		Valve Number Bronze (1)	Wt. lbs			
	inch	DN (mm)	Cv	Kv (m ³ /h)		psi air, gases	bar water, liquids	psi bar steam	psi	bar	mm dia	port bsp					
1/2	0.59	15	6.1	5.3	0	175	12.1	175	12.1	-	-	44-145	3.0-10	50	1/8	880VBN08T620BH000	3.3
1/2	0.59	15	6.1	5.3	0	232	16.0	232	16.0	-	-	18-145	1.3-10	80	1/4	880VBN08T630BH000	6.8
3/4	0.78	20	8.5	7.4	0	175	12.1	175	12.1	-	-	44-145	3.0-10	50	1/8	880VBN12T620BH000	3.3
3/4	0.78	20	8.5	7.4	0	232	16.0	232	16.0	-	-	18-145	1.3-10	80	1/4	880VBN12T630BH000	6.8
1	1.00	25	14.3	12.4	0	105	7.2	105	7.2	-	-	45-145	3.1-10	50	1/8	880VBN16T620BH000	4.2
1	1.00	25	14.3	12.4	0	232	16.0	232	16.0	-	-	18-145	1.3-10	80	1/4	880VBN16T630BH000	7.7
1-1/4	1.25	32	23.2	20.2	0	185	12.7	185	12.7	-	-	22-145	1.5-10	80	1/4	880VBN20T630BH000	10.6
1-1/4	1.25	32	23.2	20.2	0	232	16.0	232	16.0	-	-	8-145	0.6-10	125	1/4	880VBN20T650BH000	14.8
1-1/2	1.56	40	26.7	23.2	0	185	12.7	185	12.7	-	-	22-145	1.5-10	80	1/4	880VBN24T630BH000	10.6
1-1/2	1.56	40	26.7	23.2	0	232	16.0	232	16.0	-	-	8-145	0.6-10	125	1/4	880VBN24T650BH000	14.8

(1) Chrome Plated Brass Actuator Standard, Anodized Aluminum for 125mm housing



Series 880: 3 Way Angle Body Valves: 1/2" to 1-1/2" NPT

Stainless Steel Valve Operating Data

On Off Control

316 STAINLESS BODY VALVES										DISTRIBUTING VALVE DATA (pilot option #3)							
Port Size	Orifice Size		Flow Coeff		Min	Operating Pressure			Pilot Pressure		Actuator		Valve Number Stainless (1)	Wt. lbs			
	inch	DN (mm)	Cv	Kv (m ³ /h)		psi air, gases	bar water, liquids	psi bar steam	psi	bar	mm dia	port bsp					
1/2	0.59	15	6.1	5.3	0	130	9.0	130	9.0	-	-	55-145	3.8-10	50	1/8	880VSN08T320BH000	3.3
1/2	0.59	15	6.1	5.3	0	390	27.0	390	27.0	-	-	45-145	3.1-10	80	1/4	880VSN08T330BH000	6.8
3/4	0.78	20	8.5	7.4	0	130	9.0	130	9.0	-	-	55-145	3.8-10	50	1/8	880VSN12T320BH000	3.3
3/4	0.78	20	8.5	7.4	0	320	27.0	320	27.0	-	-	45-145	3.1-10	80	1/4	880VSN12T330BH000	6.8
1	1.00	25	14.3	12.4	0	60	4.1	60	4.1	-	-	68-145	4.7-10	50	1/8	880VSN16T320BH000	4.2
1	1.00	25	14.3	12.4	0	220	15.1	220	15.1	-	-	45-145	3.1-10	80	1/4	880VSN16T330BH000	7.7
1	1.00	25	14.3	12.4	0	390	27.0	390	27.0	-	-	29-145	2.0-10	125	1/4	880VSN16T352BH000	12.3
1-1/4	1.25	32	23.2	20.2	0	155	10.7	155	10.7	-	-	45-145	3.1-10	80	1/4	880VSN20T330BH000	10.6
1-1/4	1.25	32	23.2	20.2	0	260	18.0	260	18.0	-	-	32-145	2.2-10	125	1/4	880VSN20T352BH000	14.8
1-1/2	1.56	40	26.7	23.2	0	80	5.5	80	5.5	-	-	52-145	3.6-10	80	1/4	880VSN24T330BH000	14.8
1-1/2	1.56	40	26.7	23.2	0	160	11.0	160	11.0	-	-	32-145	2.2-10	125	1/4	880VSN24T352BH000	14.8

316 STAINLESS BODY VALVES										MIXING VALVE DATA (pilot option #4)							
Port Size	Orifice Size		Flow Coeff		Min	Operating Pressure			Pilot Pressure		Actuator		Valve Number Stainless (1)	Wt. lbs			
	inch	DN (mm)	Cv	Kv (m ³ /h)		psi air, gases	bar water, liquids	psi bar steam	psi	bar	mm dia	port bsp					
1/2	0.59	15	6.1	5.3	0	50	3.4	50	3.4	-	-	57-145	3.9-10	50	1/8	880VSN08T420BH000	3.3
1/2	0.59	15	6.1	5.3	0	290	20.0	290	20.0	-	-	45-145	3.1-10	80	1/4	880VSN08T430BH000	6.8
3/4	0.78	20	8.5	7.4	0	50	3.4	50	3.4	-	-	57-145	3.9-10	50	1/8	880VSN12T420BH000	3.3
3/4	0.78	20	8.5	7.4	0	290	20.0	290	20.0	-	-	45-145	3.1-10	80	1/4	880VSN12T430BH000	6.8
1	1.00	25	14.3	12.4	0	20	1.4	20	1.4	-	-	60-145	4.2-10	50	1/8	880VSN16T420BH000	4.2
1	1.00	25	14.3	12.4	0	160	11.0	160	11.0	-	-	45-145	3.1-10	80	1/4	880VSN16T430BH000	7.7
1	1.00	25	14.3	12.4	0	350	24.0	350	24.0	-	-	29-145	2.0-10	125	1/4	880VSN16T452BH000	12.3
1-1/4	1.25	32	23.2	20.2	0	110	7.6	110	7.6	-	-	50-145	3.6-10	80	1/4	880VSN20T430BH000	10.6
1-1/4	1.25	32	23.2	20.2	0	232	16.0	232	16.0	-	-	35-145	2.3-10	125	1/4	880VSN20T452BH000	14.8
1-1/2	1.56	40	26.7	23.2	0	60	4.1	60	4.1	-	-	50-145	3.6-10	80	1/4	880VSN24T430BH000	10.6
1-1/2	1.56	40	26.7	23.2	0	115	8.0	115	8.0	-	-	35-145	2.3-10	125	1/4	880VSN24T452BH000	14.8

316 STAINLESS BODY VALVES										NORMALLY OPEN VALVE DATA (pilot option #6)							
Port Size	Orifice Size		Flow Coeff		Min	Operating Pressure			Pilot Pressure		Actuator		Valve Number Stainless (1)	Wt. lbs			
	inch	DN (mm)	Cv	Kv (m ³ /h)		psi air, gases	bar water, liquids	psi bar steam	psi	bar	mm dia	port bsp					
1/2	0.59	15	6.1	5.3	0	175	12.0	175	12.0	-	-	45-145	3.3-10	50	1/8	880VSN08T620BH000	3.3
1/2	0.59	15	6.1	5.3	0	580	40.0	580	40.0	-	-	18-145	1.3-10	80	1/4	880VSN08T630BH000	6.8
3/4	0.78	20	8.5	7.4	0	175	12.0	175	12.0	-	-	45-145	3.3-10	50	1/8	880VSN12T620BH000	3.3
3/4	0.78	20	8.5	7.4	0	580	40.0	580	40.0	-	-	18-145	1.3-10	80	1/4	880VSN12T630BH000	6.8
1	1.00	25	14.3	12.4	0	100	7.0	100	7.0	-	-	50-145	3.4-10	50	1/8	880VSN16T620BH000	4.2
1	1.00	25	14.3	12.4	0	390	27.0	390	27.0	-	-	18-145	1.3-10	80	1/4	880VSN16T630BH000	7.7
1-1/4	1.25	32	23.2	20.2	0	232	16.0	232	16.0	-	-	20-145	1.4-10	80	1/4	880VSN20T630BH000	10.6
1-1/2	1.56	40	26.7	23.2	0	150	10.3	150	10.3	-	-	20-145	1.4-10	80	1/4	880VSN24T630BH000	14.8

(1) Chrome Plated Brass Actuator Standard, Anodized Aluminum for 125mm housing

Series 880: 3 Way Angle Body Valves: 1/2" to 1-1/2" NPT

On Off Control

How the Valve Functions

Normal function, normally closed

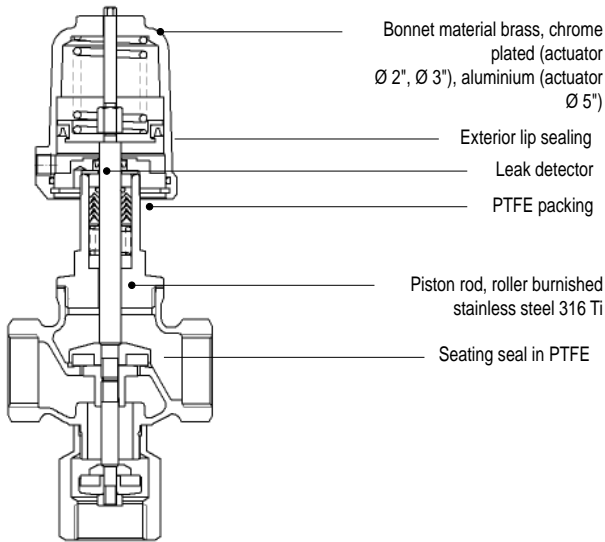

Distributing and mixing function

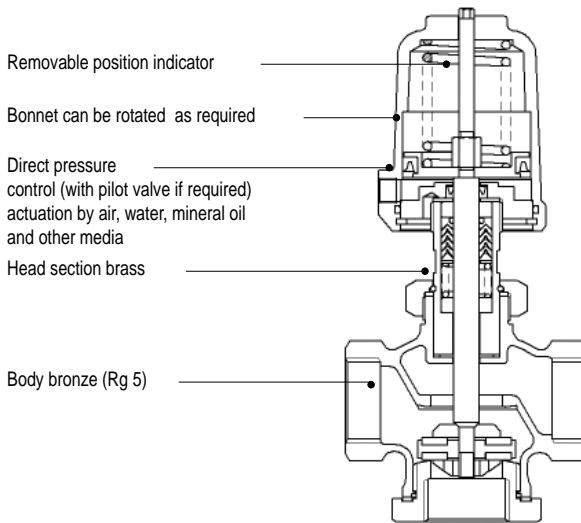

Distributing Function (Pilot Option #3)

Bronze: Actuator Diameter 2" (50 mm)

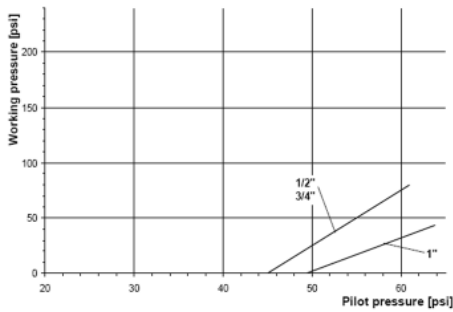

Bronze: Actuator Diameter 3" (80 mm)

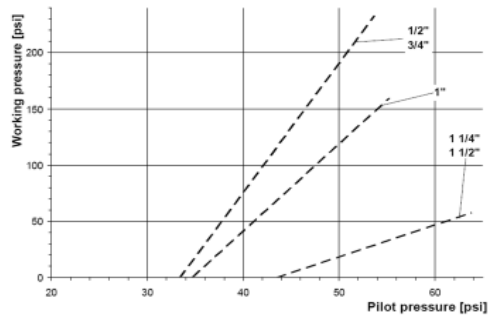

Stainless Steel: Actuator Diameter 2" (50 mm)

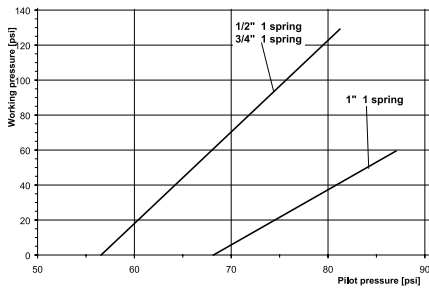

Stainless Steel: Actuator Diameter 3" (80 mm)

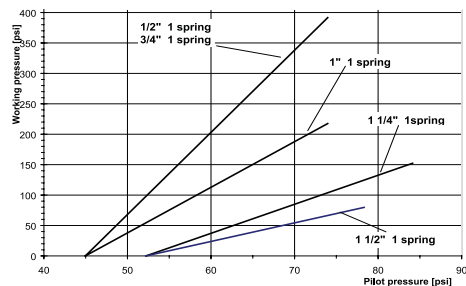

Series 880: 3 Way Angle Body Valves: 1/2" to 1-1/2" NPT

Distributing Function (Pilot Option #3)

Bronze: Actuator Diameter 5" (125 mm)

Stainless Steel: Actuator Diameter 5" (125 mm)

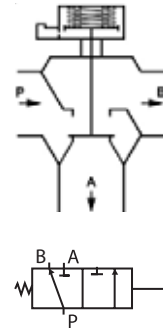
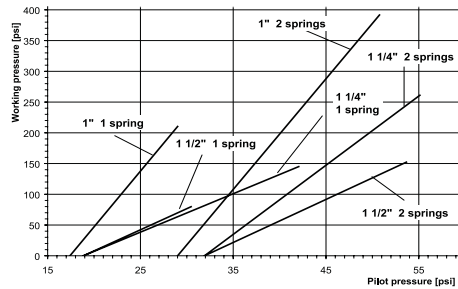
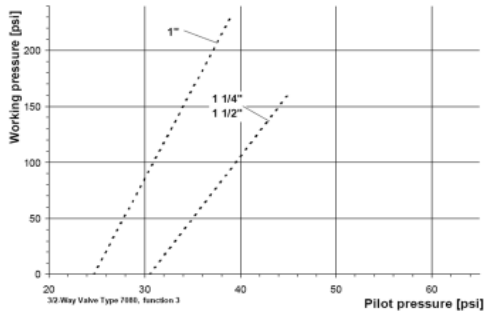

Mixing Function (Pilot Option #4)

Bronze: The valve may be used up to the nominal pressure of 232 psi, if the difference pressure between P1 and P2 does not exceed the admissible maximum value of ΔP_{max} .

Size	P _{max} psi	Pilot pressure psi	Actuator inch
1/2"	0 - 50	65 - 145	2"
1/2"	0 - 232	60 - 90	3"
3/4"	0 - 50	65 - 145	2"
3/4"	0 - 232	60 - 90	3"
1"	0 - 20	65 - 145	2"
1"	0 - 140	65 - 90	3"
1"	0 - 232	45 - 50	5"
1 1/4"	0 - 60	75 - 130	3"
1 1/4"	0 - 130	50 - 75	5"
1 1/2"	0 - 60	75 - 130	3"
1 1/2"	0 - 130	50 - 75	5"

Stainless Steel: Actuator Diameter 2" (50 mm)

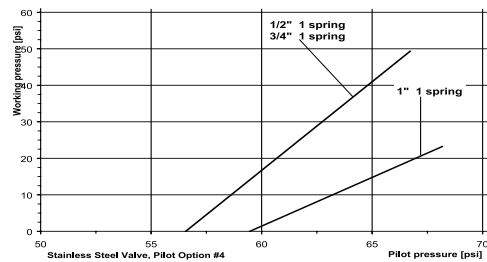

Stainless Steel: Actuator Diameter 3" (80 mm)

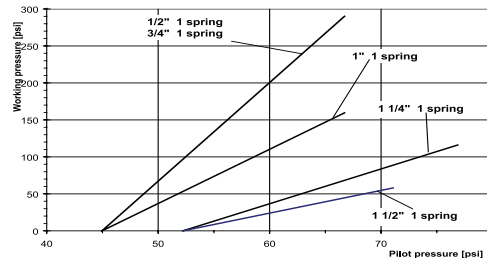

Stainless Steel: Actuator Diameter 5" (125 mm)

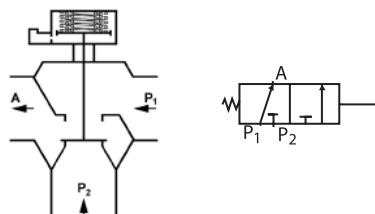
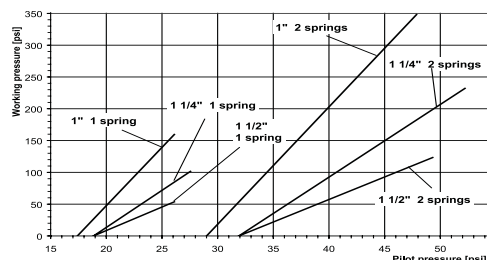

Series 880: 3 Way Angle Body Valves: 1/2" to 1-1/2" NPT

On Off Control

BRONZE: Normally Closed Function (Pilot Option #5)

Actuator diameter 2" (50 mm)

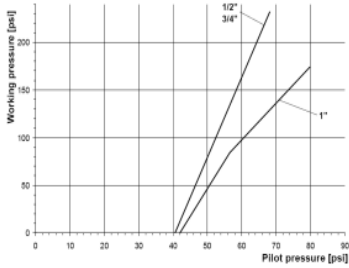

Actuator diameter 3" (80 mm)

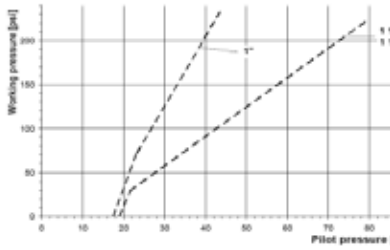

Actuator diameter 5" (125 mm)

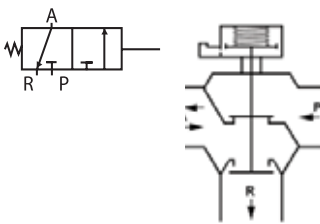
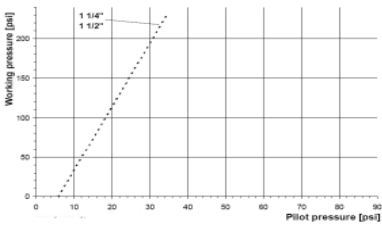

BRONZE: Normally Open Function (Pilot Option #6)

Actuator diameter 2" (50 mm)

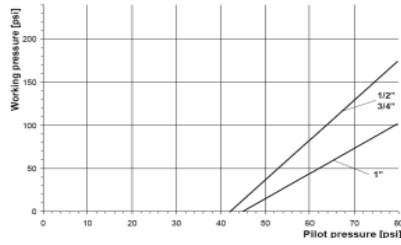

Actuator diameter 3" (80 mm)

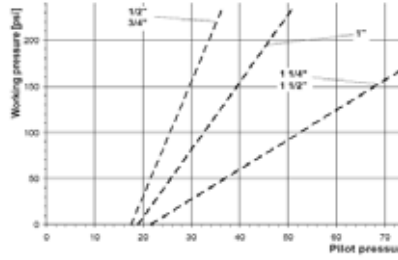

Actuator diameter 5" (125 mm)

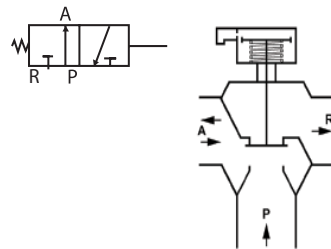
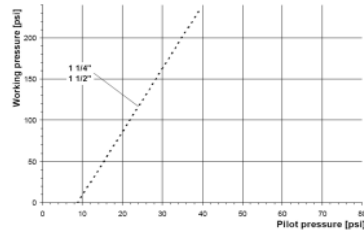

STAINLESS STEEL: Normally Open Function (Pilot Option #6)

Actuator diameter 2" (50 mm)

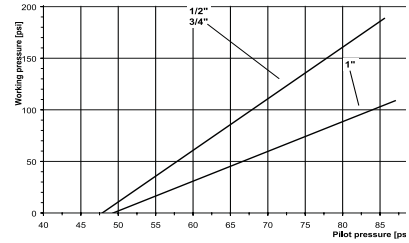

Actuator diameter 3" (80 mm)

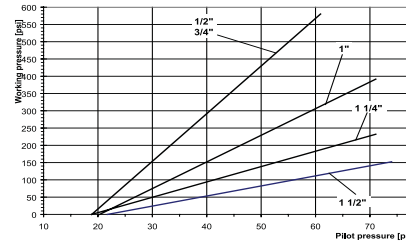

Actuator diameter 5" (125 mm)

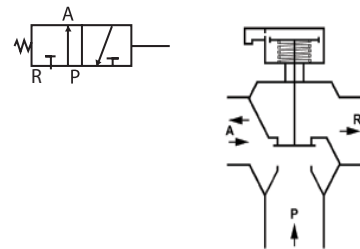
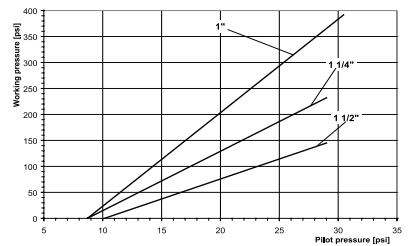



Series 880: 3 Way Angle Body Valves: 1/2" to 1-1/2" NPT

Dimensions and Weights: Body with Threaded Ends

On Off Control

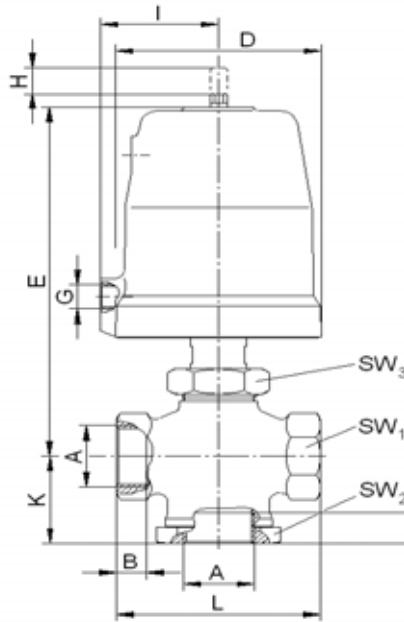

Distributing and mixing function

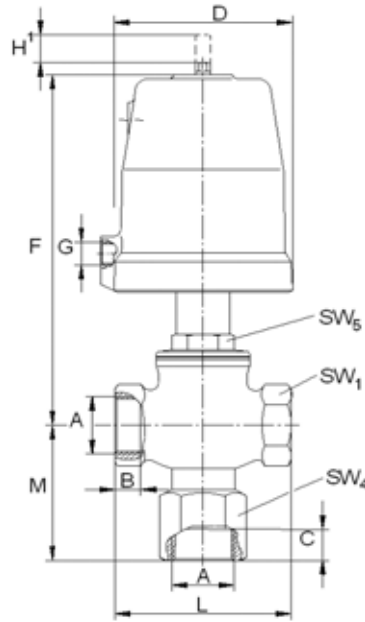

Normal function, normally closed

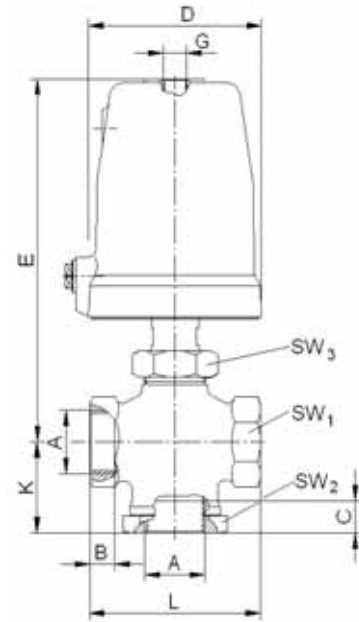

Normal function, normally open

A Pipe Size NPT	Actuator Diameter mm	DN	B	C	D	E	F	G	H stroke	I	J stroke	K	L	M	SW1	SW2	SW3	SW4	SW5	Cv	Weight	
																					lbs.	Kg.
1/2"	50	15	0.50	0.60	2.45	6.00	5.80	G 1/8"	0.35	1.35	0.20	1.55	3.15	2.70	1.30	1.60	1.60	1.40	1.20	6.1	3.3	1.5
1/2"	80	15	0.50	0.60	3.85	7.50	7.30	G 1/4"	0.35	2.15	0.20	1.55	3.15	2.70	1.30	1.60	1.60	1.40	1.20	6.1	6.8	3.1
3/4"	50	20	0.50	0.60	2.45	6.00	5.80	G 1/8"	0.35	1.35	0.20	1.65	3.15	2.70	1.30	1.60	1.60	1.40	1.20	8.5	3.3	1.5
3/4"	80	20	0.50	0.60	3.85	7.50	7.30	G 1/4"	0.35	2.15	0.20	1.65	3.15	2.70	1.30	1.60	1.60	1.40	1.20	8.5	6.8	3.1
1"	50	25	0.55	0.70	2.45	6.00	6.50	G 1/8"	0.43	1.35	0.31	1.85	3.75	2.85	1.60	2.15	1.60	1.60	1.20	14.3	4.2	1.9
1"	80	25	0.55	0.70	3.85	7.50	8.05	G 1/4"	0.43	2.15	0.31	1.85	3.75	2.85	1.60	2.15	1.60	1.60	1.20	14.3	7.7	3.5
1"	125	25	0.55	0.70	5.75	8.45	9.00	G 1/4"	0.43	3.15	0.31	1.85	3.75	2.85	1.60	2.15	1.60	1.60	1.20	14.3	12.3	5.6
1-1/4"	80	32	0.70	0.75	3.85	8.20	8.30	G 1/4"	0.73	2.15	0.35	2.40	5.20	3.65	2.30	2.95	1.60	2.15	1.25	23.2	10.6	4.8
1-1/4"	125	32	0.70	0.75	5.75	9.15	9.25	G 1/4"	0.73	3.15	0.35	2.40	5.20	3.65	2.30	2.95	1.60	2.15	1.25	23.2	14.8	6.7
1-1/2"	80	40	0.70	0.75	3.85	8.20	8.30	G 1/4"	0.73	2.15	0.35	2.40	5.20	3.65	2.30	2.95	1.60	2.15	1.25	26.7	10.6	4.8
1-1/2"	125	40	0.70	0.75	5.75	9.15	9.25	G 1/4"	0.73	3.15	0.35	2.40	5.20	3.65	2.30	2.95	1.60	2.15	1.25	26.7	14.8	6.7

Dimension in inches except as noted

810/880 Series Valve Ordering

On Off Control

1. Series	2 Configuration	3. Body Material	4 Connection Type	5. Port / Orifice Inches / DN	6. Seal Material	7 Pilot Function
810 880	V Valve Assembly	B Bronze & Brass	N NPT-thread	04 1/4" DN08	T PTFE	For 810 Valve Series 1 NC (closing with flow - over seat) 2 NO (closing against flow - under seat) 3 NC (closing against flow - under seat) 4 Universal, double acting For 880 Valve Series 3 Distributing Valve 4 Mixing Valve 5 Normally Closed Valve 6 Normally Open Valve
	A Actuator Unit less Body	S Stainless Steel 316L	G BSP- ISO	06 3/8" DN10	P PEEK	
	R Repair Kit		A Weld Ends - ISO	08 1/2" DN15		
			C ANSI Flanges 150#	12 3/4" DN20		
			E Tube Ends	16 1" DN25	Consult factory for other seal materials	
			T Tri Clamp inch (ASME 1998)	20 1-1/4" DN32		
				24 1-1/2" DN40		
				32 2" DN50		
				40 2-1/2" DN65		
				48 3" DN80		

8 Actuator Diameter	9. Springs	10. Actuator Head Material	11. Temperature Version	12 Packing	13 Accessories	14 Additional
2 Piston 2" (50mm)	0 Standard	B Brass Plated, Alum Anodized for 5" size	H High Temperature standard (392°F / 200°C) (bronze, stainless steel)	0 Standard - PTFE Graphite Filled	0 No accessories 1 Electrical position indicator with single switch	0 No additional accessories
3 Piston 3" (80mm)	2 2 springs	S Stainless Steel 316 (Option for stainless body valves only)	U Ultra High Temperature (430°F stainless steel)	1 PTFE free	2 Electrical position indicator with double switches	1 Pilot Valve .078 (DN2) 120/60, 110/50 DIN coil
5 Piston 5" (125mm)	3 3 springs		L Low Temperature (-40°F / -40°C)	2 Inverted packing for Vacuum Service only	3 4 Manual override (N.C.) 5 Stroke limitation(N.C.) 6 Electrical position indicator compact 7 Position indicator with 2 proximity switches 8 Position indicator with 1 proximity switch 9 Proximity position indicator compact A ASI BUS (IP65)	2 Pilot Valve .078 (DN2) 240/60, 220/50 DIN coil 3 Pilot Valve .078 (DN2) 24/60 DIN coil 4 Pilot Valve .078 (DN2) 24VDC DIN coil 5 Pilot Valve .078 (DN2) 12VDC DIN coil S Silicone Free X Oxygen Service

Accessories Selections

Numerous accessory options can be ordered and assembled to on-off pneumatic piston actuator valves. These include:

Position Indicator Switches

Indicator with single electrical switch – **Option Code "1"**

Indicator with double electrical switches – **Option Code "2"**

- Mounts on top of the actuator in place of the standard optical indicator
- Compact NEMA 4 housing

ELECTRICAL SWITCHES		
Breaking Capacity	6 A	5 A
Voltage	250 V AC	4 – 30 V DC
Protection Class	IP 54	
Amb. Temp	-4°F (-20°C) up to 176°F (80°C)	



Manual Override for Normally Closed Valves – Option Code "4"

- Available for normally closed operation when valve is de-pressurized

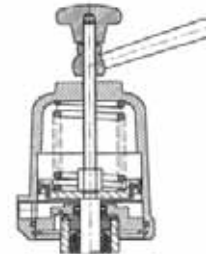

Stroke Limitation – Option Code "5"

- Adjustable minimum and maximum flow settings from 0% to 100% Cv flow
- Available for normally closed and normally open valves
- Easy adjustment with threaded rod



Compact Electrical Position Indicator – Option Code "6"

- Mounts on top of the actuator in place of the standard optical indicator

MECHANICAL SWITCH	
Breaking Capacity	5 A 230 V AC (resistor)
	5 A 230 V AC (coil)
	0.5 A 230 V AC (filament lamp)
	2 A 15 - 30 V DC
Amb. Temp.	14°F (-10°C) up to 160°F (70°C)
Protection Class	IP 43

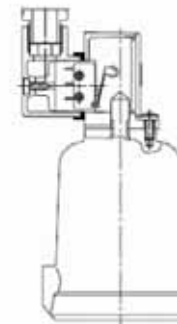

Proximity Indicator Switches

Indicator with 2 inductive proximity switches – **Option Code “7”**

Indicator with 1 inductive proximity switch – **Option Code “8”**

- Mounts on top of the actuator in place of the standard optical indicator
- Compact NEMA 4 housing

INDUCTIVE PROXIMITY SWITCHES	
Breaking Capacity	200mA
Voltage	10 – 36 VDC
Amb. Temp	-13°F (-20°C) up to 176°F (80°C)
Protection Class	IP67
Wiring	PNP or NPN
	Optional Explosion Proof and High Voltage Versions



Compact Inductive Proximity Switch – Option Code “9”

- Activates switch when valve is fully open
- Mounts on top of the actuator in place of the standard optical indicator
- Compact NEMA 4 housing

COMPACT INDUCTIVE PROXIMITY SWITCH	
Breaking Capacity	200 mA
Voltage	10 - 30 V DC
Amb. Temp.	-13°F (-20°C) up to 212°F (100°C)
Protection Class	IP 67





3 Way Direct Acting Pilot Control Valves

FEATURES

Pilot Control Valve

- Compact design for industrial applications
- Brass or stainless steel body valves
- NC (normally closed) and NO (normally open) versions
- Rugged coil family for all application demands
- Manual operation optional



On Off Control

Technical Specifications

Function	3/2 Normally Closed, Normally Open and Multi-Purpose	
Connections: NPT thread standard	1/8" - 1/4"	
Differential Pressure	See Specifications tables	
Pilot Control Media	Air, neutral gas, water	
Max. fluid temperature	-20°F (-23°C) up to 185°F (85°C)	
Ambient temperature	-20°F (-23°C) up to +140°F (60°C)	
Viscosity of the fluid	max.22 mm ² /s (22cSt, 3°E, 100SSU)	
Installation	Any position	
Manual Locking Control	Optional	
Materials	Body	Brass (stainless optional)
	Sleeve	Stainless
	Core	Stainless
	Spring	Stainless
	Seals	FKM
Coils	DIN coil standard Conduit & Hazardous coils optional	

port size	orifice size inch mm	Flow Coef		air psi	water psi	oil psi	AC VALVE NUMBERS	air psi	water psi	oil psi	DC VALVE NUMBERS
		Cv	Kv (m ³ /h)								
BRASS UNIVERSAL VALVE FOR NORMALLY CLOSED & NORMALLY OPEN REQUIREMENTS											
1/8	1/16	1.5	0.11	0.10	150	150	150	150	150	150	7133KBN1GVJ1N0D5D1xx
1/8	5/64	2.0	0.17	0.15	100	100	100	100	100	100	7133KBN1JVJ1N0D5D1xx
1/4	1/16	1.5	0.11	0.10	150	150	150	150	150	150	7133KBN2GVJ1N0D5D1xx
1/4	5/64	2.0	0.17	0.15	100	100	100	100	100	100	7133KBN2JVJ1N0D5D1xx
STAINLESS NORMALLY CLOSED											
1/8	1/16	1.5	0.10	0.09	200	200	200	200	200	200	71315SN1GV00N0D5D1xx
1/4	3/32	2.4	0.17	0.15	125	125	125	125	125	125	71315SN2KV00N0D5D1xx
STAINLESS NORMALLY OPEN											
1/8	1/16	1.5	0.10	0.09	150	150	150	150	150	150	71395SN1GVJ1N0D5D1xx
1/4	3/32	2.4	0.17	0.15	125	125	125	125	125	125	71395SN2KVJ1N0D5D1xx
1 bar = 14.5 psi							AC VoltageCodes			DC VoltageCodes	
							P3 = 120/60; 110/50			C1 = 12VDC	
							Q3 = 240/60; 220/50			C2 = 24VDC	
* xx - Replace with voltage code							B2 = 24/60; 24/50				

3 Way Direct Acting Pilot Control Valves





ELECTRICAL SELECTION GUIDE

All Parker solenoid valves for pneumatic actuator control use standard coil designs that are interchangeable. They are available in a wide variety of standard voltages and frequencies. Coils are labeled with electrical data providing easy identification.

Construction

Encapsulated waterproof coils are standard on all pilot valves. Numerous construction options are available including DIN terminals and conduit hub housing coils. The special compound is absolutely waterproof and impervious to oil, dust and most corrosive fumes and vapors.

All coils are Class “F” rated for high temperature application requirements. Class H coils is optional. The coils are molded in accordance with UL, NEMA, and other accepted standards.

Coil Code*	Class	Wattage	Description	
D4D1xx	F	13	DIN AC Voltages(terminations per DIN 43650 / ISO 4400 requirements)	
D5D1xx	F	16	DIN DC Voltages(terminations per DIN 43650 / ISO 4400 requirements)	
C111xx	F	10	Conduit, NEMA 4X 18" lead length, 2-wires	
H111xx	F	10	Hazardous, NEMA 4X, 7, 9 18" lead length, 2-wires	

* xx- Replace with voltage code

DIN coils are provided standard as noted in order table.

To select the either conduit version coil, simply specify the coil number and voltage in positions 15 through 20 of the valve number.

Example: To order 1/4" NPT brass body NC valve with NEMA 4 conduit coil rated for 120/60 voltage:
7133KBN2JVJ1+N0+C111P3 = 7133KBN2JVJ1N0C111P3

To order the pressure vessel alone, select only the pressure vessel number, the first 12 digits of the part number.

To select coil alone, select the 4-digit coil part and 2-digit voltage code.

Electrical Supply Requirements

The solenoid coil must be connected to electrical lines of correct voltage and frequency as indicated on the coil label. The supply circuits must be properly sized to give adequate voltage at the coil leads even when other electrical equipment is operating. The molded coil is designed to operate with line voltage from 85% to 110% of the coil rated voltage. Operating with a line voltage above or below these limits may result in reduced coil life or coil burn out. Also, operating with line voltage below the limit will result in lowering the maximum operating pressure differential (MOPD).

Conversion from AC to DC Coils

The same valve assembly can be used for both AC and DC service requirements. AC and DC coils are interchangeable. To convert a valve assembly from AC to DC service, select the appropriate DC coil voltage per the valve specification chart based on the system pressure requirements.

3 Way Direct Acting Pilot Control Valves

ELECTRICAL DATA

To determine the approximate Holding or Inrush Current for AC voltages including 24/60, 120/60, 208/60 and 240/60 in amperes, divide the voltage into the VA rating indicated in the AC Power Consumption tables. DC valves have no inrush current. The current rating in amperes are shown in the DC table. Figures are based on nominal values and will vary slightly depending on operating voltage and coil tolerances.

Valve Series	AC Power Consumption Ratings		DC Current Consumption Ratings (Amperes)	
	10 watt AC coils		10 watt DC coils	
	VA Holding	VA Inrush	12VDC	24VDC
7133K	17	31	0.81	0.41
71315	16	30	0.81	0.41
71395	17	27	0.81	0.41

