

TABLE OF CONTENTS

INTRODUCTION/1

AVAILABLE VALVE ACTUATION SERIES PRODUCTS/2-3

FEATURES AND BENEFITS/4-6

PRODUCT LINE CHART/7

3-WAY SOLENOID VALVES/8-12

7700 Line/9

7300 Line/10

7000 Series/11-12

4-WAY SOLENOID VALVES/13-16

7700 Line/14

7300 Line/15

7000 Series/16

INTRINSICALLY SAFE SOLENOID VALVES/17-19

I.S. Ordering Information/19

ULTRA LOW-POWER SOLENOID VALVES/20-21

MANUAL RESET SOLENOID VALVES/22-23

DIRECT MOUNT SOLENOID VALVES/24-25

COILS, OPTIONS AND ACCESSORIES/26-32

VALVE ORDERING/33

PART NUMBERING SYSTEM/34-35

ADDITIONAL TECHNICAL INFORMATION/36-44

OUTLINE DRAWINGS/45-52

WARNING 

FAILURE OR IMPROPER SELECTION OR IMPROPER USE OF THE PRODUCTS AND/OR SYSTEMS DESCRIBED HEREIN OR RELATED ITEMS CAN CAUSE DEATH, PERSONAL INJURY AND PROPERTY DAMAGE.

This document and other information from Parker Hannifin Corporation, its subsidiaries and authorized distributors provide product and/or system options for further investigation by users having technical expertise. It is important that you analyze all aspects of your application and review the information concerning the product or system in the current product catalog. Due to the variety of operating conditions and applications for these products or systems, the user, through its own analysis and testing, is solely responsible for making the final selection of the products and systems and assuring that all performance, safety and warning requirements of the application are met.

The product described herein, including without limitation, product features, specifications, designs, availability and pricing, are subject to change by Parker Hannifin Corporation and its subsidiaries at any time without notice.

Offer of Sale

The items described in this document are hereby offered for sale by Parker Hannifin Corporation, its subsidiaries or its authorized distributors. This offer and its acceptance are governed by the provisions stated on the separate page of this document entitled "Terms and Conditions of Sale". (See page 60.)



Valve Actuation Series

Solenoid Valves for



Actuator Automation



The Skinner Valve Actuation Series of solenoid valves includes the new 7700 and 7300 Lines of 3- and 4-way valves, as well

as: All-Ports-In-Body valves; Intrinsicly Safe valves; Quick Exhaust valves; Direct Mount valves with NAMUR interface;



Ultra Low-Power valves; and a host of accessories and options.

In addition, to satisfy the most stringent environmental demands, most valves are available in a choice of body materials including brass, stainless steel, aluminum and others, as well as a variety of elastomeric seals.



Available Skinner Valve Actuation Series Solenoid Valves

The Skinner Valve Actuation Series includes a variety of new 3- and 4-way valves designed with unique features and options enhancing their performance, operational reliability and application versatility.

The Actuation Series 7300 and 7700 Lines come with standard features which include: integral pilot filtration, captured pusher cavity exhaust; air-assisted spring return and a tag mount provision. Also available are horizontal operators, field convertible manual overrides, momentary manual overrides and captured exhaust pilot.

Valve Actuation Series 3- and 4-Way 7700 Line

The 7700 Line of 3- and 4-way solenoid valves incorporate a number of unique features including: captured exhaust pilot; integrated main exhaust; and integral metering. They are available in brass, stainless steel, and aluminum bodies in single or double solenoid versions and are also available as externally piloted valves. There is also a field convertible manual override option.

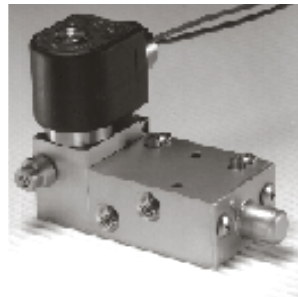

Valve Actuation Series 3- and 4-Way 7300 Line

The 7300 Line of 3- and 4-way valves has the same quality of design and materials found in the 7700 Line. Like the 7700 Line, the 7300 Line includes the following standard features: integral pilot filtration; captured pusher cavity exhaust; air-assisted spring return; and tag mount provision. They are available in single and double solenoid versions and are also available as externally piloted or

remotely piloted units. There are also captured exhaust pilot, momentary manual override and field convertible manual overrides as options. They are available in brass, stainless steel and aluminum bodies.

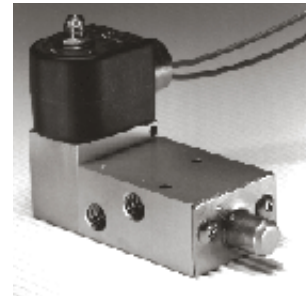

Actuation Series Standard 3- and 4-Way Valves

Standard 3- and 4-Way Actuation Series valves include a selection of time proven 7000 Series valves: Normally Open, Normally Closed, Multipurpose, Quick Exhaust, All-Ports-In-Body and pilot operated 4-way valves. Most are available in stainless steel constructions, some are available in brass or aluminum.



Intrinsically Safe Solenoid Valves

Skinner Intrinsically Safe solenoid valves have been developed for use in environments where fire and explosive hazards exist due to the presence of flammable gases, vapors, liquids, combustible dusts, or easily ignitable fibers.

When designed into an intrinsically safe system, Skinner Intrinsically Safe valves provide low-power consumption, low-temperature rise, wide range of sizes (3- and 4-way configurations), watertight construction equivalent to NEMA 4, suitable for use with air and inert gases, and can be mounted in any position to operate.

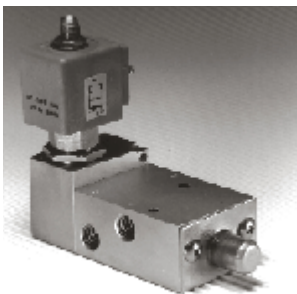

Ultra Low-Power Solenoid Valves

Skinner Ultra Low-Power solenoid valves incorporate a unique operator designed to keep current draw to a minimum power consumption level of 0.6 watts. No refresh time is required.

The valves are ideally suited for use in automated control

systems, applications where minimizing energy consumption is critical, or where heat rise in the coil must be kept to a minimum. These devices allow for an increased number of solenoids to be driven from the same power source reducing the overall installation cost.

Ultra Low-Power valves are available in 3- and 4-way construction in single or double solenoid models. Coils are available in integrated designs in both NEMA 4X and NEMA 4X, 7 and 9 versions.

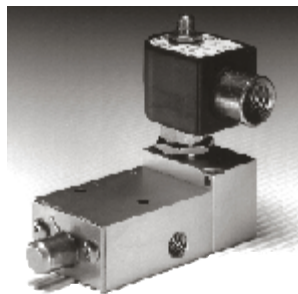

Manual Reset Solenoid Valves

Skinner Manual Reset valves are ideally suited for use as a safety device on valves which, when triggered, must remain in their “at rest” position until the reset mechanism is manually set or latched. Typical applications include use in processing, power and chemical plants.

The Manual Reset option permits a valve to be tripped either upon loss of power to the coil or when power is applied to the coil. This action is accomplished through two different types of manual reset

configurations; No-Voltage-Release and Electrically Tripped.

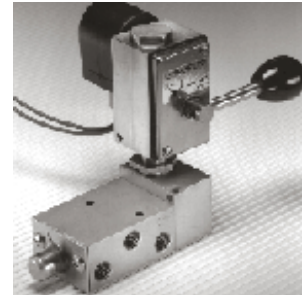

Direct Mount (NAMUR Patterned) Solenoid Valves

Honeywell offers NAMUR flange patterned Skinner solenoid valves in direct acting 3-way, pilot operated 3- and 4-way, single and double solenoid versions, aluminum and stainless steel constructions.

Honeywell has one of the broadest lines of NAMUR-mounted offerings in the world.

All 4-way models are provided with a unique 3-way/4-way conversion plate. In the 3-way configuration, the plate channels return air from the cylinder port to the spring cavity of the actuator, substantially prolonging the life of the actuator.

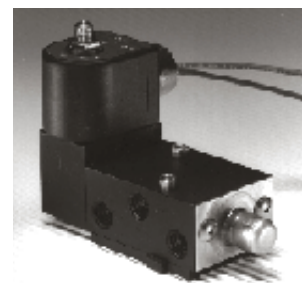

Features and Benefits

When Used for
Control of Pneumatic
Actuators, Actuation
Series Solenoid
Valves Provide
Distinct Advantages
and Benefits.

Enhanced Reliability of Operation

Because most process applications require the process control valve, and its controlling solenoid valve, to be exposed to the most severe operating environments, Skinner Valve has built into its new Actuation Series 7700 and 7300 Lines a number of specific features which enhance their performance and operating reliability.

- *Unique seal, spool and cage design is ideally suited to meet a wide range of environmental conditions: temperatures from -40°F (-40°C) to 167°F (75°C); pressure ranges of 30-150 PSI.*
- *Integral Pilot Filtration—Internally filtered pilot air supply inhibits pilot orifice fouling and further improves the performance of the valve.*
- *Contamination-Tolerant Design—Tolerant to entrained pneumatic supply particulates to 40 microns.*
- *Integrated Main Exhaust (7700 Exclusive)—All air exiting from the valve is channeled through a single exhaust port. This reduces the number of external openings and minimizes ambient contamination entering the valve.*
- *Captured Exhaust Pilot—Eliminates the need to vent pilot exhaust directly to the atmosphere, thus preventing the entrance of water, ice, bugs, and the like into the pilot chamber and adversely affecting valve reliability.*
- *Captured Pusher Cavity Exhaust—The Pusher cavity is internally vented to eliminate external contamination and installation limitations associated with exposed ports/orifices.*
- *Air-Assisted Spring Return—Air supplements return spring force on the de-energized (reset) cycle, thus improving the return stroke reliability.*

Versatility

Regardless of the environment the valve may be used in, Skinner Valve Actuation Series products have the versatility to handle it. The wide selection of body materials, electrical enclosures, power ratings, and other application specific features make this series ideal for all process applications.

- *Integral Metering (7700 Exclusive)—Independently controls the actuator speed in both directions on 4-way valves and the actuator return speed on 3-way valves.*
- *Wide Ambient Temperature Range—Products are available that operate from -40°F (-40°C) to 250°F (121°C).*
- *Body Materials—Available to suit a wide range of exposures including: 316L, 430F and 303 Stainless Steel; hard-coat anodized low-copper aluminum or brass.*
- *Wide Pressure Range—From 0 to 215 PSI, the valves are ideally suited for valve actuation.*
- *Operator Orientation—Available in a variety of configurations to address different spacing and mounting requirements.*
- *Mounting Configuration—Both pipe mount and direct mount are available.*
- *Double Solenoids—For “fail as is” applications.*
- *Multipositioned Operator—The solenoid operator may be mounted in any position without affecting valve performance.*

- *Remotely Piloted*—For applications where the electrical portion of the valve is not located at the process valve.
- *Externally Piloted*—When the controlled air signal is less than the requirement of the solenoid valve, a separate air signal can be used to operate the valve.
- *Tag Mount Provision*—A dedicated feature for ease of installation of a tag.
- *Global Porting*—Both NPT and BSP porting available.
- *Wide Voltage Range*—AC units from 24 to 480 volts and DC units from 12 to 125 volts.
- *Ultra Low-Power Coils*—Valves available down to 0.6 watts.
- *Global Approvals*—Watertight, explosion proof, Intrinsically Safe, non-incendive, Cenelec and more for use throughout the world.
- *Integrated, Encapsulated Coils*—Eliminate the need for separate metal housings while providing a NEMA 4X or NEMA 4X, 7 and 9 rating.
- *All Fasteners, Trim and Internal Wetted parts (including springs) are made of corrosion-resistant materials.*

Expansive Modularity for Application Flexibility

Skinner Valve Actuation Series solenoid valves have been developed in a modular configuration allowing for wide application flexibility. Whether pipe mounted or direct mounted to pneumatic actuators, Skinner solenoid valves can be configured to control any process valve equipped with a pneumatic positioning drive. Features include:

- *Field Convertible Manual Override*—A unique construction that allows the device to be converted from a latching manual override to a momentary manual override or to be locked, thus removing the override feature.
- *Multi-Function Direct Mount*—With a 3/4-way solenoid valve in NAMUR or customer-specific mounting flange plate.
- *Modular Main Body Architecture*—Facilitates use of air pilots (remote or external), single or dual solenoid, vertical pilot body, and horizontal pilot body.
- *AC/DC Compatible Pressure Vessels*—Pressure vessel can be fitted with either an AC or DC coil, ordinary or hazardous location construction for added flexibility.
- *Interchangeable Coil Options*—Standard power (10 watts), low-power (1.5 watts), Fluxtron® Electronic coils, Magnelatch® Latching coils, and NEMA 4X and NEMA 7/9 construction.

Whether your application is in chemical or petrochemical processing, power generation, petroleum refining, pulp and paper production, food and beverage, water and wastewater treatment, cement and glass manufacturing, or oil and gas exploration, there is an Actuation Series solenoid valve for your particular need.



Available Options and Accessories

A variety of options, accessories and coil/enclosure combinations are available for use with Skinner Valve Actuation Series solenoid valves.

State-of-the-Art Coil Technology

With application requirements differing for various uses in process automation, we offer a variety of time proven 7000 Series solenoid coils and technologies to suit your particular needs, including:

- *Integrated, Corrosion Resistant, encapsulated coils which do not require an external housing or yoke.*
- *Electronic and Conventional coil technology allows for use with electrical signals from control equipment.*
- *Low-Power Operation (1.5 Watt) and Ultra Low-Power (0.6 Watt) at standard pressure and flow rates so performance is not compromised.*
- *Ratings and Approvals include NEMA 4 X ordinary location, NEMA 7/9 hazardous location, Intrinsically Safe, and non-incendive.*

Additional Application Specific Features

Additional features and options available for Skinner Actuation Series solenoid valves include:

- *Manual Override to operate a valve without electrical power, to facilitate start-up procedures, and to perform diagnostic checks. This option is available in momentary, latching or field convertible versions.*
- *Spring Cavity Purge (3/2 function) with return air channeled from the actuator's piston side to the spring side on the spring stroke, thus prolonging the life of the actuator.*
- *Full Range Hazardous Location Approval Class I, Div. I, Groups A, B, C, D; Class II, Div. I, Groups E, F, G; Class III, Div. I.*
- *A range of accessories including: quick exhaust modules, exhaust adaptors, manual overrides and pilot guard.*

New High-Flow Solenoid Valves

For high-flow applications (4.0 C_v), Skinner Valve Actuation Series includes a number of three-way and four-way valves, as well as Ultra-Low Power valves and Intrinsically Safe solenoid valves.

Further Product Information

Detailed product information and specifications on Parker's Skinner Valve Actuation Series solenoid valves for process control can be found within this catalog. For additional information, contact our product application department at (860) 827-2300 or write Parker Hannifin Corporation, Skinner Valve Division, 95 Edgewood Avenue, New Britain, CT 06051.

PRODUCT LINE				CATALOG SECTION					
--------------	--	--	--	-----------------	--	--	--	--	--

	7700 Line	7300 Line	7000 Series	3-Way	4-Way	Intrinsically Safe	Ultra Low-Power	Manual Reset	Direct Mount
--	-----------	-----------	-------------	-------	-------	--------------------	-----------------	--------------	--------------

Product Type									
3-Way	A	A	A	-		A	A	A	A
4-Way	A	A	A		-	A	A	A	A
Intrinsically Safe		A				-		A	
Ultra Low-Power		A					-		
Manual Reset		A	A			A		-	
Direct Mount (NAMUR Patterned)	A	A	A			A	A		-
High Flow (4.0 C _v)		A				A	A		

Mechanical Features									
Integral Pilot Filtration	S	S		A	A	A	A	A	A
Integrated Main Exhaust	S			A	A	A	A	A	A
Captured Exhaust Pilot	S	A		A	A				A
Pilot Guard		A	A	A	A	A	A		A
Captured Pusher Cavity Exhaust	S	S		A	A	A	A	A	A
Air-Assisted Spring Return	S	S	A	A	A	A	A	A	A
Integral Metering	S			A	A				A
Low Temperature (-40°F)	S	A		A	A				A
Body	Brass	A	A	A	A	A	A	A	A
Materials	Stainless Steel	A	A	A	A	A	A	A	A
	Aluminum(*= Hard Coat)	A*	A*	A	A		A*		A*
Single Solenoid	A	A	A	A	A	A	A	A	A
Double Solenoid	A	A			A	A	A		A
Remotely Piloted		A		A	A				
Externally Piloted		A		A	A				A
Tag Mount Provision	S	S		A	A	A	A	A	A
Manual	Momentary	A	A	A	A	A	A		A
Overrides	Latching		A	A	A				
	Field Convertible	A	A	A	A	A	A		A
Spring Cavity Purge	A	A				A	A		A

Electrical Features									
									Power Consumption
Integrated Coils	NEMA4X	22		A	A				A
		10	A	A	A	A	A		A
		1.5	A	A		A	A		A
		0.6		A				A	
Specialty Coils	NEMA4X, 7, 9	22		A	A				A
		10	A	A	A	A	A		A
		1.5	A	A		A	A		A
		0.6		A				A	
Fluxtron	1.3	A	A	A	A	A			A
Magnelatch 0		A	A	A	A	A			A

A-Available, S-Standard

Three-Way Valves

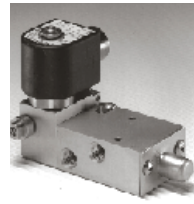

Skinner Valve

Actuation Series

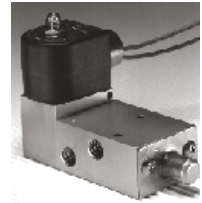

Three-Way



Solenoid Valves

Skinner three-way solenoid valves are ideally suited to control single-acting, spring return, pneumatic actuators and cylinders. Parker offers a variety of valve models in the 7300 and 7700 Lines and standard solenoid valves that afford the end user greater flexibility in selecting the optimum design to satisfy the application requirements.

With port sizes ranging from 1/4" to 3/4" NPT, the valves are available in normally open, normally closed, and multipurpose configurations. Depending on the model selected, orifice sizes from 1/16" to 3/4" provide flow factors (C_V) from 0.095 to 7.3 with operating pressure differentials of 0 to 215 PSI. To ensure proper system response, the valve orifice size, corresponding C_V flow factor and system pressure can be matched to the actuator to produce the desired opening and closing speeds. Constructed of brass or stainless steel, maximum environmental protection and corrosion resistance is assured.



7700

SKINNER 7700 LINE FEATURES

Standard Features

- Unique Seal, Spool and Cage Design
- Integral Pilot Filtration
- Contamination Tolerant Design
- Integrated Main Exhaust
- Captured Exhaust Pilot
- Captured Pusher Cavity Exhaust
- Air-Assisted Spring Return
- Integral Metering
- Tag Mount Provision
- 1.5 Watt Power Level

Optional Features

- Horizontal Oriented Solenoid Operators
- Field Convertible Manual Override

SPECIFICATIONS

Mechanical Characteristics

Standard Materials of Construction

- Body—Brass or 303 Stainless Steel
- Seals—NBR
- Spool—Thermoplastic
- Cages—Thermoplastic
- Sleeve Tube—Stainless Steel (304)
- Plunger—Stainless Steel (430 F)
- Stop—Stainless Steel (430 F)
- Springs—Stainless Steel (18-8 or 17-4)
- Metering
 - Stem—Stainless Steel (303)
 - Shutter—Stainless Steel (303)
 - Set Screw—Stainless Steel (300 Series)
- Filter—Polyethylene

Compatible Fluids

- Lubricated Air, Non-Lubricated Air, Inert Gases and other gases compatible with materials of construction.

Electrical Characteristics

Voltages

- DC—12, 24, 48
- AC—24/50/60, 110/50-120/60, 220/50-240/60
(other voltages available upon request)

Electrical Connections

- Leaded, 1/2" Conduit, DIN, Screw, Tab

Agency Approvals

- UL approvals are available on valves with applicable coil/enclosure combinations. For additional information see pages 40-41.

Miscellaneous

Minimum Ambient Temperature

- -40°F(-40°C)
Dew point must be more than 7°F below ambient.

Maximum Ambient Temperature

- 1.5 Watt AC—150°F (65°C)
- 10 Watt AC/DC—167°F (75°C)
- Fluxtron/Magnelatch—122°F(50°C)

Maximum Fluid Temperature

- 167°F (75°C)

Mounting Position

- Multipoised—valves may be installed in any position.

SKINNER 7700 LINE THREE-WAY VALVES

Pipe Size (NPT)	Orifice Size (Inches)	C _v Flow Factor	Operating Pressure Differential (PSI)				Brass Pressure Vessel Catalog Number	Stainless Steel Pressure Vessel Catalog Number	Constr. Ref.
			Min	Maximum					
				AC		DC			
				1.5 watt	10 watt	10 watt			
7700 Line									
1/4"	11/64	0.55	30	150	150	150	77317BN2KN7M	77317VN2KN7M	1
	1/4	1.2	30	150	150	150	77317BN2PN7M	77317VN2PN7M	1
7700 Line—External Pilot*									
1/4"	11/64	0.55	0	150	150	150	78317BN2KN7M	78317VN2KN7M	2
	1/4	1.2	0	150	150	150	78317BN2PN7M	78317VN2PN7M	2

* External pilot pressure to operate valve must be 30-150 PSI.

7300

SKINNER 7300 LINE FEATURES

Standard Features

- Unique Seal, Spool and Cage Design
- Integral Pilot Filtration
- Contamination Tolerant Design
- Captured Pusher Cavity Exhaust
- Air-Assisted Spring Return
- Tag Mount Provision
- 1.5 Watt Power Level

Optional Features

- Captured Exhaust Pilot
- Horizontal Oriented Solenoid Operators
- Momentary or Field Convertible Manual Overrides
- Exhaust Adaptors

SPECIFICATIONS

Mechanical Characteristics:

Standard Materials of Construction

- Body—Brass or 303 Stainless Steel
- Seals—NBR
- Spool—Thermoplastic
- Cages—Thermoplastic
- Sleeve Tube—Stainless Steel (304)
- Plunger—Stainless Steel (430 FR)
- Stop—Stainless Steel (430 FR)
- Springs—Stainless Steel (18-8 or 17-4)
- Filter—Polyethylene

Compatible Fluids

- Lubricated Air, Non-Lubricated Air, Inert Gases and other gases compatible with materials of construction.

Electrical Characteristics

Voltages

- DC—12, 24, 48
- AC—24/60, 110/50-120/60, 220/50-240/60 (other voltages available upon request).

Electrical Connections

- Leaded, 1/2" Conduit, DIN, Screw, Tab

Agency Approvals

- UL approvals are available on valves with applicable coil/enclosure combinations. For additional information see pages 40-41.

Miscellaneous

Minimum Ambient Temperature

- -40°F(-40°C)
- Dew point must be more than 7°F below ambient.

Maximum Ambient Temperature

- 1.5 Watt—150°F (65°C)
- 10 Watt—167°F (75°C)
- Fluxtron/Magnelatch—122°F(50°C)

Maximum Fluid Temperature

- 167°F (75°C)

Mounting Position

- Multipoised—valves may be installed in any position.

SKINNER 7300 LINE THREE-WAY VALVES

Pipe Size (NPT)	Orifice Size (Inches)	C _v Flow Factor	Operating Pressure Differential (PSI)				Brass Pressure Vessel Catalog Number	Stainless Steel Pressure Vessel Catalog Number	Constr. Ref.	
			Min	Maximum		Min				Max
				1.5 watt	10 watt					
7300 Line										
1/4"	11/64	0.55	30	150	150	150	150	73317BN2KN00	73317VN2KN00	3
	1/4	1.2	30	150	150	150	150	73317BN2PN00	73317VN2PN00	3
7300 Line—External Pilot*										
1/4"	11/64	0.55	0	150	150	150	150	74317BN2KN00	74317VN2KN00	4
	1/4	1.2	0	150	150	150	150	74317BN2PN00	74317VN2PN00	4
7300 Line—4.0 C_v, Single Solenoid										
1/2"	5/8	4.0	30	150	150	150	150	73317BN4UN00	-	29A
7300 Line—4.0 C_v, External Pilot										
1/2"	5/8	4.0	30	150	150	150	150	74317BN4UN00	-	29A
7300 Line—4.0 C_v, Remote Pilot										
1/2"	5/8	4.0	30	150	150	150	150	75317BN4UN00	-	29A
Pipe Size (NPT)	Orifice Size (Inches)	C _v Flow Factor	Operating Pressure Differential (PSI)				Brass Pressure Vessel Catalog Number	Stainless Steel Pressure Vessel Catalog Number	Constr. Ref.	
			Min	Maximum		Min				Max
7300 Line—Remote Operate**										
1/4"	11/64	0.55	30	150		75317BN2KN00		5		
	1/4	1.2	30	150		75317BN2PN00		5		

* External pilot pressure to operate valve must be 30-150 PSI. **Remote pilot pressure to operate valve = 35 PSI + .2 (main line pressure)

7000

SPECIFICATIONS

Mechanical Characteristics

Standard Materials of Construction

- Body—Brass or Stainless Steel (303 or 430F)
- Seals—NBR, FKM
- Sleeve Tube—Stainless Steel (304)
- Plunger—Stainless Steel (430 FR)
- Stop—Stainless Steel (430 FR)
- Springs—Stainless Steel (18-8)
- Shading Ring—Copper

Compatible Fluids

- Lubricated Air, Non-Lubricated Air, Inert Gases, Water, Hydraulic Fluids, Petroleum Products and additional fluids compatible with materials of construction.

Electrical Characteristics

Voltages

- DC—12, 24, 48
- AC—24/60, 110/50-120/60, 220/50-240/60 (other voltages available upon request)

Electrical Connections

- Leaded, 1/2" Conduit, DIN, Screw, Tab

Agency Approvals

- UL approvals are available on valves with applicable coil/enclosure combinations. For additional information see pages 40-41.

Miscellaneous

Maximum Ambient Temperature

- 10 Watt—150°F (65°C)
- 22 Watt—77°F (25°C)
- Fluxtron/Magnelatch—122°F (50°C)

Mounting Position

- Multipoised—valves may be installed in any position.

Maximum Fluid Temperature

- Class F coils—185°F (85°C)
- Maximum fluid temperatures are provided for Class F coils. Valves with FKM seals (letter "V" in 10th position of pressure vessel number) can be used at fluid temperatures up to 240°F (115°C) on DC and 250°F (120°C) on AC provided a Class H coil is used.



SKINNER 7000 SERIES THREE-WAY VALVES

Pipe Size (NPT)	Orifice Size (Inches)	C _v Flow Factor	Operating Pressure Differential (PSI)			Brass Pressure Vessel Catalog Number	Stainless Steel Pressure Vessel Catalog Number	Constr. Ref.
			Min	Maximum				
				AC	DC			
			10 watt	22 watt	10 watt			
1/8"	1/16	0.11	0	215	215	7131KBN1GV00		6
	3/32	0.24	0	100	100	7131KBN1LV00		6
1/4"	1/16	0.11	0	215	215	7131KBN2GV00		6
	1/16	0.11x 0.095	0	200	200		71315SN2GNJ1	7
	3/32	0.17	0	125	125		71315SN2KNJ1	7
3/8"	5/64	.17x .24	0	150	150	7131KBN2JV00		6
	3/32	0.24	0	100	100	7131KBN2LV00		6
1/2"	3/8	2.1	10	180	180	73312BN3RNJ1		9
3/4"	1/2	3.6	10	180	180	73312BN4UNJ1		9
	3/4	7.3	10	180	180	73312BN52NJ1		9

Normally Closed

Continues on next page.

SKINNER 7000 SERIES THREE-WAY VALVES

Pipe Size (NPT)	Orifice Size (Inches)	C _v Flow Factor	Operating Pressure Differential (PSI)				Brass Pressure Vessel Catalog Number	Stainless Steel Pressure Vessel Catalog Number	Constr. Ref.
			Min	Maximum					
				AC		DC			
			10 watt	22 watt	10 watt				
Normally Open									
1/8"	1/16x 1/8	0.10x 0.28	0	150		150		71395SN1GVJ1	7
	3/32x 1/8	0.17x 0.28	0	125		125		71395SN1KVJ1	7
1/4"	1/16x 1/8	0.10x 0.28	0	150		150		71395SN2GNJ1	7
	1/16x 1/8	0.10x 0.28	0	150		150		71395SN2GVJ1	7
3/8"	3/32x 1/8	0.17x 0.28	0	125		125		71395SN2KNJ1	7
	3/8	2.1	10	180		180	73322BN3RNJ1		9
1/2"	3/8	2.1	10	180		180	73382BN3RNJ1		9
	1/2	3.6	10	180		180	73322BN4UNJ1		9
3/4"	3/4	7.3	10	180		180	73322BN52NJ1		9
Multipurpose									
1/8"	1/16	0.11	0	150		150	7133KBN1GVJ1		6
	5/64	0.15	0	100		100	7133KBN1JVJ1		6
1/4"	3/64	0.052	0	180		180		71335SN2ENJ1	7
	1/16	0.095	0	115		115		71335SN2GNJ1	7
1/2"	1/16	0.11	0	150		150	7133KBN2GVJ1		6
	5/64	0.15	0	100		100	7133KBN2JVJ1		6
3/4"	3/32	0.17	0	80		80		71335SN2KNJ1	7
	3/32	0.24	0	60		60	7133KBN2LVJ1		6
All-Ports-In-Body, Normally Closed									
1/4"	1/16	0.095	0	200		200		7131TVN2GV00	10
	5/64	0.14	0	150		150		7131TVN2JV00	10
1/2"	5/6x 1/8	0.14x 0.31	0	150		150	7131TBN2JV00		11
	3/32	0.19	0	120		120		7131TVN2LV00	10
3/4"	3/32x 9/64	0.19x 0.38	0	120		120	7131TBN2LV00		11
	1/8	0.31	0	70		70		7131TVN2NV00	10
1/2"	1/4	.49x .63	0	30		30	7131TBN2RV00		11
	All-Ports-In-Body, Normally Open								
1/4"	5/32x 1/8	0.41x 0.31	0		150		7132TBN2NV00		11
All-Ports-In-Body, Multipurpose									
1/4"	1/16	0.095	0	150		150		7133TVN2GV00	10
	5/64	0.17	0	100		100	7133TBN2JV00		11
1/2"	5/64	0.18	0	100		100		7133TVN2JV00	10
	1/8	0.31	0	30		30	7133TBN2NV00		11
3/4"	1/8	0.32	0	30		30		7133TVN2NV00	10
	Normally Closed, Quick Exhaust*								
1/4"	3/32x 1/8	0.11x 0.35	0	125		125		71313SN2KNJ1	8
	1/4	0.2x 1.1	0	100		100	7131EBN2LN00		12

*The valves operate at 0 PSI, however a 2 PSI minimum pressure differential is required to actuate the pressure operated quick exhaust poppet.

Four-Way Valves

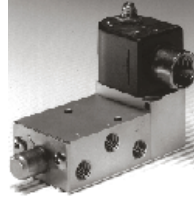

Skinner Valve

Actuation Series

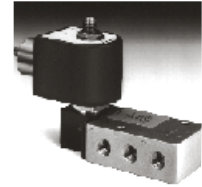

Four-Way

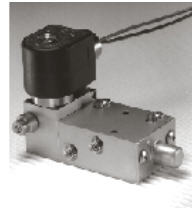

Solenoid Valves

Skinner four-way solenoid valves are ideal for use in controlling double acting, pneumatic actuators or cylinders. Two-position, single or double solenoid models are designed for long, trouble-free life, and are available in 7700 Line, 7300 Line, and standard solenoid valves.

Four-way 7700 and 7300 Line valves have many of the same standard features found in the line's three-way valves, including a unique seal, spool and cage design, integral pilot filtration and contamination tolerant design. They are available in brass or 303 stainless steel body materials. Skinner 7000 Series four-way valves are available in aluminum body material. These four-way valves have a maximum pressure differential of 150 PSI, with a C_v flow factor of 0.55 or 1.2 for 7700 and 7300 Line valves and 0.35, 1 or 1.4 for 7000 Series valves.



7700

SKINNER 7700 LINE FEATURES

Standard Features

- Unique Seal, Spool and Cage Design
- Integral Pilot Filtration
- Contamination Tolerant Design
- Integrated Main Exhaust
- Captured Exhaust Pilot
- Captured Pusher Cavity Exhaust
- Air-Assisted Spring Return
- Integral Metering
- Tag Mount Provision
- 1.5 Watt Power Level

Optional Features

- Horizontal Oriented Solenoid Operators
- Field Convertible Manual Override

SPECIFICATIONS

Mechanical Characteristics

Standard Materials of Construction

- Body—Brass or 303 Stainless Steel
- Seals—NBR
- Spool—Thermoplastic
- Cages—Thermoplastic
- Sleeve Tube—Stainless Steel (304)
- Plunger—Stainless Steel (430 FR)
- Stop—Stainless Steel (430 FR)
- Springs—Stainless Steel (18-8 or 17-4)
- Metering Stem—Stainless Steel (303)
- Shutter—Stainless Steel (303)
- Set Screw—Stainless Steel (300 Series)
- Filter—Polyethylene

Compatible Fluids

- Lubricated Air, Non-Lubricated Air, Inert Gases and other gases compatible with materials of construction.

Electrical Characteristics

Voltages

- DC—12, 24, 48
- AC—24/50/60, 110/50-120/60, 220/50-240/60
(other voltages available upon request)

Electrical Connections

- Leaded, 1/2" Conduit, DIN, Screw, Tab

Agency Approvals

- UL approvals are available on valves with applicable coil/enclosure combinations. For additional information see pages 40-41.

Miscellaneous

Minimum Ambient Temperature

- -40°F (-40°C)
Dew point must be more than 7°F below ambient.

Maximum Ambient Temperature

- 1.5 Watt AC—150°F (65°C)
- 10 Watt AC/DC—167°F (75°C)
- Fluxtron/Magnelatch—122°F (50°C)

Maximum Fluid Temperature

- 167°F (75°C)

Mounting Position

- Multipositioned—valves may be installed in any position.

SKINNER 7700 LINE FOUR-WAY VALVES

Pipe Size (NPT)	Orifice Size (Inches)	C _v Flow Factor	Operating Pressure Differential (PSI)				Brass Pressure Vessel Catalog Number	Stainless Steel Pressure Vessel Catalog Number	Constr. Ref.
			Min.	Maximum					
				AC		DC			
			1.5 watt	10 watt	10 watt				
7700 Line									
1/4"	11/64	0.55	30	150	150	150	77417BN2KN7M	77417VN2KN7M	1
	1/4	1.2	30	150	150	150	77417BN2PN7M	77417VN2PN7M	1
7700 Line—Double Solenoid									
1/4"	11/64	0.55	30	150	150	150	77477BN2KN7M	77477VN2KN7M	13
	1/4	1.2	30	150	150	150	77477BN2PN7M	77477VN2PN7M	13
7700 Line—External Pilot*									
1/4"	11/64	0.55	0	150	150	150	78417BN2KN7M	78417VN2KN7M	2
	1/4	1.2	0	150	150	150	78417BN2PN7M	78417VN2PN7M	2

* External pilot pressure to operate valve must be 30-150 PSI.

7300

SKINNER 7300 LINE FEATURES

Standard Features

- Unique Seal, Spool and Cage Design
- Integral Pilot Filtration
- Contamination Tolerant Design
- Captured Pusher Cavity Exhaust
- Air-Assisted Spring Return
- Tag Mount Provision
- 1.5 Watt Power Level

Optional Features

- Captured Exhaust Pilot
- Horizontal Oriented Solenoid Operators
- Momentary or Field Convertible Manual Overrides
- Exhaust Adaptors

SPECIFICATIONS

Mechanical Characteristics

Standard Materials of Construction

- Body—Brass or 303 Stainless Steel
- Seals—NBR
- Spool—Thermoplastic
- Cages—Thermoplastic
- Sleeve Tube—Stainless Steel (304)
- Plunger—Stainless Steel (430 FR)
- Stop—Stainless Steel (430 FR)
- Springs—Stainless Steel (18-8 or 17-4)
- Filter—Polyethylene

Compatible Fluids

- Lubricated Air, Non-Lubricated Air, Inert Gases and other gases compatible with materials of construction.

Electrical Characteristics

Voltages

- DC—12, 24, 48
- AC—24/60, 110/50-120/60, 220/50-240/60 (other voltages available upon request)

Electrical Connections

- Leaded, 1/2" Conduit, DIN, Screw, Tab

Agency Approvals

- UL approvals are available on valves with applicable coil/enclosure combinations. For additional information see pages 40-41.

Miscellaneous

Minimum Ambient Temperature

- -40°F (-40°C)
Dew point must be more than 7°F below ambient.

Maximum Ambient Temperature

- 1.5 Watt—150°F (65°C)
- 10 Watt—167°F (75°C)
- Fluxtron/Magnelatch—122°F (50°C)

Maximum Fluid Temperature

- 167°F (75°C)

Mounting Position

- Multipoised—valves may be installed in any position.

SKINNER 7300 LINE FOUR-WAY VALVES

Pipe Size (NPT)	Orifice Size (Inches)	C _v Flow Factor	Operating Pressure Differential (PSI)				Brass Pressure Vessel Catalog Number	Stainless Steel Pressure Vessel Catalog Number	Constr. Ref.	
			Min.	Maximum		DC				
				AC	DC					
			1.5 watt	10 watt	1.5 watt	10 watt				
7300 Line										
1/4"	11/64	0.55	30	150	150	150	150	73417BN2KN00	73417VN2KN00	3
	1/4	1.2	30	150	150	150	150	73417BN2PN00	73417VN2PN00	3
7300 Line—Double Solenoid										
1/4"	11/64	0.55	30	150	150	150	150	73477BN2KN00	73477VN2KN00	14
	1/4	1.2	30	150	150	150	150	73477BN2PN00	73477VN2PN00	14
7300 Line—External Pilot*										
1/4"	11/64	0.55	0	150	150	150	150	74417BN2KN00	74417VN2KN00	4
	1/4	1.2	0	150	150	150	150	74417BN2PN00	74417VN2PN00	4
7300 Line—4.0 C_v, Single Solenoid										
1/2"	5/8	4.0	30	150	150	150	150	73417BN4UN00	-	29A
7300 Line—4.0 C_v, Double Solenoid										
1/2"	5/8	4.0	30	150	150	150	150	73477BN4UN00	-	29A
7300 Line—4.0 C_v, Single Solenoid External Pilot										
1/2"	5/8	4.0	30	150	150	150	150	74417BN4UN00	-	29A
7300 Line—4.0 C_v, Single Solenoid Remote Pilot										
1/2"	5/8	4.0	30	150	150	150	150	75417BN4UN00	-	29A
Pipe Size (NPT)	Orifice Size (Inches)	C _v Flow Factor	Operating Pressure Differential (PSI)				Brass Pressure Vessel Catalog Number	Stainless Steel Pressure Vessel Catalog Number	Constr. Ref.	
			Min.	Maximum						
7300 Line—Remote Operate**										
1/4"	11/64	0.55	30	150				75417BN2KN00		5
	1/4	1.2	30	150				75417BN2PN00		5

*External pilot pressure to operate valve must be 30-150 PSI. **Remote pilot pressure to operate valve = 35 PSI+ .2 (main line pressure)

7000

SPECIFICATIONS

Mechanical Characteristics

Standard Materials of Construction

- Body—Aluminum
- Seals—NBR
- Spool—Aluminum
- Sleeve Tube—Stainless Steel (304)
- Plunger—Stainless Steel (430 FR)
- Stop—Stainless Steel (430 FR)
- Springs—Stainless Steel (18-8)
- Shading Ring—Copper

Compatible Fluids

- Lubricated Air, Non-Lubricated Air, Inert Gases

Electrical Characteristics:

Voltages

- DC—12, 24, 48
- AC—24/60, 110/50-120/60, 220/50-240/60 (other voltages available upon request)

Electrical Connections

- Leaded, 1/2" Conduit, DIN, Screw, Tab

Agency Approvals

- UL approvals are available on valves with applicable coil/enclosure combinations. For additional information see pages 40-41.

Miscellaneous

Maximum Ambient Temperature

- 10 Watt—150°F (65°C)
- Fluxtron/Magnelatch—122°F (50°C)

Mounting Position

- Multipoised—valves may be installed in any position.

Maximum Fluid Temperature

- 167°F (75°C)

SKINNER 7000 SERIES FOUR-WAY VALVES

Pipe Size (NPT)	Orifice Size (Inches)	C _v Flow Factor	Operating Pressure Differential (PSI)			Aluminum Pressure Vessel Catalog Number	Constr. Ref.
			Min.	Maximum			
				AC 10 watt	DC 10 watt		
4-Way							
1/8"	5/32	0.35	15	150	150	7341LAN1HNM0	15
1/4"	15/64	1	30	150	150	73419AN2NN00	16
	15/64	1	30	150	150	73419AN2NNM0	16
	5/16	1.4	15	150	150	7341LMN2NNM0	17

Intrinsically Safe Valves

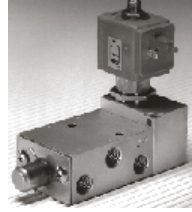

Skinner

Intrinsically Safe

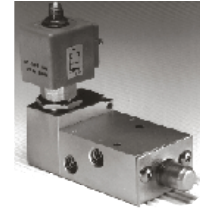

Solenoid Valves

Skinner Valve has long served industry with innovative valve solutions and safety related products. Skinner Intrinsically Safe solenoid valves are specifically designed for use in hazardous locations where fire or explosion hazards exist due to the presence of flammable gases, vapors, liquids, combustible dust, or easily ignitable fibers or flyings.

When used in conjunction with approved safety barriers, Skinner Intrinsically Safe valves have Factory Mutual Research and Canadian Standards Association approval for locations classified as Class I, Division I, Groups A, B, C, D; Class II, Division I, Groups E, F, G; and Class III, Division I. As part of an intrinsically safe system, the valves are incapable of causing explosive atmospheres to ignite by spark or thermal effect during normal operation or under fault conditions.

The three-way valves are offered as normally closed or multipurpose, while the four-way valves are two-position, single or double solenoid.

Six special purpose valves are also in our portfolio. Five designs with NAMUR interface can be mounted directly to actuators to save installation cost. ANo-Voltage-Release manual reset device is available for applications where human interaction is required to ensure the highest degree of safety.

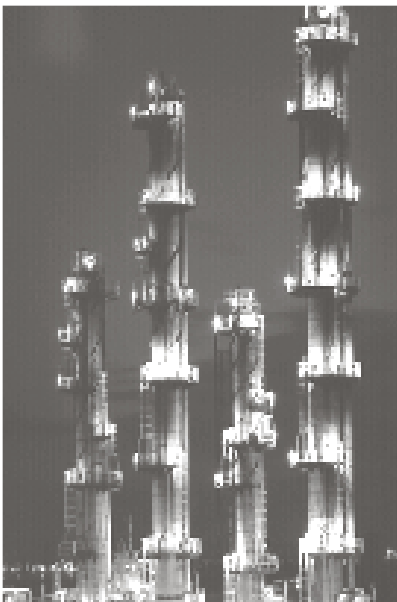

Intrinsically Safe Valves

SPECIFICATIONS

Mechanical Characteristics

Standard Materials of Construction

- Body—Brass, Stainless Steel or Aluminum
- Seals—NBR, FKM
- Spool—Thermoplastic
- Cages—Thermoplastic
- Sleeve Tube—Stainless Steel (304)
- Plunger—Stainless Steel (430 F)
- Stop—Stainless Steel (430 F)
- Springs—Stainless Steel (18-8)

Compatible Fluids

- Lubricated Air, Non-Lubricated Air, Inert Gases

Electrical Characteristics:

Agency Approvals

- FMRC and CSA approvals are available on valves with applicable coil/enclosure combinations. Valves starting with a 7, FMRC approval only.

Miscellaneous

Ambient Temperature

- -40°F to 150°F (-40°C to 65°C), see chart
Temperature ranges are dictated by the specific coil/pressure vessel combinations.

Fluid Temperature

- -40°F to 167°F (-40°C to 75°C), see chart

Mounting Position

- Multipoised—valves may be installed in any position.

SKINNER INTRINSICALLY SAFE SOLENOID VALVES

Pipe Size (NPT)	Orifice Size (Inches)	C _v Flow Factor	Operating Pressure Differential (PSI)		Ambient Temp.(F°)	Fluid Temp.(F°)	Body Material	Pressure Vessel Catalog Number	Constr. Ref.
			Minimum	Maximum					
3-Way									
1/4"	5/128	0.04	0	150	+14 to 150	+14 to 167	Brass	U131K0490	18
	5/128	0.04	0	150	+14 to 150	+14 to 167	316L S.S.	U131V5490	19
	3/64	0.06	0	100	+14 to 150	+14 to 167	Brass	U131K0890	18
	3/64	0.06	0	100	+14 to 150	+14 to 167	316L S.S.	U131V5890	19
	13/64	0.5	0	150	-13 to 150	-13 to 167	316LS.S.	U133X5196*	20
	1/4	1.2	30	150	+14 to 150	+14 to 167	Brass	73317BN2PN90	21
3-Way—4.0 C_v, Single Solenoid									
1/2"	5/8	4.0	30	150	+14 to 150	+14 to 167	Brass	73317BN4UN90	8A
	5/8	4.0	30	150	-40 to 150	-40 to 167	Brass	73317BN4U9C	8A
3-Way—Manual Reset									
1/4"	13/64	0.5	0	150	-13 to 150	-13 to 167	316L S.S.	U033X5156*	22
4-Way									
1/4"	11/64	0.55	30	150	+14 to 150	+14 to 167	Brass	73417BN2KN90	21
	11/64	0.55	30	150	+14 to 150	+14 to 167	303 S.S.	73417VN2KN90	21
	1/4	0.7	15	150	+14 to 150	+14 to 167	Alum.	U341B3490	23
	1/4	1.2	30	150	+14 to 150	+14 to 167	Brass	73417BN2PN90	21
1/2"	9/16	4	7	150	+14 to 150	+14 to 167	Alum.	U341L2190	24
4-Way—4.0 C_v, Single Solenoid									
1/2"	5/8	4.0	30	150	+14 to 150	+14 to 167	Brass	73417BN4UN90	8A
	5/8	4.0	30	150	-40 to 150	-40 to 167	Brass	73417BN4UN9C	8A
4-Way, Double Solenoid									
1/4"	11/64	0.55	30	150	+14 to 150	+14 to 167	303 S.S.	73477VN2KN90	25
	1/4	1.2	30	150	+14 to 150	+14 to 167	Brass	73477BN2PN90	25
4-Way—4.0 C_v, Double Solenoid									
1/2"	5/8	4.0	30	150	+40 to 150	+14 to 167	Brass	73477BN4UN90	8A
	5/8	4.0	30	150	-40 to 150	-40 to 167	Brass	73477BN4U9C	8A
NAMUR 3/4-Way									
1/4"	11/64	0.55	30	150	+14 to 150	+14 to 167	Alum.	73417AKDKN90	26
	1/4	1.2	30	150	+14 to 150	+14 to 167	Alum.	73417AKDPN90	26
NAMUR 3/4-Way, Double Solenoid									
1/4"	11/64	0.55	30	150	+14 to 150	+14 to 167	Alum.	73477AKDKN90	27
	1/4	1.2	30	150	+14 to 150	+14 to 167	Alum.	73477AKDPN90	27

*Requires coil 490860N7

Intrinsically Safe Solenoid Valves
 Skinner's Intrinsically Safe valve offering contains five different coil designs to allow the selection of the optimum coil configuration for the application. Each coil is built to meet NEMA4 Watertight

construction, and has a T6 temperature classification. If the use of electrical conduit is preferred, 1/2" NPT conduit hub adaptors may be ordered for field installation.

INTRINSICALLY SAFE SOLENOIDS

Solenoid Part Number	Nominal Voltage	Minimum Operating Current*	Total Solenoid Resistance	Ambient Temperature Range	Factory Mutual Entity Parameters			
					Vmax	Imax	Ci	Li
Splice Box Coil Enclosure								
490885	24 VDC	29 mA	345 Ohms	-13 to +150	30 V	100 mA	0 microF	0 mH
Potted Coil With Lead Wires								
490890	24 VDC	29 mA	345 Ohms	-13 to +150	30 V	100 mA	0 microF	0 mH
Potted Coil With DIN Connection								
490895	24 VDC	29 mA	345 Ohms	-13 to +150	30 V	100 mA	0 microF	0 mH
32mm DIN Coil And Plug Adaptor								
490880	24 VDC	35 mA	340 Ohms	-13 to +130	30 V	100 mA	0 microF	0 mH
Splice Box Coil Enclosure with Booster Circuit								
490860**	24 VDC.	60 mA	23 Ohms	-13 to +150	Loop Approval only. Consult factory.			

* These are the currents at which a complete assembly (coil and pressure vessel) will operate. ** For use on U133X5196 only.

INTRINSICALLY SAFE SOLENOIDS

Hazardous Classifications	1/2" NPT Conduit Hub Adaptor
---------------------------	------------------------------

Splice Box Coil Enclosure 490885	
Div. I; Class I, II, III; Groups A-G	U22-002
Potted Coil With Lead Wires 490890	
Div. I; Class I, II, III; Groups A-G	U22-003
Potted Coil With DIN Connection 490895	
Div. I; Class I, II, III; Groups A-G	U27-001
32mm DIN Coil And Plug Adaptor 490880 (FMRC only)	
Div. I; Class I, II, III; Groups C-G	U27-001
Splice Box Coil Enclosure with Booster Circuit 490860	
Div. I; Class I, II, III; Groups C-G	U22-001

To Order a Complete I.S. Valve:

1. Select the base valve which meets the application requirements.
2. Select the desired coil/enclosure combination.
3. Delete the first two digits of the coil part number.
4. For valves that start with a 7, add N0 to catalog number.
5. Add the remaining four digits of the coil number to the end of the base valve number.
6. Add the voltage code N7 to the number.

Ultra Low-Power Valves

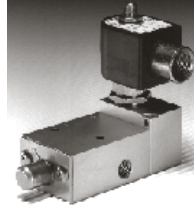

Skinner Ultra Low-Power Solenoid Valves

Skinner's Ultra Low-Power solenoid valves use a unique operator designed to keep current draw to a minimum by controlling the stroke, and conventional coil construction to achieve a power consumption level of 0.6 watts with no refresh time required. These valves are ideally suited for use in automated control systems, applications where minimizing energy consumption is critical or where heat rise in the coil must be kept to a minimum. These devices allow for an increased number of solenoids to be driven from the same power source, reducing the overall installation cost.

The coils come in an integrated design in both NEMA 4X and NEMA 4X, 7 and 9 versions.



Ultra Low-Power

SKINNER 7300 LINE FEATURES

Standard Features

- Unique Seal, Spool and Cage Design
- Integral Pilot Filtration
- Contamination Tolerant Design
- Captured Pusher Cavity Exhaust
- Air-Assisted Spring Return
- Tag Mount Provision
- 1.5 Watt Power Level

Optional Features

- Captured Exhaust Pilot
- Horizontal Oriented Solenoid Operators
- Momentary or Field Convertible Manual Overrides
- Exhaust Adaptors

SPECIFICATIONS

Mechanical Characteristics

Standard Materials of Construction

- Body—Brass or 303 Stainless Steel
- Seals—NBR
- Spool—Thermoplastic
- Cages—Thermoplastic
- Sleeve Tube—Stainless Steel (304)
- Plunger—Stainless Steel (430 F)
- Stop—Stainless Steel (430 F)
- Springs—Stainless Steel (18-8 or 17-4)
- Filter—Polyethylene

Compatible Fluids

- Lubricated Air, Non-Lubricated Air, Inert Gases and other gases compatible with materials of construction.

Electrical Characteristics

Power Consumption

- 0.6 Watts

Voltagess

- DC—12, 24, 48

Electrical Connections

- 1/2" Conduit

Agency Approvals

- UL approvals are available on valves with applicable coil/enclosure combinations. For additional information see pages 40-41.

Miscellaneous

Minimum Ambient Temperature

- +14°F(-10°C)

Dew point must be more than 7°F below ambient.

Maximum Ambient Temperature

- 140°F (60°C)

Maximum Fluid Temperature

- 167°F (75°C)

Mounting Position

- Multipositioned—valves may be installed in any position.

SKINNER ULTRA LOW-POWER VALVES

Pipe Size (NPT)	Orifice Size (Inches)	C _v Flow Factor	Operating Pressure Differential (PSI)		Brass Pressure Vessel Catalog Number	Stainless Steel Pressure Vessel Catalog Number	Constr. Ref.
			Minimum	Maximum			
3-Way							
1/4"	5/128	0.04	0	150	7131KBN2EV90	7131KVN2EV90	18/19
7300 Line—3-Way							
1/4"	11/64	0.55	30	150	73317BN2PN90	73317VN2KN90	21
	1/4	1.2	30	150			21
7300 Line 4.0 C_v, Single Solenoid							
1/2"	5/8	4.0	30	150	73317BN4UN90	-	29A
7300 Line—4-way							
1/4"	11/64	0.55	30	150	73417BN2PN90	73417VN2KN90	21
	1/4	1.2	30	150			21
7300 Line 4.0 C_v, Single Solenoid							
1/2"	5/8	4.0	30	150	73417BN4UN90	-	29A
7300 Line—4-Way, Double Solenoid							
1/4"	11/64	0.55	30	150	73477BN2PN90	73477VN2KN90	25
	1/4	1.2	30	150			25
7300 Line 4.0 C_v, Double Solenoid							
1/2"	5/8	4.0	30	150	73477BN4UN90	-	29A

Pipe Size (NPT)	Orifice Size (Inches)	C _v Flow Factor	Operating Pressure Differential (PSI)		Aluminum Pressure Vessel Catalog Number	Stainless Pressure Vessel Catalog Number	Constr. Ref.
			Minimum	Maximum			
7300 Line—4-Way, Direct Mount							
1/4"	11/64	0.55	30	150	73417AKDKN90		26
	1/4	1.2	30	150			73417AKDPN90
7300 Line—4-Way, Double Solenoid, Direct Mount							
1/4"	11/64	0.55	30	150	73477AKDKN90		27
	1/4	1.2	30	150			73477AKDPN90

Manual Reset Valves

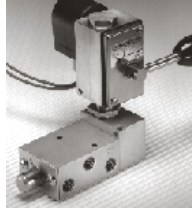

Skinner Manual Reset Solenoid Valves

Skinner Manual Reset solenoid valves are often specified when safety is the highest concern. Typical applications include chemical processing plants, oil drilling platforms, refineries, and fuel dispensing stations. These special purpose valves act as “fluid circuit breakers” in a control system.

Skinner Manual Reset valves are available in either Electrically Tripped or No-Voltage-Release models. To operate an Electrically Tripped Manual Reset valve, the coil is de-energized and the hand lever is manually moved to the latched position. The movement of the handle causes the valve to shift. When the coil is energized, the handle and latching mechanism are automatically tripped allowing the valve to return to its original position.

In the case of No-Voltage-Release Manual Reset valves, the coil is first energized and then the hand lever is manually moved to the latched position. The movement of the handle causes the valve to shift. When the coil is de-energized, the handle and latching mechanism are automatically tripped allowing the valve to return to its original position.

The three-way Manual Reset valves are offered in normally open, normally closed and multipurpose configurations. Four-way Manual Reset valves are provided with five ports for separate control of the actuator exhaust air.



Manual Reset

- Seals—NBR, FKM
- Plunger—Stainless Steel (430 FR)
- Springs—Stainless Steel
- Stop—Stainless Steel (430 FR)
- Sleeve tube—Stainless Steel (304)

Compatible Fluids

- Determined by valve selection. Most valves are compatible with inert gases, air, and petroleum products. Consult factory.

- DC—12, 24, 48

Electrical Connections

- Leaded, DIN, 1/2 conduit, Screw, Tabs

Agency Approvals

- UL approvals are available on valves with applicable coil/enclosure combinations. For additional information see pages 40-41.

Miscellaneous

Maximum Fluid Temperature

- 185°F (85°C)

Maximum Ambient Temperature

- 10 Watt—167°F (75°C)
- 22 Watt—131°F (55°C)

SPECIFICATIONS

Mechanical Characteristics

Standard Materials of Construction

- Body—Brass, Stainless Steel or Aluminum as specified
- Manual Reset Housing—Brass

Electrical Characteristics

Power Consumption

- 10 Watts—AC
- 22 Watts—DC

Voltages

- AC—24/60, 110/50-120/60, 220/50-240/60

SKINNER MANUAL RESET VALVES

Pipe Size (NPT)	Orifice Size (Inches)	C _v Flow Factor	Operating Pressure Differential (PSI)			Max Fluid Temp (°F)	No Voltage Release Pressure Vessel	Electrically Tripped Pressure Vessel
			Min	AC Max	DC Max			
3-Way Normally Closed, Brass Body, NBR Seals								
1/4"	11/64	0.55	30	150	150	165	70317BN2KNVR	70317BN2KNET
	1/4	1.2	30	150	150	165	70317BN2PNVR	70317BN2PNET
3/8"	3/8	2.1	10	180	180	185	70312BN3RNVVR	70312BN3RNET
1/2"	1/2	3.6	10	180	180	185	70312BN4UNVR	70312BN4UNET
3/4"	3/4	7.3	10	180	180	185	70312BN52NVR	70312BN52NET
3-Way Normally Closed, Stainless Steel Body, NBR Seals								
1/4"	3/64 x 3/32	0.62 x 0.17	0	200	200	185	70315SN2ENVR	70315SN2ENET
	1/8 x 3/32	0.23 x 0.17	0	200	200	185	70315SN2MNVVR	70315SN2MNET
	11/64	0.55	30	150	150	165	70317VN2KNVR	70317VN2KNET
	1/4	0.55	30	150	150	165	70317VN2PNVR	70317VN2PNET
3-Way Normally Closed, Stainless Steel Body, FKM Seals								
1/4"	1/16 x 3/32	0.11 x 0.17	0	150	150	185	70315SN2GVVVR	70315SN2GVET
	3/32 x 3/32	0.17 x 0.17	0	90	90	185	70315SN2KVVR	70315SN2KVET
3-Way Normally Open, Brass or Stainless Steel Body, NBR Seals								
1/4"	1/16 x 3/32	0.095 x 0.17	0	150	150	185	70325SN2GNVR	70325SN2GNET
3/8"	5/8	2.1	10	180	180	185	70322BN3RNVVR	70322BN3RNET
1/2"	1/2	3.6	10	180	180	185	70322BN4UNVR	70322BN4UNET
3/4"	3/4	7.3	10	180	180	185	70322BN52NVR	70322BN52NET
3-Way Universal All-Ports In Body, Brass Body, NBR Seals								
1/4"	5/64 x 5/64	0.17 x 0.17	0	100	100	185	7033TBN2JVVVR	7033TBN2JVET
	1/8 x 1/8	0.23 x 0.23	0	50	50	185	7033TBN2NVVR	7033TBN2VET
3-Way Universal All-Ports In Body, 303 Stainless Steel Body, FKM Seals**								
1/4"	1/16 x 1/16	.095 x 0.09	0	150	150	185	7033TVN2GVVVR	7033TVN2GVET
	5/64 x 5/64	0.17 x 0.17	0	100	100	185	7033TVN2JVVVR	7033TVN2JVET
	1/8 x 1/8	0.23 x 0.23	0	50	50	185	7033TVN2NVVR	7033TVN2VET
3-Way Intrinsically Safe, Stainless Steel Body, NBR Seals								
1/4"	3/16	0.63	0	145	145	135	U033X51560860N7*	
4-Way, Aluminum Body, NBR Seals								
1/4"	1/4	1	15	150	150	165	70419AN2NNVR	70419AN2NNET
4-Way, Brass Body, NBR Seals								
1/4"	11/64	0.55	30	150	150	165	70417BN2KNVR	70417BN2KNET
	1/4	1.2	30	150	150	165	70417BN2PNVR	70417BN2PNET
4-Way, Stainless Steel Body, NBR Seals								
1/4"	11/64	0.55	30	150	150	165	70417VN2KNVR	70417VN2KNET
	1/4	1.2	30	150	150	165	70417VN2PNVR	70417VN2PNET

Direct Mount (NAMUR patterned) Valves

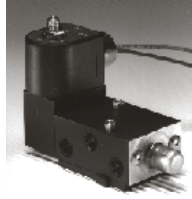

Skinner Direct Mount Solenoid Valves

For Direct-Mount solenoid valves, it is important to define the exact locations of the process connections, mounting screws, and so on, to achieve proper valve function and adequate sealing.

Increasingly, actuator manufacturers are utilizing a standardized mounting pattern referred to as the NAMUR interface. In addition to defining the critical dimensions and locations, the NAMUR interface pattern includes two M5 mounting screws, an M5 positioning stud, and two 16mm x 2mm O-rings as standard.

Three-way Skinner NAMUR valves are normally closed, direct acting models.

The four-way Skinner NAMUR valve designs have a C_V range from .55 to 1.2, and are supplied with a unique 3-way/4-way conversion plate. The user can alter the function of the valve from 4-way to 3-way simply by rotating the conversion plate 180 degrees. In the 3-way configuration, the plate channels return air from the piston side to the spring cavity of the actuator. Without this venting feature, environmental air—which is often contaminated with moisture, dust particles, or other particulates—would be drawn into the spring cavity promoting spring corrosion and premature actuator failure.



Direct Mount

SPECIFICATIONS

Mechanical Characteristics

Standard Materials of Construction

- Body—Aluminum or 303 Stainless Steel
- Seals—NBR or FKM
- Spool—Thermoplastic
- Cages—Thermoplastic
- Sleeve Tube—Stainless Steel (304)
- Plunger—Stainless Steel (430 FR)
- Stop—Stainless Steel (430 FR)
- Springs—Stainless Steel (18-8 or 17-4)
- Metering
 - Stem—Stainless Steel (303)
 - Shutter—Stainless Steel (303)
 - Set screw—Stainless Steel (300 Series)

- Filter—Polyethylene
- Plate—Thermoplastic

Compatible Fluids

- Lubricated Air, Non-Lubricated Air, Inert Gases and other gases compatible with materials of construction.

Electrical Characteristics

Voltages

- DC—12, 24, 48
- AC—24/60, 110/50-120/60, 220/50-240/60 (other voltages available upon request).

Electrical Connections

- Leaded, 1/2" Conduit, DIN, Screw, Tab

Agency Approvals

- UL approvals are available on valves with applicable coil/enclosure combinations. For additional information see pages 40-41.

Miscellaneous

Minimum Ambient Temperature

- -40°F (-40°C)
- Dew point must be more than 7°F below ambient.

Maximum Ambient Temperature

- 1.5 Watt—150°F (65°C)
- 10 Watt—167°F (75°C)
- 22 Watt—77°F (25°C)
- Fluxtron/Magnetatch—122°F (50°C)

Maximum Fluid Temperature

- 167°F (75°C)

Mounting Position

- Multipoised—valves may be installed in any position.

SKINNER DIRECT MOUNT VALVES

Pipe Size (NPT)	Orifice Size (Inches)	C _v Flow Factor	Operating Pressure Differential (PSI)						Aluminum Pressure Vessel Catalog Number	Stainless Steel Pressure Vessel Catalog Number	Constr. Ref.		
			Min.	Maximum			1.5 watt	10 watt				22 watt	
				AC	DC	DC							
3-Way													
1/4"	3/32	0.17	0		150			150		71315AKDKN00		28	
	5/64	0.14	0		150			150				7131TVKDJV00	29
	3/32	0.19	0		120			120				7131TVKDLV00	29
	1/8	0.31	0		70			70				7131TVKDNV00	29
	1/8	0.31	0				120		120			7131TVKDNVP0	29
7700 Line—3-Way/4-Way													
1/4"	11/64	0.55	30	150	150			150		77417AKDKN00	77417VKDKN00	30	
	1/4	1.2	30	150	150			150		77417AKDPN00	77417VKDPN00	30	
7700 Line—3-Way/4-Way, Double Solenoid													
1/4"	11/64	0.55	30	150	150			150		77477AKDKN00	77477VKDKN00	31	
	1/4	1.2	30	150	150			150		77477AKDPN00	77477VKDPN00	31	
7700 Line—3-Way/4-Way, External pilot													
1/4"	11/64	0.55	30	150	150			150		78417AKDKN00	78417VKDKN00	30	
	1/4	1.2	30	150	150			150		78417AKDPN00	78417VKDPN00	30	
7300 Line—3-Way/4-Way													
1/4"	11/64	0.55	30	150	150			150	150	73417AKDKN00	73417VKDKN00	32	
	1/4	1.2	30	150	150			150	150	73417AKDPN00	73417VKDPN00	32	
7300 Line—3-Way/4-Way, Double Solenoid													
1/4"	11/64	0.55	30	150	150			150	150	73477AKDKN00	73477VKDKN00	33	
	1/4	1.2	30	150	150			150	150	73477AKDPN00	73477VKDPN00	33	
7300 Line—3-Way/4-Way, External Pilot													
1/4"	11/64	0.55	30	150	150			150	150	74417AKDKN00	74417VKDKN00	32	
	1/4	1.2	30	150	150			150	150	74417AKDPN00	74417VKDPN00	32	

Coils, Options and Accessories

Accessories

Quick Exhaust Module

In many instances during the normal processing cycle, or in the event of an emergency shutdown situation, it is necessary to close the control valve very quickly. In order to close the control valve, the valve actuator must be vented and depressurized rapidly. Rather than utilizing a special purpose solenoid valve to depressurize the actuator, the Honeywell Quick Exhaust Module and a standard solenoid valve may be used.

Designed to be installed into the cylinder port of a standard 3-way valve, the Quick Exhaust Module increases the exhaust flow to 1.1 C_v. The Module may be ordered in either brass, part number **QEXH2B**, or stainless steel construction, part number **QEXH2V**.

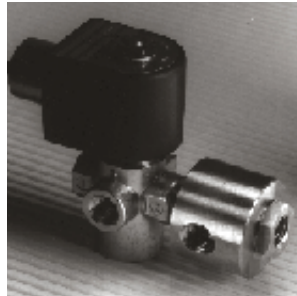

7700 Line Convertible Manual Override

This device will allow you to change the valve to a latching or momentary manual override in the field. This manual override can be installed in any of the 7700 Line products that has a 7M in positions 11 & 12 of the part number. Part number **MNVRO1**.

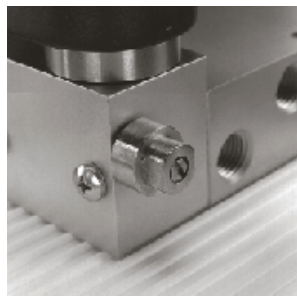

7700 Line Manual Override Plug

This accessory will replace the convertible manual override in the field, removing the manual override option from the valve. This plug can be installed in any of the 7700 Line products that has an M0 in positions 11 & 12 of the part number. Part number **MNVRO2**.

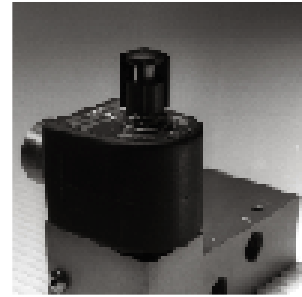

Pilot Guard

The Pilot Guard uses a polyethylene filter to prevent ambient contamination from entering the valve through the sleeve. Part number **MECH7L**.

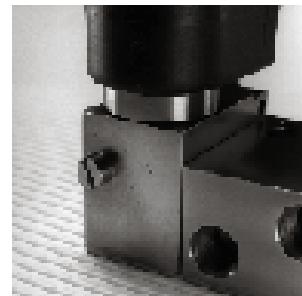

Universal Mounting Bracket

For side mounting options when equipping valves with ordinary location integrated coils. This bracket is installed on the sleeve before the coil. When the coil retention nut is tightened, the bracket is automatically secured. Note: for use on valves with 1/4" or smaller pipe connections Available as an enclosure (code NB) on fully assembled valves, or as an accessory item(7NB).

Body mounting options are also available on specific valve families. A listing is provided below:

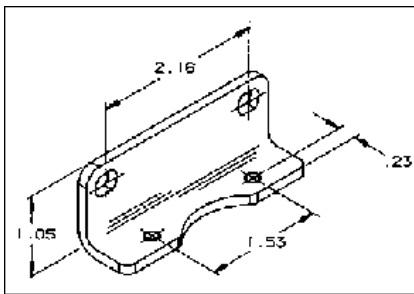

B2: For the "2" family valves with 3/8" or 1/2" NPT connections.

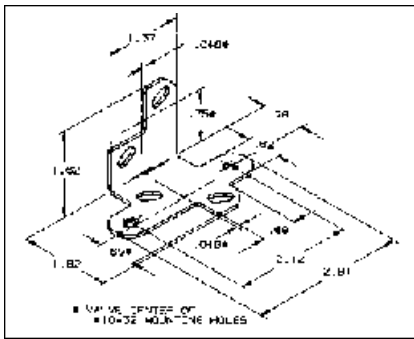

B5: For the "5" family, this bracket allows two different body mounting configurations.

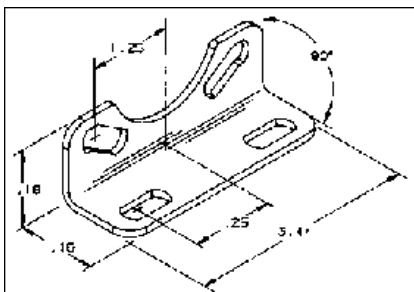

B8: For the "8" family, this bracket provides a flexible side mounting alternative.

Flow Control Valves

For pipe mounted solenoid valves, either of the NPT metering valves can be used. They are designed to enable the captured pusher cavity exhaust feature to function properly. When used, the flow control valve slows down the flow of air out of the exhaust ports of the solenoid valve without restricting the flow of the exhaust of the pusher cavity through port #3.

Part Number U08-009 (1/4" NPT)
Part Number U08-012 (1/2" NPT)



Metering Plate

For NAMUR direct mount valves, the metering plate (U40-015) is used. It is assembled between the actuator and the plastic transition plate that is shipped with the solenoid valve. The flow control is accomplished by adjusting either or both of the metering plate screws using an ordinary screwdriver.

Wrench Nut

A Wrench Nut (part number U99-011) is available to assist with removal of sleeve assemblies when performing product maintenance and repair.

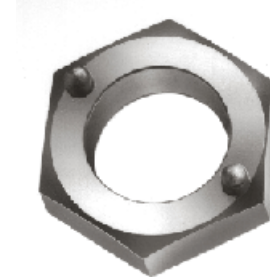

Exhaust Nut Adaptor

Allows easy piping of the sleeve exhaust port by converting the connection to either a 1/8" or 1/4" NPT pipe thread.

EXHAUST ADAPTOR NUT		
Part Number	Port Size (NPT)	Seal Material
ADAP1N	1/8"	NBR
ADAP1V	1/8"	FKM
ADAP2N	1/4"	NBR
ADAP2V	1/4"	FKM

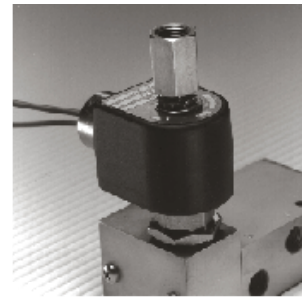

Coil Selections

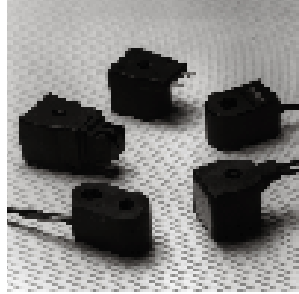

Coils are electrical devices that produce magnetic flux when electrical power is supplied to the windings. The magnetic flux, in turn, produces an attraction force which is used to operate the solenoid valve. Depending on the coil voltage and power rating, the pressure rating of a valve can vary. Valve pressure ratings are provided in each catalog section.

Skinner coils include integrated coils with a variety of termination options including: Lead Wires; 1/2" Conduit Connections; DIN Terminations; Screw terminals; and Tab connections. Specialty coils such as the Fluxtron and Magnelatch coils are also available. Additional coils for Intrinsically Safe valves are provided in the specific technical section.

Leaded Terminations

Molded with an internal yoke and 18-inch leads.

L111 Class F, 10 Watt

L222 Class H, 10 Watt

L322 Class H, 22 Watt

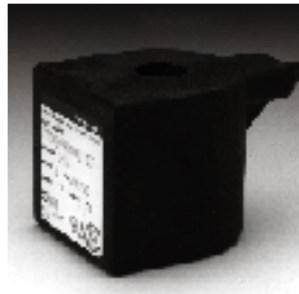

Integrated Coil Descriptions

1/2-inch Conduit Terminations

Molded with a conduit boss and 18-inch leads. Available for ordinary location and hazardous location requirements.

C111 Class F, 10 Watt Ordinary Location

C222 Class H, 10 Watt Ordinary Location

C322 Class H, 22 Watt Ordinary Location

H111 Class F, 10 Watt Hazardous Location

H222 Class H, 10 Watt Hazardous Location

H322 Class H, 22 Watt Hazardous Location

H1S1 Class F, 10 Watt Hazardous Location

H2S1 Class H, 10 Watt Hazardous Location

H3S1 Class H, 22 Watt Hazardous Location

H6S1 Class F, 1.5 Watt Hazardous Location

H7S1 Class F, 0.6 Watt Hazardous Location

C611 Class F, 1.5 Watt Hazardous Location

H611 Class F, 1.5 Watt Hazardous Location

C711 Class F, 0.6 Watt Ordinary Location

H711 Class F, 0.6 Watt Hazardous Location



DIN Terminations

Molded with standard connection per DIN 43650 A. Available with cable gland and 1/2-inch conduit connectors.

D100 Class F, 10 Watt

D200 Class H, 10 Watt

D300 Class H, 22 Watt



Screw Terminations

Molded with Screw terminals. Also available with an optional junction box for easy installation. See 7000 Series Electrical Options.

- S100** Class F, 10 Watt
- S200** Class H, 10 Watt
- S300** Class H, 22 Watt



Fluxtron Electronic Coils

Molded with a built-in electronic power control circuit that reduces the holding power level to about 1 watt, Fluxtron coils are equipped with 18-inch leads, and are available in two unique varieties: two-wire and four-wire for direct interface with isolated TTL logic level control inputs.

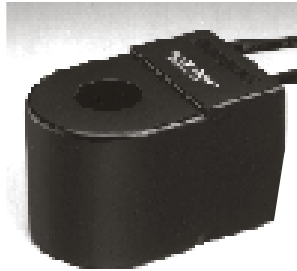

Pressure Ratings

Valve pressure ratings are provided for each applicable wattage associated with our integrated and conventional coil offering. When ordering specialty coils, the following pressure rating rules apply:

For Fluxtron Coils: Valves equipped with AC Voltage Specific coils receive the same pressure rating as a 10 Watt AC coil. DC Voltage Specific coils receive the same pressure rating as a 10 Watt DC coil.

For Magnelatch Coils: Valves equipped with Magnelatch coils receive the same pressure rating as a valve with a 10 Watt coil.

Tab Terminations

Molded with 1/4-inch wide tab terminals for female tab connections.

- T100** Class F, 10 Watt

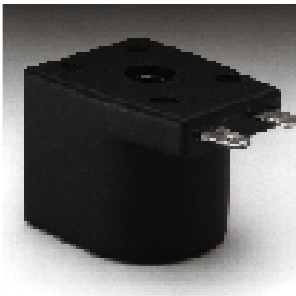

Magnelatch Latching Coils

Magnelatch Latching Coils are equipped with permanent magnets to retain plunger position after power is completely removed from the coil. Magnelatch coils use very little average power and have no appreciable temperature rise.

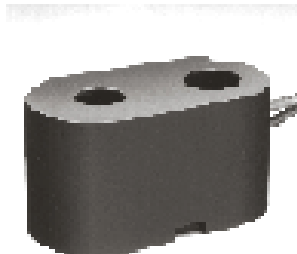

INTEGRATED AND MAGNELATCH LATCHING COIL VOLTAGES

DC Voltages	Voltage Code
12 VDC*	C1
24 VDC*	C2
48 VDC	C4
125 VDC	3N
AC Voltages	Voltage Code
24V/60HZ*	B2
120V/60HZ-110V/50HZ*	P3
240V/60HZ-220V/50HZ*	Q3
480V/60HZ-440V/50HZ	Q8

FLUXTRON ELECTRONIC COIL VOLTAGES

Voltages*	Voltage Code
12 VDC	C1
24 VDC	C2
48 VDC	C4
120 VDC	C6
24V/50-60HZ	P0
110V-120V, 50/60HZ	2W
220V-240V, 50/60HZ	3W

*Other coil voltages available upon request, consult Skinner Valve.

The voltages identified in the table above carry agency approvals for integrated coils. See pages 40-41 for additional information.
 *Magnelatch Latching Coil Voltages. Other coil voltages available upon request, consult Skinner Valve.

INTEGRATED COIL OFFERING

Coil Code	Type of Termination	Holding Power	Coil Description
L111	Leads	10 W	Class F Molded with 18" leads
L222	Leads	10 W	Class H Molded with 18" leads
L322	Leads	22 W	Class H Molded with 18" leads
C111	1/2" NPT Conduit	10 W	Class F Molded; NEMA 1, 2, 3, 3S, 4, 4X; 18" Lead wires
C222	1/2" NPT Conduit	10 W	Class H Molded; NEMA 1, 2, 3, 3S, 4, 4X; 18" Lead wires
C322	1/2" NPT Conduit	22 W	Class H Molded; NEMA 1, 2, 3, 3S, 4, 4X; 18" Lead wires
C611	1/2" NPT Conduit	1.5 W	Class F Molded; NEMA 1, 2, 3, 3S, 4, 4X; 18" Lead wires
C711	1/2" NPT Conduit	0.6 W	Class F Molded; NEMA 1, 2, 3, 3S, 4, 4X; 18" Lead wires
D100	DIN	10 W	Class F Molded
D200	DIN	10 W	Class H Molded
D300	DIN	22 W	Class H Molded
H111	1/2" NPT Conduit	10 W	Class F Molded; NEMA 3, 3S, 4, 4X, 7, 9; 18" Lead wires
H222	1/2" NPT Conduit	10 W	Class H Molded; NEMA 3, 3S, 4, 4X, 7, 9; 18" Lead wires
H322	1/2" NPT Conduit	22 W	Class H Molded; NEMA 3, 3S, 4, 4X, 7, 9; 18" Lead wires
H611	1/2" NPT Conduit	1.5 W	Class F Molded; NEMA 3, 3S, 4, 4X, 7, 9; 18" Lead wires
H711	1/2" NPT Conduit	0.6 W	Class F Molded; NEMA 3, 3S, 4, 4X, 7, 9; 18" Lead wires
H1S1	1/2" Conduit Stainless	10 W	Class F Molded; NEMA 3, 3S, 4, 4X, 7, 9; 18" Leads Stainless Steel
H2S1	1/2" Conduit Stainless	10 W	Class H Molded; NEMA 3, 3S, 4, 4X, 7, 9; 18" Leads Stainless Steel
H3S1	1/2" Conduit Stainless	22 W	Class H Molded; NEMA 3, 3S, 4, 4X, 7, 9; 18" Leads Stainless Steel
H6S1	1/2" Conduit Stainless	1.5 W	Class F Molded; NEMA 3, 3S, 4, 4X, 7, 9; 18" Leads Stainless Steel
H7S1	1/2" Conduit Stainless	0.6 W	Class F Molded; NEMA 3, 3S, 4, 4X, 7, 9; 18" Leads Stainless Steel
S100	Screw	10 W	Class F Molded
S200	Screw	10 W	Class H Molded
S300	Screw	22 W	Class H Molded
T100	1/4" Tab	10 W	Class F Molded

CENELEC APPROVED COILS

HZ09	3-Wire Cable Gland	10 W	EEx d IIC T4 (IP 65)	Molded Class F, LCIE 96.D6196X, Internal and External Grounding, Cable Length: 1500mm
HZ10	3-Wire Cable Gland	10 W	EEx m II T6 (IP 65)	Molded Class H, LCIE 97.D6126X, Internal and External Grounding, Cable Length: 1500mm
HZ11	3-Wire Cable Gland	22 W	EEx m II T6 (IP 65)	Molded Class H, LCIE 97.D6126X, Internal and External Grounding, Cable Length: 1500mm
HZ12	3-Wire Cable Gland	1.5 W	EEx m II T6 (IP 65)	Molded Class F, LCIE 97.D6129X, Internal and External Grounding, Cable Length: 1500mm
HZ13	3-Wire Cable Gland	0.6 W	EEx m II T6 (IP 65)	Molded Class F, LCIE 97.D6129X, Internal and External Grounding, Cable Length: 1500mm
HZ06	Cable Connection	8 W	EEx me II T3/T4 (IP 65)	LCIE 92.6036X, Reinforced plastic housing, rectified diodes and varistor protection are encapsulated, screw termination in terminal box
VZ03	Cable Connection	AC: 11 W DC: 9 W	EEx e II T4 (IP 67)	LCIE 86.6161X, Metal housing with encapsulated screw terminal coil, internal and external ground screws

SPECIALTY COILS*

J611	Lead Wires	1 W		2-wire, Voltage Specific, Fluxtron Electronic Coil
F611	Lead Wires	1 W		4-wire, Voltage Specific, TTL Logic Level Compatible, Fluxtron Electronic Coil
J011	Lead Wires	0 W		2-wire, Magnelatch Coil, DC Service only
G011	Lead Wires	0 W		3-wire, Magnelatch Coil, AC or DC Service

* These coils require separate enclosures. See the Enclosure Selection Chart.

Fluxtron and Magnelatch Enclosure Selections

Acoil enclosure is necessary for both Fluxtron Electronic and Magnelatch Latching coils. An enclosure serves as a flux path for Fluxtron coils, and can also serve to protect the coil and provide a

means for accommodating the electrical connections. The following enclosure selection is provided to complement the integrated coil offering, and to give customers the utmost flexibility in product type and installation.

The following enclosures are available:

Enclosures

A0: Has a 7/8-inch exit hole to accommodate a strain relief, conduit adaptor or other fitting.

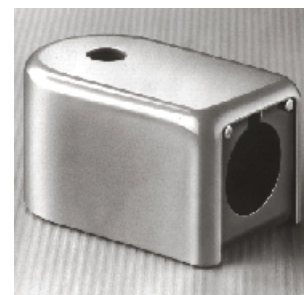

B0: Has a 1/2-inch NPT thread for attachment of conduit, 1/2-inch NPT fitting or 1/2-inch BX cable.

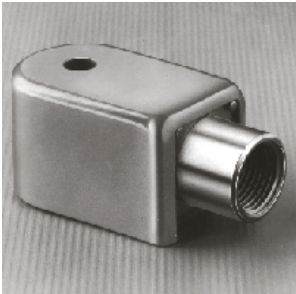

F0: Ayoke. Provides no additional protection from the environment, but merely completes the magnetic flux path.

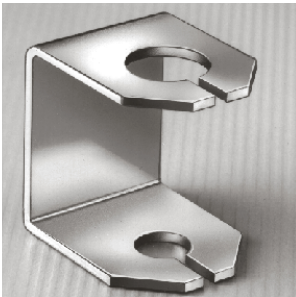

G0: A 1/2-inch NPT hub designed to conform to watertight standards. Can accommodate conduit, 1/2-inch NPT fitting or 1/2-inch BX cable.

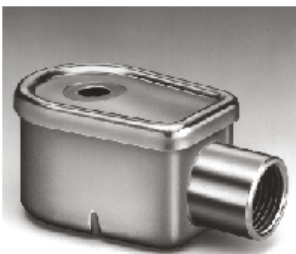

J0: Has a 7/8-inch exit hole and is built to allow an internal splice.

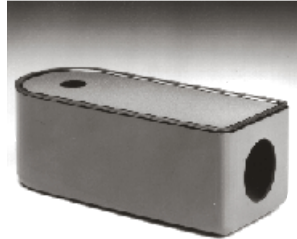

M1: For Magnelatch Latching coils only, a 1/2-inch NPT hub for attachment of conduit, 1/2-inch NPT fitting or 1/2-inch BX cable.

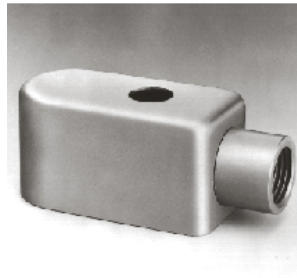

M2: For Magnelatch Latching coils only, leads exit from the enclosure through a grommet.

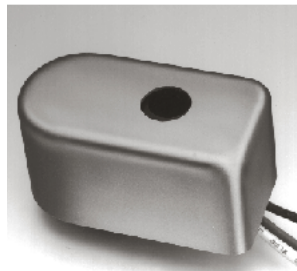

Mechanical Options

Solenoid valves at times require a variety of different mechanical options to meet the specific needs of a given application. Many of these options have become common over time, others are specified infrequently.

Skinner has the ability to produce wide varieties and combinations of mechanical options. Listed are only a few of the common options we provide. If the option (or set of options) you need is not listed, please contact a company representative for assistance.

Available options are denoted by the valve family to which they pertain. The family designator is position 5 of the pressure vessel number. To order the listed mechanical options:

1. Select the base pressure vessel number. It must have "00" in the last two digits.
2. Confirm compatibility of the option with the Mechanical Options Table.
3. Write the mechanical option code in place of the last two digits of the pressure vessel number. For example, a 7133TBN2JV00 with a manual override (MO) becomes 7133TBN2JVM0.

FLUXTRON ELECTRONIC AND MAGNELATCH ENCLOSURE SELECTIONS

Enclosure Code	Description
Fluxtron Enclosures	
A0	Standard Connection, 7/8" exit for lead wires, NEMA 1
B0	Conduit Connection, 1/2" NPT conduit hub, NEMA 1
F0	Yoke
G0	Watertight, 1/2" NPT conduit hub, NEMA 4X
J0	Splice Box, allows for internal splice, NEMA 1
Magnelatch Enclosures	
M1	Magnelatch, 1/2" NPT conduit hub, NEMA 1
M2	Magnelatch, leaded with grommet connection, NEMA 1

VALVE ACTUATION SERIES MECHANICAL OPTIONS

Code	Mechanical Option	Applicable Valve Family (Pressure Vessel 5th Digit)										
		2	3	5	6	7	8	9	L	K	T	
A2	Silver Shading Ring	X	X	X	X		X					
J0	Pilot Exhaust Return Pipe	X										
J1	Exhaust Adaptor Nut	X	X	X				X		X		
M0	Manual Override			X								X
M0	Field Convertible Manual Override				X	X						
M5	M0 with Exhaust Adaptor Nut			X				X				
R0	Metering Exhaust		X	X								
R1	Main Stream Metering		X	X								
R2	Adjustable Bypass			X								
7A	Momentary Manual Override				X	X						
7C	7Awith J1				X	X						
7F	Captured Exhaust Pilot					X						
7G	7F with 7A					X						
7H	7F with M0					X						

Electrical Options

The following is a description of common options available with Valve Actuation Series coils. To order a coil with an option write the electrical option code in place of the last two digits of the coil code. These electrical options (with exception of the ground lead) are also available for sale as individual pieces (accessories). For an accessory simply order the code.

Descriptions of Electrical Options

Option Code GL: Integrated Coils with a conduit termination are available for both ordinary and hazardous location

installations. Each coil type can be provided with an 18-inch ground lead.



Option Code D1: This DIN plug is equipped with a cable gland which acts as a strain relief when tightened. Within the plug are screw terminals to which the control wires are fastened. The plug provides for a

ground connection and may be assembled to the valve at 90° intervals. Service can be performed quickly by simply unplugging the coil. An electrician is not required. The plug comes complete with a gasket to meet NEMA specification Type 4.



Option Code D2: This DIN plug is identical to the cable gland version except that a 1/2-inch NPT conduit thread replaces the cable gland. It is ideal for attachment of flexible conduit.



Option Codes DB, TB: This option consists of a terminal box for both the screw and DIN model integrated coils. It is designed to meet NEMA Type 4, 4X standards when installed. It is provided with a 1/2-inch NPT conduit thread and ground screw.



ELECTRICAL OPTIONS

Coil Option		Applicable Coils	
Code	Description	Coil Types	Coil Codes
GL	Ground Lead	Conduit Terminated	C1GL, C2GL, C3GL, H1GL, H2GL, H3GL
D1	Cable Gland DIN Plug	DIN	D1D1, D2D1, D3D1
D2	1/2" Conduit DIN Plug	DIN	D1D2, D2D2, D3D2
DB*	Terminal Box	DIN	D1DB, D2DB, D3DB,
TB*	Terminal Box	Screw Terminal	S1TB, S2TB, S3TB

*Meets NEMA Type 4, 4X when connected to a Screw Terminal or DIN Terminal Coil, as applicable.

Valve Ordering

There are six different product categories that can be ordered from this catalog. The product categories are:

Item	Description
1	Fully assembled valves with integrated coils
2	Fully assembled valves with conventional coils and enclosures
3	Pressure Vessels only
4	Integrated Coils only
5	Coils/Enclosure Assemblies
6	Accessories

Ordering Items 1 and 2, Fully Assembled Valves

Step 1: Select the appropriate Pressure Vessel.

Step 2: Use the Mechanical Options Table, if required, to write the option code in place of the last two pressure vessel digits, “00”.

Step 3: Select the appropriate integrated coil and enclosure (NO), or enclosure and conventional coil.

Step 4: Use the Electrical Options Table, if required, to write the option code in place of the last two coil digits.

Step 5: Use the Voltage Code to specify the correct voltage for the valve.

Pressure Vessel	Enclosure	Coil	Voltage Code
7131KBN2GV00	+ NO	+ C111	+ P3
7131KBN2GV00NOC111P3			

Ordering Items 3 and 4, Pressure Vessels, Integrated Coils

Pressure Vessels can be ordered as separate items. Simply select the catalog number and submit the order. If a mechanical option is desired, make sure it is included in place of the last two “00” digits in the pressure vessel number.

Integrated Coils can be ordered as separate items. Simply select the coil number and add the correct voltage code. If an electrical option is desired, make sure that it is included in place of the last two digits in the coil number, then specify the voltage by its code.

Example: Select integrated coil “C111” for a 120-60–110-50 AC voltage, the number to order this coil then becomes “C111P3”.

Ordering Item 5, Coil/Enclosure Assemblies

Step 1: Select the appropriate enclosure.

Step 2: Select the appropriate coil.

Step 3: Determine the correct voltage code.

Enclosure	Coil	Voltage Code
G0	+ F611	+ C2
G0F611C2 = NEMA4X, Fluxtron 4 wire TTL compatible design, 24VDC		

Ordering Item 6, Accessories

Accessories can be purchased by simply specifying the part number listed with the accessories. If an enclosure or electrical option is being purchased as a separate item (as an accessory) select the option number and place the order.

Example: To buy a 1/2” conduit DIN plug (electrical option code D2) as a separate accessory simply order “ELECD2”.

Ordering Products Not Listed in the Catalog

When an application demands a product with a combination of features not listed in the catalog, use the significant numbering system to specify the exact valve needed. Skinner Valve personnel will then assist in determining the applicability, availability and price for the new product.

Example: A7133TBN2JV00 with BSP porting can be requested by asking for a 7133TBG2JV00. In this example the N (for NPT) was substituted with a G (for BSP) in the valve number.

If an application requires combinations of options not listed in the catalog, contact the Skinner Valve Product Application Center at 203 827-2300 for a valve number and pricing.

For information on ordering Intrinsically Safe Valves, please refer to pages 18 and 19.

Valve Numbering

Skinner Actuation Series Numbering System

All Skinner Valve Actuation Series 3- and 4-way solenoid valves, along with our Direct Mount, Manual Reset and Ultra Low-Power valves, follow a 20-digit significant numbering system. This system allows the user an easy method to select and identify the product. Please note that some Skinner Intrinsicly Safe valves have a different numbering system.

Provided below is a complete set of numbering system codes. The codes apply to three major valve components; the pressure vessel, the enclosure, and the coil.

77317BN2KN00

SKINNER VALVE ACTUATION SERIES PART NUMBERING SYSTEM						
1	2	3	4	5	6	7
	Actuation	Type	Flow Pattern	Family	Body Material	Connection
7	0–Manual Reset 1–Direct Operated 3–Pilot Operated, Internal Pilot Supply 4–Pilot Operated , External Pilot Supply 5–Remote Pressure Operated 7–7700 Line, Pilot Operated, Internal Pilot Supply 8–7700 Line, Pilot Operated, External Pilot Supply	3–Three-Way 4–Four-Way	3-Way Valves 1–Normally Closed 2–Normally Open: pressure in body 3–Multipurpose 8–Diverting 9–Normally Open: pressure in sleeve 4-Way Valves 1–2-position, single operator, monostable 7–2-position, dual operator, bistable	2 3 5 6 7 9 E K L T X	A–Aluminum B–Brass S–430F SS V–303 SS M–Zinc alloy	N–NPT G–BSP PL K–Direct Mount P–NPTF

75317BN2KN00

SKINNER VALVE ACTUATION SERIES PART NUMBERING SYSTEM

8	9	10	11 & 12	13 & 14
Pipe Size	Orifice/Cv/Flow	Seals	Mechanical Options	Enclosure Options
For N, G, or P in Position 7: 1-1/8" 2-1/4" 3-3/8" 4-1/2" 5-3/4" For K in Position 7: D-NAMUR	A through H J through N P through V 0 through 9	N-NBR V-FKM	00-No Option M0-Manual Override* J1-Exhaust Adaptor Nut M5-MO & J1 ET-Electrically Tripped Manual Reset VR-No-Voltage-Release Manual Reset 7A-Momentary Manual Override 7C-7A& J1 7F-Captured Exhaust Pilot 7G-7F & 7A 7H-7F & M0 7M-Plugged Manual Override	A0-7/8" Knock Out B0-1/2" Conduit F0-Yoke G0-Watertight J0-Junction Box M1-Magnelatch 1/2" Conduit M2-Magnelatch Grommet N0-Nut & Washer for Integrated Coils

*Field Convertible with 6 or 7 in position 5.

SKINNER VALVE ACTUATION SERIES PART NUMBERING SYSTEM

15 & 16	17 & 18	19 & 20
Coil Type	Terminations	Voltage
Integrated Coils C1-1/2" NPT conduit, 10 Watt, Class F, NEMA 4X C2-1/2" NPT conduit, 10 Watt, Class H, NEMA4X C3-1/2" NPT conduit, 22 Watt, Class H, NEMA4X C6-1/2" NPT conduit, 1.5 Watt, Class F, NEMA 4X C7-1/2" NPT conduit, 0.6 Watt, Class F, NEMA4X D1-DIN, 10 Watt, Class F D2-DIN, 10 Watt, Class H D3-DIN, 22 Watt, Class H H1-1/2" NPT conduit, 10 Watt, Class F, NEMA 4X, 7, 9 H2-1/2" NPT conduit, 10 Watt, Class H, NEMA4X, 7, 9 H3-1/2" NPT conduit, 22 Watt, Class H, NEMA4X, 7, 9 H6-1/2" NPT conduit, 1.5 Watt, Class F, NEMA4X, 7, 9 H7-1/2" NPT conduit, 0.6 Watt, Class F, NEMA 4X, 7, 9 L1-18" leads, 10 Watt, Class F L2-18" leads, 10 Watt, Class H L3-18" leads, 22 Watt, Class H S1-Screw Terminal, 10 Watt, Class F S2-Screw Terminal, 10 Watt, Class H S3-Screw Terminal, 22 Watt, Class H T1-1/4" Tab Terminal, 10 Watt, Class F Specialty Coils F6-Fluxtron, 4-wire, 1 Watt J6-Fluxtron, 2-wire, 1 Watt J7-Fluxtron, 2-wire, 2 Watt J0-Magnelatch, 2-wire, DC service only G0-Magnelatch, 3-wire, AC or DC service	00-Standard DIN (No lead wires) 11-Class F coils, 18" lead wires 22-Class H coils, 18" lead wires GL-Ground wire for C1, C2, C3, H1, H2, & H3 coils D1-D1 coils with cable gland connector D2-D1 coils with 1/2" conduit connector DB-D1 coils with terminal box TB-S1, S2, S3 Coils with Terminal Box	Integrated & Magnelatch Coils* B2-24/60* C1-12 VDC* C2-24 VDC* C4-48 VDC 3N-125 VDC P3-120/60, 110/50* Q3-240/60, 220/50* Q8-480/60, 440/50 Fluxtron Coils C1-12 VDC C2-24 VDC C4-48 VDC C6-120 VDC P0-24/50-60 2W-110-120, 50/60 3W-220-240, 50/60

Additional Technical Information

Introduction

Solenoid valves are highly engineered products which can be utilized in many diverse and unique fluid system applications. In addition to operational functionality, selecting the best product for a given application must also consider safety, reliability, media compatibility and suitability for the operating environment. This section provides a brief overview of the components and functional varieties of solenoid valves available from Parker's Skinner Valve. A more detailed and complete discussion on solenoid valve technology is provided in the Skinner Valve Technical Reference Manual.

General Information

Valve Construction and Basic Operation

A solenoid valve is operated by opening or closing an orifice in the valve body which permits or prevents flow through the valve. The orifice is opened or closed through the use of a plunger that is raised and lowered within a sleeve tube by energizing a solenoid. The bottom and/or top of the plunger contain a seal which closes the orifice in the body or the stop respectively.

The solenoid assembly consists of a coil, plunger and sleeve assembly. In a normally closed valve a plunger return spring holds the plunger against the orifice preventing flow through the valve. When current flows through the coil, a magnetic field is produced which attracts the magnetic plunger. This action compresses the return spring, allows the body orifice to open and permits fluid to flow through the valve.

Effective operation of a solenoid valve is dependent upon the efficiency of the magnetic circuit through which the flux travels. If the flux path is designed with a high level of magnetic efficiency, (i.e., with low magnetic resistance), the level of available magnetic force is improved. This is accomplished by the use of magnetically highly conductive materials throughout the circuit.

Pressure Vessel

The combination of a body, sleeve assembly and plunger make a pressure vessel. The pressure vessel is the device that contains the process fluid.

The body of a valve contains the inlet and outlet ports, and is the part through which flow passes when a valve is open. For most valves the fluid passes through an orifice, which is opened and closed as a result of plunger actuation.

Coils are rated by insulation classes that correspond to a maximum allowable coil temperature. The maximum allowable coil temperature is the temperature to which the coil can be exposed without experiencing thermal degradation of the magnet wire insulation. These classes and corresponding maximum temperature levels are:

Class	Nominal Class Temperature	Permissible Temp. by Change of Resistance Method (UL)	Temp. Rise Above 25°C (77°F) Ambient Temp.
A	105°C (221°F)	110°C (230°F)	85°C (185°F)
B	130°C (266°F)	120°C (248°F)	95°C (203°F)
F	155°C (311°F)	140°C (284°F)	115°C (239°F)
H	180°C (356°F)	160°C (320°F)	135°C (275°F)

Coils meeting Classes F and H are sometimes referred to as “High Temperature Coils.” These ratings are summarized graphically in Figure 1.

Solenoid valves are available in a wide variety of body materials. Brass, stainless steel and aluminum are some of the materials from which most valve bodies are made. The material for any given application is generally dictated by the operating environment, the process fluid and economics.

The sleeve assembly consists of three parts—the flange, tube and stop. The flange and stop are made of magnetic material to contain and direct magnetic flux through the plunger. The tube is made of non-magnetic material to make certain that the magnetic field is directed through the plunger rather than around it.

Since the inside surface of the sleeve assembly contacts the process fluid, it is subjected to the same line pressure as the valve body. To provide the required strength and integrity, Skinner utilizes a welded sleeve assembly.

The plunger is the element that opens and closes a valve. Several different plunger configurations have been developed to support the wide variety of solenoid valve designs required to fill the needs of our customers.

Plunger seals may be also made from a variety of materials. Seal material selection depends on the particular process fluid, fluid temperature, operating pressure differential, leakage rate and cycle life requirements. Typical seal materials are NBR, FKM and EPDM.

Skinner Valve plunger assemblies, when appropriate, use floating top and bottom seals to enhance valve performance. These seals permit the plunger to generate a larger actuation force to open against the pressure differential in the valve. This enables the valve to operate at higher pressure ratings.

Coils And Enclosures

Solenoid valve coils are the heart of the operating mechanism of a valve. A coil is a component of an electromagnet which, when supplied with an electric current (AC or DC), produces a magnetic field. This generates a magnetic force that attracts the plunger.

Solenoid valve coil enclosures perform three important functions. The enclosure is necessary to complete the magnetic flux path of the solenoid, provide protection from contact with the coil and protect the coil against environmental conditions. The coil enclosure may also provide a means for accommodating a variety of electrical connections. Skinner Valve offers enclosures of various types to suit most applications.

To properly size a valve for air or gas service, four specific parameters must be known:

- *Upstream pressure (inlet pressure to the valve)*
- *Pressure differential (or downstream pressure, the outlet pressure of the valve)*
- *Required flow through the valve in SCFM*
- *The type of gas that will be flowing through the valve and its specific gravity*

With these parameters known, refer to chart (1) or (2). These charts provide flow (in SCFM) for a valve operating on air with a C_V Factor of 1. The charts contain identical information, but chart (2) should be used for valves with lower flows.

Steps to Determine Flow:

1. *Locate the downstream pressure (outlet pressure, or upstream pressure minus the pressure differential) on the bottom scale of the chart.*
2. *Read vertically up the chart until the downstream pressure intersects the upstream pressure (represented by a family of curved lines).*
3. *Read horizontally across the graph to the intersection with the left scale, "Flow in SCFM @ 70°F." The value indicated at this point on the scale is the flow of air through a valve with a C_V of 1.*
- 4a. *To determine the flow of a gas other than air at 70°F, use the correction factors listed below, (Air Flow x Correction Factor = Gas Flow). If the correction factor is not known it can be calculated by using the specific gravity of the gas in the following equation:*

Correction Factor = 1/(the square root of specific gravity)

Argon	0.85	Nitrogen	1.02	Methane	1.34
Hydrogen	3.79	Oxygen	0.95		

- 4b. *To determine the C_V of the valve which will have the required flow, simply divide the required flow rate by the above flow for a C_V of 1. For example if an air flow of 150 SCFM was found from the graph and the required flow is 450 SCFM, choose a valve with a C_V equal to 450/150, or 3.*

Valve Sizing— Determining the Flow Rate of a Valve

Air and Gas Service

SEAL MATERIAL DESIGNATIONS FOR ALL SKINNER PRODUCTS

ASTM Designations

NBR
EPDM
FKM

Commercial Designations and/or Trade Names

Buna-N, Nitrile
Ethylene Propylene
Fluorinated Hydrocarbon, Viton®

Viton® is a DuPont Co. trademark.

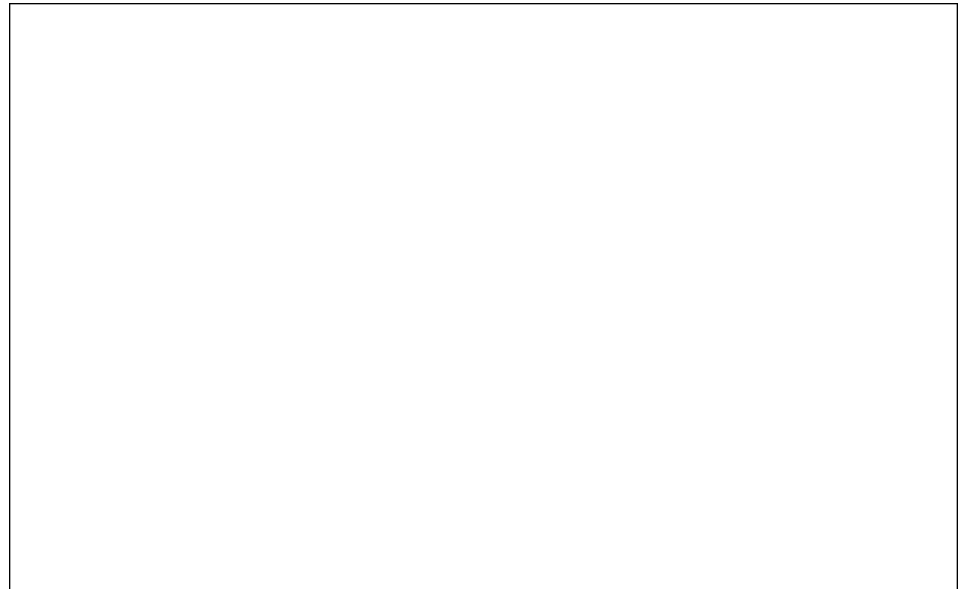

3-Way Normally Closed Solenoid Valve

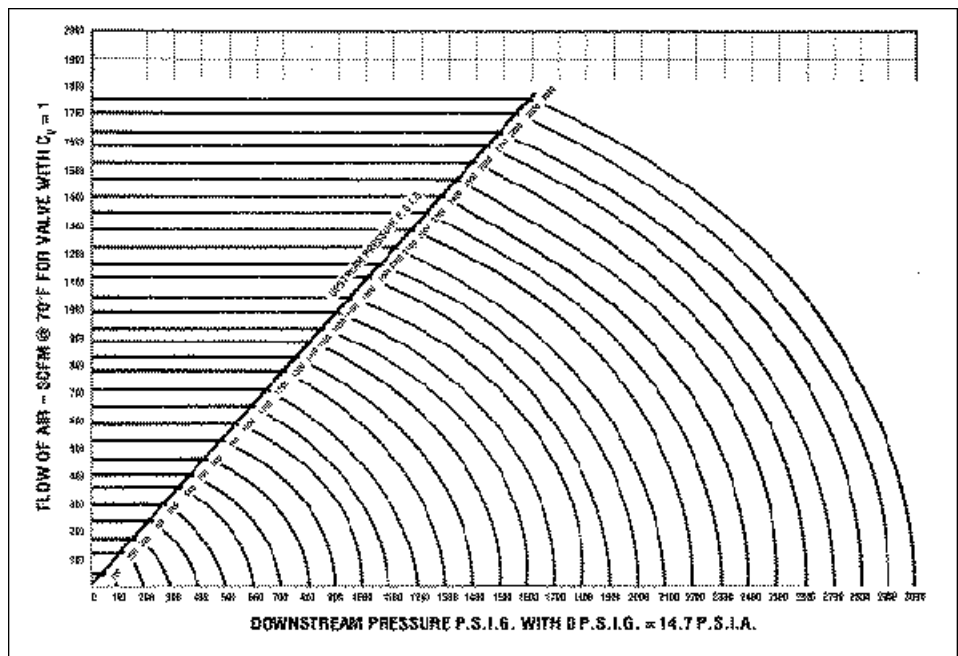

Chart 1

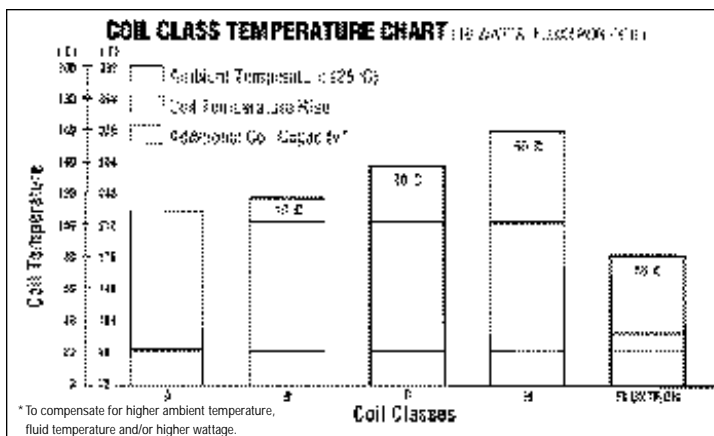

Figure 1

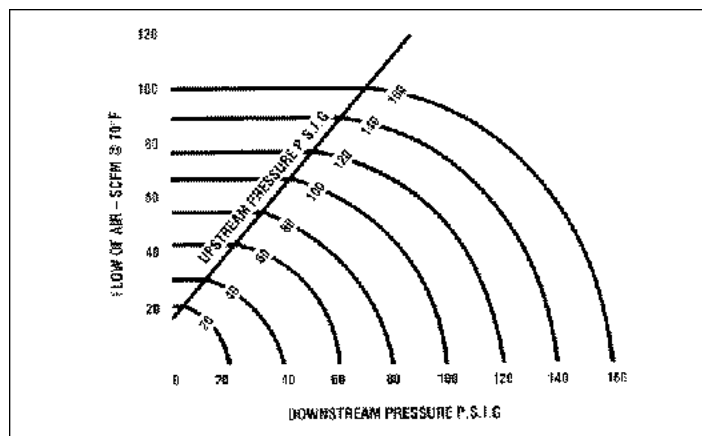

Chart 2

AGENCY APPROVED SOLENOID VALVE COMBINATIONS

The table below summarizes the specific approvals obtained, which are dependent upon the combination of approved pressure vessels, coils and enclosures for both ordinary and hazardous locations.

Enclosure Code	Coil* Type/Option	Metallic Bodied Pressure Vessels** (Aluminum, Brass, Stainless Steel, Zinc)		
		NPT Ported	BSP Ported	Direct Mounted
N0	C111, C222, C322	UL Listed		
N0	C611, C711			
N0	C1GL, C2GL, C3GL			
N0	D1DB, D2DB, D3DB			
N0	D4DB, D5DB			
A0, B0, G0, J0	F611, J611			
N0	H111, H222, H322			
N0	H611, H711			
N0	H1GL, H2GL, H3GL			
N0	S1TB, S2TB, S3TB			
N0	D100, D1D1, D1D2	UL Component Recognized		
N0	D200, D2D1, D2D2			
N0	D300, D3D1, D3D2			
F0	F611, J611			
N0	L111, L222, L322			
N0	S100, S200, S300			
N0	T00			

UL approved valves are also CSA certified. **NOTE: Agency approval is contingent upon factory assembly of solenoid valves.**

*Coil voltage must also be approved. See page 29. **Pressure vessels must be approved as General Purpose (GP) valves.

Vacuum

While many of our solenoid valves with elastomeric seals listed in this catalog can be used on vacuum, the standard 100% production leakage test does not ascertain that the valves are sufficiently tight for severe vacuum applications. We do, however, design, produce, and test many vacuum valves to meet specific customer requirements. Therefore, we invite you to consult us for your vacuum valve applications.

Fluid Temperature Limitations

32°F Minimum Fluid Temperature if moisture is present. Otherwise, minus 40°F for direct operated valves with NBR seals, minus 10°F with FKM seals (minus 10°F for "4" family valves.) For exceptions, consult Skinner.

RESPONSE TIME

The response time of a solenoid valve depends on many factors such as voltage, frequency, pressure, media, temperature (including coil) and the type of valve. Variations in these factors can have a significant effect on the response time. The following tabulation lists the approximate response times for several different types of valves. The times given are for the valves to go from closed position to open or from open position to closed.

Valve Type	Response Time (milliseconds)
Direct Operated Valves	4-15
Small Pilot Operated Piston Valves	30-90
Large Pilot Operated Piston Valves	100-150
Small Pilot Operated Diaphragm Valves	30-60
Large Pilot Operated Diaphragm Valves	60-160
Direct Lift Diaphragm Valves	30-60

OPERATING SPEED (CYCLE RATES)

Operating speed is defined as the maximum number of cycles (On/Off) per minute that the solenoid valve is capable of completing. It is dependent upon the response time characteristics of the valve. Many of our small, short stroke, direct acting valves are capable of operating at rates over 2,000 cycles per minute. However, for normal operation, lower cycle rates as shown are usually recommended.

Valve Type	Up to (cycles/min.)
Direct Operated Valves	600
Small Pilot Operated Piston Valves	400
Large Pilot Operated Piston Valves	150
Small Pilot Operated Diaphragm Valves	300
Large Pilot Operated Diaphragm Valves	200
Direct Lift Diaphragm Valves	200

CURRENT DRAIN

For Integrated Coils: To determine the approximate Holding or Inrush Current for 24/60, 120/60, 240/60 and 480/60 volts in amperes, divide the voltage into the "VA" value indicated for each valve type in the table below.

Valve Type	AC Power Consumption					
	1.5 Watt Integrated Coils		10 Watt Integrated Coils		22 Watt Integrated Coils	
	VA Holding	VA Inrush	VA Holding	VA Inrush	VA Holding	VA Inrush
Manual Reset						
70312 E.T.	—	—	16	31	—	—
70312 N.V.R.	—	—	20	32	—	—
70315 E.T.	—	—	16	31	—	—
70315 N.V.R.	—	—	20	32	—	—
70317 E.T.	—	—	16	31	—	—
70317 N.V.R.	—	—	20	32	—	—
70322 E.T.	—	—	16	31	—	—
70322 N.V.R.	—	—	20	32	—	—
70325 E.T.	—	—	16	31	—	—
70325 N.V.R.	—	—	20	32	—	—
7033TE.T.	—	—	16	31	—	—
7033TN.V.R.	—	—	20	32	—	—
70417 E.T.	—	—	16	31	—	—
70417 N.V.R.	—	—	20	32	—	—
70419 E.T.	—	—	16	31	—	—
70419 N.V.R.	—	—	20	32	—	—
3-Way						
73312	—	—	17	27	—	—
71313	—	—	17	27	—	—
71315	—	—	17	27	—	—
7131E	—	—	17	31	—	—
7131K	—	—	17	31	—	—
7131T	—	—	17	35	35	57
7132E	—	—	20	32	—	—
7132T	—	—	17	35	35	57
7133K	—	—	17	31	—	—
71335	—	—	17	27	—	—
7133T	—	—	17	35	—	—
71395	—	—	17	27	—	—
73317	2.1	2.1	17	27	—	—
73322	—	—	17	27	—	—
73382	—	—	17	27	—	—
77317	2.1	2.1	—	—	—	—
4-Way						
73417	2.1	2.1	17	27	—	—
73477	2.1	2.1	17	27	—	—
73419	—	—	17	27	—	—
7341L	—	—	17	31	—	—
77417	2.1	2.1	—	—	—	—
77477	2.1	2.1	—	—	—	—

DC HOLDING CURRENT (AMPERES)

Coil Type	Power Level	12 Volt	24 Volt	48 Volt
Integrated	0.6 Watt	0.05	0.025	0.013
Integrated	1.5 Watt	0.13	0.063	0.031
Integrated	10 Watt	0.81	0.41	0.2
DIN	10 Watt	0.81	0.41	0.2
Integrated	22 Watt	1.64	0.83	—

For Fluxtron and Magnelatch specialty coils, consult Honeywell for holding and inrush current values.

PORT MARKINGS

Valve Type	Port Identification			ANSI Symbol
	Pressure	Cylinder	Exhaust	
3-Way, Normally Closed				
71313	1	2	3	1
71315	1	2	3	1
7131E	1	2	3	2
7131K	2	1	0	3
7131T	1	2	3	1
73312	1	2	3	11
73317	1	2	3	3
73317BN2PN7F	1	2	3	4
74317	1	2	3	5
75317	1	2	3	6
77317	1	2	3	7
78317	1	2	3	8
3-Way, Normally Open				
7132T	3	2	1	9
71395	3	2	1	9
73322	3	2	1	10
73382	2	3	1	11
3-Way, Multipurpose				
71335		Pressure can be applied to any port.		13
7133K		Pressure can be applied to any port.		13
7133T		Pressure can be applied to any port.		13
4-Way				
73417	1	2, 4	3, 5	15
73417BN7F	1	2, 4	3, 5	15
73419	P	A, B	EA, EB	16
7341LAN	1	2, 4	3, 5	17
7341LMN	1	2, 4	3, 5	18
73477	1	2, 4	3, 5	19
73477BN7F	1	2, 4	3, 5	20
74417	1	2, 4	3, 5	21
75417	1	2, 4	3, 5	22
77417	1	2, 4	3, 5	23
77477	1	2, 4	3, 5	24
78417	1	2, 4	3, 5	25
Intrinsically Safe				
U131K	2	1	0	3
U131V	1	2	0	26
U133X	Pressure can be applied at any port.			12
73317	1	2	3	3
U033X	Pressure can be applied at any port.			–
73417	1	2, 4	3, 5	15
U341B	1	2, 4	3	27
U341L	P	B, A	S, R	28
73477	1	2, 4	3, 5	19
Ultra-Low Power				
U131K	2	1	0	3
U131V	1	2	0	4
73317	1	2	3	3
73417	1	2, 4	3, 5	15
73477	1	2, 4	3, 5	19
U033X	Pressure can be applied at any port.			–
78417	1	2, 4	3, 5	25

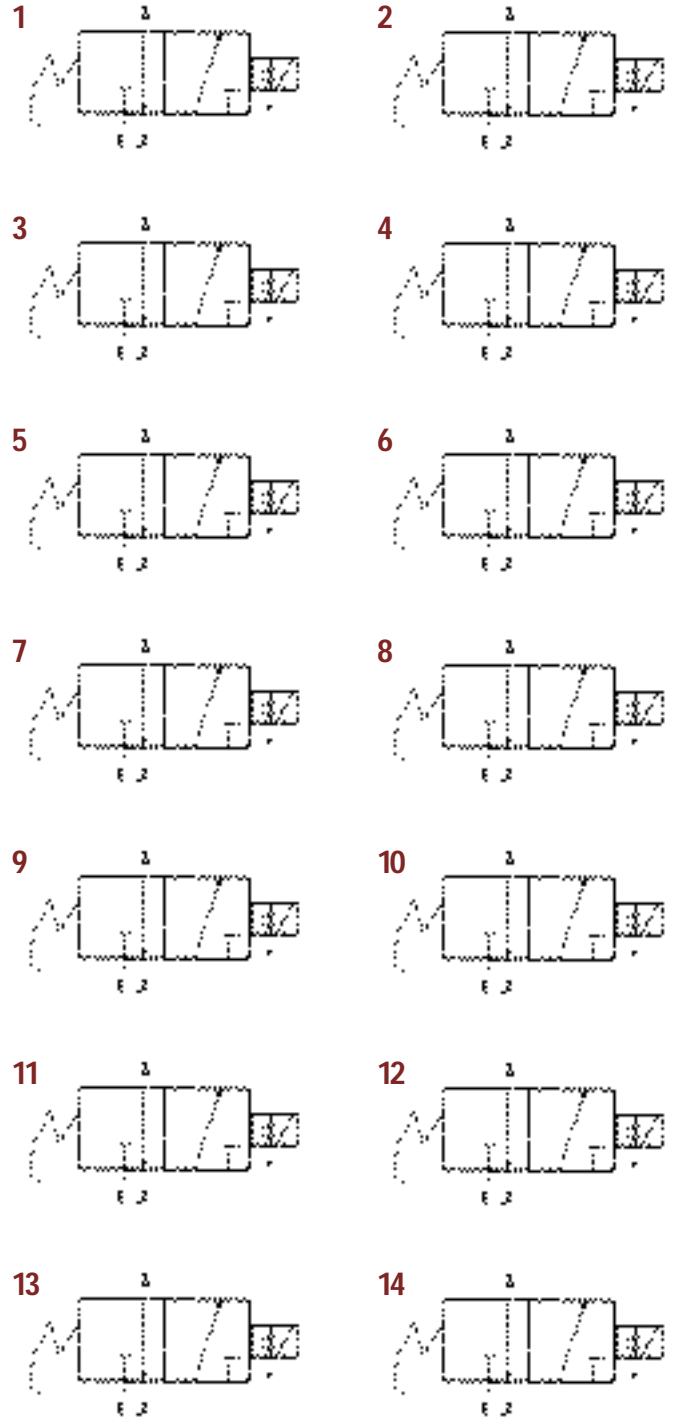

PORT MARKINGS

Valve Type	Port Identification			ANSI Symbol
	Pressure	Cylinder	Exhaust	
Manual Reset				
70312	1	2	3	—
70315	1	2	3	—
70317	1	2	3	—
70322	3	2	1	—
70325	2	1	3	—
7033T	Pressure can be applied at any port.			13
70417	1	2, 3	4, 5	—
70419	P	A, B	EA, EB	—
U033X	Pressure can be applied at any port.			—
Direct Mount				
71315	1	2	3	1
7131T	1	2	3	1
73417	1	2, 4	3, 5	15
73477	1	2, 4	3, 5	19
74417	1	2, 4	3, 5	21
77417	1	2, 4	3, 5	23
77477	1	2, 4	3, 5	24
78417	1	2, 4	3, 5	25

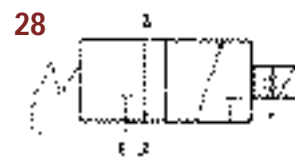
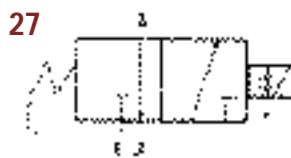
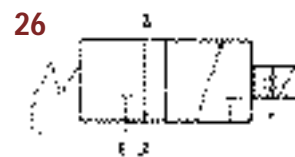
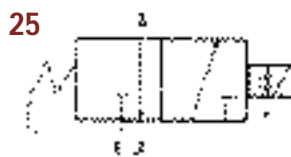
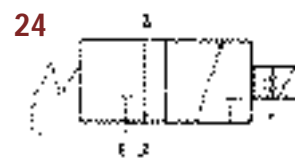
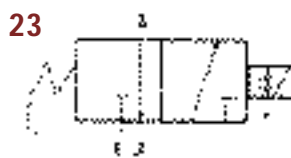
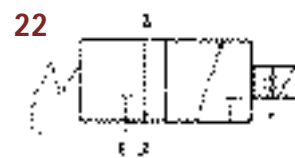
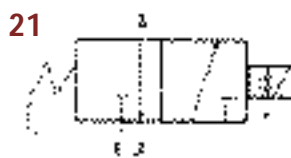
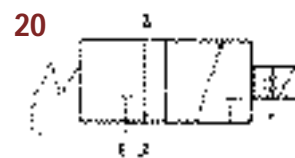
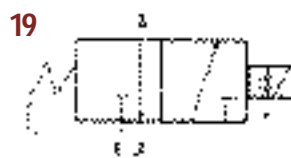
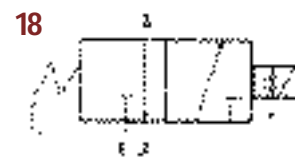
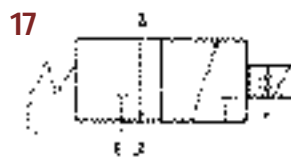
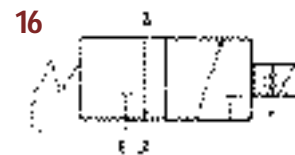
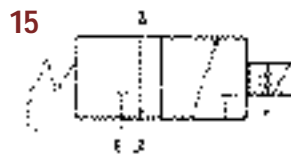

Construction References

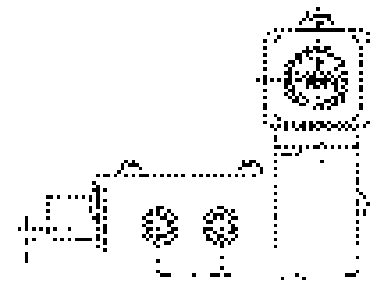
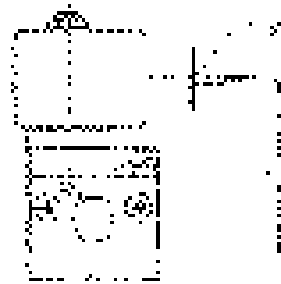
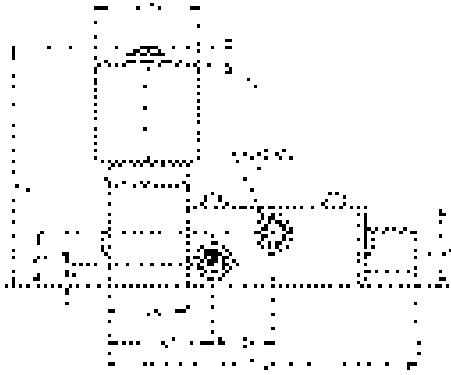
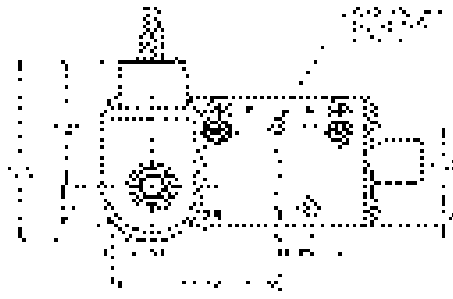

Construction Reference 1

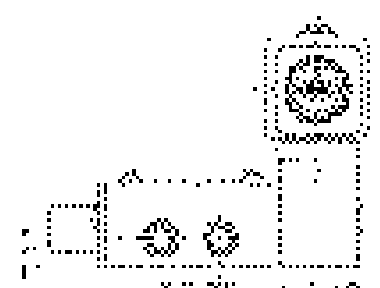
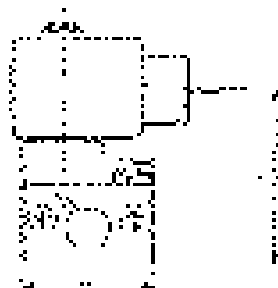
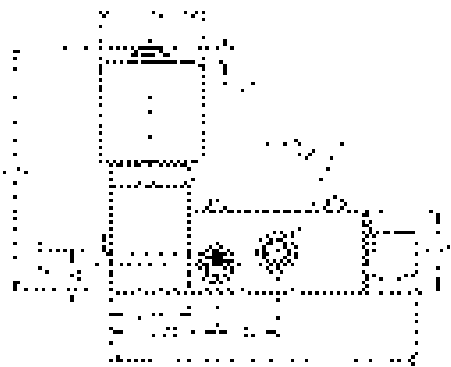
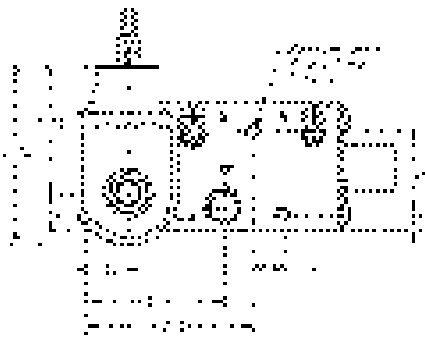

Construction Reference 2

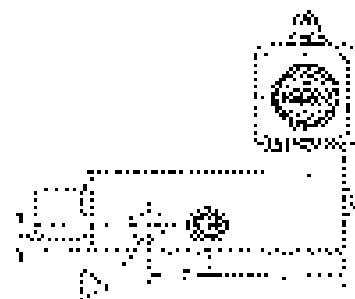
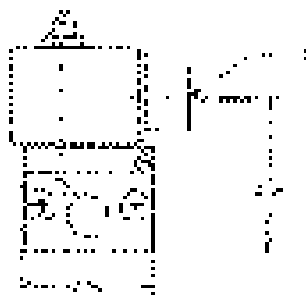
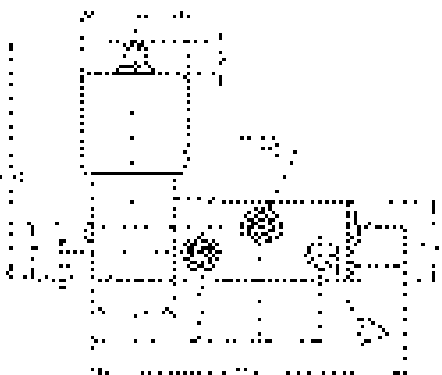
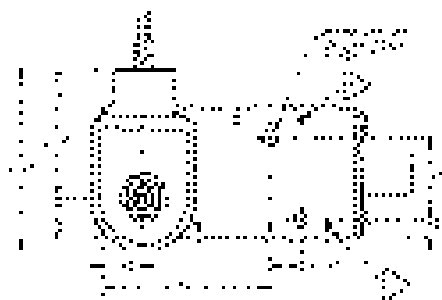

Construction Reference 3

▶ For 4-way valve only.

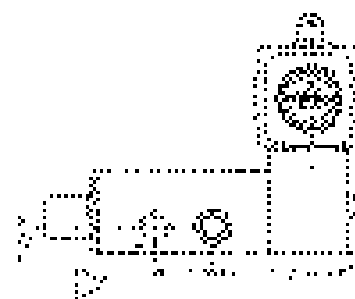
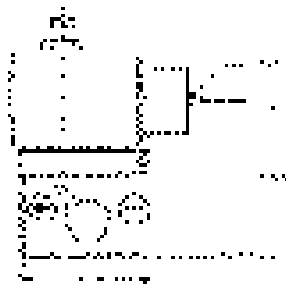
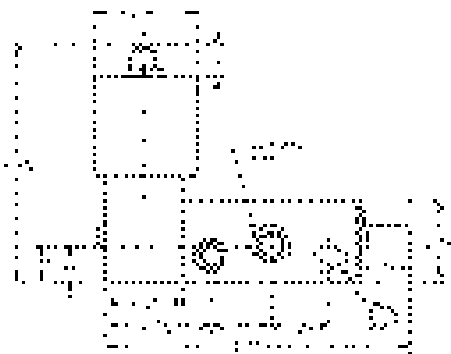
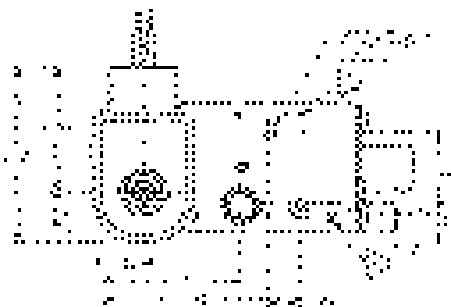

Construction Reference 4

▶ For 4-way valve only.

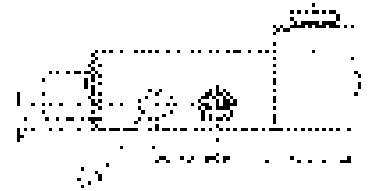
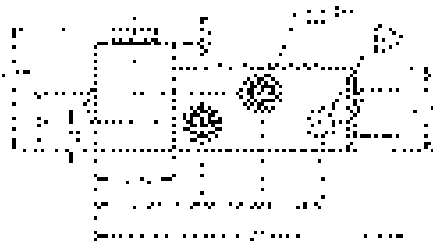
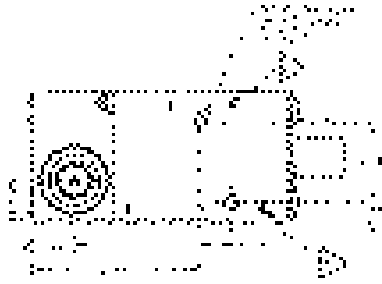

Construction Reference 5

▶ For 4-way valve only.

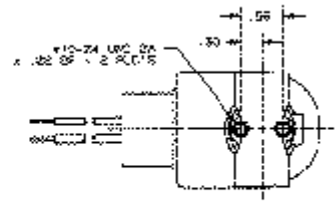
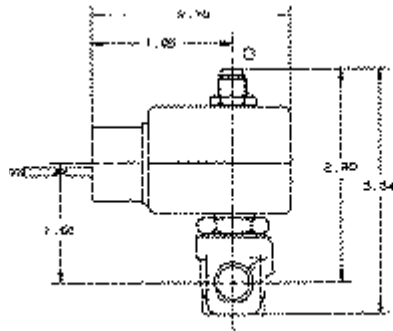
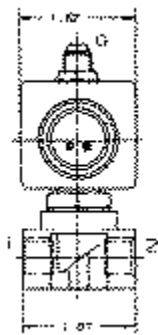

Construction Reference 6

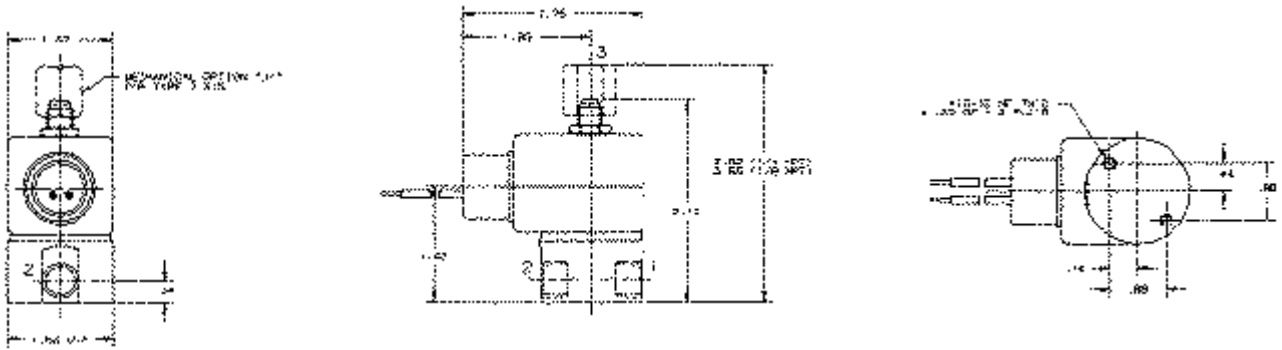

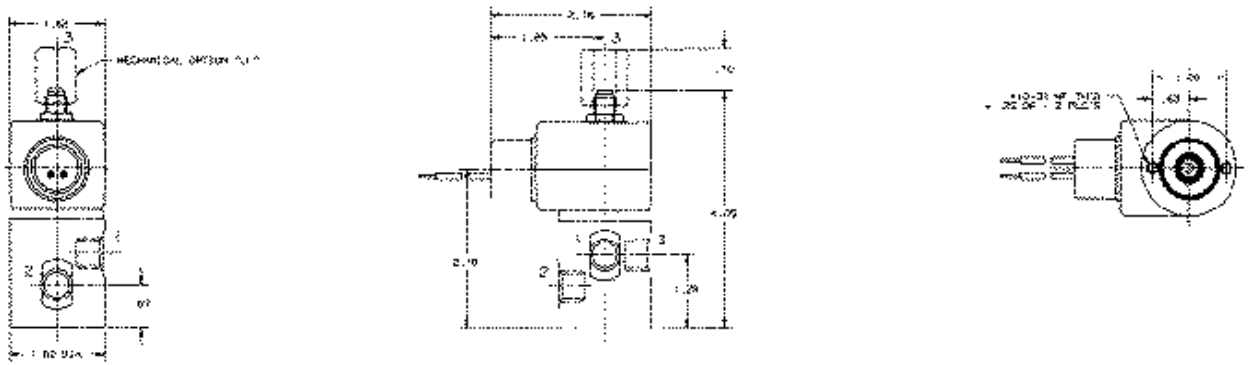

Construction Reference 7

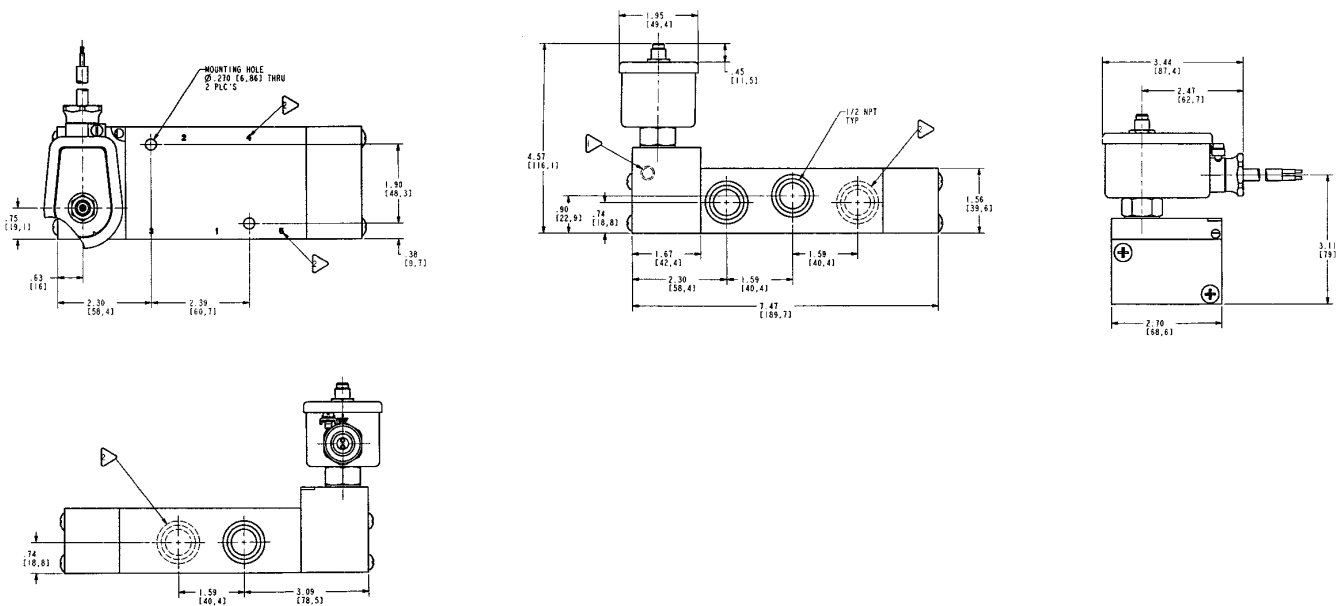

Construction Reference 8



Construction Reference 8A

 Ports 4 and 5 apply to 4-Way valve only.
 Manual override mechanical option.

Dimension										
Valve	H	P	C	L	W	S	T	R	J	K
73312BN3RNJ1	4.89	3.98	1.96	2.97	2.62	0.65	0.59	1.44	1.22	0.91
73312BN4UNJ1	5.10	4.08	2.08	3.38	3.09	0.78	0.69	1.66	1.41	1.06
73312BN52NJ1	6.07	4.34	2.34	4.22	3.38	1.03	0.86	1.69	1.72	1.39
73322BN3RNJ1	4.89	3.98	1.96	2.97	2.62	0.65	0.59	1.44	1.22	0.91
73382BN3RNJ1	4.89	3.98	1.96	2.97	2.62	0.65	0.59	1.44	1.22	0.91
73322BN4UNJ1	5.10	4.08	2.08	3.38	3.09	0.78	0.69	1.66	1.41	1.06
73322BN52NJ1	6.07	4.34	2.34	4.22	3.38	1.03	0.86	1.69	1.72	1.39

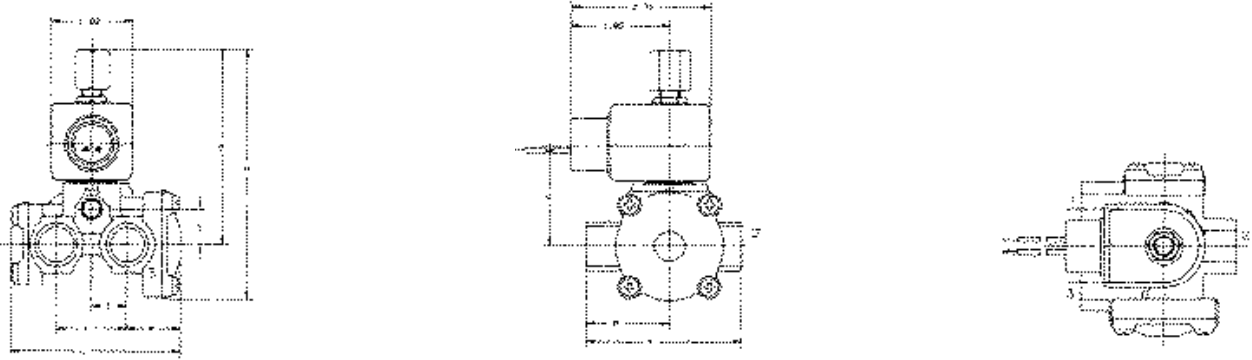

Construction Reference 9

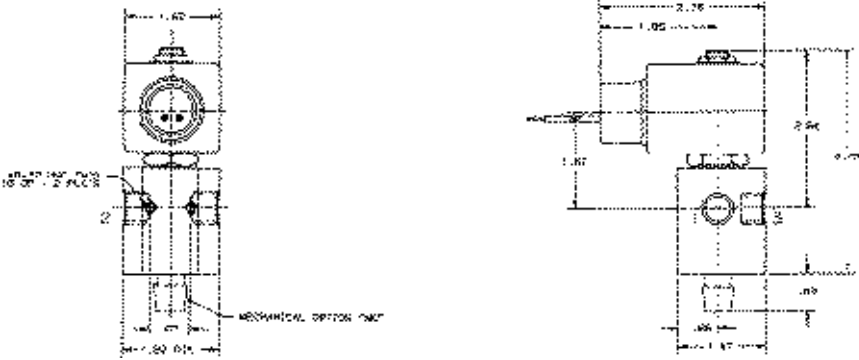

Construction Reference 10

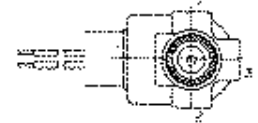
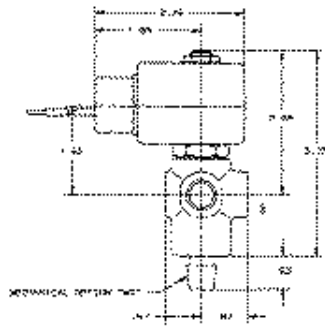
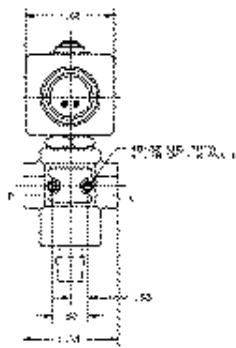

Construction Reference 11

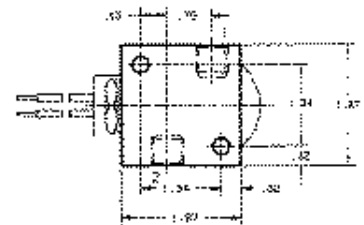
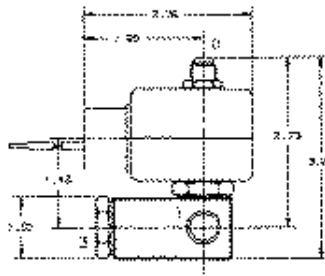
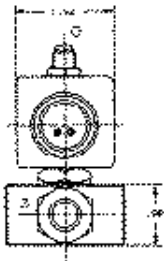

Construction Reference 12

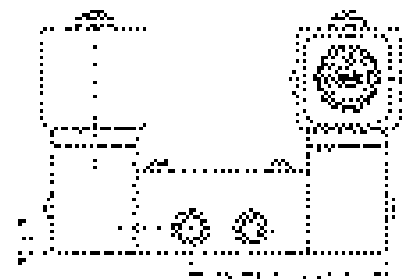
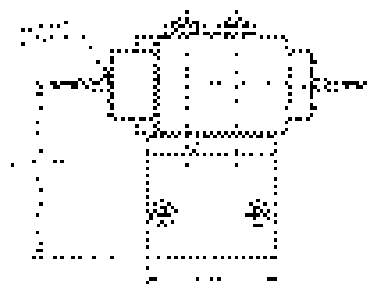
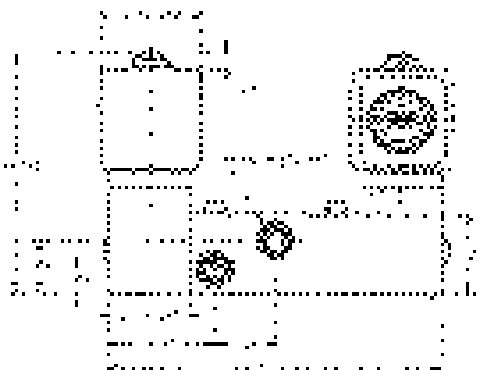
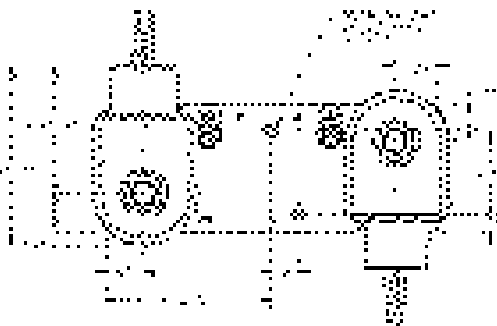

Construction Reference 13

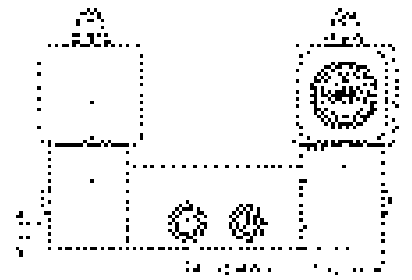
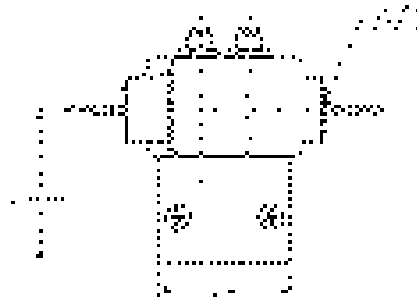
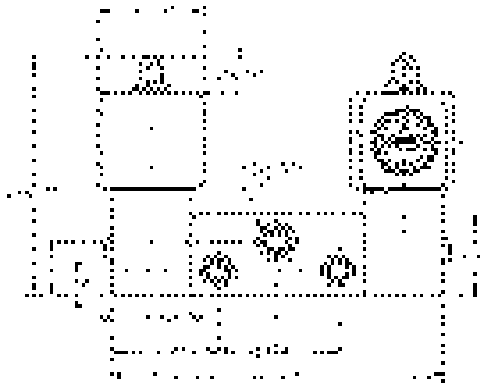
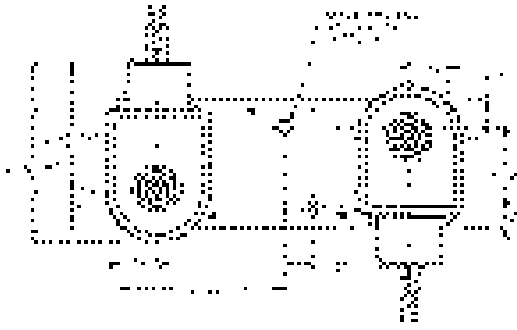

Construction Reference 14

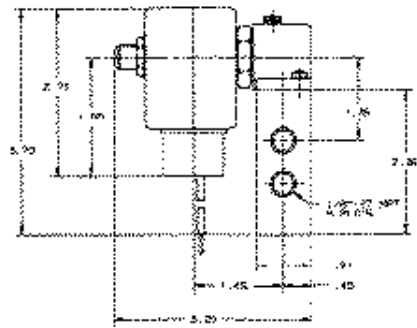
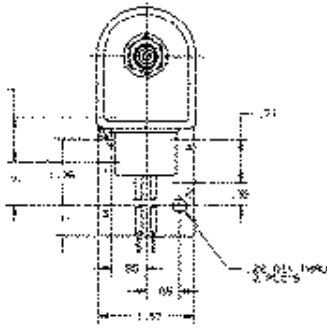

Construction Reference 15

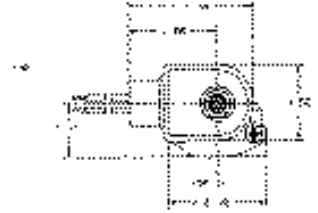
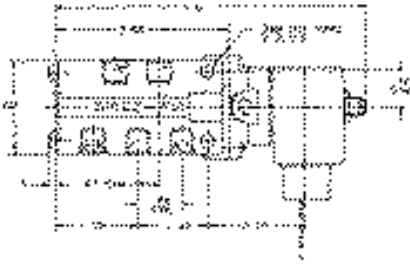

Construction Reference 16

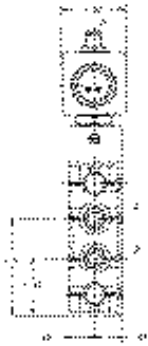

Construction Reference 17

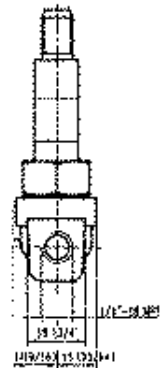
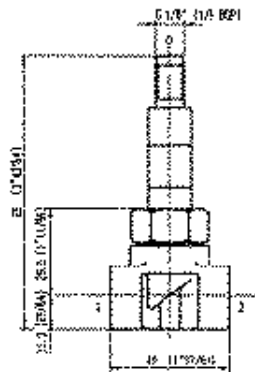
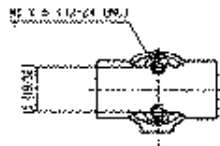

Construction Reference 18

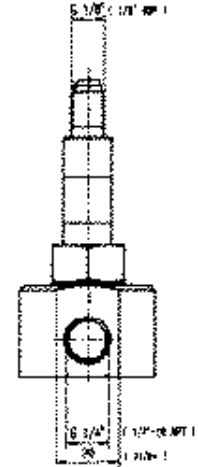
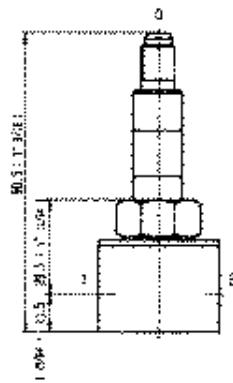
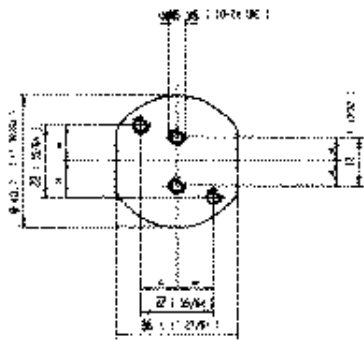

Construction Reference 19

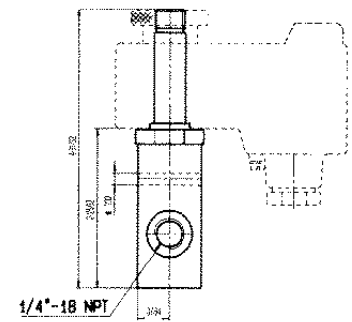
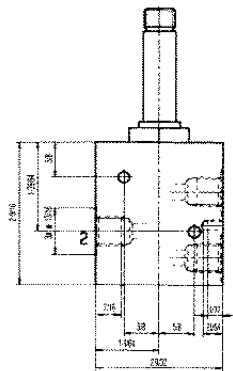
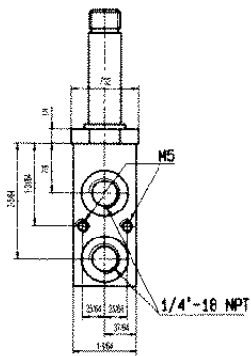

Construction Reference 20

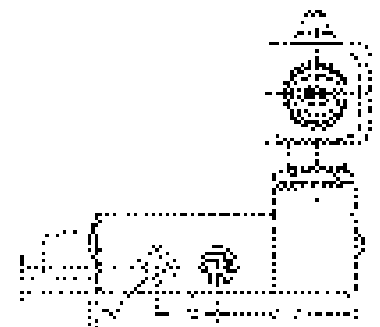
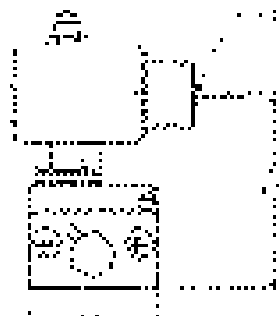
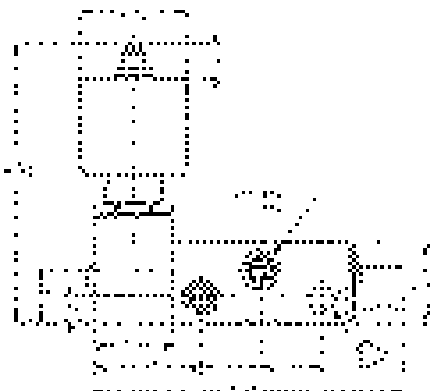
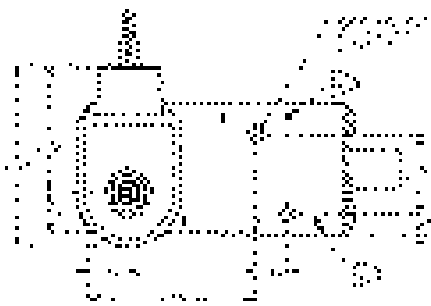

Construction Reference 21

▶ For 4-Way valve only.

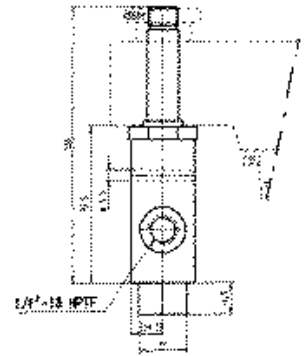
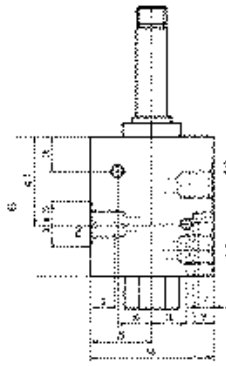
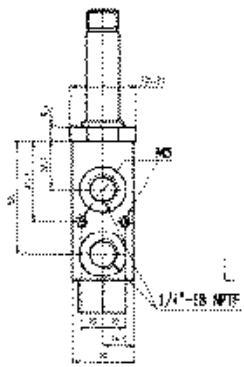

Construction Reference 22

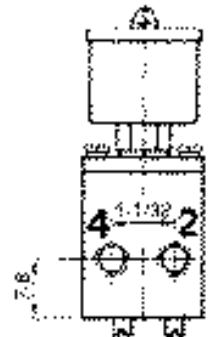
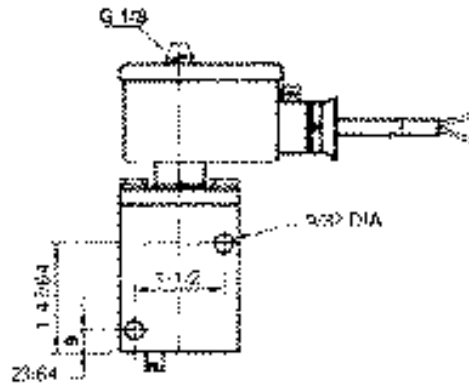
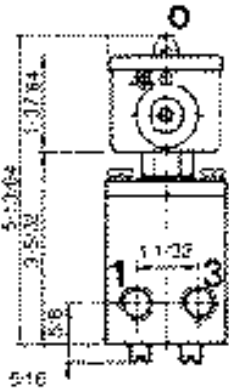
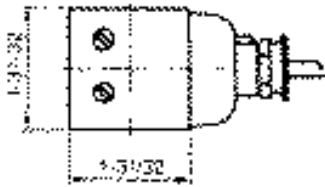

Construction Reference 23

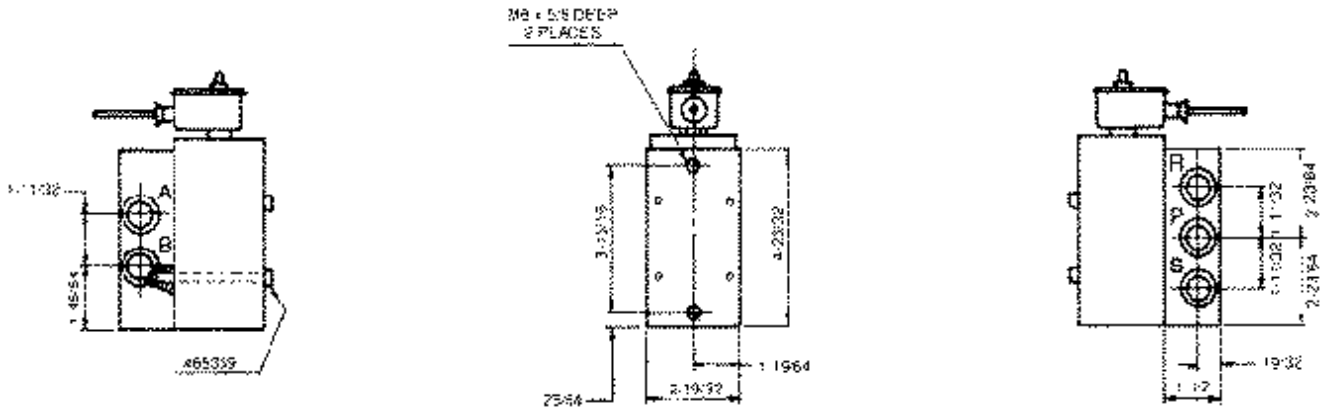

Construction Reference 24

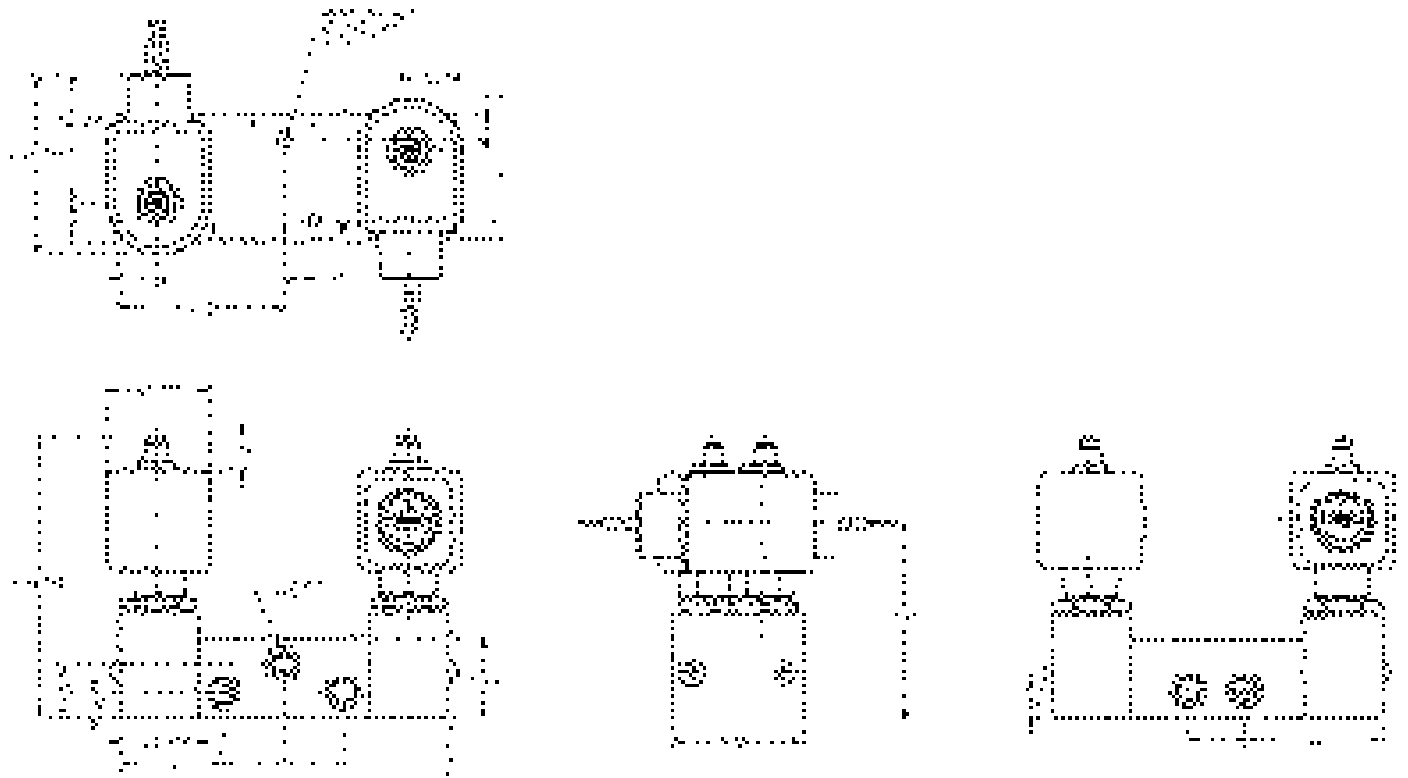

Construction Reference 25

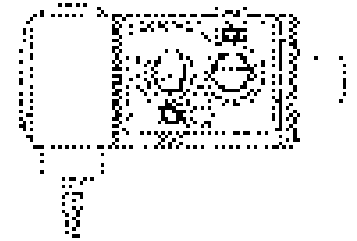
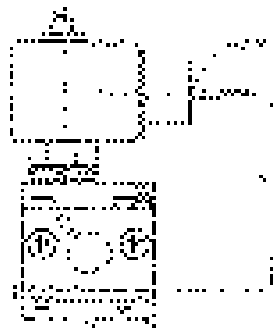
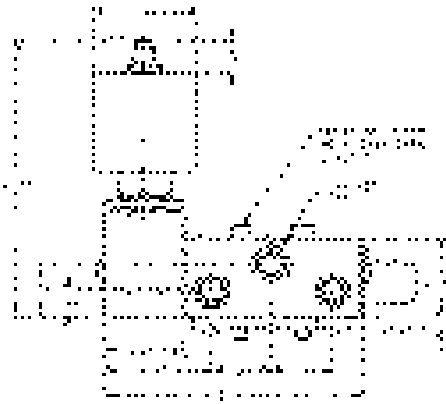
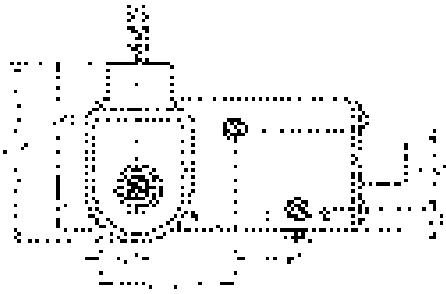

Construction Reference 26

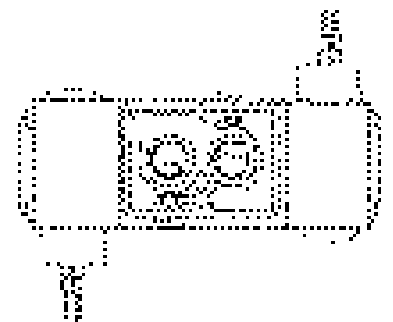
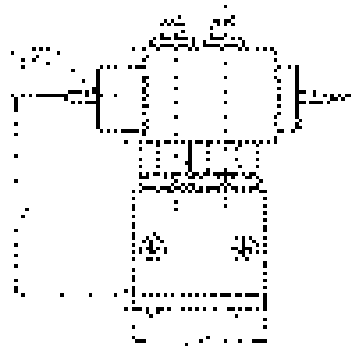
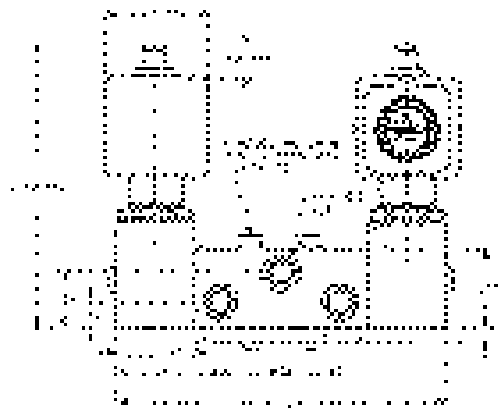
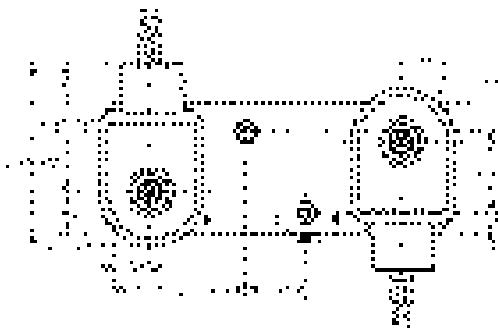

Construction Reference 27

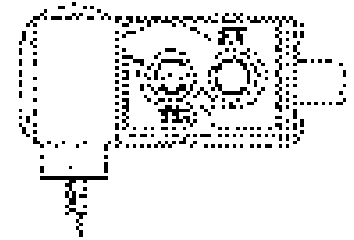
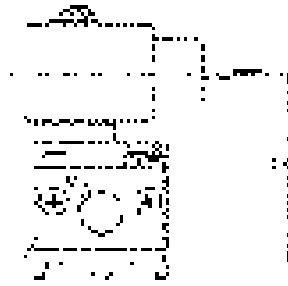
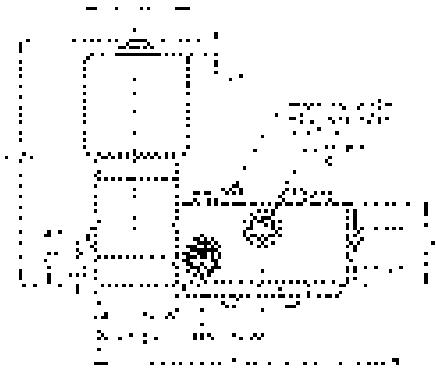
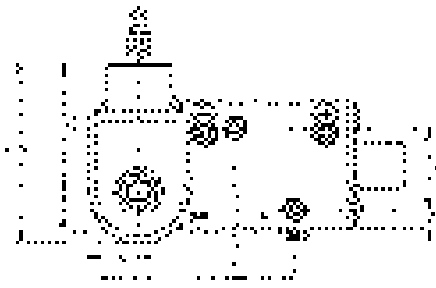

Construction Reference 30

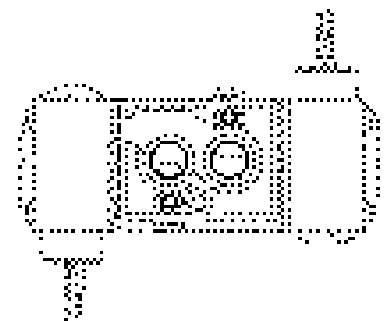
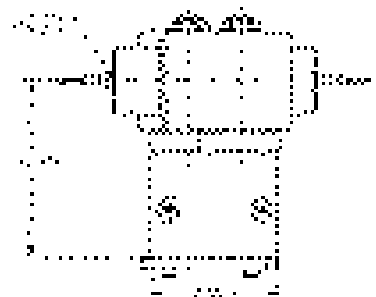
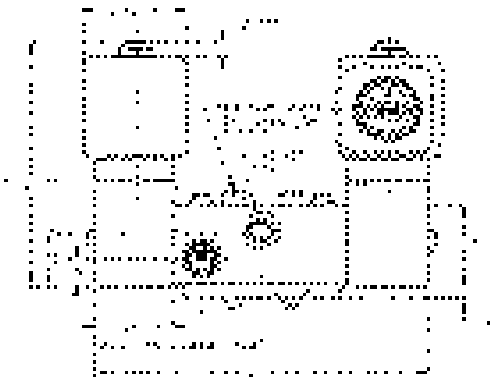
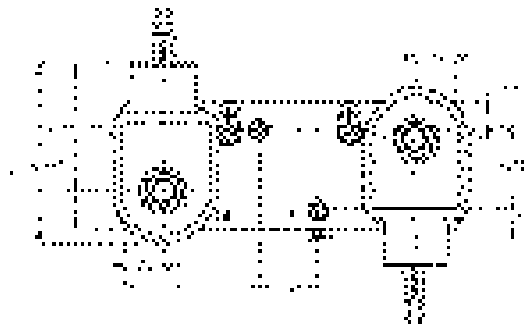

Construction Reference 31

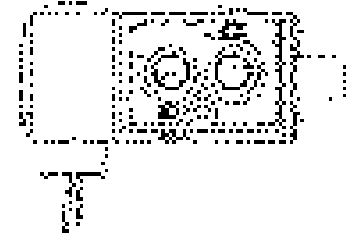
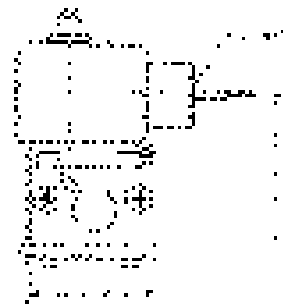
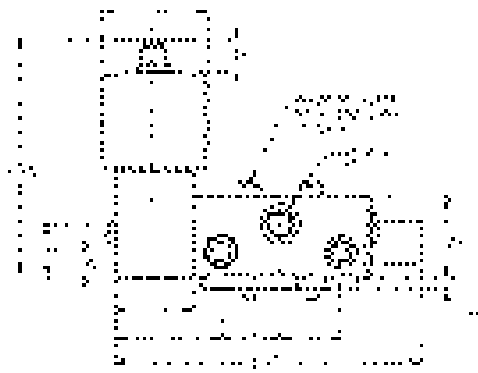
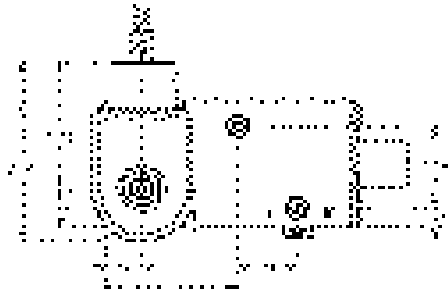

Construction Reference 32

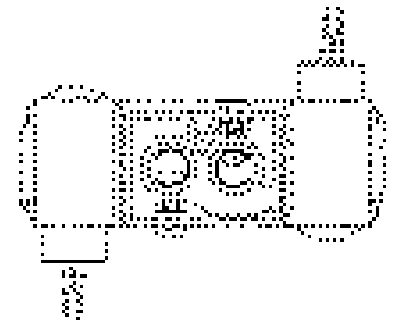
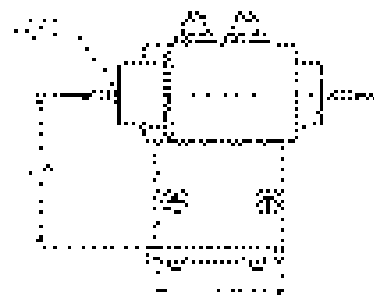
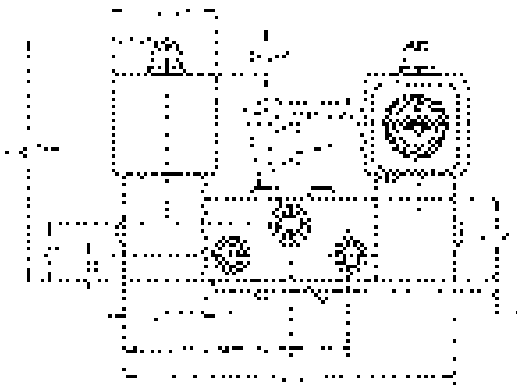
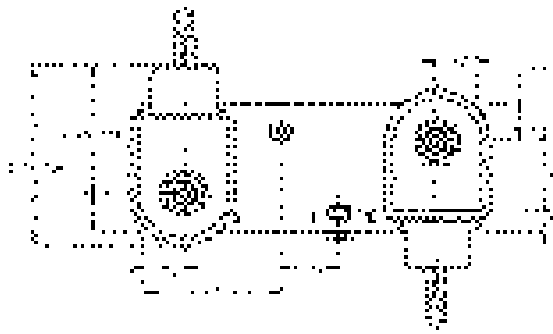

Construction Reference 33

Terms and Conditions of Sale

1. TERMS AND CONDITIONS OF SALE The order shall be subject to the terms and conditions set forth herein, notwithstanding any terms and conditions that may be contained in any order, acknowledgment or other form of Buyer. Such terms and conditions of Buyer shall not bind Seller unless accepted by it in writing, whether or not they manually alter this order. This order shall be governed in all respects by the law of the State of Ohio.

2. Stenographical and clerical errors are subject to correction. Until order is accepted, prices are subject to change without notice. All quotations, unless otherwise stated, are for immediate acceptance. All orders and contracts subject to approval if accepted by a salesman or selling agent. Prices do not include special taxes now in effect or later put in effect.

3. PAYMENT Payment shall not prejudice claims on account of omissions or shortages but no such claim will be allowed unless made within 30 days after receipt by Buyer.

4. Accounts are opened only with firms or individuals on approved credit. The Seller reserves the privilege of declining to make deliveries except for cash whenever, for any reason, doubt as to the Buyer's financial responsibility develops and shall not, in such event, be held liable for non-performance of contract in whole or in part.

5. Terms are Net 30 days. F.O.B. New Britain, Connecticut, where credit rating has been established. In all other cases C.O.D. or cash with order.

6. There is a minimum order of \$100.00 net for manufacturer's terms unless specific minimum quantities are noted on the quotation.

7. All Shipments are made F.O.B. point of shipment. After delivery to the carrier, the risk of loss shall be on the Buyer and any claims for loss or damage in transit must be filed by the Buyer.

8. DELIVERY Seller shall not be liable for any delays in or failure of delivery due to acts of God or public authority, labor disturbances, accidents, fires, floods, extreme weather conditions, failure of and delays by carriers, shortages of material, delays of a supplier or any other cause beyond Seller's control. Buyer's requested delivery date or schedule shall be approximate and subject to Seller's acceptance.

9. PREMIUM FREIGHT Shipments are made via common carrier. Any premium freight must be requested and paid for by the Buyer.

10. In making of materials to customer specifications, it is impossible to produce exactly the quantity ordered and it is, therefore, agreed all orders are subject to over or under shipment of 5% on orders over 500 pieces, 10% on orders less than 500 pieces.

11. WARRANTIES Seller warrants the goods sold hereunder to be free from defects in material and workmanship under normal use and service for a period of two (2) years from date of shipment from Skinner Valve's facility. THE ABOVE WARRANTIES COMPRISE SELLER'S SOLE AND ENTIRE WARRANTY OBLIGATIONS AND LIABILITY TO BUYER, ITS CUSTOMERS OR ASSIGNS IN CONNECTION WITH GOODS SOLD HEREUNDER SELLER EXTENDS NO WARRANTY TO THE ULTIMATE CONSUMERS OR USERS. ALL OTHER WARRANTIES, EXPRESS OR IMPLIED, INCLUDING BUT NOT LIMITED TO, WARRANTIES OF MERCHANTABILITY AND FITNESS, ARE EXPRESSLY EXCLUDED. Seller's sole obligation under these warranties shall be to repair or replace any item or part thereof which is proved to be other than as warranted. When claiming a breach of the above warranties, Buyer must notify Seller promptly whereupon Seller will either examine the goods at their site or issue shipping instructions for return to Seller (transportation cost prepaid by Buyer). The above warranties shall terminate unless Buyer in writing claims for breach thereof within 90 days from Seller's plant where damage is not directly due to a defect in material or workmanship, nor do they apply to goods altered or repaired except when performed under Seller's specific authority, nor to articles furnished by Buyer or acquired at Buyer's request and or to Buyer's specifications.

12. CONSEQUENTIAL DAMAGES In no event shall Seller be liable for consequential or special damages arising out of a delay in or failure of delivery, defects in material or workmanship, or arising out of breach by Seller of any other term or obligation of Seller under this contract.

13. CHANGES IN SPECIFICATIONS OR DESIGN If Buyer requests changes in specifications or designs related to any goods, delivery schedules shall be revised, if necessary, and an equitable adjustment, upward or downward, shall be made in price if warranted.

14. CANCELLATIONS AND RESCHEDULES Cancellations and reschedules are subject to acceptance by Seller, and are also subject to cancellation charges and price increases.

15. RETURNED GOODS No material shall be returned without our consent. When material is returned, with our consent, credit will be allowed only for that which is in good condition and can be resold. Freight must be prepaid on such shipments. The amount of freight paid by us on the original shipment to consignee is not subject to credit. Credit for approved returns is provided at a discount of 58% off list price at the time of purchase.

16. SPECIAL TOOLS Any special tools, jigs, patterns, etc. which Seller makes or acquires for Buyer, notwithstanding any change therefore, shall be and remain Seller's property subject to its possession and control: In no event shall Buyer have any tooling belonging to Seller which is utilized in the production of goods for Buyer, or which has been converted or adapted by Seller for such use, notwithstanding any charge for any such utilization, conversion or adaptation Seller shall have the right to alter discard or otherwise dispose of any tooling without liability to Buyer when for two (2) consecutive years no orders have been received from Buyer requiring the use of such tooling.

17. BUYER'S PROPERTY Any design, tools, patterns, drawings, information or equipment furnished by Buyer, or any special tools made or acquired for the Buyer by the Seller which becomes Buyer's property, shall be used only in the production of goods ordered by Buyer and not otherwise, unless by Buyer's written consent, provided that such property may be considered obsolete and destroyed by Seller when for two (2) consecutive years no orders are received from Buyer for products to be made with such property. Seller agrees to exercise reasonable care with respect to such property and equipment while in its possession and control, but shall not be responsible for loss or damage occurring without its fault or negligence or for ordinary wear and tear.

18. PATENT INDEMNITY Seller shall have no liability for patent infringement unless the goods furnished hereunder in and of themselves constitute the infringement. If they do, and Seller is notified of the claim of infringement within ten days after such claim is received by the Buyer and is permitted to settle or defend such claim. Seller will indemnify the Buyer against the reasonable expense of defending suit and against any judgment or settlement to which Seller agrees. However, such indemnity will be limited to an amount not exceeding the price paid by Buyer to Seller for infringing goods. If an injunction is issued against the further use of the goods, Seller will have the option of either procuring for the Buyer the right to use the goods, replacing them with non-infringing goods, modifying them so that they become non-infringing, or refunding the purchase price. The foregoing constitutes Seller's entire warranty and liability as to patents. If the goods furnished hereunder are in accordance with a design furnished by the Buyer, the Buyer will defend and save harmless Seller from all costs, expenses and judgments on account of any claim of infringement of any patent.

19. TAXES Any sales, use, excise or similar tax payable by Seller which is or may be imposed by any taxing authority upon the manufacture, sale or delivery of goods covered by this order, or any increase in rate of any such tax now in force, shall be added to the sales price, if not collected at the time of payment of sales price, Buyer will hold Seller harmless.

20. ADDITIONAL CONDITIONS APPLICABLE TO ORDERS PLACED UNDER GOVERNMENT CONTRACTS OR SUBCONTRACTS THEREUNDER If Buyer notifies Seller that goods ordered hereunder are for use under a prime contract with an agency of the United States Government, the following terms and conditions of the Armed Services Procurement Regulations shall be incorporated into Seller's terms of sale insofar as Buyer may be required to incorporate such provision in its subcontracts or insofar as applicable to the goods hereunder. WALSH-HEALEY PUBLIC CONTRACTS ACT (12-605), RENEGOTIATION (7-103-13), BUY AMERICAN ACT (6-104,5), EXAMINATION OF RECORDS (7-104 15), AUDIT AND RECORDS (7-104,41), PRICE REDUCTION FOR DEFECTIVE COST OR PRICING DATA (7-104,29), CONVICT LABOR (12-203), NOTICE OF THE GOVERNMENT OF LABOR DISPUTES (7-104,4), WORK HOURS ACT (12-303,1), EXCESS PROFITS (7-104,11) MILITARY SECURITY REQUIREMENT (7-104,12), TERMINATION (8-706), EQUAL OPPORTUNITY (12-802).

21. PRICES SHOWN HEREON ARE STATED AT CURRENT RAW MATERIAL COSTS AND ARE SUBJECT TO CHANGE AS FLUCTUATIONS IN THE MARKET SO DICTATES.

22. OTHER SERVICES The prices issued in this schedule are for standard packaged products only. Any additional or supplemental services, material, or product marking or identification are subject to additional charges at the discretion of Parker.

23. Where the Buyer requires tests for inspection not regularly provided, Parker reserves the right to charge an additional reasonable amount.

24. COMPLIANCE WITH LAW Seller warrants that products sold or services furnished will be produced or furnished in full and complete compliance with all applicable federal, state, or local statutes, rules, regulations and orders, including those pertaining to labor, hours and conditions of employment, and in particular the Fair Labor Standards Act, as amended, and Executive Order No. 11248 (Equal Employment Opportunity) effective October 24, 1965, with all amendments thereto or as it may be superseded. Seller agrees that all the provisions of said Executive Order, as it may be amended or superseded, are hereby made a part hereof by reference and are binding upon Seller. Seller further agrees and confirms that Seller as a subcontractor or vendor has complied with and will comply with the provisions of said Executive Order and the rules and regulations promulgated under the authority thereof, including among others, reporting requirements.



UNITED STATES

Skinner Valve Division
 Parker Hannifin Corporation
 Climate & Industrial Controls Group
 95 Edgewood Ave.
 New Britain, CT 06051-9914 USA
 Tel: (860) 827-2300
 Fax: (860) 827-2384
 email: skinner@parker.com

LATIN AMERICA and CARIBBEAN

Honeywell Inc.
 480 Sawgrass Corporate Parkway
 Suite 200
 Sunrise, FL 33325, USA
 Tel: (954) 845-2600
 Fax: (954) 845-2605

Singapore

Parker Hannifin Singapore Pte Ltd.
 No. 11 4th Chin Bee Road
 Jurong Town, Singapore 619702
 Republic of Singapore
 Tel: (65) 261-5233
 Fax: (65) 265-5125, 261-4929

ASIA PACIFIC

Australia
Parker Hannifin (Australia) Pty. Ltd
 9 Carrington Road
 Castle Hill NSW 2154, Australia
 Tel: (61) 2 9 634 7777
 Fax: (61) 2 9 842 5111

Taiwan

Parker Hannifin Taiwan Co., Ltd.
 8F-1, No. 102 Sung Lung Rd.
 Taipei, Taiwan, ROC
 Tel: 886 2 8787 3780
 Fax: 886 2 8787 3782

EUROPE, MIDDLE EAST and AFRICA

Parker Lucifer SA
 P.O. Box 1456
 CH-1227 Carouge/Geneva, Switzerland
 Tel: 41 22 3077 111
 Fax: 41 22 3077 110

New Zealand

Parker Hannifin (N.Z.) Limited
 103 Harris Road, East Tamaki
 Private Bag 94420, Greenmount
 Auckland, New Zealand
 Tel: (64 9) 273 8944
 Fax: (64 9) 273 8943

CHINA REGION

Parker Hannifin Hong Kong Ltd.
 Unit A, 10th Floor
 Chung Shun Knitting Center
 1-3 Wing Yip St
 Kwai Chung NT
 Hong Kong
 Tel: (852) 2428-8008
 Fax: (852) 2480-4256

Republic of South Africa

Parker Hannifin (Africa) (Pty) Ltd.
 Parker Place
 10 Berne Avenue
 Aeroport, Kempton Park
 P.O. Box 1153
 Kempton Park 1620
 Republic of South Africa
 Tel: (27) (11) 392-7280
 Fax: (27) (11) 392-7213

India

Honeywell India 2152
 403/404 "Madhava"
 Bandra Kurla Complex
 Bandra (East)
 Bombay 400 051, India
 Tel: 91-22 643 3275
 Fax: 91-22 640 9513

Parker Hannifin Beijing Office

Suite 01B, 5th Floor, CITIC Building 19
 Jianguomenwai Avenue
 Beijing 100004, China
 Tel: 8610 6500 7888
 Fax: 86 10 6500 6339

CANADA

Parker Hannifin (Canada) Inc.
 Skinner Valve Division
 530 Kipling Avenue
 Toronto, Canada
 M8Z 5E6
 Tel: 416 255-1585
 1-888-249-4806
 Fax: 416-255-2107

Japan

Yamatake-Corporation
 1-12-2, Kawana, Fujisawa
 Kanagawa, 251
 Tel: (81) 466 20 2232
 Fax: (81) 466 20 2193

Parker Hannifin Shanghai Office

Rm 703, Dynasty Business Center
 No. 457 North Wu Lu Mu Qi Road
 Shanghai 200040, China
 Tel: 86 21 62490308
 Fax: 86 21 62494657

MEXICO

Honeywell S. A. de C. V.
 Av. Constituyentes No 900
 Col. Lomas Altas
 11950 Mexico, D.F., Mexico
 Tel: (52-5) 259-1966
 Fax: (52-5) 570-2402

Korea

LG-Honeywell Co Ltd
 17F, Hanil Group Building
 191 Hangangro-2 ga, Yongsan-gu
 Seoul 140-702, Korea
 Tel: (822) 799 6011
 Fax: (822) 792 9013