

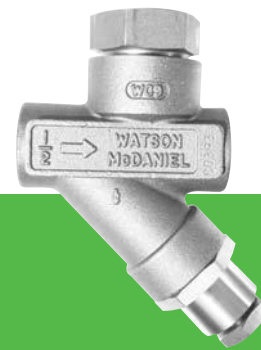

Watson McDaniel

**Manufacturing
High-Quality
Steam & Fluid
Specialty Products
for Industry**

*Made in the USA
Since 1878*

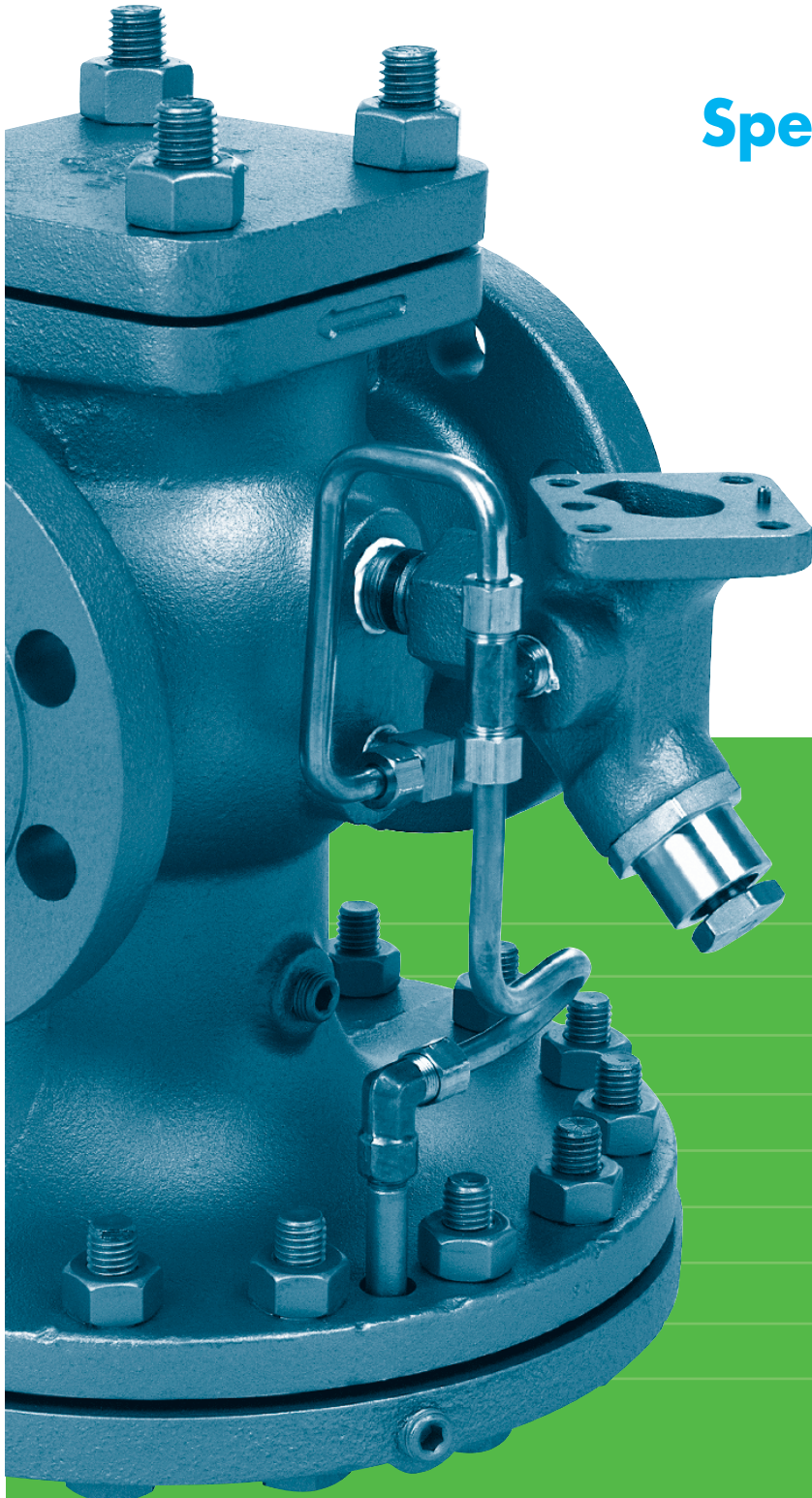

- Steam Traps
- Pressure Regulators
- Temperature Regulators
- Control Valves
- Condensate Pumps
- Relief Valves
- Liquid Drainers
- Check Valves
- Other Specialty Products

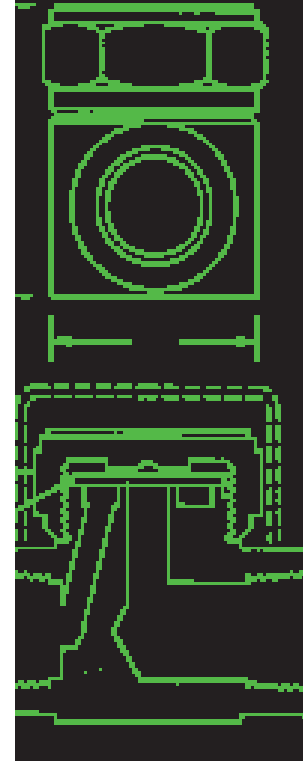

Product Catalog

Steam Traps
Pressure Regulators
Temperature Regulators
Control Valves
Condensate Pumps
Relief Valves
Liquid Drainers
Check Valves
Other Specialty Products



Manufacturing High-Quality Steam & Fluid Products for Industry

For over 100 years, **Watson McDaniel** has been manufacturing a wide range of steam specialty and fluid products for the industrial marketplace. These time-tested products have made the operation of steam, compressed air, heat transfer and fluid systems substantially more effective and efficient.

In 1995, **Watson McDaniel** received its **ISO 9001** Quality Certification as industry recognition of our continued commitment to world class manufacturing, assembly and quality control procedures. This level of quality certification assures our customers unequaled dependability of our products. Our manufacturing facilities, with over fifty computer numerical controlled (CNC) machining centers, is considered the most modern in the industry. This gives us both the capacity and capability to rapidly respond to our customers' needs.



Watson McDaniel serves the global marketplace with a network of Manufacturers, Representatives, Distributors, Manufacturing Plants and Sales Offices located throughout the world. In 1997, a Manufacturing Plant and Sales Office was opened in Shanghai, China to fulfill the growing demands of steam specialty products in the Far East. The success of this operation has allowed us to quickly deliver products with competitive prices to our customers throughout this region.

The structure of our operation affords us the ability to give highly personalized attention to each and every customer. Most importantly, this structure gives us the ability to respond immediately to our customers' requests as well as providing highly cost-effective products within the global marketplace. We are confident that you will want to consider our products when choosing a solution for your steam system and fluid applications.



428 Jones Boulevard
Limerick Airport Business Center
Pottstown PA • 19464
Tel. 610.495.5131
Fax. 610.495.5134

www.watsonmcdaniel.com



Member of
FCI
Fluid Controls Institute, Inc.

Table of Contents



Steam Traps

Page 2-72

- Thermodynamic • Thermostatic • Float & Thermostatic • Inverted Bucket
- Universal Style Steam Traps (Universal Connectors & Modules)
- Clean Steam • Bi-Metallic • Manifolds

STEAM TRAPS



Condensate Return Pumps

Page 73-115

- Non-Electric Condensate Return Pumps – PMP Series
- Standard & Customized Skid Mounted Systems • Receiver Tanks
- Pump-Trap Combinations • Accessories & Options • Insulation Jackets
- Gauge Glass • Cycle Counters • Electric Condensate Pumps

PUMPS



Pilot-Operated Regulating Valves

Page 116-151

- Back Pressure • Temperature • Pressure & Temperature
- Solenoid On/Off • Differential Pressure • Air-Operated
- Pneumatic Temperature Controller • Noise Attenuators

PILOT-OPERATED REGULATING VALVES



Direct-Operated Pressure & Temperature Regulating Valves

Page 152-183

- Pressure • Back Pressure & Relief Valves • Temperature

DIRECT-OPERATED REGULATING VALVES



Control Valves

Page 184-205

- Pneumatic Control Valves • Electropneumatic (I/P) Transducer
- Control Loops • Electronic PID Controllers • Air Filter/Regulator
- RTD & Thermocouple Temperature Sensors • Thermowells

CONTROL VALVES



Liquid Drainers

Page 206-223

- Float Type • Inverted Bucket • Thermodynamic
- Guided Float Type • Installation Guidelines

LIQUID DRAINERS



Specialty Products

Page 224-260

- Steam Humidifiers • Safety Relief Valves • Strainers • Mixing Tees • Ejectors
- Air Eliminators • Air Vents • Separators • Exhaust Heads • Vacuum Breakers
- Check Valves • Freeze Protection • Scald Protection • Drip Pan Elbows
- Flash Tanks • Steam Trap Test Valves

SPECIALTY PRODUCTS

Engineering Data

Page 261-321

- Formulas, Conversions & Guidelines • Steam Properties & Flow Characteristics
- Fluid Flow in Piping • Pipe, Fitting & Flange Specifications
- Steam Trap Applications • Regulating Valve Applications
- Pressure Motive Pump (PMP) Applications

ENGINEERING

PRODUCT CROSS REFERENCE

322-329

To download any portion of this catalog go to:
www.watsonmcdaniel.com



Steam Traps



WD600



WD600S



WD700S



WD900S

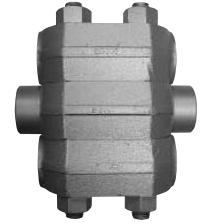

WD3600

THERMODYNAMIC

6-15

Model	Body Material	PMO (PSIG)	Sizes	Connections	Page No.
WD600	Stainless Steel	600	3/8" – 1"	NPT	6-7
WD600S	Stainless Steel	600	1/2", 3/4", 1"	NPT	8-9
WD700S	Alloy Steel	600	1/2", 3/4", 1"	NPT, SW, FLG	10-11
WD900S	Alloy Steel	900	1/2", 3/4", 1"	NPT, SW, FLG	12-13
WD3600	Alloy Steel	3600	1/2", 3/4", 1"	BW, SW, FLG	14-15



WT1000



WT2500



WT2000C



WT3000



WT4000



WT5000



TT25B/TT125

THERMOSTATIC

16-27

Model	Body Material	PMO (PSIG)	Sizes	Connections	Page No.
WT1000	Stainless Steel	300	1/2", 3/4"	NPT	16
WT2500	Cast Iron	250	1/2", 3/4"	NPT	17
WT2000C	Stainless	650	1/2", 3/4"	NPT	18-19
WT3000	Stainless Steel	650	1/2", 3/4"	NPT, SW, FLG	20-21
WT4000	Stainless Steel	300	3/4", 1"	NPT, SW, FLG	22-23
WT5000	Stainless Steel	650	3/8" – 1"	NPT, SW	24-25
TT25B/TT125	Brass	25/125	1/2", 3/4"	NPT	26-27

Steam Traps



FT



FT600 & FT601



FTE & FTES



FTT



WFT

FLOAT & THERMOSTATIC					28-40
Model	Body Material	PMO (PSIG)	Sizes	Connections	Page No.
FT	Cast Iron	75	3/4" – 2"	NPT	28-29
FT600/FT601	Carbon Steel/Stainless Steel	450	3/4" – 4"	NPT, SW, FLG	30-33
FTE/FTES	Ductile Iron/Cast Steel	200/300	1 1/2", 2", 2 1/2"	NPT, SW, FLG	34-35
FTT	Ductile Iron	300	1/2" – 2"	NPT	36-37
WFT	Cast Iron	250	3/4" – 2"	NPT	38-40



WSIB/WSIBH



1031



1032



1034



1041



1042



1044

INVERTED BUCKET					41-45
Model	Body Material	PMO (PSIG)	Sizes	Connections	Page No.
WSIB/WSIBH	Stainless Steel	450	1/2", 3/4"	NPT, SW	41
IB Series 103X/104X	Cast Iron	250	1/2" – 1 1/2"	NPT	42-45

PMO = Maximum Operating Pressure

Steam Traps

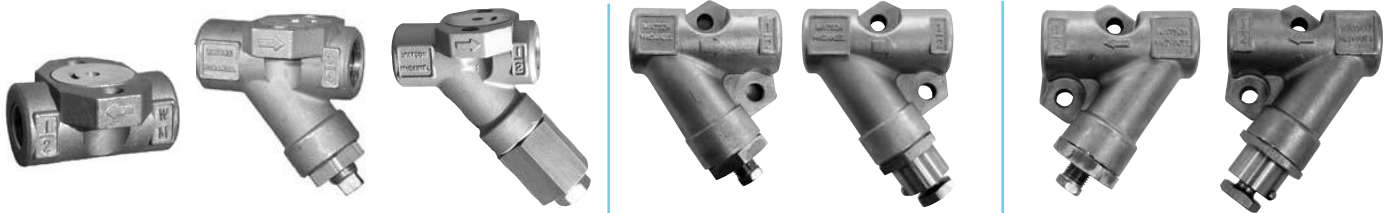

WU450 WU450S WU450SB WU450S-LR WU450SB-LR WU450S-RL WU450SB-RL

WU450 Series UNIVERSAL CONNECTORS 46-51

Model	Type	Body Material	PMO (PSIG)	Sizes	Connections	Page No.
WU450 Series	Universal Connectors	Stainless Steel	Trap Module Dependent	1/2", 3/4", 1"	NPT, SW, FLG	46-51



WSIB450/WSIB450H WFT450 WD450 WD450SM WT450 WB450

450 Series UNIVERSAL STEAM TRAP MODULES 52-57

Model	Type	Body Material	PMO (PSIG)	Sizes	Connections	Page No.
WSIB450/WSIB450H	Inverted Bucket	Stainless Steel	450	Use WU450SM connector	Universal Conn.	52
WFT450	Float & Thermostatic	Stainless Steel	225	Use WU450 & WU450SM connectors	Universal Conn.	53
WD450/WD450SM	Thermodynamic	Stainless Steel	450	Use WU450 connector	Universal Conn.	54
WD600LSM-HP	High Pressure Thermodynamic	Stainless Steel	600	Use WU450SM connector	Universal Conn.	55
WT450	Thermostatic	Stainless Steel	450	Use WU450 connector	Universal Conn.	56
WB450	Bi-Metallic	Stainless Steel	450	Use WU450 connector	Universal Conn.	57

450 Series UNIVERSAL STYLE STEAM TRAPS (Trap Module with Connectors) 58-61

Steam Traps



FDA400



FDA500



FDA600



FDA800

CLEAN STEAM

62-65

Model	Body Material	PMO (PSIG)	Sizes	Connections	Page No.
FDA400	Stainless Steel	90	1/2", 3/4"	Tri-Clamp	62
FDA500	Stainless Steel	90	1/2", 3/4", 1"	Tri-Clamp, NPT, TW	63
FDA600	Stainless Steel	110	1/2", 3/4", 1"	Tri-Clamp, NPT, TW	64
FDA800	Stainless Steel	150	1/2"	Tri-Clamp, NPT, TW	65



WPN

BI-METALLIC

66-69

Model	Body Material	PMO (PSIG)	Sizes	Connections	Page No.
WPN	Alloy Steel or Carbon Steel Variation	470-2700	1/2" - 2"	NPT, FLG, SW, BW	66-69



FM



FSM

MANIFOLDS

70-72

Model	Body Material	PMO (PSIG)	Sizes	Connections	Page No.
FM/FSM	Carbon Steel/Forged Steel	720/600	1/2", 3/4"	NPT, SW	70-72

PMO = Maximum Operating Pressure

STEAM TRAPS

WD600

Thermodynamic Steam Trap

Watson McDaniel reserves the right to change the designs and/or materials of its products without notice.
©2010 Watson McDaniel Company

Model	WD600, WD600L
Sizes	3/8", 1/2", 3/4", 1"
Connections	NPT
Body Material	Stainless Steel 420F
Options	Insulation Cap
PMO Max. Operating Pressure	600 PSIG
TMO Max. Operating Temperature	800°F
PMA Max. Allowable Pressure	600 PSIG up to 800°F
TMA Max. Allowable Temperature	800°F @ 600 PSIG

**TYPICAL APPLICATIONS**

DRIP, TRACER: The **WD600** thermodynamic steam trap is commonly used as a drip trap on steam mains and steam supply lines. These traps can be used on tracing applications; however, thermostatic traps are normally recommended for this service. Ideal for outdoor applications that are subject to freezing and for superheated steam conditions.

HOW IT WORKS

The thermodynamic trap has cyclic on-off operation with a disc that is pushed open by incoming condensate and closes tightly when steam tries to escape.

FEATURES

- High pressure applications up to 600 PSIG
- Hardened stainless steel seat and disc for extended service life even at high pressure
- Single trap will operate over the entire pressure range of 3.5-600 PSIG (Not recommended for use below 10 PSI)
- Suitable for superheated steam
- Freezeproof when trap is piped in a vertical orientation for complete drainage of condensate
- Three-hole balanced discharge extends life of the seat area
- Trap will function in any orientation (horizontal preferred)

SAMPLE SPECIFICATION

The steam trap shall be a thermodynamic disc type with all stainless steel construction. Integral seat design and disc to be hardened for long service life. Unit shall be capable of installation in any orientation and self-draining when mounted vertically.

INSTALLATION

Trap can be installed in any position; however, horizontal is preferred. Installation should include isolation valves and a 20 mesh strainer. Do not weld as damage can occur to the seat area.

MAINTENANCE

Dirt is the most common cause of premature failure. For full maintenance details, see Installation and Maintenance Manual.

OPTIONS

An insulation cap is available to reduce cycle rates and steam loss in rain, snow, or cold environments.

WD600L

WD600L is a low capacity version of the standard WD600 model.

1/2" WD600L has the same capacity as the **3/8" WD600**.

3/4" WD600L has the same capacity as the **1/2" WD600**.

WD600

Thermodynamic Steam Trap

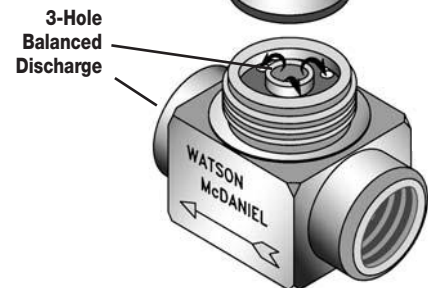
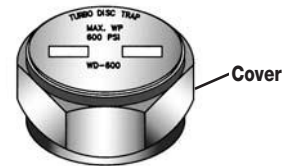
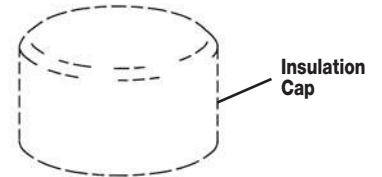
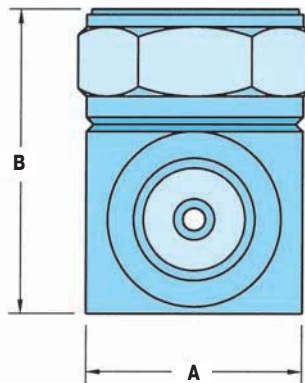
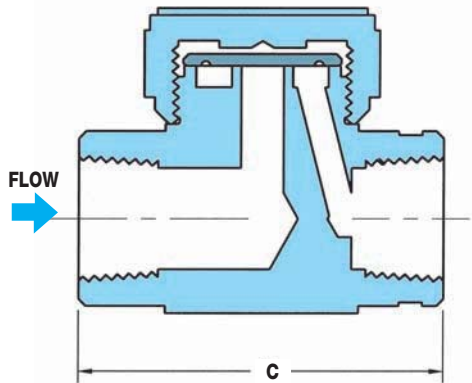

DIMENSIONS & WEIGHTS – inches/pounds

Size/Model	Connection	A	B	C	Weight (lbs)
3/8" WD600	NPT	1.375	1.6875	2	0.75
1/2" WD600	NPT	1.5	2	2.6875	1.25
3/4" WD600	NPT	1.75	2.375	2.8125	2.0
1" WD600	NPT	2.125	2.8125	3.8175	3.0
1/2" WD600L	NPT	1.5	1.8125	2.718	1.0
3/4" WD600L	NPT	1.5	2.25	2.75	1.75

HOW TO SIZE/ORDER

Select working pressure; follow column down to correct capacity (lbs/hr) block. Example:

Application: 650 lbs/hr at 30 PSIG working inlet pressure

Size/Model: 3/4" **WD600**

MATERIALS

Body	Stainless Steel, AISI 420F
Disc	Stainless Steel, AISI 420
Cover	Stainless Steel, AISI 416
Insulation Cap	Stainless Steel, AISI 304

CAPACITIES – Condensate (lbs/hr)

Size/Model	Steam Inlet Pressure (PSIG)																				
	3.5	5	10	15	20	25	30	40	50	75	100	150	200	250	300	350	400	450	500	550	600
3/8" WD600 1/2" WD600L	180	185	190	195	200	215	220	230	250	310	375	500	620	710	800	825	900	1070	1120	1185	1290
1/2" WD600 3/4" WD600L	300	315	350	380	415	440	470	515	580	710	825	1020	1165	1300	1440	1565	1670	1775	1880	1960	2060
3/4" WD600	415	430	475	520	565	610	650	720	825	1020	1185	1480	1710	1950	2110	2265	2490	2625	2780	2985	3140
1" WD600	650	680	740	815	885	940	1000	1080	1225	1500	1800	2215	2625	2935	3300	3600	3875	4120	4350	4560	4840

Notes: 1) Maximum back pressure not to exceed 80% of inlet pressure (measured in absolute pressure) or trap may not close.
2) For optimum performance, recommended for operating pressure above 10 PSIG.

STEAM TRAPS

WD600S

Thermodynamic Steam Trap

Watson McDaniel reserves the right to change the designs and/or materials of its products without notice.
©2010 Watson McDaniel Company

Model	WD600S, WD600LS
Sizes	1/2", 3/4", 1"
Connections	NPT
Body Material	Stainless Steel 420F
Options	Blowdown Valve, Insulation Cap
PMO Max. Operating Pressure	600 PSIG
TMO Max. Operating Temperature	750°F
PMA Max. Allowable Pressure	915 PSIG up to 250°F
TMA Max. Allowable Temperature	610°F @ 750 PSIG



**WD600S
Strainer**



**WD600SB
Strainer & Blowdown Valve**

TYPICAL APPLICATIONS

DRIP, TRACER: The **WD600S** thermodynamic steam trap is commonly used as a drip trap on steam mains and steam supply lines. Supplied with integral strainer and optional blowdown valve to protect the trap from contamination. These traps can be used on tracing applications; however, thermostatic traps are normally recommended for this service. Ideal for outdoor applications that are subject to freezing and for superheated steam conditions.

HOW IT WORKS

The thermodynamic trap has cyclic on-off operation with a disc that is pushed open by incoming condensate and closes tightly when steam tries to escape.

FEATURES

- Integral strainer with optional blowdown valve to protect trap from contamination
- High pressure applications up to 600 PSIG
- Hardened stainless steel seat and disc for extended service life even at high pressure
- Single trap will operate over the entire pressure range of 3.5-600 PSIG (Not recommended for use below 10 PSI)
- Suitable for superheated steam
- Freezeproof when trap is piped in a vertical orientation for complete drainage of condensate
- Three-hole balanced discharge extends life of the seat area
- Trap will function in any orientation (horizontal preferred)

SAMPLE SPECIFICATION

The steam trap shall be all stainless steel thermodynamic type with hardened integral seat and disc with integral strainer and blowdown valve.

INSTALLATION

Trap can be installed in any position; however, horizontal is preferred. Installation should include isolation valves. Do not weld or damage can occur to the seat area.

MAINTENANCE

If trap fails, close isolation valves and remove cap. Clean disc and seating surfaces and replace cap and disc with groove side toward seat. NOTE: Do not over tighten cap. For full maintenance details see Installation and Maintenance Manual.

OPTIONS

An insulation cap is available to reduce cycle rates and steam loss in rain, snow, or cold environments. Blowdown valve, used for flushing dirt and scale from strainer.

SB = Strainer and Blowdown Valve

L = Low Capacity

WD600LS

WD600LS is a low capacity version of the standard **WD600S** model. **3/4" WD600LS** has the same capacity as the **1/2" WD600S**.

WD600S

Thermodynamic Steam Trap

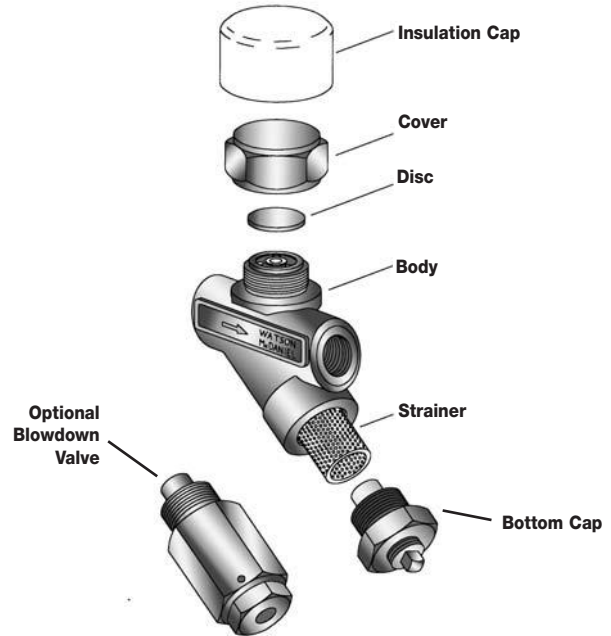
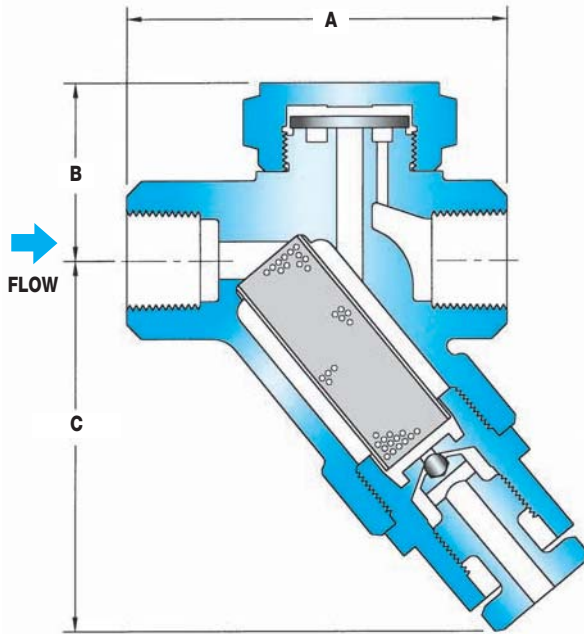

DIMENSIONS & WEIGHTS – inches/pounds

Size/Model	Connection	A	B	C	Weight (lbs)
Series WD600S (Strainer)					
1/2" WD600S	NPT	3.156	1.5	2.531	2
1/2" WD600LS	NPT	3.156	1.4375	2.531	1.5
3/4" WD600S	NPT	3.5625	1.625	2.531	2.5
3/4" WD600LS	NPT	3.5625	1.5625	2.531	2.4
1" WD600LS	NPT	3.75	1.4375	2.531	2.5
Series WD600SB (Strainer & Blowdown Valve)					
1/2" WD600SB	NPT	3.156	1.5	3.5	2.3
1/2" WD600LSB	NPT	3.156	1.4375	3.5	2.0
3/4" WD600SB	NPT	3.5625	1.625	3.5	2.8
3/4" WD600LSB	NPT	3.5625	1.5625	3.5	2.7
1" WD600LSB	NPT	3.725	1.4375	3.5	2.7

MATERIALS

Body	Stainless Steel, AISI 420F
Disc	Stainless Steel, AISI 420
Cover	Stainless Steel, AISI 416
Insulation Cap	Stainless Steel, AISI 304
Strainer Screen	Stainless Steel, AISI 304
Blowdown Valve	Stainless Steel, AISI 303

HOW TO SIZE/ORDER

Select working pressure; follow column down to correct capacity (lbs/hr) block. Example:

Application: 650 lbs/hr at 30 PSIG working inlet pressure
 Size/Model: 3/4" **WD600S**

CAPACITIES – Condensate (lbs/hr)

Size/Model	Steam Inlet Pressure (PSIG)																				
	3.5	5	10	15	20	25	30	40	50	75	100	150	200	250	300	350	400	450	500	550	600
1/2" WD600LS	180	185	190	195	200	215	220	230	250	310	375	500	620	710	800	825	900	1070	1120	1185	1290
1" WD600LS	180	185	190	195	200	215	220	230	250	310	375	500	620	710	800	825	900	1070	1120	1185	1290
1/2" WD600S	300	315	350	380	415	440	470	515	580	710	825	1020	1165	1300	1440	1565	1670	1775	1880	1960	2060
3/4" WD600LS	300	315	350	380	415	440	470	515	580	710	825	1020	1165	1300	1440	1565	1670	1775	1880	1960	2060
3/4" WD600S	415	430	475	520	565	610	650	720	825	1020	1185	1480	1710	1950	2110	2265	2490	2625	2780	2985	3140

Note: Maximum back pressure not to exceed 80% of inlet pressure (measured in absolute pressure) or trap may not close.

Note: For optimum performance, recommended for operating pressure above 10 PSIG.

STEAM TRAPS

WD700S

Thermodynamic Steam Trap (Repairable)

Watson McDaniel reserves the right to change the designs and/or materials of its products without notice.
©2010 Watson McDaniel Company

Model	WD700S, WD700HS
Sizes	1/2", 3/4", 1"
Connections	NPT, SW, FLG
Body Material	Chrome-Moly Alloy Steel
Options	Blowdown Valve, Insulation Cap
PMO Max. Operating Pressure	600 PSIG
TMO Max. Operating Temperature	800°F
PMA Max. Allowable Pressure	600 PSIG up to 800°F
TMA Max. Allowable Temperature	800°F @ 600 PSIG

WD700S is a Direct Replacement for Yarway Model 721



**WD700S
Strainer**



**WD700SB
Strainer &
Blowdown Valve**

TYPICAL APPLICATIONS

DRIP, TRACER: The **WD700S** thermodynamic steam trap is commonly used as a drip trap on steam mains and steam supply lines. These traps are used on tracing applications; however, thermostatic traps are normally recommended for this service. Supplied with an integral strainer and optional blowdown valve to protect the trap from contamination. The internal working mechanism of the WD700S can be completely replaced while the trap body remains in line. Ideal for outdoor applications that are subject to freezing and for superheated steam conditions.

HOW IT WORKS

The thermodynamic trap has cyclic on-off operation with a disc that is pushed open by incoming condensate and closes tightly when steam tries to escape.

FEATURES

- "Quick Change" capsule design for easy in-line repair
- Integral strainer with optional blowdown valve to protect trap from contamination
- High pressure applications up to 600 PSIG
- Hardened stainless steel seat and disc for extended service life even at high pressure
- Single trap will operate over the entire pressure range 4-600 PSIG (Not recommended for use below 10 PSI)
- Suitable for superheated steam
- Freezeproof when trap is piped in a vertical orientation for complete drainage of condensate
- Weldable body in chrome-moly alloy steel
- Trap will function in any orientation (horizontal preferred)

SAMPLE SPECIFICATION

The steam trap shall be a thermodynamic style in a chrome-moly alloy steel body with an integral strainer and optional blowdown valve. Unit shall have an all stainless steel in-line removable seat and disc capsule assembly. Trap shall be capable of installation in any orientation and self-draining when mounted vertically.

INSTALLATION

Trap can be installed in any position; however, horizontal is preferred. Installation should include isolation valves.

MAINTENANCE

Complete replacement of capsule assembly can be performed while the steam trap remains in line. For full maintenance details see Installation and Maintenance Manual.

OPTIONS

Blowdown valve, used for flushing dirt and scale from strainer.

Customized Flanged Connections:

Specify size, face to face dimensions and metallurgy required for application.

WD700HS

The **WD700HS** is the high pressure version of the WD700S.

The standard model **WD700S** will operate over the entire pressure range, however, the **WD700HS** will operate more efficiently and have a longer service life for pressures over 300 PSIG.

WD700S Standard pressure capsule 4-300 PSIG

WD700HS High pressure capsule 150-600 PSIG

WD700S

Thermodynamic Steam Trap

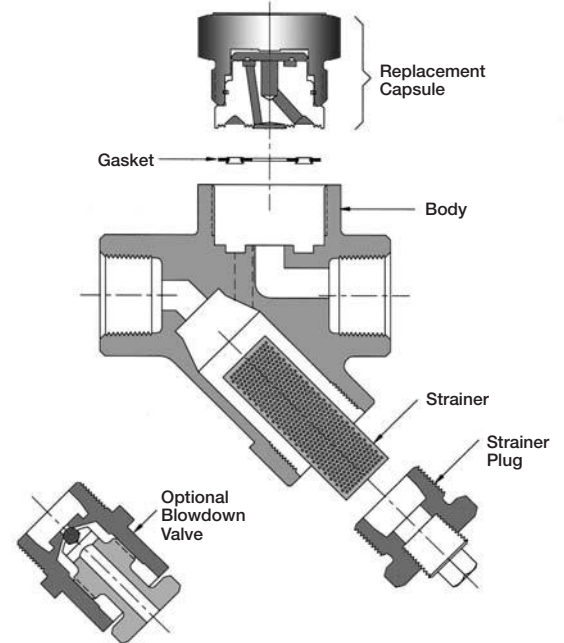
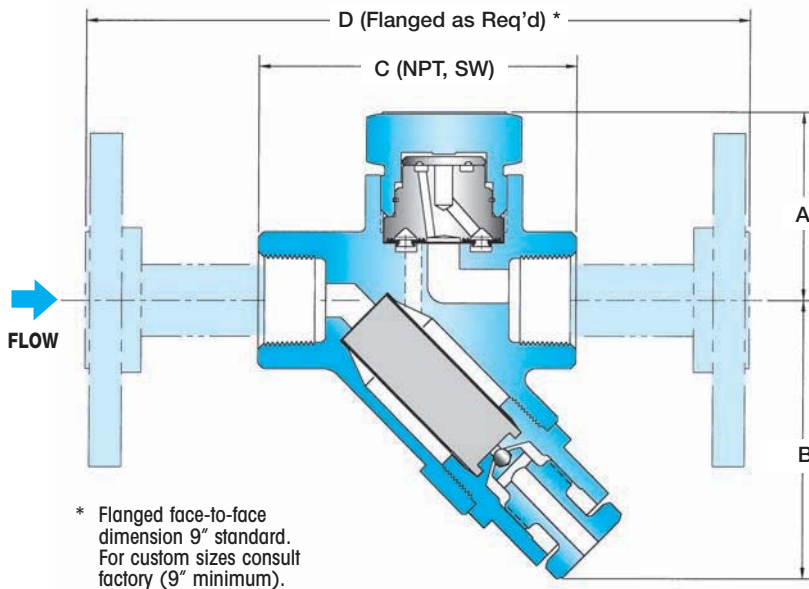

DIMENSIONS & WEIGHTS – inches/pounds

Size/Model	Connection	A	B	C	Weight (lbs)
Series WD700S & WD700HS (Strainer)					
1/2"	NPT, SW	2.04	2.50	3.16	2
3/4"	NPT, SW	2.04	2.50	3.55	2
1"	NPT, SW	2.04	2.50	6.31	2
Series WD700SB & WD700HSB (Strainer & Blowdown Valve)					
1/2"	NPT, SW	2.04	3.06	3.16	2.25
3/4"	NPT, SW	2.04	3.06	3.55	2.25
1"	NPT, SW	2.04	3.06	6.31	2.25

HOW TO SIZE/ORDER

Select working pressure; follow column down to correct capacity (lbs/hr) block. Example:

Application: 275 lbs/hr at 100 PSIG working inlet pressure

Size/Model: **WD700S**, specify pipe size and connections (NPT, SW, FLG)

MATERIALS

Body	Chrome Moly ASTM A-217, GR WC9
Seat	Stainless Steel, 420F
Seat Gasket	Annealed
Cover	Stainless Steel, 416
Disc	Stainless Steel, 420
Retaining Ring	Stainless Steel Spring Wire
Screen	Stainless Steel, 304
Strainer Plug, Pipe Plug	Stainless Steel, 303
Blowdown Valve	Stainless Steel
Flanges	Carbon Steel

CAPACITIES – Condensate (lbs/hr)

Model	Steam Inlet Pressure (PSIG)																						
	1	2	3	4	5	6	7	8	9	10	20	30	40	50	60	80	100	150	200	300	400	500	600
WD700S (Cold)	65	90	110	130	140	160	175	180	190	200	280	350	400	440	500	575	650	800	925	1200	1450	1600	1750
WD700S (Hot)				95	105	115	120	125	130	140	180	220	250	265	280	320	350	405	460	550	600	650	700
WD700HS (Cold)																		350	400	495	500	620	690
WD700HS (Hot)																		250	280	330	380	410	450

Notes: 1) Maximum back pressure not to exceed 80% of inlet pressure (measured in absolute pressure) or trap may not close.
2) For optimum performance, recommended for operating pressure above 10 PSIG.

STEAM TRAPS

WD900S

Thermodynamic Steam Trap

Watson McDaniel reserves the right to change the designs and/or materials of its products without notice.
©2010 Watson McDaniel Company

Model	WD900S/WD900LS
Sizes	1/2", 3/4", 1"
Connections	NPT, SW, 600# FLG
Body Material	Low Carbon Chrome-Moly
Options	Insulation Cap
PMO Max. Operating Pressure	900 PSIG
TMO Max. Operating Temperature	842°F
PMA Max. Allowable Pressure	1500 PSIG @ 100°F
TMA Max. Allowable Temperature	842°F @ 981 PSIG



TYPICAL APPLICATIONS

DRIP: The **WD900S/WD900LS** thermodynamic steam trap is primarily used as a drip trap on high pressure steam mains and steam supply lines. Ideal for outdoor applications that are subject to freezing and for superheated steam conditions.

HOW IT WORKS

The thermodynamic trap has cyclic on-off operation with a disc that is pushed open by incoming condensate and closes tightly when steam tries to escape.

FEATURES

- "Quick-Change" seat and disc for easy in-line repair
- High pressure applications up to 900 PSIG
- Integral strainer to protect trap from contamination
- Hardened stainless steel seat and disc for extended service life even at extremely high pressures
- Single trap model will operate over the entire pressure range (20-900 PSIG)
- Suitable for superheated steam
- Freezeproof when trap is piped in a vertical orientation for complete drainage of condensate
- Trap will function in any orientation (horizontal preferred)

SAMPLE SPECIFICATION

The steam trap shall be a thermodynamic style with body material in chrome-moly alloy steel. Available in size 1/2" and 3/4" Class 600 socket weld ends or flanges. Also available in ANSI 300 FNPT. 1" Unit shall have hardened stainless steel seat and disc with a removable stainless steel strainer.

INSTALLATION

Trap can be installed in any position; however, horizontal is preferred. Installation should include isolation valves.

MAINTENANCE

The complete replacement of seat and disc can be performed while the steam trap remains in line. The strainer should be periodically cleaned to eliminate dirt, which is the most common cause of premature failure. For full maintenance details see Installation and Maintenance Manual.

OPTIONS

Customized Flanged Connections:
Specify size, face-to-face dimensions and metallurgy required for application.

WD900LS

The **WD900LS** is a low capacity version of the standard **WD900S** and recommended for working pressures of 120 PSIG and above.

HOW TO SIZE/ORDER

Select working pressure; follow column down to correct capacity (lbs/hr) block. Example:

Application: 220 lbs/hr at 650 PSIG working inlet pressure
Size/Model: **WD900LS**, specify pipe size and connections

WD900S

Thermodynamic Steam Trap

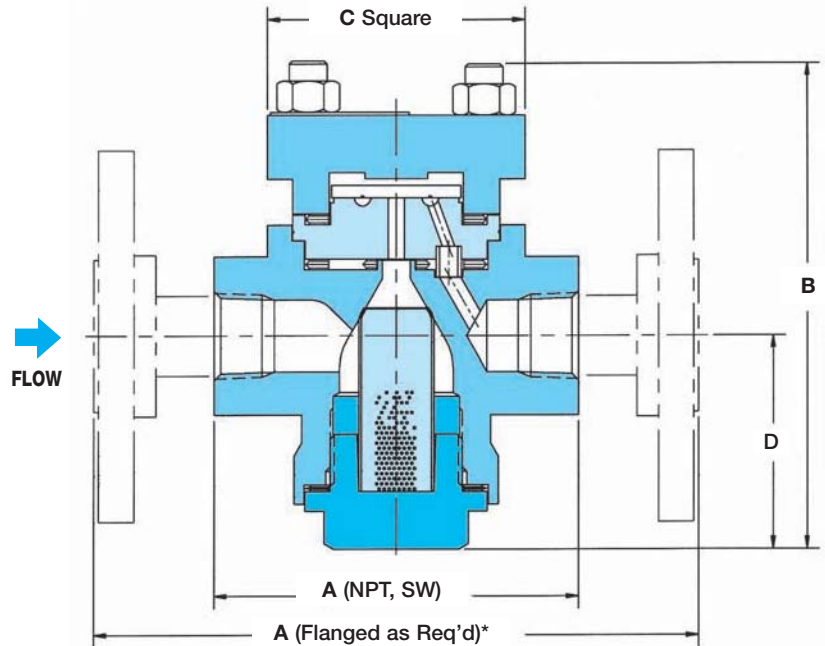
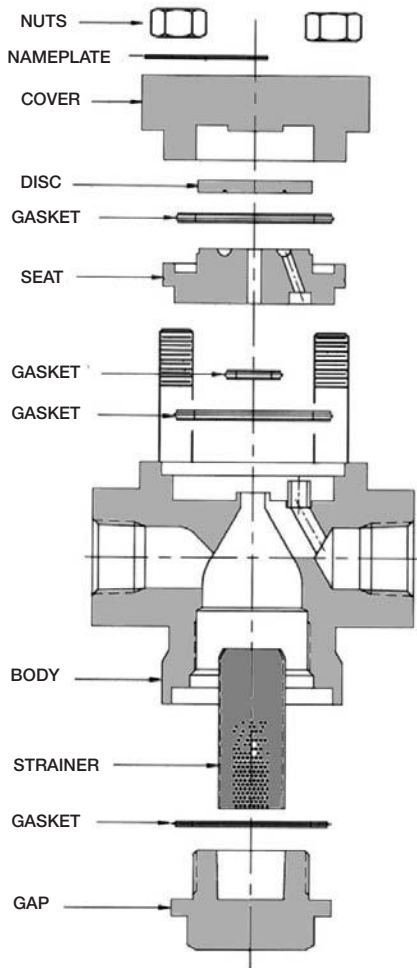

* Flanged face-to-face dimension 9" standard.
For custom sizes consult factory (9" minimum).

DIMENSIONS & WEIGHTS – inches/pounds

Size/Model	Connection	A	B	C	D	Weight (lbs)
1/2" WD900S/WD900LS	NPT, SW	3.6	4.8	2.6	2.1	4.5
1/2" WD900S/WD900LS	*600# FLG	9.0	4.8	2.6	2.1	9.0
3/4" WD900S/WD900LS	NPT, SW	3.6	4.8	2.6	2.1	4.5
3/4" WD900S/WD900LS	*600# FLG	9.0	4.8	2.6	2.1	11.0
1" WD900S/WD900LS	NPT, SW	6.5	4.8	2.6	2.1	4.5
1" WD900S/WD900LS	*600# FLG	9.0	4.8	2.6	2.1	11.0

MATERIALS

Body	Alloy Steel, GR WC9
Seat	Stainless Steel, AISI 420
Cover	Alloy Steel, GR WC9
Strainer Cap	Alloy Steel, GR WC9
Strainer	Stainless Steel, AISI 300
Disc	Stainless Steel, AISI 420
Gasket	Stainless Steel, AISI 304
Studs	SA-193, GR B7
Nuts	SA-194, GR 2H

CAPACITIES – Condensate (lbs/hr)

Model	Steam Inlet Pressure (PSIG)											
	20	50	100	150	200	300	400	500	600	700	800	900
WD900S	243	411	555	641	700	781	835	874	905	930	951	968
WD900LS				181	210	253	290	325	360	381	405	429

- Notes: WD900S:**
- 1) Minimum recommended working pressure: 20 PSIG.
 - 2) Maximum back pressure not to exceed 80% of inlet pressure (measured in absolute pressure) or trap may not close.
- WD900LS:**
- 1) Minimum recommended working pressure: 120 PSIG.
 - 2) Maximum back pressure not to exceed 50% of inlet pressure (measured in absolute pressure) or trap may not close.

STEAM TRAPS

WD3600

High-Pressure Thermodynamic Steam Trap

Watson McDaniel reserves the right to change the designs and/or materials of its products without notice.
©2010 Watson McDaniel Company

Model	WD3600
Sizes	1/2", 3/4", 1"
Connections	BW, SW, 600# FLG, 1500# FLG
Body Material	Forged Alloy Steel
PMO Max. Operating Pressure	3600 PSIG
TMO Max. Operating Temperature	975 °F @ 3600 psi 1025 °F @ 2220 psi
PMA Max. Allowable Pressure	2220 PSIG @ 1025 °F 3600 PSIG @ 975 °F
TMA Max. Allowable Temperature	1025 °F @ 2220 PSIG

Note: Connections may limit Pressure & Temperature ratings.



TYPICAL APPLICATIONS

DRIP, TRACER: The **WD3600** thermodynamic steam trap is commonly used as a drip trap on high-pressure steam mains and steam supply lines. Supplied with an integral strainer to protect the trap from contamination. The internal working mechanism of the WD3600 can be completely replaced while the trap body remains in line. Ideal for outdoor applications that are subject to freezing and for superheated steam conditions.

HOW IT WORKS

The thermodynamic trap has cyclic on-off operation with a disc that is pushed open by incoming condensate and closes tightly when steam tries to escape.

FEATURES

- "Quick-Change" seat and disc for easy in-line repair
- High pressure applications up to 3600 PSIG
- Integral strainer to protect trap from contamination
- Hardened stainless steel seat and disc for extended service life even at extremely high pressures
- Steam trap model will operate over the entire pressure range (100-3600 PSIG)
- Suitable for superheated steam
- Freezeproof when trap is piped in a vertical orientation for complete drainage of condensate
- Trap will function in any orientation (horizontal preferred)

SAMPLE SPECIFICATION

The steam trap shall be a thermodynamic style with body material in forged alloy steel. Available in size 1/2", 3/4" and 1" Socket Weld, Butt Weld ends or ANSI 600# & 1500# RF flanged connections. Unit shall have hardened repairable stainless steel seat and disc with a removable stainless steel sintered strainer.

INSTALLATION

Trap can be installed in any position; however, horizontal is preferred. Installation should include isolation valves.

MAINTENANCE

Complete replacement of seat and disc can be performed while the steam trap remains in line. For full maintenance details see Installation and Maintenance Manual.

OPTIONS

Customized Flanged Connections:
Specify size, face to face dimensions and metallurgy required for application. Trap includes strainer. Blowdown option is NOT available.

WD3600

High-Pressure Thermodynamic Steam Trap

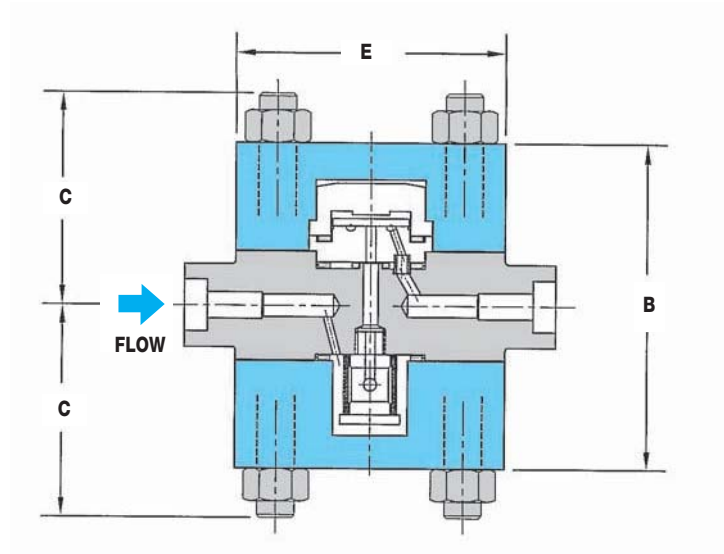
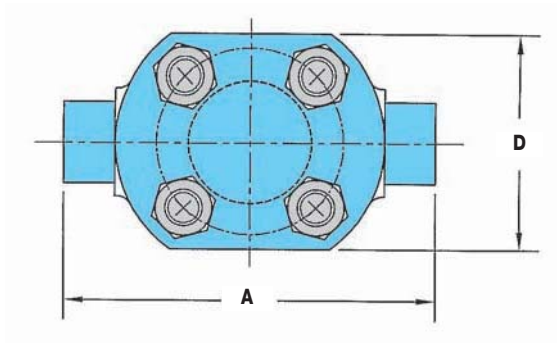

DIMENSIONS & WEIGHTS – inches/pounds						
Size/Model	A	B	C	D	E	Weight (lbs)
1/2", 3/4", 1" WD3600	6.3	5.4	3.5	3.6	4.5	25

MATERIALS	
Body	Forged Alloy Steel, ASTM 182 F22
Seat	Stainless Steel, AISI 420
Cover, top & bottom	Forged Alloy Steel, ASTM 182 F22
Strainer	Sintered Stainless Steel, AISI 300
Disc	Stainless Steel, AISI 420
Gasket	Stainless Steel, AISI 304
Studs	SA-193, GR B16
Nuts	SA-194, GR 4

HOW TO SIZE/ORDER
Select working pressure; follow column down to correct capacity (lbs/hr) block. Example:
Application: 380 lbs/hr at 1000 PSIG working inlet pressure
Size/Model: WD3600 , Specify pipe size and connections (BW, SW, 600# FLG, 1500# FLG)

Model	CAPACITIES – Condensate (lbs/hr)													
	Steam Inlet Pressure (PSIG)													
	100	500	1000	1250	1750	2000	2250	2500	2750	3000	3250	3500	3600	3600
WD3600	165	290	380	400	435	470	500	525	550	575	595	610	620	625

Note: Maximum back pressure not to exceed 50% of inlet pressure (measured in absolute pressure) or trap may not close.

STEAM TRAPS

WT1000

Thermostatic Steam Trap

Watson McDaniel reserves the right to change the designs and/or materials of its products without notice.
©2010 Watson McDaniel Company

Model	WT1000
Sizes	1/2", 3/4"
Connections	NPT
Body Material	Stainless Steel
PMO Max. Operating Pressure	300 PSIG
TMO Max. Operating Temperature	Saturated Steam Temperature
PMA Max. Allowable Pressure	1032 PSIG @ 100°F
TMA Max. Allowable Temperature	750°F @ 800 PSIG



TYPICAL APPLICATIONS

DRIP, TRACER: The **WT1000** thermostatic steam trap was specifically designed for drip and tracing applications as well as an air vent for heat exchangers. Like all thermostatic traps, the WT1000 is small, light, and has excellent air handling capabilities. The discharging of air on start-up allows steam to enter the system more quickly.

HOW IT WORKS

The thermostatic trap contains a welded stainless steel thermal element that expands when heated and contracts when cooled. When air and condensate are present the trap is in the open discharge position. When steam reaches the trap the element expands and closes off tightly.

FEATURES

- Excellent air handling capability which allows steam to enter and the system to warm up faster; extremely important during start up
- Welded stainless steel thermal element which resists shock from water hammer
- Freezeproof when trap is installed in a vertical orientation allowing for complete condensate drainage
- Body is produced from solid stainless steel barstock

SAMPLE SPECIFICATION

The steam trap shall be of thermostatic type with stainless steel body and stainless steel thermal element.

INSTALLATION & MAINTENANCE

Trap can be installed in any position. Steam trap is non-repairable. If new trap is needed, remove from line and replace.

OPTIONS

Special bellows available upon request.

MATERIALS

Trap Housing	Stainless Steel, AISI 304L
Thermal Element	Stainless Steel, 300 Series
Valve	Stainless Steel, AISI 440C

HOW TO SIZE/ORDER

Select working pressure, follow column down to correct capacity (lbs/hr) block. Example:

Application: 435 lbs/hr at 100 PSIG working inlet pressure
Size/Model: **WT1000**, Specify pipe size and connections (1/2", 3/4")

DIMENSIONS – inches

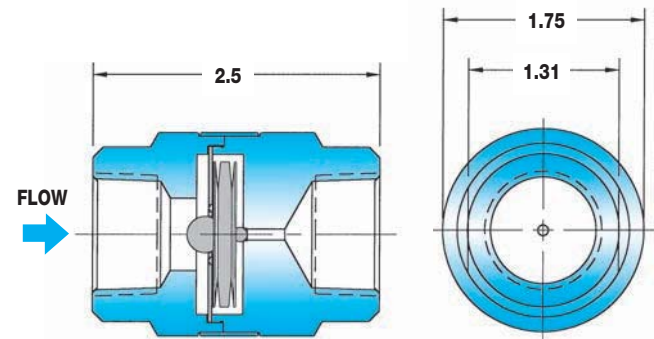

CAPACITIES – Condensate (lbs/hr)

MODEL	Steam Inlet Pressure (PSIG)									
	5	10	20	50	100	125	150	200	250	300
WT1000	95	140	195	305	435	485	530	610	685	750

Back Pressure as Percentage of Inlet Pressure	10	20	25	30	40	50	60	70	80	90
Percentage of Decrease in Trap Capacity	0	0	0	2	5	12	20	30	40	55

WT2500

Thermostatic Steam Trap

Model	WT2500
Sizes	1/2", 3/4"
Connections	NPT
Body Material	Cast Iron
PMO Max. Operating Pressure	250 PSIG
TMO Max. Operating Temperature	406°F
PMA Max. Allowable Pressure	250 PSIG up to 450°F
TMA Max. Allowable Temperature	450°F @ 250 PSIG

TYPICAL APPLICATIONS

DRIP, TRACER, PROCESS: The **WT2500** thermostatic steam trap is used for drip, tracing and process applications. Their compact size, excellent air handling capability and wide operating pressure range make them a great choice for most applications. Thermostatic traps are far superior to bucket traps and thermodynamic disc traps in their ability to remove air from the system.

HOW IT WORKS

The thermostatic trap contains a welded stainless steel thermal element that expands when heated and contracts when cooled. When air and condensate are present, the trap is in the open discharge position. When steam reaches the trap, the element expands and closes off tightly.

FEATURES

- The thermal element and seat can be easily removed and replaced in minutes with the trap body still in-line
- Operates at steam pressures up to 250 PSIG
- Thermostatic traps have excellent air handling capability allowing air to be discharged rapidly and steam to enter the system quickly during start up
- Welded stainless steel thermal element that resists shock from water hammer
- Freezeproof when trap is installed in a vertical orientation allowing for complete condensate drainage
- Hardened stainless steel seat for extended service life

MATERIALS

Cover & Body	Cast Iron ASTM A-126 Class B
Thermal Element	Stainless Steel, AISI 302
Valve & Seat	Stainless Steel, AISI 416
Cover Gasket	Garlock

CAPACITIES – condensate (lbs/hr)

Model	Orifice Size	Steam Inlet Pressure (PSIG)								
		5	10	20	50	100	125	150	200	250
WT2501	3/16"	441	625	882	1391	1827	1969	2095	2305	2483
WT2503	5/16"	903	1271	1811	2861	3754	4043	4300	4730	5093

- Notes:**
- 1) 5/16" orifice size is standard and is normally used on process equipment.
 - 2) 3/16" orifice size is offered for reduced capacity and normally used for tracing applications.



Units: Inches

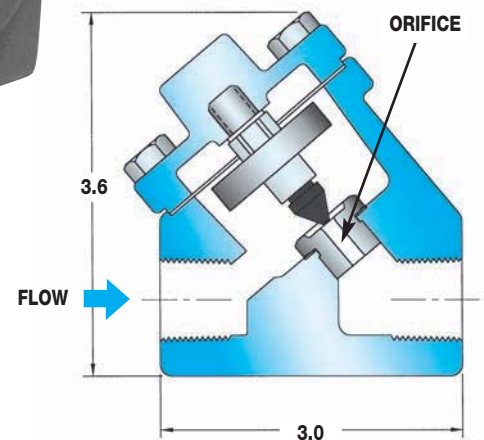

SAMPLE SPECIFICATION

The steam trap shall be of a thermostatic type with cast iron body and stainless steel thermal element. Trap must be in-line repairable with a bolt-on type cover that is sealed with a spiral wound Stainless Steel AISI 316 gasket. Valve and seat to be hardened stainless steel.

MAINTENANCE & INSTALLATION

Trap can be installed in any position. If replacement is required, remove the cover and replace the internal working components. Repair kit includes thermal element, seat and gasket. For full maintenance details see Installation and Maintenance Manual.

OPTION

Fail-closed bellows available upon request.

SLR = Steam lock release

HOW TO SIZE/ORDER

Select working pressure; follow column down to correct capacity (lbs/hr) block. Example:

Application: 1827 lbs/hr at 100 PSIG working inlet pressure
 Size/Model: **WT2501**, 3/16" orifice, Specify pipe size (1/2", 3/4")

STEAM TRAPS

WT2000C

Thermostatic Steam Trap

Watson McDaniel reserves the right to change the designs and/or materials of its products without notice.
©2010 Watson McDaniel Company

Model	WT2000C
Sizes	1/2", 3/4"
Connections	NPT
Body Material	Stainless Steel
PMO Max. Operating Pressure	650 PSIG
TMO Max. Operating Temperature	Saturated Steam Temp.
PMA Max. Allowable Pressure	1032 PSIG @ 100°F
TMA Max. Allowable Temperature	750°F @ 800 PSIG



TYPICAL APPLICATIONS

DRIP, TRACER, PROCESS: The **WT2000C** thermostatic steam trap is used for drip, tracing, and process applications. Their compact size, all stainless steel construction, excellent air handling capabilities, and the ability to operate over a wide pressure range make them a good choice for most applications. They can also be used as an air vent on heat exchangers. Thermostatic traps are far superior to bucket traps and thermodynamic traps in their ability to remove air from the system. The discharging of air on start up allows steam to enter the system more quickly.

HOW IT WORKS

The thermostatic trap contains a welded stainless steel thermal element that expands when heated and contracts when cooled. When air and condensate are present the trap is in the open discharge position. When steam reaches the trap the element expands and closes off tightly.

FEATURES

- **Thermostatic traps have excellent air handling capability allowing air to be discharged rapidly and steam to enter the system quickly during start up**
- **Integral strainer to protect trap from contamination**
- **Welded stainless steel thermal element which resists shock from water hammer**
- **Freezeproof when trap is installed in a vertical orientation allowing for complete condensate drainage**
- **Body is produced from stainless steel investment casting**
- **Hardened stainless steel seat for extended service life**
- **Will operate at steam pressures up to 650 PSIG**

SAMPLE SPECIFICATION

Steam trap shall be of thermostatic type with stainless steel body, thermal element, internal screen, and hardened valve and seat.

INSTALLATION

Isolation valves should be installed with trap. Trap can be installed in any position.

MAINTENANCE

Steam trap is non-repairable. If failure or malfunction occurs, remove and replace.

OPTIONS

Fail-closed bellows available upon request.

SLR = Steam lock release

WT2000C

Thermostatic Steam Trap

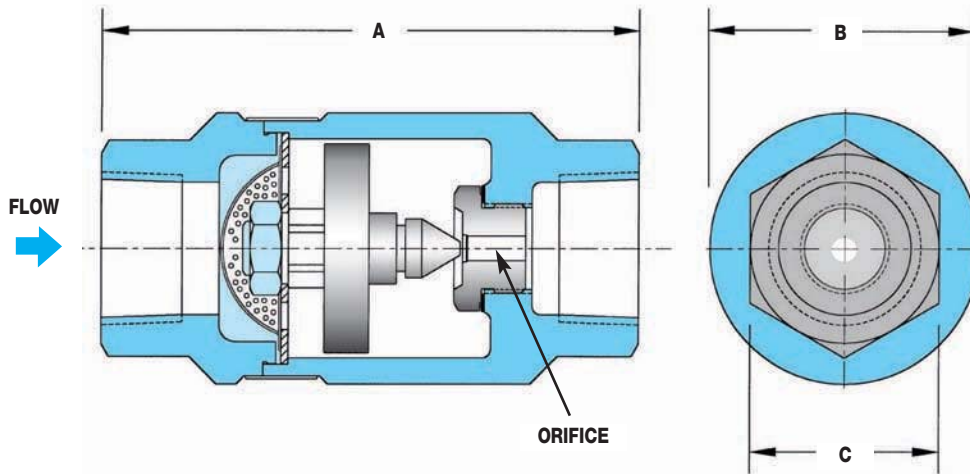

DIMENSIONS & WEIGHTS – inches/pounds				
Size	A	B	C	Weight (lbs)
1/2", 3/4"	3.75	1.88	1.31	1.5

MATERIALS

Trap Housing	Stainless Steel, ASTM A351-CF3
Thermal Element	Stainless Steel
Valve & Seat	Stainless Steel, AISI 416
Strainer Screen	Stainless Steel

HOW TO SIZE/ORDER

Select working pressure; follow column down to correct capacity (lbs/hr) block. Example:

Application: 1827 lbs/hr at 100 PSIG working inlet pressure
 Size/Model: **WT2001C**, 3/16" orifice, Specify connection size

CAPACITIES – Condensate (lbs/hr)

Model	Orifice Size	Steam Inlet Pressure (PSIG)															
		5	10	20	50	100	125	150	200	250	300	350	400	450	500	600	650
WT2001C	3/16"	441	625	882	1391	1827	1969	2095	2305	2483	2636	2777	2903	3019	3129	3323	3413
WT2003C	5/16"	903	1271	1811	2861	3754	4043	4300	4730	5093	5413	5702	5959	6195	6421	6820	7004

- Notes: 1) 5/16" orifice size is standard and is normally used on process equipment.
 2) 3/16" orifice size is offered for reduced capacity and normally used for tracing applications.

Back Pressure as Percentage of Inlet Pressure	10	20	25	30	40	50	60	70	80	90
Percentage Decrease in Trap Capacity	0	0	0	2	5	12	20	30	40	55

STEAM TRAPS

WT3000

Thermostatic Steam Trap (Repairable)

Watson McDaniel reserves the right to change the designs and/or materials of its products without notice.
©2010 Watson McDaniel Company

Model	WT3000
Sizes	1/2", 3/4"
Connections	NPT, SW, FLG
Body Material	Stainless Steel
Options	Strainer, Blowdown Valve
PMO Max. Operating Pressure	650 PSIG
TMO Max. Operating Temperature	Saturated Steam Temp.
PMA Max. Allowable Pressure	906 PSIG @ 100°F
TMA Max. Allowable Temperature	750°F @ 725 PSIG



TYPICAL APPLICATIONS

PROCESS: The **WT3000** thermostatic steam trap is used for industrial process applications. Their compact size, all stainless steel construction, excellent air handling capability and wide operating pressure range make them a great choice for most process applications. Thermostatic traps are far superior to bucket traps and thermodynamic disc traps in their ability to remove air from the system.

HOW IT WORKS

The thermostatic trap contains a welded stainless steel thermal element that expands when heated and contracts when cooled. When air and condensate are present, the trap is in the open discharge position. When steam reaches the trap, the element expands and closes off tightly.

FEATURES

- The thermal element and seat can be easily removed and replaced in minutes with the trap body still in-line
- Operates at steam pressures up to 650 PSIG
- Thermostatic traps have excellent air handling capability allowing air to be discharged rapidly and steam to enter the system quickly during start up
- Welded stainless steel thermal element that resists shock from water hammer
- Freezeproof when trap is installed in a vertical orientation allowing for complete condensate drainage
- Body is produced from stainless steel investment casting
- Hardened stainless steel seat for extended service life
- Available with integral strainer and blowdown valve

SAMPLE SPECIFICATION

The steam trap shall be of a thermostatic type with stainless steel body, thermal element and internal strainer. Trap must be in-line repairable with a bolt-on type cover that is sealed with a spiral wound Stainless Steel AISI 316 gasket. Seat and valve to be hardened stainless steel.

INSTALLATION

Isolation valves should be installed with trap. Trap can be installed in any position.

MAINTENANCE

If the trap fails, remove the cover and replace the internal working components. Repair kit includes thermal element, seat and gasket. For full maintenance details see Installation and Maintenance Manual.

OPTIONS

Strainer, blowdown valve, and steam lock release.

S = Strainer (**WT3001S**)

SB = Strainer and blowdown valve (**WT3001SB**)

SLR = Steam lock release

Fail-closed Bellows

Special Bellows

For additional sub-cooling of condensate (down to 43°F below saturated steam temperature)

Note: Standard bellows are designed for approximately 5°F sub-cool temperature

HOW TO SIZE/ORDER

Refer to the Capacity Chart to determine which model is required to satisfy the condensate load. (Select steam inlet pressure, follow column down to correct capacity (lbs/hr) block) Example:

Application: 3754 lbs/hr at 100 PSIG steam inlet pressure
Size/Model: **WT3003S**, 5/16" orifice with strainer,
Specify size & connections (NPT, SW, FLG)

Add **S** to end of the model code if a Strainer is required

Add **SB** to end of the model code if a Strainer & Blowdown Valve is required

Examples:

3/4" WT3003S 3/4" connections with strainer, 5/16" orifice

1/2" WT3001SB 1/2" connections with strainer and blowdown valve, 3/16" orifice

WT3000

Thermostatic Steam Trap

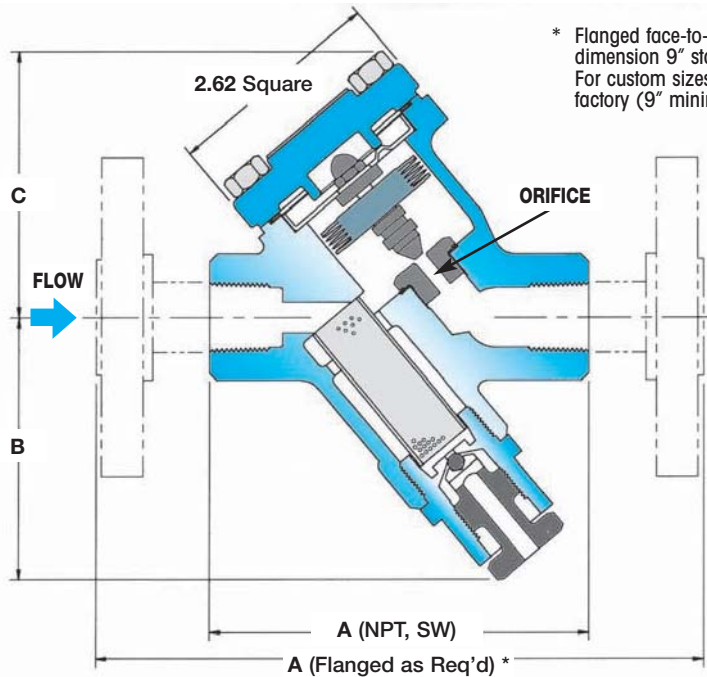

* Flanged face-to-face dimension 9" standard. For custom sizes consult factory (9" minimum).

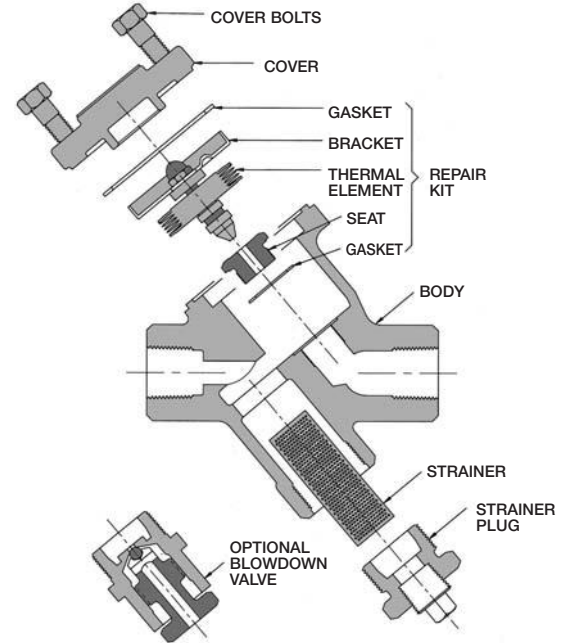

DIMENSIONS & WEIGHTS – inches/pounds					
Size	Connection	A	B	C	Weight (lbs)
Series WT3000, WT3000S (Strainer)					
1/2"	NPT, SW	4.5	2.57	3.13	4.5
3/4"	NPT, SW	4.5	2.57	3.13	4.5
Series WT3000SB (Strainer & Blowdown Valve)					
1/2"	NPT, SW	4.5	3.2	3.13	4.5
3/4"	NPT, SW	4.5	3.2	3.13	4.5

S = Strainer only SB = Strainer and Blowdown

MATERIALS	
Cover & Body	Stainless Steel, AISI 316L
Thermal Element	Stainless Steel, AISI 300
Valve & Seat	Stainless Steel, AISI 416
Cover Gasket	Stainless Steel, AISI 316
Seat Gasket	Stainless Steel, AISI 316
Cover Bolts	Steel, ASTM A193 GR B7 Nickel Plated
Screen*	0.046 Perforated Stainless Steel AISI 304
Blowdown Valve*	Stainless Steel AISI 303

* Screen and blowdown valve are optional

CAPACITIES – Condensate (lbs/hr)																		
Model	Pipe Size	Orifice Size	Steam Inlet Pressure (PSIG)															
			5	10	20	50	100	125	150	200	250	300	350	400	450	500	600	650
WT3001	1/2", 3/4"	3/16"	441	625	882	1391	1827	1969	2095	2305	2483	2636	2777	2903	3019	3129	3323	3413
WT3003		5/16"	903	1271	1811	2861	3754	4043	4300	4730	5093	5413	5702	5959	6195	6421	6820	7004

Notes: 1) 5/16" orifice size is standard and is normally used on process equipment.
 2) 3/16" orifice size is offered for reduced capacity.
 3) 5/64" low capacity orifice is available upon request.

Back Pressure as Percentage of Inlet Pressure	10	20	25	30	40	50	60	70	80	90
Percentage Decrease in Trap Capacity	0	0	0	2	5	12	20	30	40	55

STEAM TRAPS

WT4000

Thermostatic Steam Trap (Repairable)

Watson McDaniel reserves the right to change the designs and/or materials of its products without notice.
©2010 Watson McDaniel Company

Model	WT4000
Sizes	3/4", 1"
Connections	NPT, SW, FLG
Body Material	Stainless Steel
Options	Strainer, Blowdown Valve
PMO Max. Operating Pressure	300 PSIG
TMO Max. Operating Temperature	Saturated Steam Temperature
PMA Max. Allowable Pressure	906 PSIG @ 100°F
TMA Max. Allowable Temperature	750°F @ 725 PSIG

**TYPICAL APPLICATIONS**

PROCESS: The **WT4000** thermostatic steam trap is used for industrial process applications. Their compact size, all stainless steel construction, excellent air handling capability and wide operating pressure range make them a great choice for most process applications. Thermostatic traps are far superior to bucket traps and thermodynamic disc traps in their ability to remove air from the system.

HOW IT WORKS

The thermostatic trap contains a welded stainless steel thermal element that expands when heated and contracts when cooled. When air and condensate are present, the trap is in the open discharge position. When steam reaches the trap, the element expands and closes off tightly.

FEATURES

- The thermal element and seat can be easily removed and replaced in minutes with the trap body still in-line
- Operates at steam pressures up to 300 PSIG
- Thermostatic traps have excellent air handling capability allowing air to be discharged rapidly and steam to enter the system quickly during start up
- Welded stainless steel thermal element that resists shock from water hammer
- Freezeproof when the trap is installed in a vertical orientation allowing for complete condensate drainage
- Body is produced from stainless steel investment casting
- Hardened stainless steel seat for extended service life
- Available with integral strainer and blowdown valve

SAMPLE SPECIFICATION

The steam trap shall be of thermostatic type with stainless steel body, thermal element, and internal strainer. Trap must be in-line repairable with a bolt-on type cover that is sealed with a spiral wound Stainless Steel AISI 316 gasket. Seat and valve to be hardened stainless steel.

INSTALLATION

Isolation valves should be installed with trap. Trap can be installed in any position.

MAINTENANCE

If trap fails, remove cover and replace the internal working components. Repair kit includes thermal element, seat and gasket. For full maintenance details see Installation and Maintenance Manual.

OPTIONS

Strainer, blowdown valve, and steam lock release.

S = Strainer (**WT4001S**)

SB = Strainer and blowdown valve (**WT4001SB**)

SLR = Steam lock release

Customized flanged connections: Specify size, face-to-face dimensions and metallurgy required for application.

HOW TO SIZE/ORDER

Refer to the Capacity Chart to determine which model is required to satisfy the condensate load. (Select steam inlet pressure; follow column down to correct capacity (lbs/hr) block) Example:

Application: 5610 lbs/hr at 100 PSIG steam inlet pressure

Size/Model: **WT4001S**, 5/16" orifice with strainer, Specify size & connections (NPT, SW, FLG)

Add **S** to end of model code if a Strainer is required

Add **SB** to end of model code if a Strainer & Blowdown Valve is required

Examples:

3/4" WT4001S 3/4" connections with strainer, 5/16" orifice

1" WT4003SB 1" connections with strainer and blowdown valve, 7/16" orifice

WT4000

Thermostatic Steam Trap

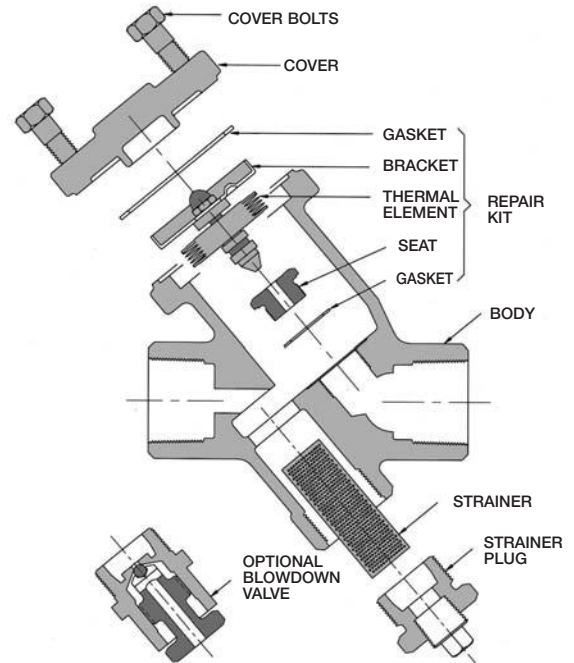
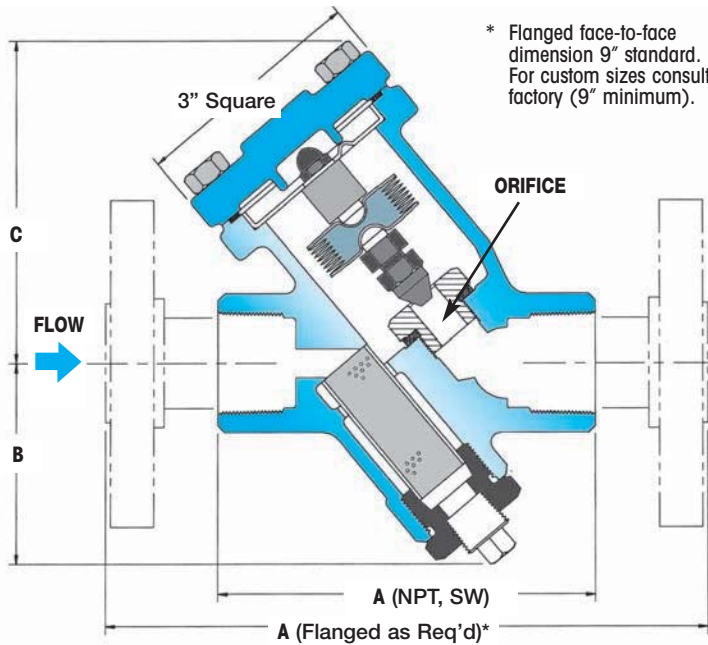

DIMENSIONS & WEIGHTS – inches/pounds					
Size	Connection	A	B	C	Weight (lbs)
Series WT4000, WT4000S (Strainer)					
3/4"	NPT, SW	4.81	2.57	4.12	4.5
1"	NPT, SW	4.81	2.57	4.12	4.5
Series WT4000SB (Strainer & Blowdown Valve)					
3/4"	NPT, SW	4.81	3.12	4.12	4.5
1"	NPT, SW	4.81	3.12	4.12	4.5

S = Strainer only SB = Strainer and Blowdown

MATERIALS	
Body	Stainless Steel, AISI 316L
Cover	Stainless Steel, AISI 316L
Cover Gasket	Spiral Wound Stainless Steel, AISI 316
Cover Bolts	Steel, ASTM A193 GR B7 Nickel Plated
Thermal Element	Stainless Steel, AISI 302
Valve & Seat	Hardened Stainless Steel, AISI 416
Seat Gasket	Stainless Steel, AISI 316
Screen*	0.046 Perforated Stainless Steel AISI 304
Blowdown Valve*	Stainless Steel AISI 300

* Screen and blowdown valve are optional

CAPACITIES – Condensate (lbs/hr)														
Model	Pipe Size	Orifice Size	Steam Inlet Pressure (PSIG)											
			1	2	5	10	20	50	100	125	150	200	250	300
WT4001	3/4", 1"	5/16"	605	855	1350	1910	2705	4275	5610	6045	6425	7070	7615	8095
WT4003		7/16"	940	1325	2095	2960	4190	6620	8695	9365	9950	10955	11800	12540

Notes: 1) 7/16" orifice size is standard and is normally used on process equipment.
2) 5/16" orifice size is offered for reduced capacity.

Back Pressure as Percentage of Inlet Pressure	10	20	25	30	40	50	60	70	80	90
Percentage Decrease in Trap Capacity	0	0	0	2	5	12	20	30	40	55

STEAM TRAPS

WT5000

Adjustable Discharge Temperature Steam Trap

Watson McDaniel reserves the right to change the designs and/or materials of its products without notice.
©2010 Watson McDaniel Company

Model	WT5000
Sizes	3/8", 1/2", 3/4, 1"
Connections	NPT, SW
Body Material	Stainless Steel
PMO Max. Operating Pressure	650 PSIG
TMO Max. Operating Temperature	662°F
PMA Max. Allowable Pressure	900 PSIG
TMA Max. Allowable Temperature	800°F

TYPICAL APPLICATIONS

TRACER: The **WT5000** Series Bimetal Steam Trap is used in steam tracing applications (process lines, instrumentation and winterization, general steam jacketing) and small process applications where accurate control of condensate discharge temperature is required to utilize the sensible heat of the condensate.

HOW IT WORKS

Bimetallic plates of dissimilar metals respond to steam temperature variations, whereby the metals are relaxed at relatively cool conditions (such as start-up) and the trap is open for the discharge of condensate. As temperature nears the preset subcool temperature below saturation, the metals react and expand, closing the trap and preventing the loss of live steam. External field adjustability of the bimetal element allows precise control of the condensate discharge temperature.

The condensate temperature can be field adjusted as follows:

To **INCREASE** the temperature, turn the adjuster screw:
COUNTERCLOCKWISE

To **DECREASE** the temperature, turn the adjuster screw:
CLOCKWISE

Note: The lower the set temperature, the more condensate will back-up in front of the trap inlet connection. Therefore, consideration should be given to providing adequate piping to accommodate any such back-up.

FEATURES

- Excellent for various steam tracing and small process applications using the sensible heat of condensate
- Field adjustable bimetal element allows precise control of condensate discharge temperature
- Internal screen and seat/plug design help prevent pipe scale and debris from accumulating on seating surfaces to provide trouble-free operation
- In-line repairable



SAMPLE SPECIFICATION

The steam trap shall be of thermostatic type with stainless steel body, seat, valve plug and bimetallic element. Bimetal element shall be externally adjustable for control of condensate discharge temperature. Trap must be in-line repairable with a replaceable bimetal element, valve plug and seat.

INSTALLATION

Isolation valves should be installed with trap. Trap can be installed in any position.

MAINTENANCE

If trap fails, remove cover and replace the internal working components. Repair kit includes bimetallic element (including valve stem and plug), seat and gasket. For full maintenance details see Installation and Maintenance Manual.

WT5000

Adjustable Discharge Temperature Steam Trap

Units: inches

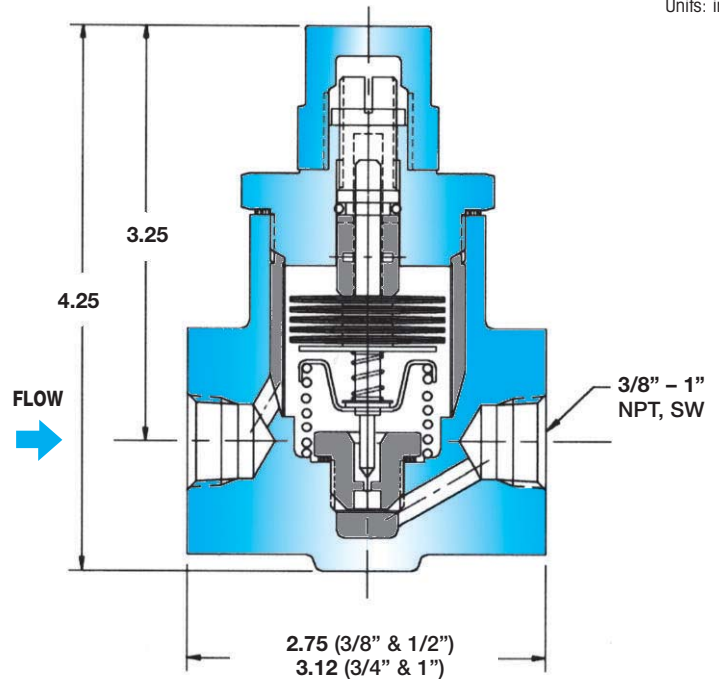
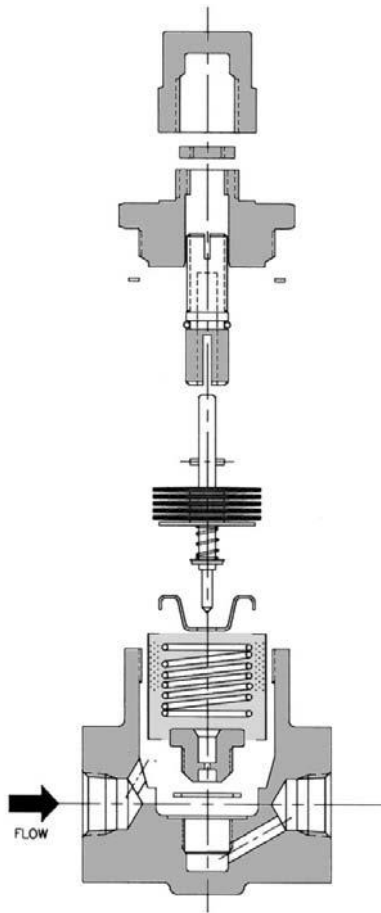

MATERIALS

Body and Cover	304 Stainless Steel
Bimetal Element	GB14
Valve Seat	420 Stainless Steel
Gaskets	A240 S31600
Valve Stem	420 Stainless Steel

HOW TO SIZE/ORDER

From the chart below, confirm that application capacity requirements are satisfied at the working Inlet Pressure and desired Set and Discharge Temperatures. Example:

Application: Discharge of 300 lbs/hr at a working inlet pressure of 125 PSIG and 240°F set temperature

Size/Model: **WT5000**, Specify pipe size (3/8", 1/2", 3/4", 1") and connections (NPT, SW)

Note: WT5000 trap can pass up to 336 lbs/hr of condensate at a working inlet pressure of 125 PSIG and condensate set temperature of 240°F (see Capacity Chart).

Maximum Trap Capacities at Various Inlet Pressures and Set Temperatures – Condensate (lbs/hr)

Set Temperature	Steam Inlet Pressure (PSIG)														
	15	30	50	100	125	150	200	250	300	350	400	450	500	600	650
220°F	56	70	102	144	161	177	204	228	250	270	289	306	323	354	368
240°F	116	164	212	300	336	368	425	475	520	562	600	637	671	735	756
260°F	134	190	245	346	387	424	490	548	600	648	693	735	775	849	883
280°F	143	202	261	370	413	453	523	584	640	691	739	784	826	905	942

- Notes:
- 1) Capacities in chart are based on discharging condensate to atmosphere with a condensate temperature of 200°F.
 - 2) Maximum discharge capacity up to 970 lbs/hr, depending on operating condition requirements.
 - 3) Contact factory for additional information including other condensate set and discharge temperatures.
 - 4) To ensure proper operation and eliminate possible steam loss, the Set Temperature should be lower than 27°F subcool (degrees below inlet steam saturation temperature).

STEAM TRAPS

TT25B/TT125

Thermostatic Steam Trap (Repairable)

Watson McDaniel reserves the right to change the designs and/or materials of its products without notice.
©2010 Watson McDaniel Company

Model	TT25B, TT125
Sizes	1/2", 3/4"
Connections	NPT
Body Material	Brass
PMO Max. Operating Pressure	TT25B 25 PSIG TT125 125 PSIG
TMO Max. Operating Temperature	Saturated Steam Temperature
PMA Max. Allowable Pressure	125 PSIG up to 450°F
TMA Max. Allowable Temperature	450°F @125 PSIG

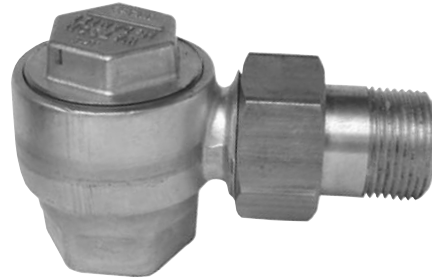

TYPICAL APPLICATIONS

TT25B/TT125 thermostatic steam traps are predominantly used in the HVAC industry. They are referred to as radiator traps because the quick-disconnect right angle connection is found on most radiator installations. Their excellent air handling capabilities, compact size, and economical cost make them a great choice for air vents on heat exchangers or for steam trap applications on OEM equipment.

HOW IT WORKS

The thermostatic trap contains a welded stainless steel thermal element that expands when heated and contracts when cooled. When air and condensate are present the trap is in the open discharge position. When steam reaches the trap the element expands and closes off tightly.

FEATURES

- Excellent air handling capability
- In-line repairable
- Welded stainless steel thermal element
- Stainless seat on TT125
- High thermal efficiency

SAMPLE SPECIFICATION

The steam trap shall be of thermostatic type with brass or bronze body and stainless steel thermal element. Trap must be in-line repairable.

INSTALLATION

Isolation valves should be installed with trap. Trap can be installed in any position.

MAINTENANCE

If the trap fails, remove the cover and replace the internal working components. Repair kit includes thermal element, seat and gasket. For full maintenance details see Installation and Maintenance Manual.

STEAM TRAPS

TT25B/TT125

Thermostatic Steam Trap

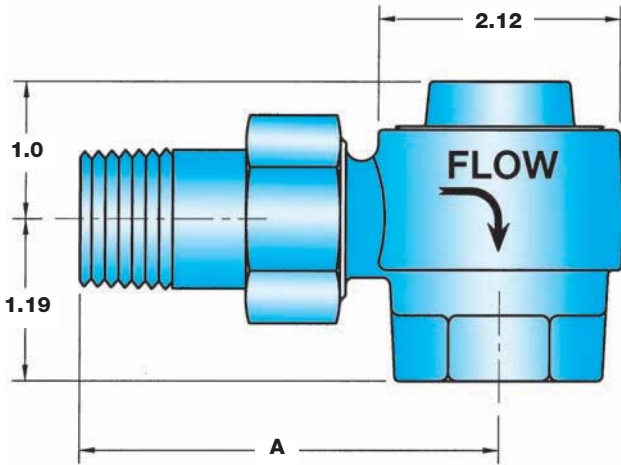

DIMENSIONS & WEIGHTS – inches/pounds

Model	Pipe Size	A	Weight (lbs)
TT25B, TT125	1/2"	2.1875	1.5
TT25B, TT125	3/4"	3.062	1.5

Note: Other Union Connections and Lengths are available; consult factory.

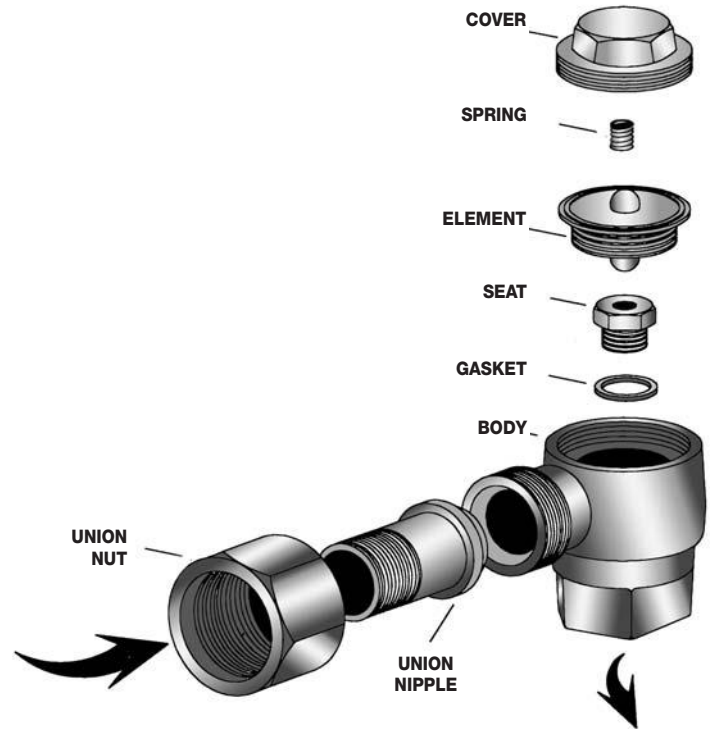

HOW TO SIZE/ORDER

Select differential pressure; follow column down to correct capacity (lbs/hr) block. Example:

Application: 2100 lbs/hr at 40 PSI differential pressure

Size/Model: 3/4" TT125

CAPACITIES – Condensate (lbs/hr)

Pipe Size	Differential Pressure (PSI)				
	15	25	40	65	125
1/2"	825	1070	1323	1610	1950
3/4"	1290	1700	2100	2575	3300

MATERIALS

Body	Forged Brass, CA 377
Element	Welded Stainless Steel, AISI 302
Cover	Forged Brass, CA 377
Spring	Stainless Steel, AISI 304
Seat	TT25B: Brass ASTM B-21 TT125: Stainless Steel, AISI 303
Gasket	Brass, ASTM B-21
Union Nipple	Brass, ASTM B-16
Union Nut	Brass, ASTM B-16

STEAM TRAPS

FT Series

Float & Thermostatic Steam Trap

Watson McDaniel reserves the right to change the designs and/or materials of its products without notice.
©2010 Watson McDaniel Company

Model	FT
Sizes	3/4", 1", 1 1/4", 1 1/2", 2"
Connections	NPT
Body Material	Cast Iron
PMO Max. Operating Pressure	75 PSIG
TMO Max. Operating Temperature	Saturated Steam Temperature
PMA Max. Allowable Pressure	75 PSIG up to 450°F
TMA Max. Allowable Temperature	450°F @ 75 PSIG



TYPICAL APPLICATIONS

DRIP, PROCESS: The **FT Series** float and thermostatic steam traps are used for HVAC and light industrial process applications, and can be applied to unit heaters, water heaters, pressing machines, heat exchangers, and coils. These traps have excellent air removal capability making them an excellent choice for HVAC and process applications requiring quick start-up.

HOW IT WORKS

Float and thermostatic steam traps have a float and thermostatic element that work together to remove both condensate and air from the steam system. The float, which is attached to a valve, rises and opens the valve when condensate enters the trap. Air is discharged through the thermostatic air vent to the outlet side of the trap. The thermostatic air vent closes when steam enters the trap.

FEATURES

- **H-pattern design allows piping from either side of the steam trap (there are two inlet ports at top and two outlet ports at bottom)**
- **Float & Thermostatic traps have excellent air handling capability allowing air to be discharged rapidly and steam to enter the system quickly during start up**
- **Welded stainless steel thermostatic air vent resists shock from water hammer**
- **In-line repairable (all internals are attached to cover)**

SAMPLE SPECIFICATION

The trap shall be of float and thermostatic design with cast iron body. Thermostatic element to be welded stainless steel. Float and seating material to be stainless steel. Trap must be in-line repairable.

INSTALLATION

Isolation valves should be installed with trap. The trap must be level and upright for the float mechanism to operate.

MAINTENANCE

All internal components can be replaced with the trap body in-line. Repair kit includes thermostatic element, valve seat and disc, float and sealing gasket. For full maintenance details see Installation and Maintenance Manual.

FT Series

Float & Thermostatic Steam Trap

DIMENSIONS & WEIGHTS – inches/pounds

Model	A	B	C	D	E	Weight (lbs)
FT-3, FT-4, FT-33 FT-34, FT-73, FT-74	4.125	5.00	5.125	3.125	2.75	7.50
FT-6, FT-35, FT-36 FT-75, FT-76	5.00	6.81	6.47	4.125	3.43	13.0
FT-7, FT-37L, FT-77L	6.375	7.68	8.218	5.25	4.41	21.0
FT-8, FT-38, FT-78 FT-S8-15, FT-S8-75	6.50	11.0	8.968	7.468	4.531	40.0

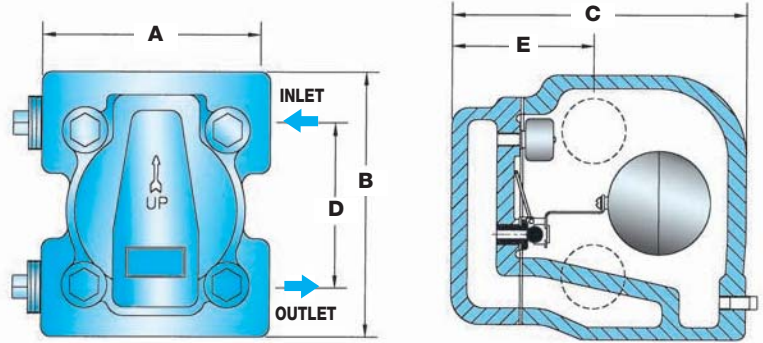

HOW TO SIZE/ORDER

From the capacity chart, select the model that can handle the working pressure of the system (PMO). Select the trap that will meet the capacity requirements at the differential pressure. Example:

Application: 1700 lbs/hr at 30 PSIG working pressure and 5 PSI differential pressure

Size/Model: 1" **FT-35** or 1 1/4" **FT-36**

MATERIALS

Body & Cover	Cast Iron, ASTM A-126 Class B
Nuts & Bolts	High-Tensile Steel
Gasket	Grafoil
Float	Stainless Steel
Valve & Seat	Stainless Steel
Thermostatic Assembly	Stainless Steel Bellows & Valve

CAPACITIES – Condensate (lbs/hr)

Model	PMO (PSIG)	Pipe Size	Orifice Size	Differential Pressure (PSI)																		
				1/4	1/2	1	2	3	5	10	15	20	25	30	40	50	60	75	90	100	125	
FT-3	15	3/4"	9/32"	340	440	600	830	990	1280	1790	2150											
FT-4	15	1"	9/32"	340	440	600	830	990	1280	1790	2150											
FT-6	15	1 1/4"	9/32"	850	1100	1460	2000	2350	2950	4000	4800											
FT-7	15	1 1/2"	1/2"	1300	1700	2050	2550	2900	3500	4400	5300											
FT-8	15	2"	21/32"	2500	3150	4000	5700	6100	6800	8300	9800											
FT-S8-15	15	2"	15/16"	4400	5850	7400	9200	10300	12600	15300	18100											
FT-33	30	3/4"	11/64"	220	300	405	530	650	890	1210	1485	1705	1865	2010								
FT-34	30	1"	11/64"	220	300	405	530	650	890	1210	1485	1705	1865	2010								
FT-35	30	1"	1/4"	450	600	880	1205	1420	1845	2560	3230	3715	4100	4405								
FT-36	30	1 1/4"	1/4"	450	600	880	1205	1420	1845	2560	3230	3715	4100	4405								
FT-37L	30	1 1/2"	7/16"	600	800	1200	1680	2210	2600	3500	4500	5200	5700	6100								
FT-38	30	2"	13/32"	1550	2045	2625	3560	4260	5660	7890	9440	10500	11360	12095								
FT-73	75	3/4"	9/64"	140	195	265	360	430	580	770	990	1110	1210	1290	1430	1560	1680	1830				
FT-74	75	1"	9/64"	140	195	265	360	430	580	710	990	1110	1210	1290	1430	1560	1680	1830				
FT-75	75	1"	#16	270	360	485	660	780	1020	1430	1740	1980	2200	2420	2670	2910	3135	3370				
FT-76	75	1 1/4"	#16	270	360	485	660	780	1020	1430	1740	1980	2200	2420	2670	2910	3135	3370				
FT-77L	75	1 1/2"	5/16"	340	460	690	900	1200	1400	1900	2350	2700	3000	3250	3750	4150	4500	4700				
FT-78	75	2"	5/16"	800	1075	1300	1700	2000	2600	3750	4350	4700	5050	5400	5960	6500	6950	7550				
FT-S8-75	75	2"	13/32"	1360	1800	2100	2800	3300	4300	6300	7300	8000	8500	9000	10000	11000	11600	12500				

STEAM TRAPS

FT600 & FT601 Series

Float & Thermostatic Steam Trap

Watson McDaniel reserves the right to change the designs and/or materials of its products without notice.
©2010 Watson McDaniel Company

Model	FT600 & FT601*
Sizes	3/4", 1", 1 1/2", 2", 3", 4"
Connections	NPT, SW, FLG
Body Material	Carbon Steel or 316SS
Options	Live Orifice Air Vent
PMO Max. Operating Pressure	450 PSIG
TMO Max. Operating Temperature	750°F
PMA Max. Allowable Pressure	990 PSIG @ 100°F
TMA Max. Allowable Temperature	750°F @ 670 PSIG

* **FT601 Body Material is 316 SS**
FT600 Body Material is Carbon Steel

TYPICAL APPLICATIONS

PROCESS The **FT600 & FT601 Series** high-pressure float and thermostatic steam traps are primarily used on industrial process applications. The excellent air handling capabilities of float and thermostatic traps make them a better choice than bucket traps for applications requiring quick system start-up. These traps have in-line pipe connections. Used in chemical plants and petrochemical refineries on reboilers, heat exchangers, and other critical process applications. Model FT601 is identical to FT600 except body material is 316 SS.

HOW IT WORKS

Float and thermostatic steam traps have a float and thermostatic element that work together to remove both condensate and air from the steam system. The float, which is attached to a valve, rises and opens the valve when condensate enters the trap. Air is discharged through the thermostatic air vent to the outlet side of the trap. The thermostatic air vent closes when steam enters the trap.

FEATURES

- Investment cast steel body and cover with class 400 shell rating (670 PSIG @ 750°F)
- Hardened stainless steel seat and disc for extended service life even at extreme temperatures and pressures
- In-line repairability is simplified by having all internals attached to the cover. Studded cover allows for easier removal of body.
- Welded stainless steel air vent resists shock from water hammer. Live orifice air vent is available for superheated applications
- F & T traps discharge condensate immediately as it is formed (No condensate will back up into the system)

SAMPLE SPECIFICATION

The steam trap shall be of the mechanical float type having cast steel bodies, horizontal in-line connections in NPT, SW, or flanged, and all stainless steel internals. Incorporated into the trap body shall be an all stainless steel welded thermal element air vent which is water hammer resistant. The air vent is to be located at the high point of trap body to assure proper venting of non-condensables. The trap body will be in-line renewable. All bodies and covers shall be class 400 shell design, suitable for 670 PSIG @ 750°F.

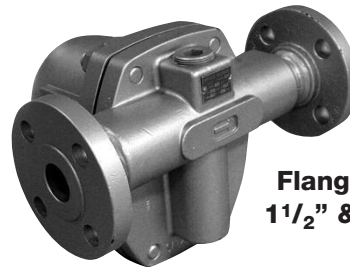
**1 1/2" & 2"****3/4" & 1"****Flanged
1 1/2" & 2"****INSTALLATION**

Installation should include a strainer and isolation valves for maintenance purposes.

MAINTENANCE

Trap is in-line repairable. Studs are permanently installed into the cover simplifying the replacement of internal components.

OPTIONS

Live orifice air vent for superheated applications.

MATERIALS

FT 600: Body & Cover	Cast Steel, ASTM A-216
FT 601: Body & Cover	316 SS
Cover Studs	Steel, AS 193, GR B7
Cover Nuts	Steel, SA 194, GR 2H
Cover Gasket	Stainless Steel Reinforced Grafoil
Valve Assembly	Stainless Steel, AISI 431
Gasket, Valve Assembly	Stainless Steel Reinforced Grafoil
Pivot Assembly	Stainless Steel, 17-4 PH
Mounting Screws	Stainless Steel Hex Head, 18-8
Float	Stainless Steel, ASTM -240, 304
Air Vent Assembly	Thermostatic element 304 SS Optional: Live orifice

FT600 & FT601 Series

Float & Thermostatic Steam Trap

FT600 & FT601: 3/4", 1", 1 1/2", 2"

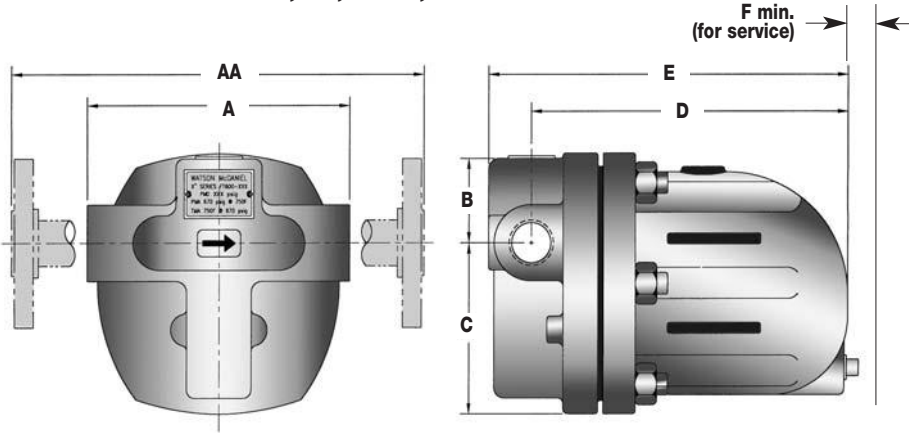

DIMENSIONS & WEIGHTS – inches/pounds									Weight (lbs)	
Model*	Size	A	AA	B	C	D	E	F	NPT/SW	FLG
									FT600	3/4"
FT600	1"	6.50	10.40	2.50	5.50	8.44	9.50	6.25	31	36
FT600	1 1/2"	9.80	14.00	3.26	6.85	10.40	11.94	7.75	82	91
FT600	2"	11.80	16.00	3.60	7.40	11.59	13.27	8.00	93	107

* Chart is applicable for both Models FT600 & FT601

HOW TO SIZE/ORDER

From the capacity chart, select the model that can handle the working pressure of the system (PMO). Select the trap that will meet the capacity requirements at the differential pressure. Example:

Application: 1690 lbs/hr at 30 PSIG working pressure and 5 PSI differential pressure
 Size/Model: 1" FT600-65-14 (65 PSIG max), Specify connections (NPT, SW, FLG)

CAPACITIES – Condensate (lbs/hr)		Differential Pressure (PSI)																					
Model*/ (PSIG)	PMO Sizes	Differential Pressure (PSI)																					
		1	2	3	4	5	6	8	10	20	30	40	50	65	80	100	145	200	300	400	450		
FT600-65-13	3/4"	225	300	363	413	463	500	575	635	960	1060	1180	1320	1460									
FT600-65-14	1"	775	1094	1340	1520	1690	1865	2125	2370	3260	3990	4500	5000	5500									
FT600-65-16	1 1/2"	2500	3450	4130	4750	5300	5875	6750	7500	10625	13125	15000	16800	18850									
FT600-65-17	2"	8500	11950	14670	16800	18700	20100	23650	25250	35900	43000	49600	55500	61250									
FT600-145-13	3/4"	137	180	218	250	275	297	340	380	520	625	725	863	895	995	1120	1315						
FT600-145-14	1"	400	555	660	755	850	925	1060	1237	1593	1925	2240	2490	2750	3000	3430	3935						
FT600-145-16	1 1/2"	1275	1750	2125	2430	2740	2930	3370	3750	5100	6250	7200	7995	8875	9900	11250	13300						
FT600-145-17	2"	3125	4400	5375	6250	6900	7100	8700	9250	14625	16875	19375	21875	25000	27500	31000	37000						
FT600-200-13	3/4"	93	137	160	187	205	227	260	287	400	487	560	610	710	775	875	1060	1250					
FT600-200-14	1"	300	410	487	560	610	660	750	925	1140	1375	1520	1687	1875	2060	2312	2750	3100					
FT600-300-13	3/4"	50	68	83	95	106	118	137	155	197	240	275	300	340	375	413	490	570	710				
FT600-300-14	1"	225	300	363	413	463	500	575	635	960	1060	1180	1320	1468	1640	1815	2130	2550	3000				
FT600-450-13	3/4"	32	42	49	56	62	67	76	84	119	145	163	175	192	210	186	275	312	375	425	450		
FT600-450-14	1"	137	180	218	250	275	297	340	380	520	625	725	863	895	995	1120	1315	1500	1870	2125	2250		
FT600-450-16	1 1/2"	825	1130	1400	1570	1760	1937	2190	2500	3375	4125	4740	5250	6000	6600	7300	8650	10200	12600	14375	15200		
FT600-450-17	2"	1560	2187	2800	3100	3490	3750	4300	4800	6750	8250	9500	10625	12400	13700	15000	18120	21200	26250	28700	31250		

Note: For 450 Model, the Thermostatic Air Vent is replaced with a live Orifice.

* Chart is applicable for both Models FT600 & FT601

STEAM TRAPS

FT600 & FT601 Series

Watson McDaniel reserves the right to change the designs and/or materials of its products without notice.
©2010 Watson McDaniel Company

Float & Thermostatic Steam Trap

FT600 & FT601: 3" & 4"

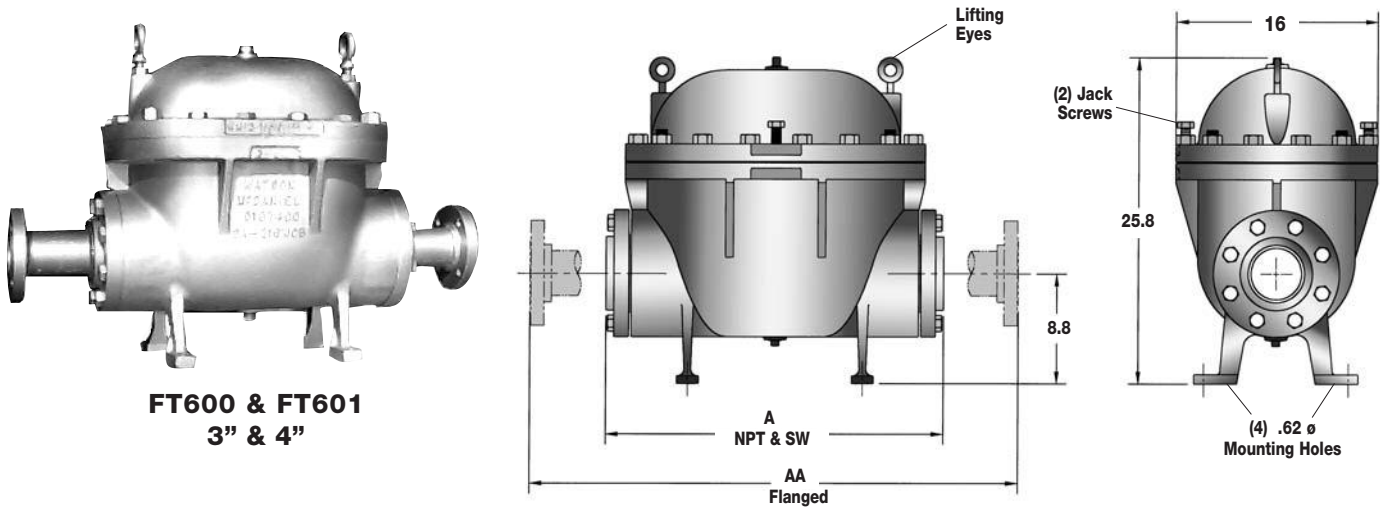

DIMENSIONS & WEIGHTS – inches/pounds

Model*	Size	A	AA	Weight (lbs)	
				NPT/SW	FLG
FT600	3"	27	39	587	626
FT600	4"	N/A	39	N/A	654

* Chart is applicable for both Models FT600 & FT601

CAPACITIES – Condensate (1000 lbs/hr)

Temp	Differential Pressure (PSI)																				
	1/2	1	2	5	10	15	20	30	40	50	75	100	125	150	175	200	250	300	350	400	450
COLD*	44	59	81	122	170	205	230	280	317	350	425	480	540	580	625	670	740	800	860	910	960
HOT	44	53	64	83	100	112	121	138	149	159	177	190	201	212	222	230	247	260	270	280	290

* Cold Water capacities are to be used when the trap is used as a liquid drain trap.
Note: For liquid drain trap applications, please specify "liquid drain trap" when ordering.

CAPACITY CORRECTION FACTORS

To obtain capacity with a liquid other than water, multiply water capacity by correction factor.

Spec. Gravity	1	.98	.96	.94	.92	.90	.88	.86	.84	.82	.80	.75	.70	.65	.60	.55	.50
Corr. Factor	1	.990	.980	.970	.959	.949	.938	.927	.917	.906	.894	.866	.837	.806	.775	.742	707

PRESSURE-TEMPERATURE RATING - 3" & 4" Models

PMA 650 PSIG up to 450°F
TMA 750°F @ 375 PSIG

FT600 & FT601 Series

Float & Thermostatic Steam Trap

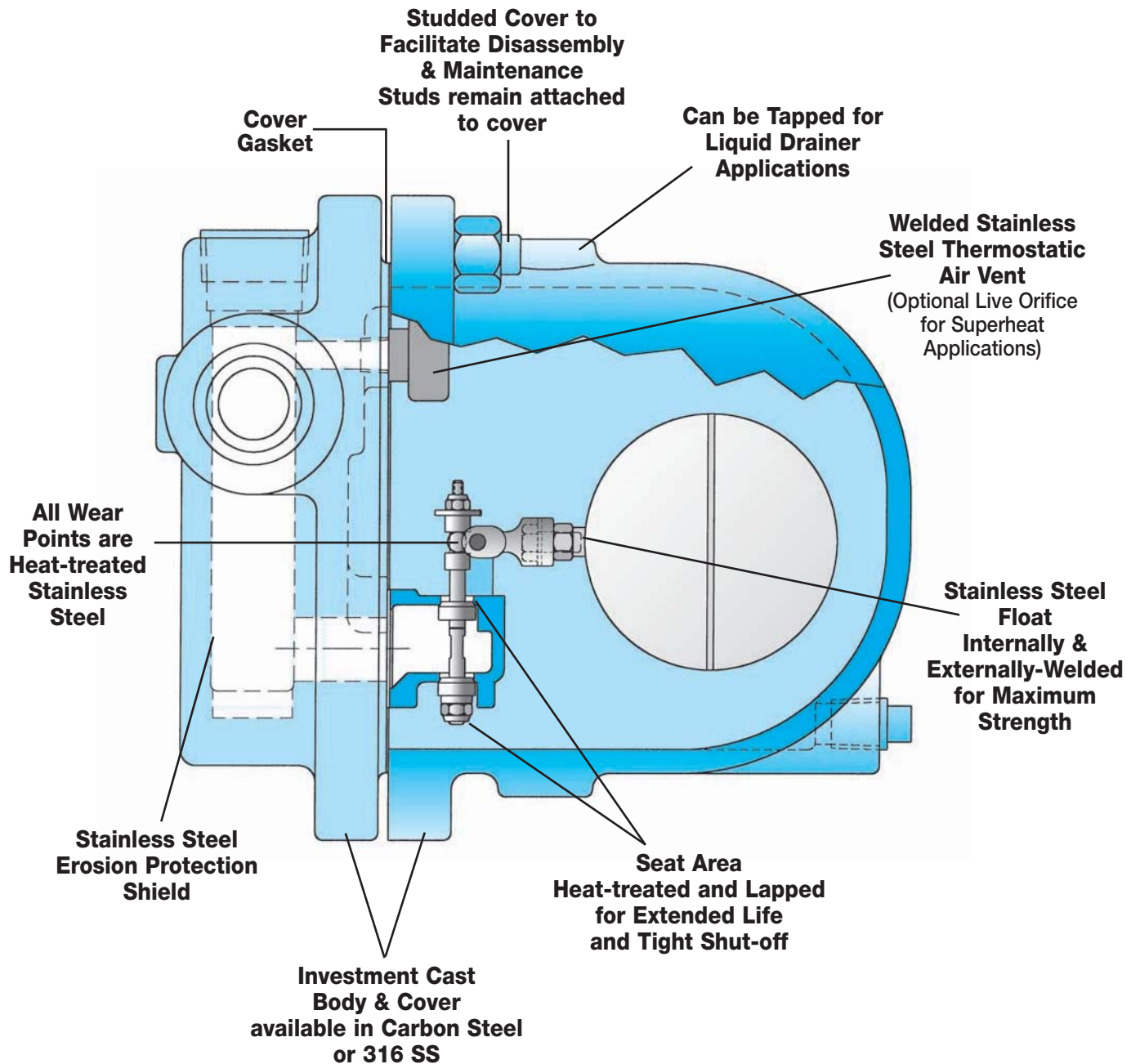

STEAM TRAPS

FTE & FTES Series

Float & Thermostatic Steam Trap

Watson McDaniel reserves the right to change the designs and/or materials of its products without notice.
©2010 Watson McDaniel Company

Model	FTE	FTES
Sizes	1 1/2", 2", 2 1/2"	2 1/2"
Connections	NPT	NPT, SW, FLG
Body Material	Ductile Iron	Cast Steel
PMO Max. Operating Pressure	200 PSIG	300 PSIG
TMO Max. Operating Temperature	450°F	450°F
PMA Max. Allowable Pressure	300 PSIG up to 450°F	300 PSIG up to 750°F
TMA Max. Allowable Temperature	450°F @ 300 PSIG	750°F @ 300 PSIG



TYPICAL APPLICATIONS

PROCESS: The **FTE & FTES Series** float and thermostatic steam traps are used in HVAC and on industrial process equipment with very high load requirements. These high capacity steam traps are typically used on reboilers, absorption chillers, large air handling coils, large heat exchangers, and other large process equipment.

HOW IT WORKS

Float and thermostatic steam traps have a float and thermostatic element that work together to remove both condensate and air from the steam system. The float, which is attached to a valve, rises and opens the valve when condensate enters the trap. Air is discharged through the thermostatic air vent to the outlet side of the trap. The thermostatic air vent closes when steam enters the trap.

FEATURES

- Ductile Iron has a higher pressure and temperature rating and is more resistant to shock loads than Cast Iron.
- Cast Steel Body will allow operating pressures and temperatures up to 300 PSIG and 450°F.
- High Capacity steam trap for draining large process equipment (over 100,000 lbs/hr)
- All stainless steel internals with hardened seat and wear parts
- In-line repairable is simplified by having all internals attached to the cover
- Welded stainless steel thermostatic air vent resists shock from water hammer. Live orifice air vent is available for superheated applications
- Excellent air handling capability allowing air to be discharged rapidly and steam to enter the system quickly during start up
- F & T traps discharge condensate immediately as it is formed (No condensate will back up into the system)

SAMPLE SPECIFICATION

The trap shall be of float and thermostatic design with ductile iron or cast steel body. The trap must incorporate all stainless steel internals with hardened seat and welded stainless steel thermostatic air vent. Trap must be in-line repairable.

INSTALLATION

Isolation valves should be installed with trap to facilitate maintenance. The trap must be level and upright for the float mechanism to operate. Larger traps should not be supported by the piping system alone. Trap must be sized and located properly in the steam system.

MAINTENANCE

All working components can be replaced with the trap body remaining in-line. Repair kits include thermostatic air vent, float, valve seat and disc, and gaskets. For full maintenance details see Installation and Maintenance Manual.

OPTIONS

Live orifice air vent for superheated steam applications.

Parallel-pipe inlet/outlet connections are standard as shown. An optional In-line inlet/outlet connection is available;

FTE & FTES Series

Float & Thermostatic Steam Trap

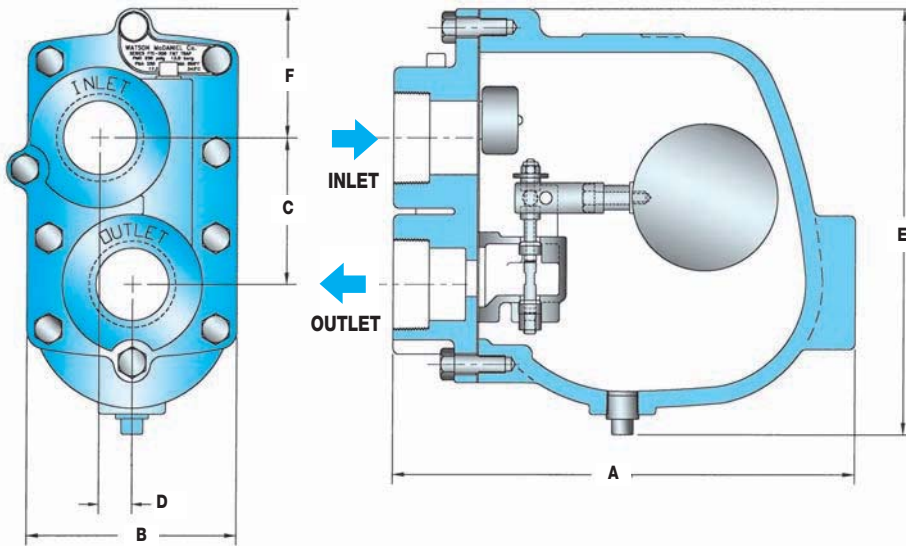

DIMENSIONS & WEIGHTS – inches/pounds

Size/Model	A	B	C	D	E	F	Weight
2" FTE-20	12.6	5.7	4.5	0.5	11.1	3.9	54
2" FTE-50	16.0	8.4	7.3	1.4	15.6	3.6	146
2½" FTE-50	15.5	8.4	7.3	1.4	15.6	3.6	140
2½" FTE-125	15.5	8.4	7.3	1.4	15.6	3.6	146
1½" FTE-200	9.6	4.3	3.0	0.7	8.8	2.6	35
2" FTE-200	12.6	5.7	4.5	0.5	11.1	3.9	65
2½" FTE-200	15.5	8.4	7.3	1.4	15.6	3.6	146
2½" FTES-300	15.5	8.4	7.3	1.4	15.6	3.6	146

Note: 2½" FTES-50, 125 & 200 have same dimensions and capacities as FTE-50, 125 & 200.

MATERIALS

Body & Cover (FTE)	Ductile Iron
Body & Cover (FTES)	Cast Steel, ASTM A-216
Cover Screw	Grade 5 Carbon Steel
Cover Gasket	Grafoil
Valve Discs	Stainless Steel, AISI 17-4PH
Main Valve Assembly Housing	Stainless Steel, AISI 17-4PH
Valve Assembly Gasket	Garlock
Ball Float	Stainless Steel, AISI 304
Thermostatic Vent	Stainless Steel, AISI 300 Optional: Live orifice air vent

HOW TO SIZE/ORDER

From the capacity chart, select the model that can handle the working pressure of the system (PMO). Select the trap that will meet the capacity requirements at the differential pressure. Example:

Application: 2,700 lbs/hr at 150 PSIG working pressure and 1/4 PSI differential pressure

Size/Model: 2" FTE-200, NPT connections

CAPACITIES – Condensate (lbs/hr)

Model	PMO (PSIG)	Pipe Size	Orifice Size	Differential Pressure (PSI)																																								
				1/4	1/2	1	2	5	10	15	20	30	40	50	75	100	125	200	250	300																								
FTE-20*	20	2"	.937"	6100	7800	9300	11800	15900	19500	22500	26000																																	
FTE-50	50	2"	2.125"	12800	16900	20100	25300	33000	40200	43500	46000	47800	50500	52500																														
FTE-50	50	2½"	2.125"	20400	25700	31000	37000	46300	55100	60300	65100	72000	77300	82100																														
FTE-125	125	2½"	2.125"	20400	25700	31000	37000	46300	55100	60300	65100	72000	77300	82100	90400	97700	105000																											
FTE-200	200	1½"	.375"	950	1350	1900	2200	2700	3300	3900	4400	5300	5800	6400	7600	8500	9400	11900																										
FTE-200	200	2"	.75"	2700	4100	5700	7400	9900	11800	13400	14400	16400	18000	19000	21500	23000	24500	29200																										
FTE-200	200	2½"	1.5"	7200	12300	17400	21500	27600	32600	36000	39300	43100	46600	49200	54700	58800	61900	74000																										
FTES-300	300	2½"	1.5"	7200	12300	17400	21500	27600	32600	36000	39300	43100	46600	49200	54700	58800	61900	74000	86000	100550																								

* Single seat orifice. All others are double seated.

STEAM TRAPS

FTT Series

Float & Thermostatic Steam Trap

Watson McDaniel reserves the right to change the designs and/or materials of its products without notice.
©2010 Watson McDaniel Company

Model	FTT
Sizes	1/2", 3/4", 1", 1 1/2", 2"
Connections	NPT
Body Material	Ductile Iron
PMO Max. Operating Pressure	300 PSIG
TMO Max. Operating Temperature	Saturated Steam Temperature
PMA Max. Allowable Pressure	300 PSIG up to 450°F
TMA Max. Allowable Temperature	450°F @ 300 PSIG



TYPICAL APPLICATIONS

DRIP, PROCESS: The **FTT Series** float and thermostatic steam traps are used in drip and process applications, industrial and HVAC process equipment. The excellent air handling capabilities of float and thermostatic traps make them a better choice than bucket traps for applications requiring quick system start-up. These traps have in-line pipe connections. Used on unit heaters, textile machines, heat exchangers, and other medium sized process equipment.

HOW IT WORKS

Float and thermostatic steam traps have a float and thermostatic element that work together to remove both condensate and air from the steam system. The float, which is attached to a valve, rises and opens the valve when condensate enters the trap. Air is discharged through the thermostatic air vent to the outlet side of the trap. The thermostatic air vent closes when steam enters the trap.

SAMPLE SPECIFICATION

The trap shall be of float and thermostatic design with ductile iron body and in-line piping configuration. Thermostatic air vent to be welded stainless steel. All internals must be stainless steel with hardened seat area. Trap must be in-line repairable.

INSTALLATION

The trap must be level and upright for the float mechanism to operate. Trap must be sized and located properly in the steam system.

MAINTENANCE

All internal components can be replaced with the trap body remaining in-line. Repair kits include thermostatic air vent, float, valve seat and disc, and gaskets. For full maintenance details see Installation and Maintenance Manual.

OPTIONS

Live orifice air vent for superheated steam applications.

FEATURES

- **Ductile Iron has a higher pressure and temperature rating and is more resistant to shock loads than cast Iron**
- **All stainless steel internals with hardened seat and wear parts**
- **In-line repairability is simplified by having all internals attached to the cover**
- **Welded stainless steel thermostatic air vent resists shock from water hammer. Live orifice air vent is available for superheated applications**
- **Excellent air handling capability allowing air to be discharged rapidly and steam to enter the system quickly during start-up.**
- **F & T traps discharge condensate immediately as it is formed (No condensate will back-up into the system)**

FTT Series

Float & Thermostatic Steam Trap

FTT 1/2" & 3/4"

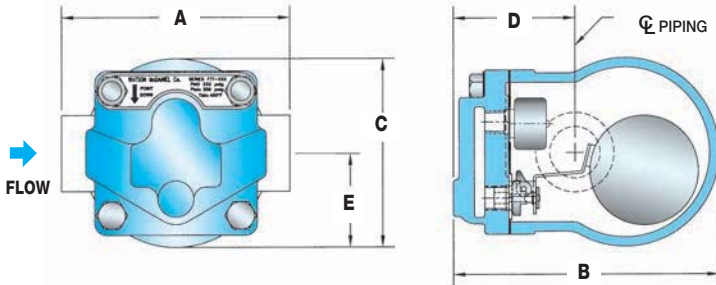

FTT 1"

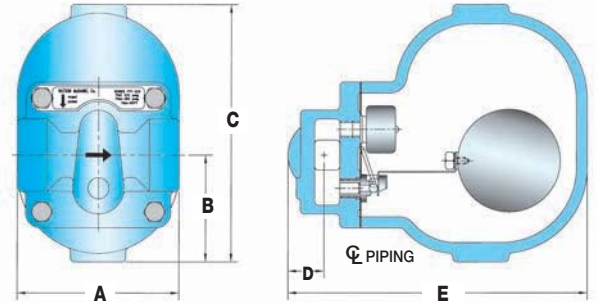

FTT 1 1/2" & 2"

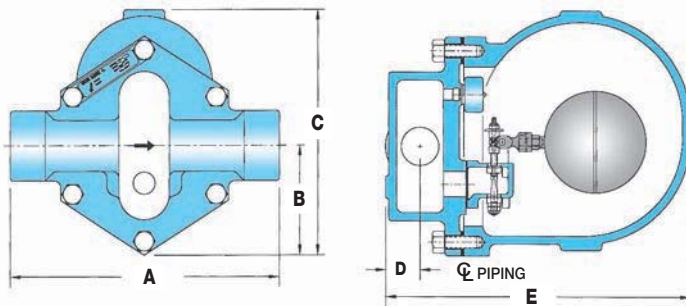

DIMENSIONS & WEIGHTS – inches/pounds

Size	A	B	C	D	E	Weight
1/2", 3/4"	4.8	1.9	3.9	2.5	5.5	6
1"	4.8	3.1	7.5	1.1	8.8	16
1 1/2"	10.6	4.3	9.6	1.4	12.0	40
2"	11.9	4.3	9.6	1.4	12.0	40

HOW TO SIZE/ORDER

From the capacity chart, select the model that can handle the working pressure of the system (PMO). Select the trap that will meet the capacity requirements at the differential pressure. Example:

Application: 2740 lbs/hr at 100 PSIG working pressure and 5 PSI differential pressure

Size/Model: 1 1/2" **FTT-145** (145 PSIG max), NPT connections

MATERIALS

Body & Cover	Ductile Iron
Gasket	Grafoil
Cover Screws	Steel, GR5
Float	Stainless Steel, AISI 304
Internals	Stainless Steel
Thermostat	Stainless Steel
Valve Seat	Stainless Steel, 17-4 PH
Valve Disc	Stainless Steel, AISI 420F

CAPACITIES – Condensate (lbs/hr)

Model	PMO (PSIG)	Pipe Size	Differential Pressure (PSI)																					
			1/4	1/2	1	2	5	10	15	20	30	40	50	65	75	100	125	145	200	225	250	300		
FTT-65	65	1/2", 3/4"	115	155	205	270	390	520	610	685	810	910	995	1110										
FTT-65	65	1"	340	500	775	1100	1700	2400	2800	3250	3925	4200	5000	5825										
FTT-65	65	1 1/2"	1150	1650	2500	3450	5300	7500	8180	10600	13100	15000	16800	18900										
FTT-65	65	2"	3470	4820	8500	11950	18700	25200	26900	36000	43000	49600	55500	61300										
FTT-145	145	1/2", 3/4"	55	75	100	135	200	270	320	365	435	490	540	600	640	725	795	850						
FTT-145	145	1"	190	275	405	550	840	1200	1380	1600	1850	2200	2450	2750	2920	3400	3700	3900						
FTT-145	145	1 1/2"	685	970	1275	1750	2740	3750	4490	5100	6250	7200	8000	8900	9600	11250	12000	13300						
FTT-145	145	2"	1860	2680	3125	4400	6900	9250	13790	14600	16900	19400	21900	25000	26800	31000	34000	37000						
FTT-225	225	1/2", 3/4"	40	50	70	95	135	185	220	245	290	330	360	405	430	485	530	565	645	680				
FTT-225	225	1"	150	200	300	405	600	820	975	1130	1375	1510	1620	1875	2000	2350	2600	2750	3100	3250				
FTT-250	250	1 1/2"	530	710	825	1130	1760	2500	2950	3375	4125	4740	5250	6000	6400	7300	8000	8650	10200	10800	11300			
FTT-250	250	2"	695	985	1560	2185	3490	4800	5800	6750	8250	9500	10650	12400	13300	15000	16600	18120	21200	22300	23200			
FTT-300	300	1"	100	155	220	300	460	630	750	860	1060	1240	1360	1450	1600	1820	2000	2130	2500	2650	2800	3000		

STEAM TRAPS

WFT Series

Float & Thermostatic Steam Trap

Watson McDaniel reserves the right to change the designs and/or materials of its products without notice.
©2010 Watson McDaniel Company

Model	WFT
Sizes	3/4", 1", 1 1/4", 1 1/2", 2"
Connections	NPT
Body Material	Cast Iron
PMO Max. Operating Pressure	250 PSIG
TMO Max. Operating Temperature	Saturated Steam Temperature
PMA Max. Allowable Pressure	250 PSIG up to 450°F
TMA Max. Allowable Temperature	450°F @ 250 PSIG



**WFT
3/4" & 1"**



**WFT
2"**



**WFT
1 1/4" & 1 1/2"**

TYPICAL APPLICATIONS

PROCESS: The **WFT Series** float and thermostatic steam traps are used for HVAC and industrial process applications. The excellent air handling capabilities of these traps make them a better choice than bucket traps for applications requiring quick start-up. Used on unit heaters, textile machines, heat exchangers, and other process equipment.

HOW IT WORKS

Float and thermostatic steam traps have a float and thermostatic element that work together to remove both condensate and air from the steam system. The valve, which is attached to a float, rises and opens the valve when condensate enters the trap. Air is discharged through the thermostatic air vent to the outlet side of the trap. The thermostatic air vent closes when steam enters the trap.

FEATURES

- All stainless steel internals with hardened seat and wear parts
- In-line repairability is simplified by having all internals attached to the cover
- Welded stainless steel thermostatic air vent resists shock from water hammer. Live orifice air vent is available for superheated applications
- Excellent air handling capability allowing air to be discharged rapidly and steam to enter the system quickly during start-up
- F & T traps discharge condensate immediately as it is formed (no condensate will back-up into the system)

SAMPLE SPECIFICATION

The trap shall be of float and thermostatic design with cast iron body and in-line piping configuration. Thermostatic air vent to be welded stainless steel. All internals must be stainless steel with hardened seat area. Trap must be in-line repairable.

INSTALLATION

Isolation valves should be installed with trap to facilitate maintenance. The trap must be level and upright for the float mechanism to operate. Trap must be sized and located properly in the steam system.

MAINTENANCE

Close isolation valves prior to performing any maintenance. All internal components can be replaced with the trap body remaining in-line. Repair kits include thermostatic air vent, float, valve seat and disc, and gaskets. For full maintenance details see Installation and Maintenance Manual.

OPTIONS

Live orifice air vent for superheated steam applications.

WFT Series

Float & Thermostatic Steam Trap

Dimensions: inches

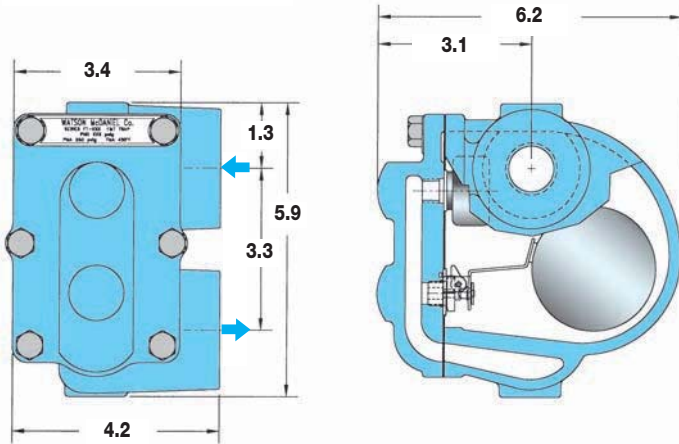

SPECIFICATIONS

Model	Sizes	Connection	PMO (PSIG)	PMA (PSIG)	Weight (lbs)
WFT-15	3/4", 1", 1 1/4"	NPT	15	125	9
WFT-30	3/4", 1", 1 1/4"	NPT	30	125	9
WFT-75	3/4", 1"	NPT	75	125	9
WFT-125	3/4", 1"	NPT	125	125	9

Dimensions: inches

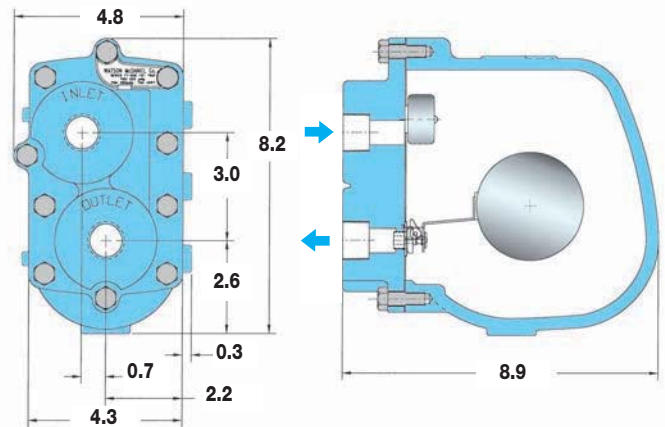

SPECIFICATIONS

Model	Sizes	Connection	PMO (PSIG)	PMA (PSIG)	Weight (lbs)
WFT-175	3/4", 1", 1 1/4"	NPT	175	250	20
WFT-250	3/4", 1", 1 1/4"	NPT	250	250	20

Dimensions: inches

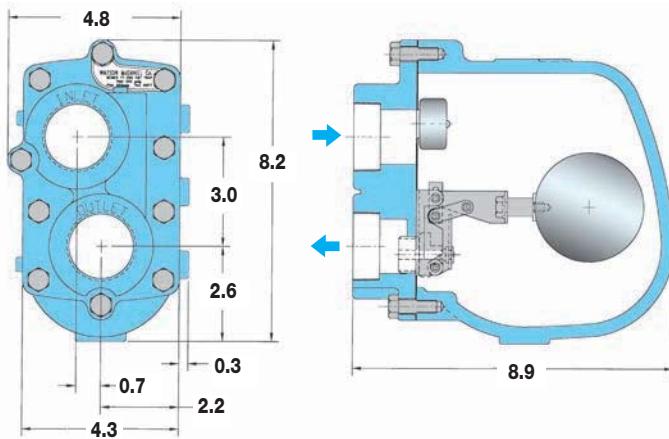

SPECIFICATIONS

Model	Sizes	Connection	PMO (PSIG)	PMA (PSIG)	Weight (lbs)
WFT-15	1 1/2"	NPT	15	250	21
WFT-30	1 1/2"	NPT	30	250	21
WFT-75	1 1/4", 1 1/2"	NPT	75	250	21
WFT-125	1 1/4", 1 1/2"	NPT	125	250	21
WFT-175	1 1/4", 1 1/2"	NPT	175	250	21
WFT-250	1 1/4", 1 1/2"	NPT	250	250	21

Dimensions: inches

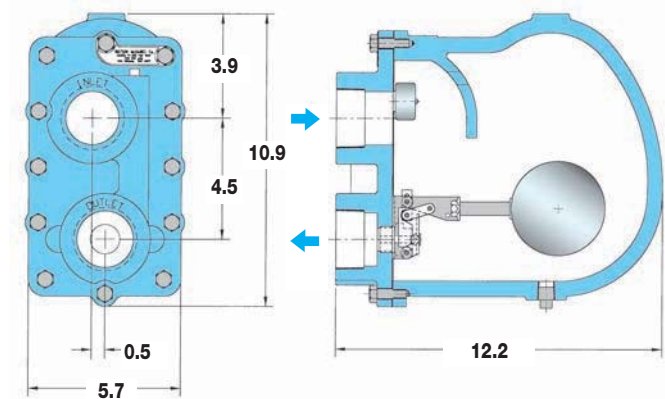

SPECIFICATIONS

Model	Sizes	Connection	PMO (PSIG)	PMA (PSIG)	Weight (lbs)
WFT-15	2"	NPT	15	250	53
WFT-30	2"	NPT	30	250	53
WFT-75	2"	NPT	75	250	53
WFT-125	2"	NPT	125	250	53
WFT-175	2"	NPT	175	250	53
WFT-250	2"	NPT	250	250	53

STEAM TRAPS

WFT Series

Float & Thermostatic Steam Trap

Watson McDaniel reserves the right to change the designs and/or materials of its products without notice.
©2010 Watson McDaniel Company

MATERIALS

Body & Cover	Cast Iron
Gasket	Grafoil
Cover Screws	Steel, GR5
Float	Stainless Steel, AISI 304
Internals	Stainless Steel, 300 Series
Thermostat	Stainless Steel
Valve Seat	Stainless Steel, 17-4 PH
Valve Disc	Stainless Steel, AISI 420F

HOW TO SIZE/ORDER

From the capacity chart, select the model that can handle the working pressure of the system (PMO). Select the trap that will meet the capacity requirements at the differential pressure. Example:

Application: 1,910 lbs/hr at 30 PSIG working pressure and 1/2 PSI differential pressure

Size/Model: 2" WFT-030-17, 0.500" Orifice, NPT connections

CAPACITIES – Condensate (lbs/hr)

Model	PMO (PSIG)	Pipe Size	Orifice Size	Differential Pressure (PSI)																		
				1/4	1/2	1	2	5	10	15	20	30	40	50	75	100	125	150	175	200	225	250
WFT-015-13	15	3/4"	0.250	390	490	620	780	1050	1320	1500												
WFT-015-14	15	1"	0.250	390	490	620	780	1050	1320	1500												
WFT-015-15	15	1 1/4"	0.312	610	770	960	1210	1630	2040	2330												
WFT-015-16	15	1 1/2"	0.500	1420	1910	2570	3460	5120	6890	8190												
WFT-015-17	15	2"	0.625	2260	2950	3860	5040	7170	9360	10930												
WFT-030-13	30	3/4"	0.228	330	420	530	670	930	1180	1350	1500	1720										
WFT-030-14	30	1"	0.228	330	420	530	670	930	1180	1350	1500	1720										
WFT-030-15	30	1 1/4"	0.228	330	420	530	670	930	1180	1350	1500	1720										
WFT-030-16	30	1 1/2"	0.390	930	1240	1650	2190	3210	4280	5060	5700	6750										
WFT-030-17	30	2"	0.500	1420	1910	2570	3460	5120	6890	8190	9260	11020										
WFT-075-13	75	3/4"	0.166	175	225	295	385	545	705	825	920	1075	1200	1305	1525							
WFT-075-14	75	1"	0.166	175	225	295	385	545	705	825	920	1075	1200	1305	1525							
WFT-075-15	75	1 1/4"	0.312	640	850	1130	1500	2180	2900	3420	3850	4540	5110	5600	6610							
WFT-075-16	75	1 1/2"	0.312	640	850	1130	1500	2180	2900	3420	3850	4540	5110	5600	6610							
WFT-075-17	75	2"	0.422	1020	1340	1760	2310	3330	4380	5140	5760	6770	7590	8290	9730							
WFT-125-13	125	3/4"	0.128	105	135	180	235	340	445	525	585	690	770	845	990	1110	1210					
WFT-125-14	125	1"	0.128	105	135	180	235	340	445	525	585	690	770	845	990	1110	1210					
WFT-125-15	125	1 1/4"	0.250	410	540	710	930	1340	1770	2070	2320	2730	3050	3340	3920	4390	4790					
WFT-125-16	125	1 1/2"	0.250	410	540	710	930	1340	1770	2070	2320	2730	3050	3340	3920	4390	4790					
WFT-125-17	125	2"	0.332	720	960	1270	1690	2460	3270	3860	4340	5130	5770	6320	7460	8390	9190					
WFT-175-13	175	3/4"	0.166	190	250	320	420	590	770	900	1010	1180	1310	1430	1670	1870	2030	2180	2310			
WFT-175-14	175	1"	0.166	190	250	320	420	590	770	900	1010	1180	1310	1430	1670	1870	2030	2180	2310			
WFT-175-15	175	1 1/4"	0.250	410	540	710	930	1340	1770	2070	2320	2730	3050	3340	3920	4390	4790	5150	5470			
WFT-175-16	175	1 1/2"	0.250	410	540	710	930	1340	1770	2070	2320	2730	3050	3340	3920	4390	4790	5150	5470			
WFT-175-17	175	2"	0.281	520	680	900	1180	1700	2230	2620	2930	3440	3860	4210	4950	5540	6050	6510	6920			
WFT-250-13	250	3/4"	0.128	115	145	190	245	345	450	520	580	675	755	820	955	1060	1155	1235	1310	1375	1440	1495
WFT-250-14	250	1"	0.128	115	145	190	245	345	450	520	580	675	755	820	955	1060	1155	1235	1310	1375	1440	1495
WFT-250-15	250	1 1/4"	0.203	270	350	450	590	820	1070	1240	1380	1600	1780	1940	2250	2500	2720	2910	3080	3240	3380	3520
WFT-250-16	250	1 1/2"	0.203	270	350	450	590	820	1070	1240	1380	1600	1780	1940	2250	2500	2720	2910	3080	3240	3380	3520
WFT-250-17	250	2"	0.250	410	540	710	930	1340	1760	2060	2310	2710	3040	3320	3890	4360	4760	5110	5430	5730	6000	6250

STEAM TRAPS

WSIB/WSIBH

Inverted Bucket Steam Trap

STEAM TRAPS

Units: inches

Model	WSIB, WSIBH
Size	1/2", 3/4"
Connections	NPT, SW
Body Material	Stainless Steel
PMO Max. Operating Pressure	450 PSIG*
TMO Max. Operating Temperature	750°F
PMA Max. Allowable Pressure	720 PSIG @ 100°F
TMA Max. Allowable Temperature	750°F @ 400 PSIG

*750°F @ operating pressures below 400 PSIG. See installation note regarding using trap in superheated applications.

TYPICAL APPLICATIONS

DRIP, TRACER: The WSIB inverted bucket trap is primarily used in drip and tracer applications. Inverted bucket traps can handle superheated steam when a check valve is used. These traps are also used on unit heaters, laundry equipment, and other small process equipment where slow start-up due to poor air handling capability can be tolerated.

HOW IT WORKS

When there is condensate in the system, the inverted bucket inside the steam trap sits on the bottom of the trap due to its inherent weight. This allows condensate to enter the trap and to be discharged through the seat orifice located at the top. When steam enters the trap, the bucket floats to the surface and closes off the discharge valve containing the steam in the system. Eventually steam is bled off through a small hole in the top of the bucket causing the bucket to sink which repeats the cycle.

FEATURES

- All stainless steel body
- Acceptable for superheated steam (with check valve installed at inlet)
- Water hammer resistant
- Valve & seat are at the top of the trap making it less sensitive to dirt
- All stainless steel internals with hardened valve & seat



WSIB
Inverted Bucket
Steam Trap

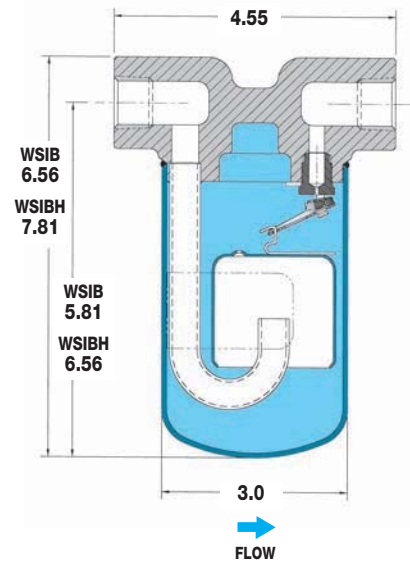

SAMPLE SPECIFICATION

Steam trap shall be an all stainless steel module design inverted bucket type with a frictionless valve lever assembly.

INSTALLATION & MAINTENANCE

Trap must be installed in upright position to function properly. Steam trap is non-repairable. If a new trap is required, remove and replace. With superheated steam, a check valve must be installed at inlet of trap. For full maintenance details, see Installation and Maintenance Manual.

MATERIALS

Body	Stainless Steel GR CF3
Cover	304L Stainless Steel
Internals	300 Series Stainless Steel
Valve Plug & Seat	420F Stainless Steel

CAPACITIES – Condensate (lbs/hr)

Model	Orifice Size	PMO (PSIG)	Differential Pressure (PSI)																					
			5	10	15	20	25	30	40	50	60	70	80	100	125	150	180	200	250	350	450			
WSIB-20	3/16"	20	450	560	640	690																		
WSIB-80	1/8"	80	300	350	400	440	460	500	550	580	635	660	690											
WSIB-150	#38	150	210	250	280	300	320	350	380	400	420	450	470	500	550	570								
WSIB-450	.057	450	31	50	70	84	95	105	120	133	145	152	160	174	187	198	208	215	228	248	263			
WSIBH-15	1/4"	15	830	950	1060																			
WSIBH-30	3/16"	30	530	700	820	880	950	1000																
WSIBH-70	5/32"	70	380	500	560	620	680	710	770	840	90	950												
WSIBH-125	1/8"	125	285	375	440	485	530	560	620	670	720	780	800	860	950									
WSIBH-200	7/64"	200	205	265	315	350	385	410	465	500	580	590	620	650	700	810	840	860						
WSIBH-250	#38	250	155	205	240	270	295	320	360	400	500	530	550	580	630	660	690	710	760					
WSIBH-450	.057	450	31	50	70	84	95	105	120	133	145	152	160	174	187	198	208	215	228	248	263			

STEAM TRAPS

IB Series

Inverted Bucket Steam Traps

Watson McDaniel reserves the right to change the designs and/or materials of its products without notice.
©2010 Watson McDaniel Company

Model	1031, 1032, 1033, 1034, 1031S, 1041, 1042, 1044, 1038S
Sizes	1/2", 3/4", 1", 1 1/4", 1 1/2"
Connections	NPT
Body Material	Cast Iron
Options	Internal check valve, air vent
PMO Max. Operating Pressure	250 PSIG
TMO Max. Operating Temperature	450°F
PMA Max. Allowable Pressure	250 PSIG up to 450°F
TMA Max. Allowable Temperature	450°F @ 250 PSIG

TYPICAL APPLICATIONS

DRIP, TRACER, PROCESS: The **IB Series** inverted bucket traps are available in several sizes and capacity ranges. Inverted bucket traps can handle superheated steam when a check valve is used. The smaller traps are primarily used in drip and tracer applications. These traps are also used on unit heaters, laundry equipment, and other process equipment where slow start-up due to poor air handling capability can be tolerated. Larger sizes are used on process equipment; however, since bucket traps have limited air handling capability, F&T traps are the preferred choice.

HOW IT WORKS

When there is condensate in the system, the inverted bucket inside the steam trap sits on the bottom of the trap due to its inherent weight. This allows condensate to enter the trap and to be discharged through the seat orifice located at the top. When steam enters the trap, the bucket floats to the surface and closes off the discharge valve containing the steam in the system. Eventually steam is bled off through a small hole in the top of the bucket causing the bucket to sink which repeats the cycle.

FEATURES

- Water hammer resistant
- Suitable for superheated steam (use internal check valve option to eliminate loss of prime)
- In-line repairability is simplified by having all internals attached to the cover
- Valve & seat are at the top of the trap making it less sensitive to dirt
- All stainless steel internals with hardened valve & seat

SAMPLE SPECIFICATION

The steam trap shall be of an inverted bucket trap design. Trap body and cover shall be of cast iron construction with all stainless steel internals and hardened seat and disc.

MAINTENANCE

All working components can be replaced with the trap body remaining in-line. The repair kit for the traps contain a lever and seat assembly with gasket. With superheated steam, a check valve must be installed at inlet of trap. For full maintenance details see Installation and Maintenance Manual.



1031/1032/1033/1034
(No Strainer)
1031S
(with Strainer)

1041/1042/1044/1038S
(with Strainer)

DIRECT REPLACEMENT FOR THE FOLLOWING ARMSTRONG MODELS

Watson Model	Armstrong Model
(Without Integral Strainer)	
1031	800
1032	811
1033	812
1034	813
(Includes Integral Strainer)	
1031S/1038S	N/A
1041	880
1042	881
1044	883

OPTIONS

Blowdown valve connection available on 1041, 1042, 1044 & 1038S. Thermic vent to improve air handling capability. Internal check valve for superheated or condensate backflow applications.

HOW TO SIZE/ORDER

From the capacity chart, select the model that can handle the working pressure of the system (PMO). Select the appropriate trap that will meet the capacity requirements at the differential pressure. Example:

Application: 1000 lbs/hr at 75 PSIG working pressure and 2 PSI differential pressure

Note: Specify Model, PMO and Connection Size

Size/Model: **IB-1034, 80 PSIG**, Specify pipe size (3/4", 1"), or **IB-1044, 80 PSIG**, Specify pipe size (3/4", 1")

STEAM TRAPS

IB Series

Inverted Bucket Steam Traps

Watson McDaniel reserves the right to change the designs and/or materials of its products without notice.
©2010 Watson McDaniel Company

MATERIALS

Body & Cover	Cast Iron, ASTM A-278 Class 30
Nuts & Bolts	High-Tensile Steel
Gasket	Non-Asbestos Fiber
Bucket	Stainless Steel
Lever & Seat Assembly	Stainless Steel
Valve & Seat	Hardened Stainless Steel
Integral Strainer*	Stainless Steel

* 1031S, 1038S, 1041, 1042, 1044 models only.

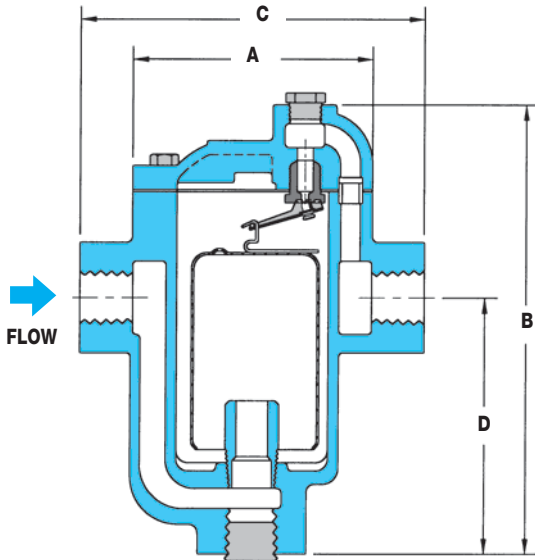

1031/1031S/1032/1033/1034
without Strainer (except 1031S)

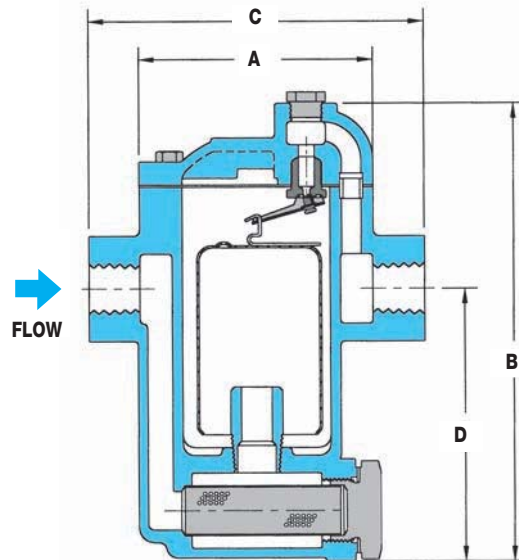

1041/1042/1044/1038S
with Strainer

DIMENSIONS & WEIGHTS – inches/pounds

Model	A	B	C	D	Weight (lbs)
1031	3.75	5.875	5.00	2.75	5
1031S*	3.75	5.875	5.00	2.75	5
1032	3.75	6.875	5.00	4.25	6
1033	5.625	9.06	6.50	5.375	15
1034	7.00	11.75	7.75	7.03	27
1041*	3.75	6.06	5.00	3.43	5
1042*	3.75	7.06	5.00	4.43	6
1044*	7.00	12.375	7.125	7.375	30
1038S*	7.00	12.375	7.125	7.375	30

* With Integral Strainer

IB Series

Inverted Bucket Steam Traps

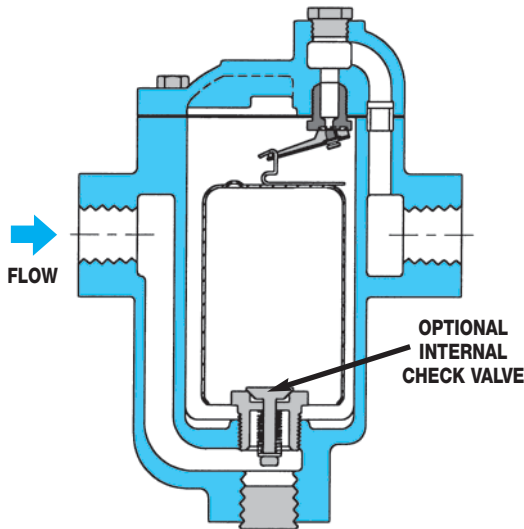

CHECK VALVE OPTION

The optional internal check valve allows the bucket trap to retain its prime even when exposed to superheated steam. Under vacuum conditions it will also stop condensate from back-flowing from the condensate return line into the steam system.

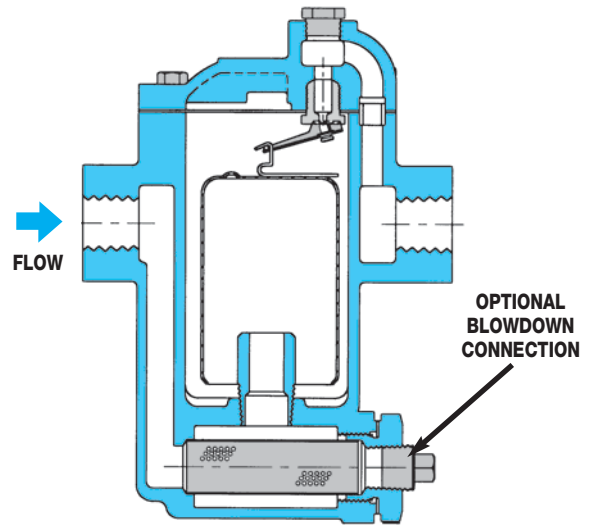

BLOWDOWN CONNECTION OPTION

A blowdown valve connection is available as an option on the **1041**, **1042**, **1044**, and **1038S** models. This simplifies maintenance by allowing the strainer to be cleaned without removal. User to supply blowdown valve.

REPLACEMENT KITS

A replacement kit containing the lever and seat assembly is a more economical option than replacing the entire steam trap. Also available are replacement screens, gaskets and buckets.

When ordering replacement lever and seat assemblies specify model and operating pressure. Reference price sheet for exact cross-reference to Armstrong PCA (Pressure Change Assembly) Kits.

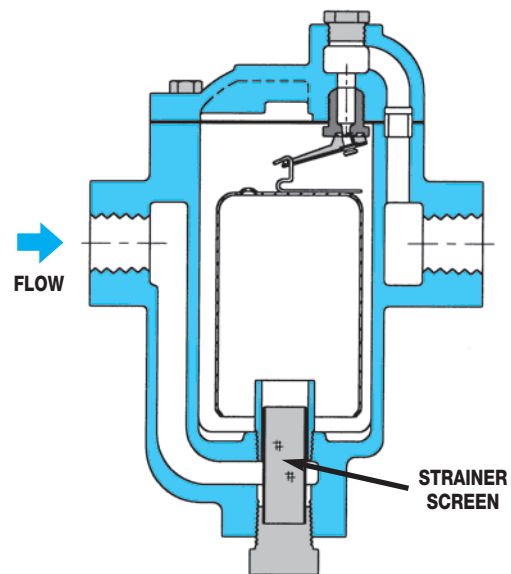

1031S

The **1031S** is equipped with a small protection screen to guard against dirt in the steam system. It is a more economical alternative than the 1041 which has a full-port strainer. Specifically designed for use in laundries. Available in 125 PSIG rating only.

QUICK-CHANGE TRAPS

Universal Style Steam Traps

(Universal Style Connectors and Universal Trap Modules)

Universal Style Steam Traps feature a permanent installation of the Universal Connector with a 2-bolt mounting arrangement for the Universal Steam Trap Module, allowing the Steam Trap to be removed and replaced in minutes

- ◆ without having to unthread piping
- ◆ by removing only 2-bolts with a socket or open-end wrench

7 different connectors • 6 different trap modules

Thermodynamic • Thermostatic • Inverted Bucket • Bi-Metallic • Float & Thermostatic

Any Universal Connector will work with any Universal Steam Trap Module

Model	WU450
Sizes	1/2", 3/4", 1"
Connections	NPT, SW, FLG
Body Material	Stainless Steel
PMO Max. Operating Pressure	(trap module dependent)
TMO Max. Operating Temperature	(trap module dependent)
PMA Max. Allowable Pressure	750 PSIG @ 100°F
TMA Max. Allowable Temperature	800°F @ 400 PSIG

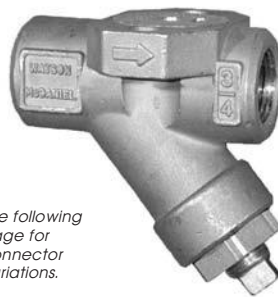

see following page for connector variations.

Universal Style Steam Traps are recommended in any application, – particularly those which require simple and frequent replacement of steam traps

Select a **Trap Module** for your application

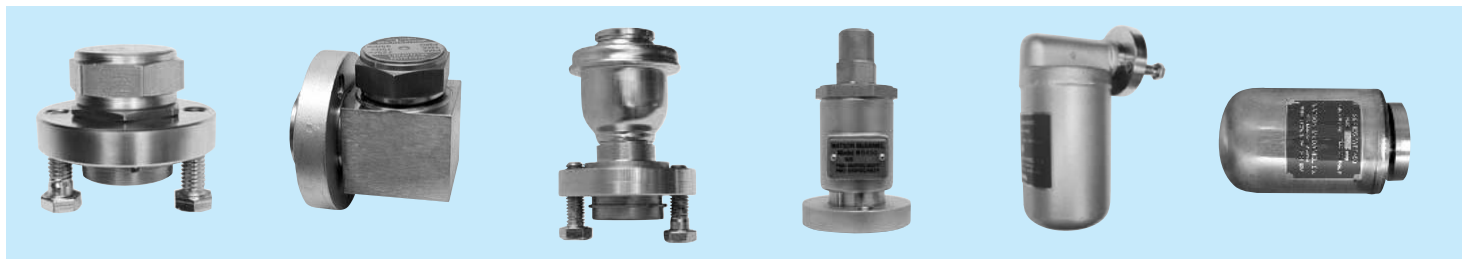

**WD450
WD450L**
Thermodynamic
"Top Mount"

**WD450SM
WD600LSM**
WD600LSM-HP
Thermodynamic
"Side Mount"

WT450
Thermostatic

WB450
Bi-Metallic

**WSIB450
WSIB450H**
Inverted Bucket

WFT450
Float & Thermostatic

QUICK-CHANGE TRAPS

Universal Style Steam Traps

(Universal Style Connectors and Universal Trap Modules)

It all adds up.... a Universal Style Connector + a Universal Trap Module = the most convenient, time-efficient & cost effective solution to maintaining your steam traps.

STEP 1: Select an appropriate Universal **STEAM TRAP MODULE** (shown below) for your application. Consult following pages for Steam Trap details.

STEP 2: Select appropriate Universal **CONNECTOR**. Any connector shown below will work with any Universal Steam Trap Module (including those of other manufacturers).

STEP 3: Order configured Universal Style Steam Traps.

UNIVERSAL TRAP MODULES



**WD450
WD450L
Thermodynamic
"Top Mount"**
Only recommended for Horizontal Piping Installations



**WD450SM
WD450LSM
WD600LSM-HP
Thermodynamic
"Side Mount"**



**WT450
Thermostatic**



**WB450
Bi-Metallic**



**WSIB450
WSIB450H
Inverted Bucket**



**WFT450
Float &
Thermostatic**

UNIVERSAL CONNECTORS



**WU450
No Strainer**



**WU450S
Strainer**



**WU450SB
Strainer &
Blowdown**



**WU450S-LR
Strainer**



**WU450SB-LR
Strainer &
Blowdown**



**WU450S-RL
Strainer**



**WU450SB-RL
Strainer &
Blowdown**

FEATURES

- 2-bolt mounting allows Trap Module to be removed and replaced without having to unthread piping
- Trap module can swivel 360° on the universal connector allowing proper orientation
- Compatible with other manufacturers trap modules
- All stainless steel construction
- Flange connections available for connector

Models WU450-LR (left to right flow as viewed) are Standard.

Models WU450-RL Connectors were made available for situations where problems occur due to obstructions or trap mounting orientation.

UNIVERSAL STYLE STEAM TRAPS

Universal Style Steam Traps

(Universal Style Connectors and Universal Trap Modules)

Universal Connectors are used in steam systems to simplify the replacement and maintenance of Steam Traps.

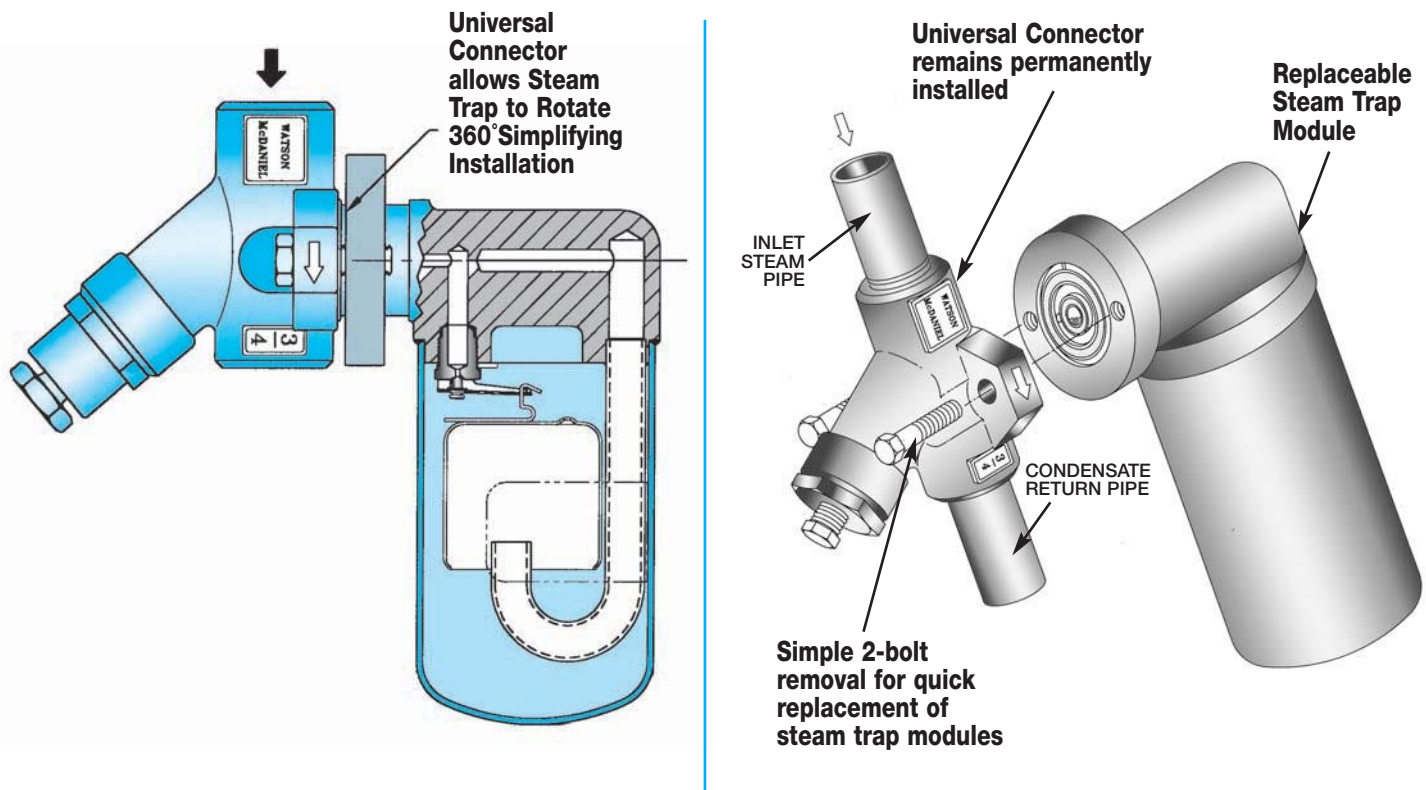

Universal Connectors allow Steam Traps to be removed and replaced in minutes without having to unthread piping.

Two bolts connect the steam trap module to the permanently-installed universal connector, allowing the trap module to be quickly and easily removed and replaced using an open-end or socket wrench. **Universal Style Steam Traps** are commonly used in chemical plants, petrochemical refineries, paper mills and most other industrial facilities. Watson McDaniel's WU450 connectors conform to industrial standards, making them compatible with other manufacturers' universal steam trap modules.

Watson McDaniel recommends using the Universal Style Steam Traps in any application, in particular those which require frequent maintenance or replacement of steam traps.

- Universal style steam traps with 2-bolt mounting allows for fast, easy replacement of trap module, making it more cost-effective than replacing conventional type steam traps
- All stainless steel construction
- Trap module can swivel 360° on the universal connector allowing any orientation during installation
- These universal connectors are compatible with most other manufacturer's trap modules
- Universal connectors are available with integral strainer and blowdown valve

UNIVERSAL STYLE STEAM TRAPS

WU450 Series

Universal Connectors for Universal Steam Trap Modules

Watson McDaniel reserves the right to change the designs and/or materials of its products without notice.
©2010 Watson McDaniel Company

Model	WU450, WU450S, WU450SB WU450S-LR, WU450SB-LR, WU450S-RL, WU450SB-RL
Sizes	1/2", 3/4", 1"
Connections	NPT, SW, FLG
Body Material	Stainless Steel
PMO Max. Operating Pressure	(trap module dependent)
TMO Max. Operating Temperature	(trap module dependent)
PMA Max. Allowable Pressure	750 PSIG @ 100°F
TMA Max. Allowable Temperature	800°F @ 400 PSIG

Steam Trap Modules that mount to Universal Connectors are shown on the following pages. Trap modules available in: Inverted Bucket, Float & Thermostatic, Thermodynamic, Thermostatic and Bi-metallic type.

TYPICAL APPLICATIONS

DRIP, TRACER: The **WU450 Series** Universal Connectors are used in steam systems where a simplified and economical maintenance program of steam traps is desired. These universal connectors can be used for drip service on steam mains and steam supply lines, tracing, or small process equipment. Industrial standard 2-bolt universal connectors are commonly used in chemical plants, petrochemical refineries, paper mills and other industrial facilities. The WU450 connectors conform to industrial standards, making them compatible with other manufacturers' universal steam trap modules.

Used with the following Watson McDaniel Steam Trap Modules:

- WSIB450** - Inverted Bucket
- WD450** - Thermodynamic
- WD450SM** - Thermodynamic
- WD600LSM** - Thermodynamic
- WT450** - Thermostatic
- WFT450** - Float & Thermostatic
- WB450** - Bi-Metallic

HOW IT WORKS

WU450 universal connectors remain permanently installed in the piping system. The convenient 2-bolt mounting system allows the trap module to be replaced quickly and easily using a socket or open-end wrench.

FEATURES

- Universal connector with 2-bolt mounting allows for fast, easy replacement of trap module making it more cost-effective than replacing conventional type steam traps
- All stainless steel construction
- Trap module can rotate 360° on the universal connector allowing any orientation during installation
- Compatible with most other manufacturers' trap modules
- Available with integral strainer and blowdown valve

SAMPLE SPECIFICATION

The Universal Connector shall be all stainless steel construction with a two-bolt 360 degree swivel mount flange design and available with integral strainer and blowdown valve.



WU450
no strainer



WU450S
with strainer

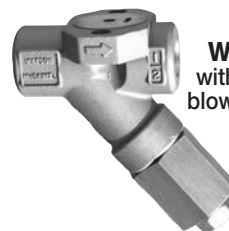

WU450SB
with strainer & blowdown valve



WU450S-LR
with strainer
(Flow direction
Left to Right)



WU450S-RL
with strainer
(Flow direction
Right to Left)



WU450SB-LR
with strainer & blowdown valve
(Flow direction
Left to Right)



WU450SB-RL
with strainer & blowdown valve
(Flow direction
Right to Left)

Note: Optional Flanged units available.

INSTALLATION

The universal connector can be installed in any position. Installation should include isolation valves.

MAINTENANCE

The strainer should be periodically cleaned by removal or use of the optional blowdown valve. For full maintenance details see Installation and Maintenance Manual.

MATERIALS

Body	Stainless Steel, AISI 316
Strainer	40 Mesh Stainless Steel, AISI 304
Blowdown Valve	Stainless Steel, AISI 303

HOW TO SIZE/ORDER

Specify universal connector. See following pages for Steam Trap Modules.

UNIVERSAL STYLE STEAM TRAPS

WU450 Series

Universal Connectors - Dimensions

Watson McDaniel reserves the right to change the designs and/or materials of its products without notice.
©2010 Watson McDaniel Company

WU450, WU450S, WU450SB, Universal Connectors
Connectors available in 1/2", 3/4" and 1" sizes in NPT or Socket-Weld Connections

Note: Optional Flange units available.

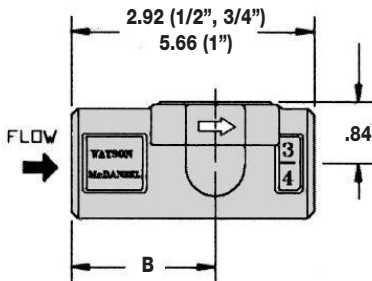

WU450
(No Strainer)

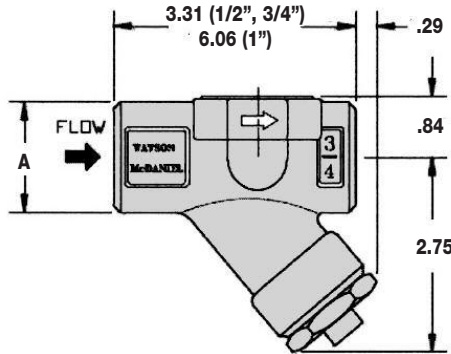

WU450S
(Strainer)

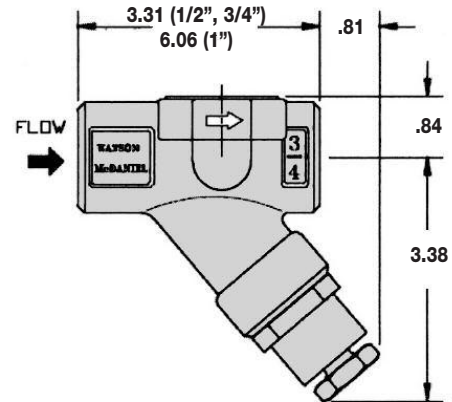

WU450SB
(Strainer & Blowdown)

DIMENSIONS - inches		
Size	A	B
1/2"	1.50	1.97
3/4"	1.50	1.97
1"	1.75	3.35

UNIVERSAL STYLE STEAM TRAPS

WU450 Series

Universal Connectors - Dimensions

WU450S-LR & WU450SB-LR Universal Connectors

Connectors available in 1/2", 3/4" and 1" sizes in NPT or Socket-Weld Connections

Note: Optional Flange units available.

Flow Direction - LEFT TO RIGHT

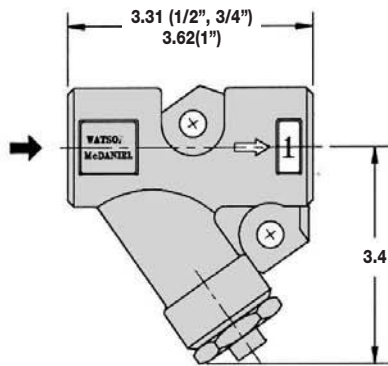

WU450S-LR
(Strainer)

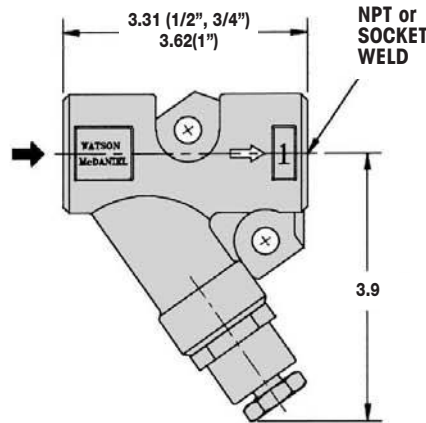

WU450SB-LR
(Strainer & Blowdown)

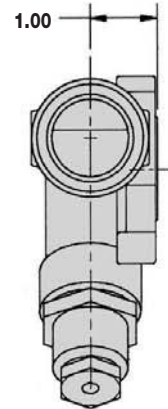

WU450S-RL & WU450SB-RL Universal Connectors

Connectors available in 1/2", 3/4" and 1" sizes in NPT or Socket-Weld Connections

Note: Optional Flange units available.

Flow Direction - RIGHT TO LEFT

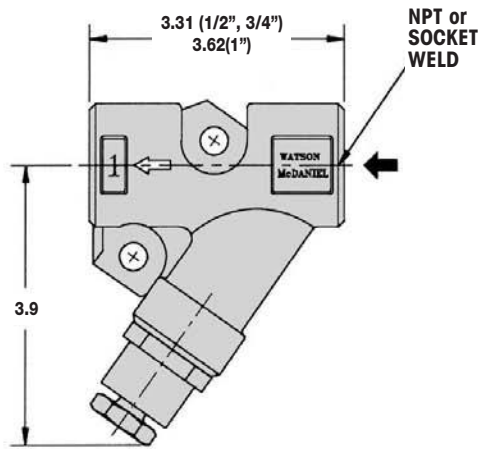
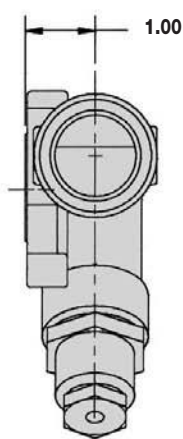

WU450SB-RL
(Strainer & Blowdown)

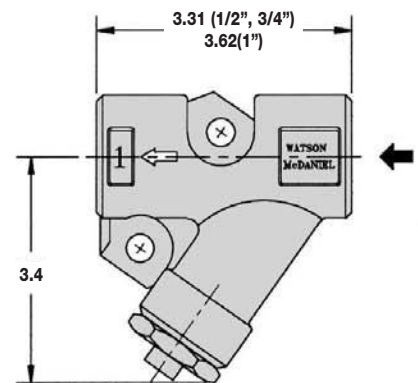

WU450S-RL
(Strainer)

UNIVERSAL STYLE STEAM TRAPS

WSIB450

Watson McDaniel reserves the right to change the designs and/or materials of its products without notice.
©2010 Watson McDaniel Company

Inverted Bucket **Steam Trap Module** (mounts to Universal Connectors)

Model	WSIB450, WSIB450H
Connections	Fits WU450 Series universal connectors
Body Material	Stainless Steel
PMO Max. Operating Pressure	450 PSIG*
TMO Max. Operating Temperature	800°F
PMA Max. Allowable Pressure	720 PSIG @ 100°F
TMA Max. Allowable Temperature	800°F @ 400 PSIG

*750°F @ operating pressures below 400 PSIG. See installation note regarding using trap in superheated applications.

Steam trap modules can be used with other manufacturers' Universal Connectors.



**WSIB450
Inverted Bucket
Steam Trap
Module**

TYPICAL APPLICATIONS

DRIP, TRACER: The **WSIB450** inverted bucket steam trap module, mounted to a universal connector, is typically used for drip and tracing applications. Also used on process equipment with light loads and where air removal is not critical. The WSIB450 trap module mounts to any universal connector.

HOW IT WORKS

The universal connector is permanently installed into the pipeline where the steam trap would normally be placed. The trap module is bolted to the universal connector with two bolts and sealed with a gasket. When a new trap module is needed, it can be easily removed and replaced with a standard open-end or socket wrench without disturbing the existing piping.

SAMPLE SPECIFICATION

The steam trap shall be an all stainless steel modular design, inverted bucket type with a frictionless valve lever assembly. The trap shall have a 360 degree swivel mount on a stainless steel Universal Connector that is available with integral strainer and blowdown valve options.

INSTALLATION & MAINTENANCE

Trap module must be installed in orientation shown. Installation should include isolation valves. With superheated steam, a check valve must be installed at inlet of trap. For full maintenance details, see Installation and Maintenance Manual.

OPTIONS

Universal Connectors are available with an integral strainer and blowdown valve. Connector is purchased separately. See the WU450 Universal Connectors section for more information.

FEATURES

- Trap module can be easily removed and replaced in minutes without having to disconnect any piping
- Hardened stainless steel valves and seat
- Freeze resistant
- Connectors available with integral strainers and blowdown valves
- 360° swivel design for convenient installation

MATERIALS

Body	Stainless Steel GR CF3
Cover	304L Stainless Steel
Internals	300 Series Stainless Steel
Valve Plug & Seat	420F Stainless Steel
Bolts	ASTM A193 GR B7
Gasket	Spiral-Wound 304 Stainless Steel with Grafoil Filler
Swivel Flange	303 Stainless Steel

CAPACITIES – Condensate (lbs/hr)

Model	Orifice Size	PMO (PSIG)	Differential Pressure (PSI)																																											
			5	10	15	20	25	30	40	50	60	70	80	100	125	150	180	200	250	350	450																									
WSIB450-20	3/16"	20	450	560	640	690																																								
WSIB450-80	1/8"	80	300	350	400	440	460	500	550	580	635	660	690																																	
WSIB450-150	#38	150	210	250	280	300	320	350	380	400	420	450	470	500	550	570																														
WSIB450-450	.057	450	31	50	70	84	95	105	120	133	145	152	160	174	187	198	208	215	228	248	263																									
WSIB450H-15	1/4"	15	830	950	1060																																									
WSIB450H-30	3/16"	30	530	700	820	880	950	1000																																						
WSIB450H-70	5/32"	70	380	500	560	620	680	710	770	840	900	950																																		
WSIB450H-125	1/8"	125	285	375	440	485	530	560	620	670	720	780	800	860	950																															
WSIB450H-200	7/64"	200	205	265	315	350	385	410	465	500	580	590	620	650	700	810	840	860																												
WSIB450H-250	#38	250	155	205	240	270	295	320	360	400	500	530	550	580	630	660	690	710	760																											
WSIB450H-450	.057	450	31	50	70	84	95	105	120	133	145	152	160	174	187	198	208	215	228	248	263																									

UNIVERSAL STYLE STEAM TRAPS

WFT450

Float & Thermostatic **Steam Trap Module** (mounts to Universal Connectors)

Model	WFT450
Connections	Fits WU450 Series universal connectors
Body Material	Stainless Steel
PMO Max. Operating Pressure	225 PSIG
TMO Max. Operating Temperature	397°F
PMA Max. Allowable Pressure	720 PSIG @ 100°F
TMA Max. Allowable Temperature	800°F @ 400 PSIG



WFT450
Float & Thermostatic
Steam Trap Module

Steam trap modules can be used with other manufacturers' Universal Connectors.

TYPICAL APPLICATIONS

PROCESS, DRIP: The **WFT450** Float & Thermostatic trap module mounted to a universal connector, is typically used on process equipment that generate light condensate loads and require excellent air handling capabilities. These low capacity float & thermostatic trap modules can also be used in drip service on steam mains, tracer systems and steam supply lines. The WFT450 trap module mounts to any universal connector.

HOW IT WORKS

The universal connector is permanently installed into the pipeline where the steam trap would normally be placed. The trap module is bolted to the universal connector with two bolts and sealed with a gasket. When a new trap module is needed, it can be easily removed and replaced with a standard open-end or socket wrench without disturbing the existing piping.

SAMPLE SPECIFICATION

The steam trap shall be an all stainless steel modular design, float & thermostatic unit. The thermostatic air vent to be pressure balanced welded bellows. The trap shall have a 360 degree swivel mount on a stainless steel Universal Connector that is available with integral strainer and blowdown valve options.

INSTALLATION & MAINTENANCE

Trap module must be installed in orientation shown. Installation should include isolation valves. For full maintenance details, see Installation and Maintenance Manual.

OPTIONS

Universal Connectors are available with an integral strainer and blowdown valve. Connector is purchased separately. See the Universal Connectors section for more information.

FEATURES

- Trap module can be easily removed and replaced in minutes without having to disconnect any piping
- Hardened stainless steel valves and seat
- Freeze resistant
- Connectors available with integral strainers and blowdown valves
- 360° swivel design for convenient installation

MATERIALS

Body	Stainless Steel GR CF3
Cover	304L Stainless Steel
Internals	300 Series Stainless Steel
Valve Disc	420F Stainless Steel
Valve Seat	17-4 PH Stainless Steel
Bolts	ASTM A193 GR B7
Gasket	Spiral-Wound 304 Stainless Steel with Grafoil Filler
Swivel Flange	303 Stainless Steel

CAPACITIES – Condensate (lbs/hr)

Model	PMO (PSIG)	Differential Pressure (PSI)																		
		1/4	1/2	1	2	5	10	15	20	30	40	50	65	75	100	125	145	200	225	
WFT450-15	15	390	490	620	780	1050	1320	1500												
WFT450-65	65	115	155	205	270	390	520	610	685	810	910	995	1110							
WFT450-145	145	55	75	100	135	200	270	320	365	435	490	540	600	640	725	795	850			
WFT450-225	225	40	50	70	95	135	185	220	245	290	330	360	405	430	485	530	565	645	680	

UNIVERSAL STYLE STEAM TRAPS

WD450 & WD450SM

Watson McDaniel reserves the right to change the designs and/or materials of its products without notice.
©2010 Watson McDaniel Company

Thermodynamic **Steam Trap Module** (mounts to Universal Connectors)

Model	WD450SM, WD450LSM (Side Mount Style) WD450, WD450L (Top Mount Style)
Connections	Fits WU450 Series Universal Connectors
Body Material	Stainless Steel
PMO Max. Operating Pressure	450 PSIG
TMO Max. Operating Temperature	750°F
PMA Max. Allowable Pressure	720 PSIG @ 100°F
TMA Max. Allowable Temperature	800°F @ 400 PSIG



WD450SM
Thermodynamic Steam Trap Module
(Side Mount Style)
For vertical or horizontal piping installations.



WD450
Thermodynamic Steam Trap Module
(Top Mount Style)
Recommended for horizontal piping installations only so that cap can be oriented upwards as shown.

Steam trap modules can be used with other manufacturers' Universal Connectors.

TYPICAL APPLICATIONS

DRIP, TRACER: The **WD450SM & WD450** steam trap modules mounted to a universal connector can be used anywhere conventional thermodynamic steam traps are used. Used on drip, tracing and light process applications where removal of air is not critical. The WD450 & WD450SM trap modules mount to any Universal Connector. The WD450 is recommended for horizontal piping only so that cap can be oriented upwards, as shown.

HOW IT WORKS

The universal connector is permanently installed into the pipeline where the steam trap would normally be placed. The trap module is bolted to the universal connector with two bolts and sealed with two gaskets. When a new trap module is needed, it can be easily removed and replaced with a standard open-end or socket wrench without disturbing the existing piping.

FEATURES

- Trap module can be easily removed and replaced in minutes without having to disconnect any piping
- Trap modules can be used with most manufacturers' 2-bolt universal connector
- All stainless steel construction with hardened seat

SAMPLE SPECIFICATION

The steam trap module shall be designed to attach to the industry standard two-bolt universal connector. Trap module shall be of a thermodynamic design. Universal connector shall conform to the two bolt industry standard with integral strainer and blowdown options.

INSTALLATION

Trap module must be installed in orientation shown. Isolation valves should be installed before and after the universal connector to facilitate maintenance. Trap module is attached to the connector using two bolts and two sealing gaskets.

MAINTENANCE

If the trap fails for any reason, replace only the trap module. If universal connector is equipped with an integral strainer it should be cleaned periodically. For full maintenance details see Installation and Maintenance Manual.

OPTIONS

Universal Connectors are available with an integral strainer and blowdown valve. Connector is purchased separately. See the Universal Connectors section for more information.

MATERIALS

Body	Stainless Steel, AISI 420
Disc	Stainless Steel, AISI 420
Cap	Stainless Steel, AISI 416
Insulation Cover	Stainless Steel, AISI 304
Bolts	Steel, ASTM A193 GR B7
Gaskets (2)	Spiral Wound 304 Stainless Steel with Grafoil Filler

CAPACITIES – Condensate (lbs/hr)

Model	Differential Pressure (PSI)																
	4	10	15	20	25	30	40	50	75	100	150	200	250	300	350	400	450
WD450L WD450LSM	140	215	242	270	295	320	355	390	455	510	600	670	730	790	840	880	925
WD450 WD450SM	247	370	420	475	520	560	625	685	800	900	1060	1185	1300	1400	1485	1560	1630

UNIVERSAL STYLE STEAM TRAPS

WD600LSM-HP

High-Pressure Thermodynamic **Steam Trap Module** (mounts to Universal Connectors)

Model	WD600LSM-HP (Side Mount Style)
Connections	Fits WU450 Series Universal Connectors
Body Material	Stainless Steel
PMO Max. Operating Pressure	600 PSIG
TMO Max. Operating Temperature	750°F
PMA Max. Allowable Pressure	720 PSIG @ 100°F
TMA Max. Allowable Temperature	800°F @ 600 PSIG



WD600LSM-HP
HIGH PRESSURE
Thermodynamic
Steam Trap Module
(Side Mount Style)

Units: Inches

Steam trap modules can be used with other manufacturers' Universal Connectors.

TYPICAL APPLICATIONS

DRIP, TRACER: The **WD600LSM-HP** steam trap module mounted to a universal connector can be used anywhere conventional thermodynamic steam traps are used. Used on drip, tracing and light process applications where removal of air is not critical. The **WD600LSM-HP** trap module mounts to any Universal Connector.

HOW IT WORKS

The universal connector is permanently installed into the pipeline where the steam trap would normally be placed. The trap module is bolted to the universal connector with two bolts and sealed with two gaskets. When a new trap module is needed, it can be easily removed and replaced with a standard open-end or socket wrench without disturbing the existing piping.

FEATURES

- Trap module can be easily removed and replaced in minutes without having to disconnect any piping
- Trap modules can be used with most manufacturers' 2-bolt universal connector
- All stainless steel construction with hardened seat

SAMPLE SPECIFICATION

The steam trap module shall be designed to attach to the industry standard two-bolt universal connector. Trap module shall be of a thermodynamic design. Universal connector shall conform to the two bolt industry standard with integral strainer and blowdown options.

Model	CAPACITIES – Condensate (lbs/hr)					
	Differential Pressure (PSI)					
	150	200	250	300	450	600
WD600LSM-HP	465	500	550	600	675	730

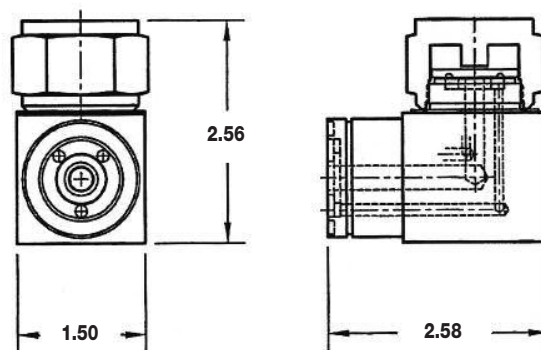

WD600LSM-HP Thermodynamic
Steam Trap Module

INSTALLATION

Isolation valves should be installed before and after the universal connector to facilitate maintenance. Trap module is attached to the connector using two bolts and two sealing gaskets.

MAINTENANCE

If the trap fails for any reason, replace only the trap module. If universal connector is equipped with an integral strainer it should be cleaned periodically. For full maintenance details see Installation and Maintenance Manual.

OPTIONS

Universal Connectors are available with an integral strainer and blowdown valve. Connector is purchased separately. See the Universal Connectors section for more information.

MATERIALS

Body	Stainless Steel, AISI 420
Disc	Stainless Steel, AISI 420
Cap	Stainless Steel, AISI 416
Insulation Cover	Stainless Steel, AISI 304
Bolts	Steel, ASTM A193 GR B7
Gaskets (2)	Spiral Wound 304 Stainless Steel with Grafoil Filler

UNIVERSAL STYLE STEAM TRAPS

WT450

Watson McDaniel reserves the right to change the designs and/or materials of its products without notice.
©2010 Watson McDaniel Company

Thermostatic **Steam Trap Module** (mounts to Universal Connectors)

Model	WT450
Connections	Fits WU450 Series Universal Connectors
Body Material	Stainless Steel
PMO Max. Operating Pressure	450 PSIG
TMO Max. Operating Temperature	Saturated Steam Temp.
PMA Max. Allowable Pressure	720 PSIG @ 100°F
TMA Max. Allowable Temperature	800°F @ 400 PSIG

Steam trap modules can be used with other manufacturers' Universal Connectors.



**WT450
Thermostatic
Steam Trap
Module**

TYPICAL APPLICATIONS

DRIP, TRACER, PROCESS: The WT450 steam trap module mounted on a universal connector can be used anywhere conventional thermostatic steam traps are used. Used on drip, tracing and light process applications. The WT450 trap module mounts to any universal connector.

HOW IT WORKS

The universal connector is permanently installed into the pipeline where the steam trap would normally be placed. The trap module is bolted to the universal connector with two bolts and sealed with two gaskets. When a new trap module is needed, it can be easily removed and replaced with a standard open-end or socket wrench without disturbing the existing piping.

FEATURES

- Trap module can be easily removed and replaced in minutes without having to disconnect any piping
- Trap modules can be used with most manufacturers' 2-bolt universal connector
- All stainless steel construction with hardened seat

SAMPLE SPECIFICATION

The steam trap module shall be designed to attach to the industry standard two-bolt universal connector. Trap module shall be of a thermostatic design. The universal connector shall conform to the two-bolt industry standard with integral strainer and blowdown options.

INSTALLATION

Isolation valves should be installed before and after the universal connector to facilitate maintenance. Trap module is attached to the connector using two bolts and two sealing gaskets.

MAINTENANCE

When a new trap module is needed, it can be easily removed and replaced with a standard open-end wrench without disturbing the existing piping. If the universal connector is equipped with an integral strainer it should be cleaned periodically. For full maintenance details see Installation and Maintenance Manual.

OPTIONS

Universal Connectors are available with an integral strainer and blowdown valve. Connector is purchased separately. See the Universal Connectors section for more information.

MATERIALS

Body	Stainless Steel, AISI 420
Thermal Element	Stainless Steel, AISI 302
Disc & Seat	Stainless Steel, AISI 420
Insulation Cover	Stainless Steel, AISI 304
Bolts	Steel, ASTM A193 GR B7
Gaskets (2)	Spiral Wound 304 Stainless Steel with Grafoil Filler

CAPACITIES – Condensate (lbs/hr)

Model	Orifice Size	Steam Inlet Pressure (PSIG)												
		5	10	20	50	100	125	150	200	250	300	350	400	450
WT450	3/16"	441	625	882	1391	1827	1969	2095	2305	2483	2636	2777	2903	3019

Note: 5/64" low capacity orifice is available upon request.

Back Pressure as Percentage of Inlet Pressure	10	20	25	30	40	50	60	70	80	90
Percent Decrease in Trap Capacity	0	0	0	2	5	12	20	30	40	55

UNIVERSAL STYLE STEAM TRAPS

WB450

Bi-Metallic Steam Trap Module (mounts to Universal Connectors)

Model	WB450
Connections	Fits WU450 Series Universal Connectors
Body Material	Stainless Steel
PMO Max. Operating Pressure	450 PSIG
TMO Max. Operating Temperature	662°F
PMA Max. Allowable Pressure	720 PSIG @ 100°F
TMA Max. Allowable Temperature	800°F @ 400 PSIG

Steam trap modules can be used with other manufacturers' Universal Connectors.



**WB450
Bi-Metallic
Steam Trap
Module**

TYPICAL APPLICATIONS

The **WB450** Series Bi-Metallic Module is used in steam tracing applications (process lines, instrumentation and winterization, general steam jacketing) and small process applications where accurate control of condensate discharge temperature is required to provide maximum usage of energy.

HOW IT WORKS

Bi-Metallic plates of dissimilar metals respond to steam temperature variations, whereby the metals are relaxed at relatively cool conditions, such as start-up, and the trap is open for the discharge of condensate. As temperature nears the preset subcool temperature below saturation, the metals react and expand, closing the trap and preventing the loss of live steam. Field adjustability of the bimetal element allows precise control of the condensate discharge temperature.

FEATURES

- Excellent for various steam tracing and small process applications where maximum energy usage is desired
- Field-adjustable bimetal element allows precise control of condensate discharge temperature, providing maximum use of additional energy in the condensate
- Internal screen and seat/plug design help prevent pipe scale and debris from accumulating on seating surfaces to provide trouble-free operation

MATERIALS

Body and Cover	Stainless Steel, A-351, Gr. CF8
Bimetal Element	GB14
Valve Seat	420 Stainless Steel
Gaskets (2)	Spiral Wound 304 Stainless Steel with Grafoil Filler
Valve Stem	Stainless Steel with Grafoil Filler

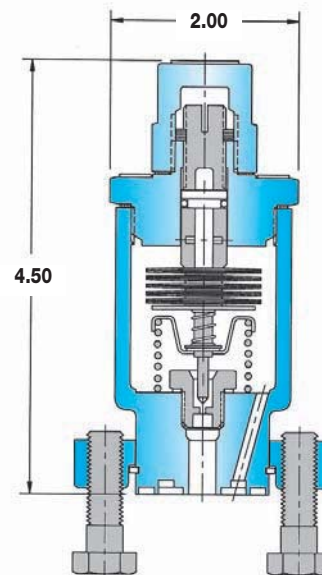

Units: Inches

Maximum Trap Capacities at Various Inlet Pressures and Set Temperatures – Condensate (lbs/hr)

Set Temperature	Steam Inlet Pressure (PSIG)											
	15	30	50	100	125	150	200	250	300	350	400	450
220°F	56	70	102	144	161	177	204	228	250	270	289	306
240°F	116	164	212	300	336	368	425	475	520	562	600	637
260°F	134	190	245	346	387	424	490	548	600	648	693	735
280°F	143	202	261	370	413	453	523	584	640	691	739	784

- Notes:**
- 1) Capacities in chart are based on discharging condensate to atmosphere with a condensate temperature of 200° F.
 - 2) Maximum discharge capacity up to 970 lbs/hr, depending on operating condition requirements.
 - 3) Contact factory for additional information including other condensate set and discharge temperatures.
 - 4) To ensure proper operation and eliminate possible steam loss, the Set Temperature should be lower than 27 °F subcool (degrees below inlet steam saturation temperature).

UNIVERSAL STYLE STEAM TRAPS

450 Series

Watson McDaniel reserves the right to change the designs and/or materials of its products without notice.
©2010 Watson McDaniel Company

WT450 & WD450 Steam Traps with Universal Connectors - Dimensions

WT450 Trap Module with Universal Connectors

Connectors available in 1/2", 3/4" and 1" sizes in NPT and Socket-Weld Connections

Note: Optional Flange units available.

Units: inches

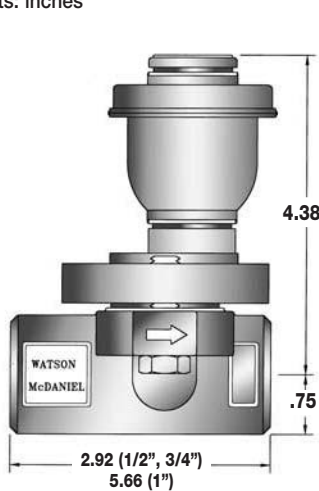

WT450 Trap Module with WU450 Connector

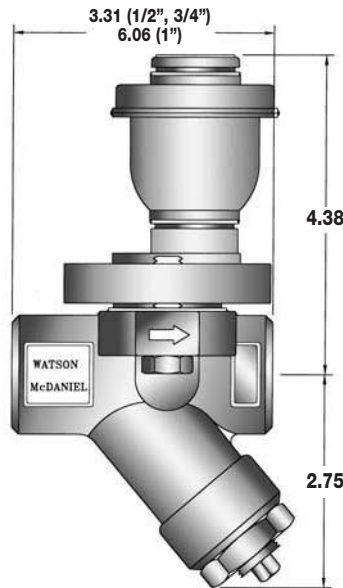

WT450 Trap Module with WU450S Connector (Strainer)

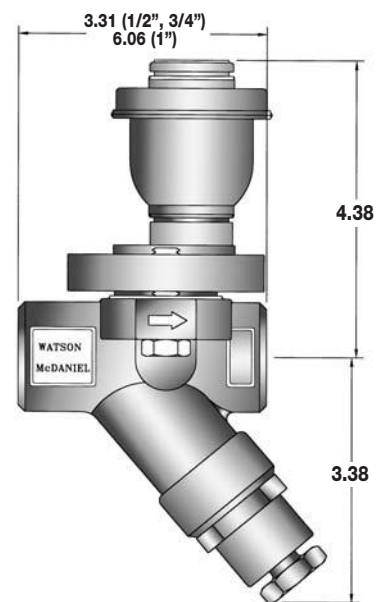

WT450 Trap Module with WU450SB Connector (Strainer & Blowdown)

WD450 Trap Module with Universal Connectors

Connectors available in 1/2", 3/4" and 1" sizes in NPT and Socket-Weld Connections

Note: Optional Flange units available.

Units: inches

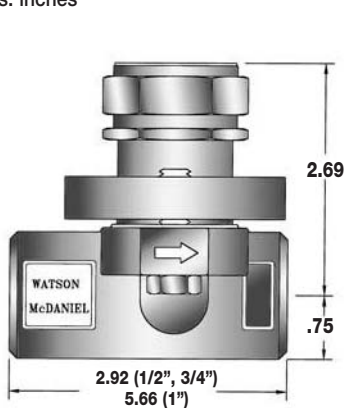

WD450 Trap Module with WU450 Connector

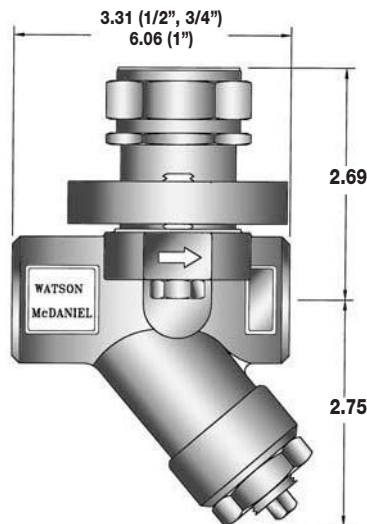

WD450 Trap Module with WU450S Connector (Strainer)

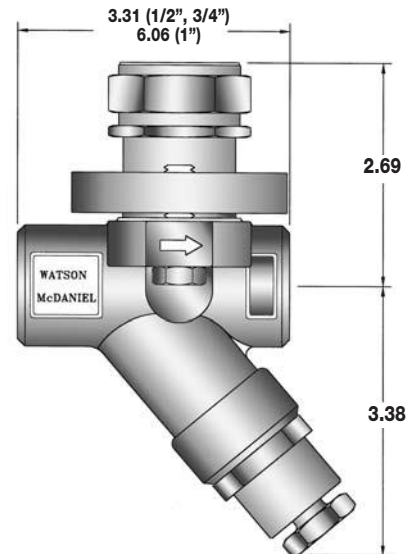

WD450 Trap Module with WU450SB Connector (Strainer & Blowdown)

450 Series

WSIB450 Steam Traps with Universal Connectors - Dimensions

WSIB450 Trap Module with Universal Connectors
 Connectors available in 1/2", 3/4" and 1" sizes in NPT or Socket-Weld Connections

Note: Optional Flange units available.

Units: inches

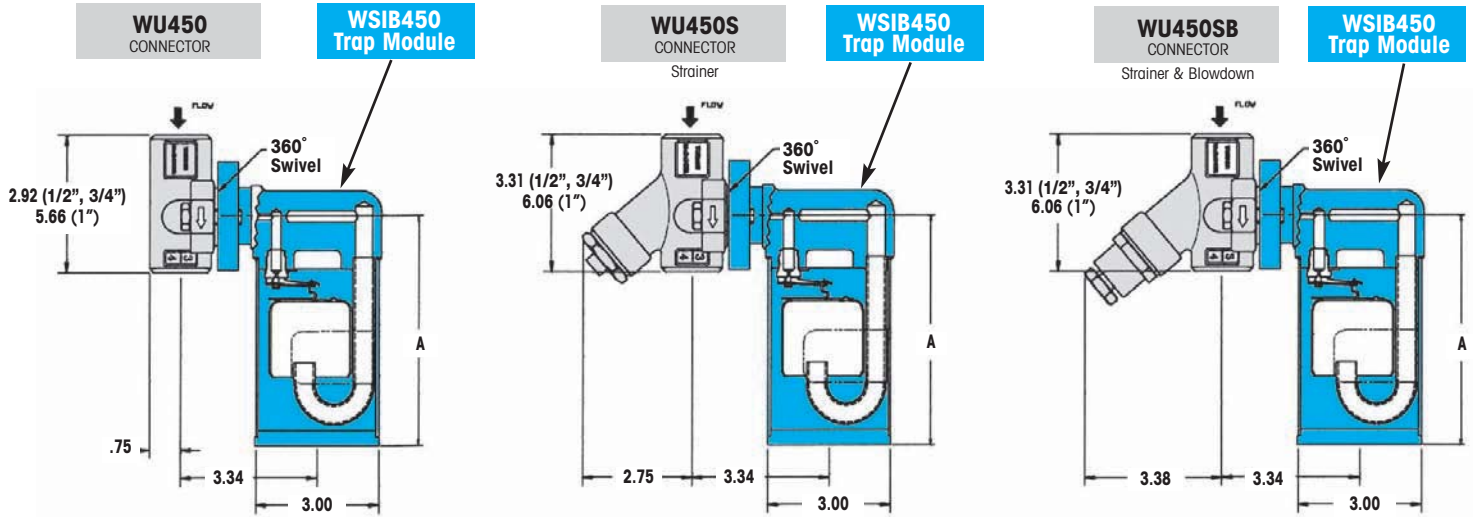

WSIB450 A-Dimension = 5.81"
WSIB450H A-Dimension = 6.81"

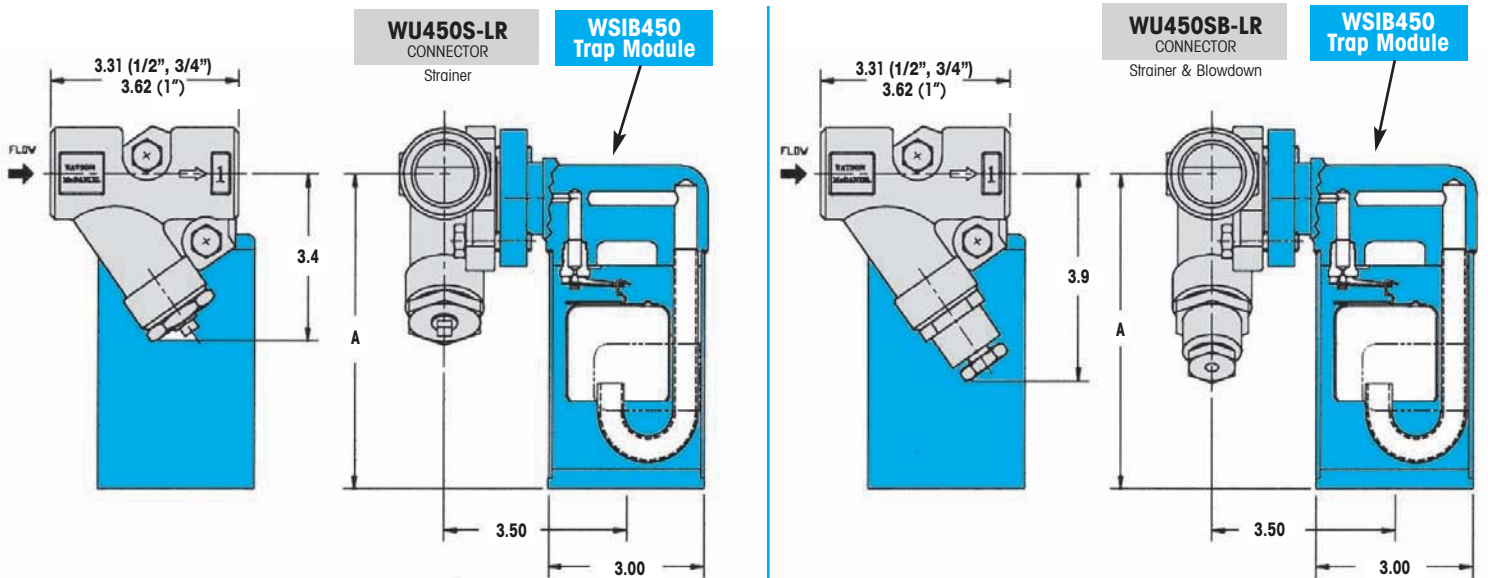

WSIB450 A-Dimension = 6.12"
WSIB450H A-Dimension = 7.12"

UNIVERSAL STYLE STEAM TRAPS

450 Series

WFT450 Steam Trap Modules with Universal Connectors - Dimensions

Watson McDaniel reserves the right to change the designs and/or materials of its products without notice.
©2010 Watson McDaniel Company

WFT450 Trap Module with Universal Connectors

Connectors available in 1/2", 3/4" and 1" sizes in NPT or Socket-Weld Connections

Note: Optional Flange units available.

Units: inches

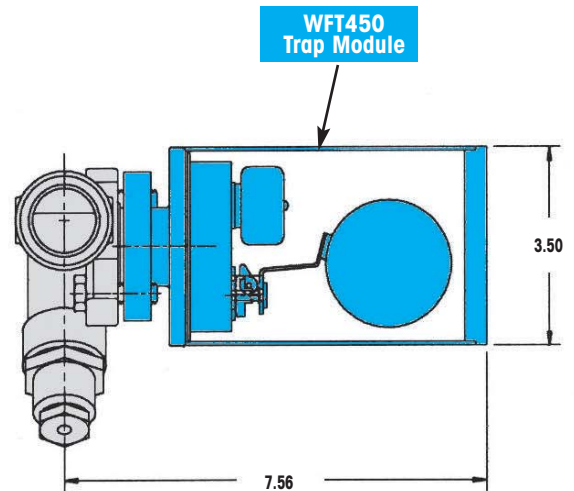
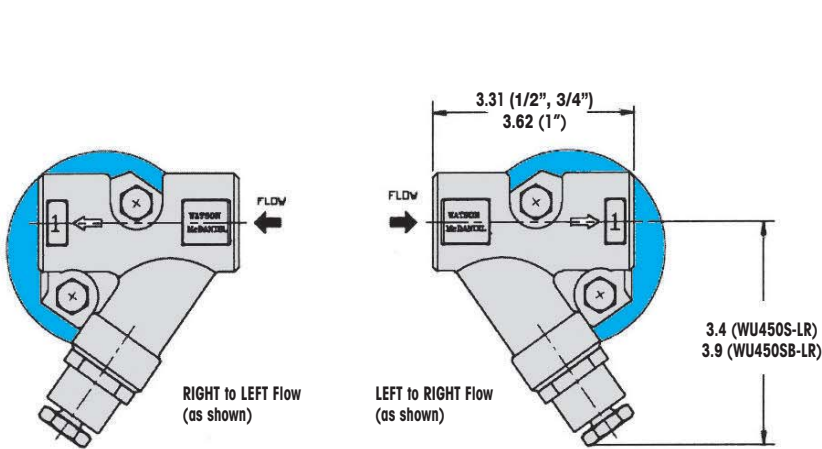
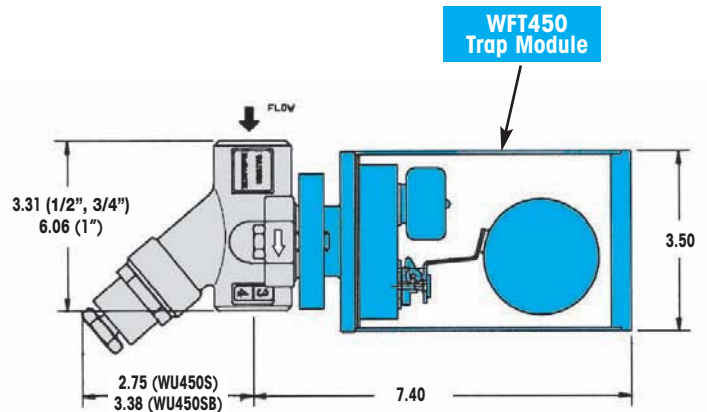
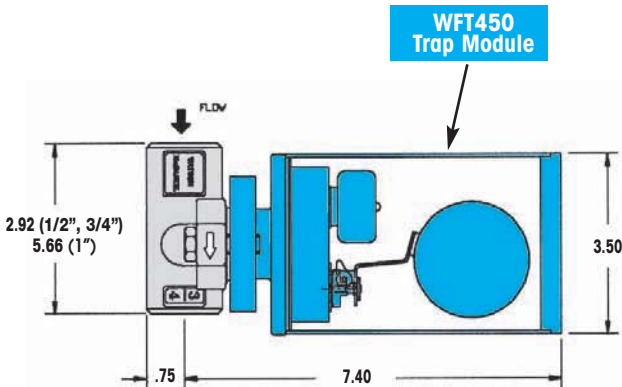

450 Series

WD450SM/
WB450 & WD600LSM-HP Steam Trap Modules with Universal Connectors - Dimensions

WB450 Trap Module with Universal Connectors

Connectors available in 1/2", 3/4" and 1" sizes in NPT and Socket-Weld Connections

Note: Optional Flange units available.

Units: inches

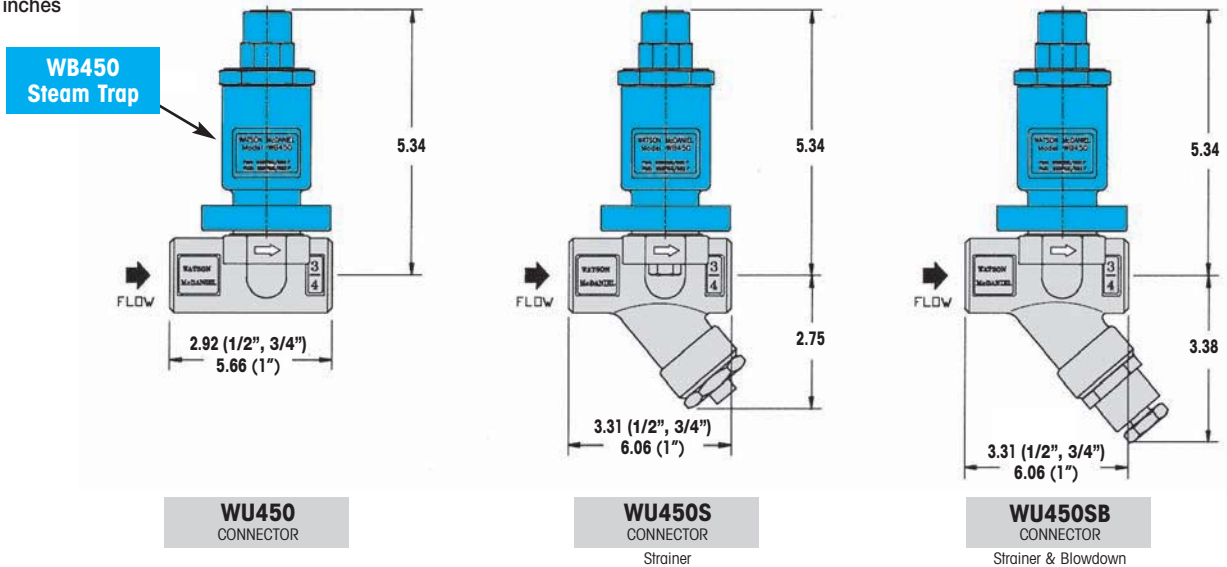

WD450SM & WD600LSM-HP Trap Module with Universal Connectors

Connectors available in 1/2", 3/4" and 1" sizes in NPT and Socket-Weld Connections

Note: Optional Flange units available.

Units: inches

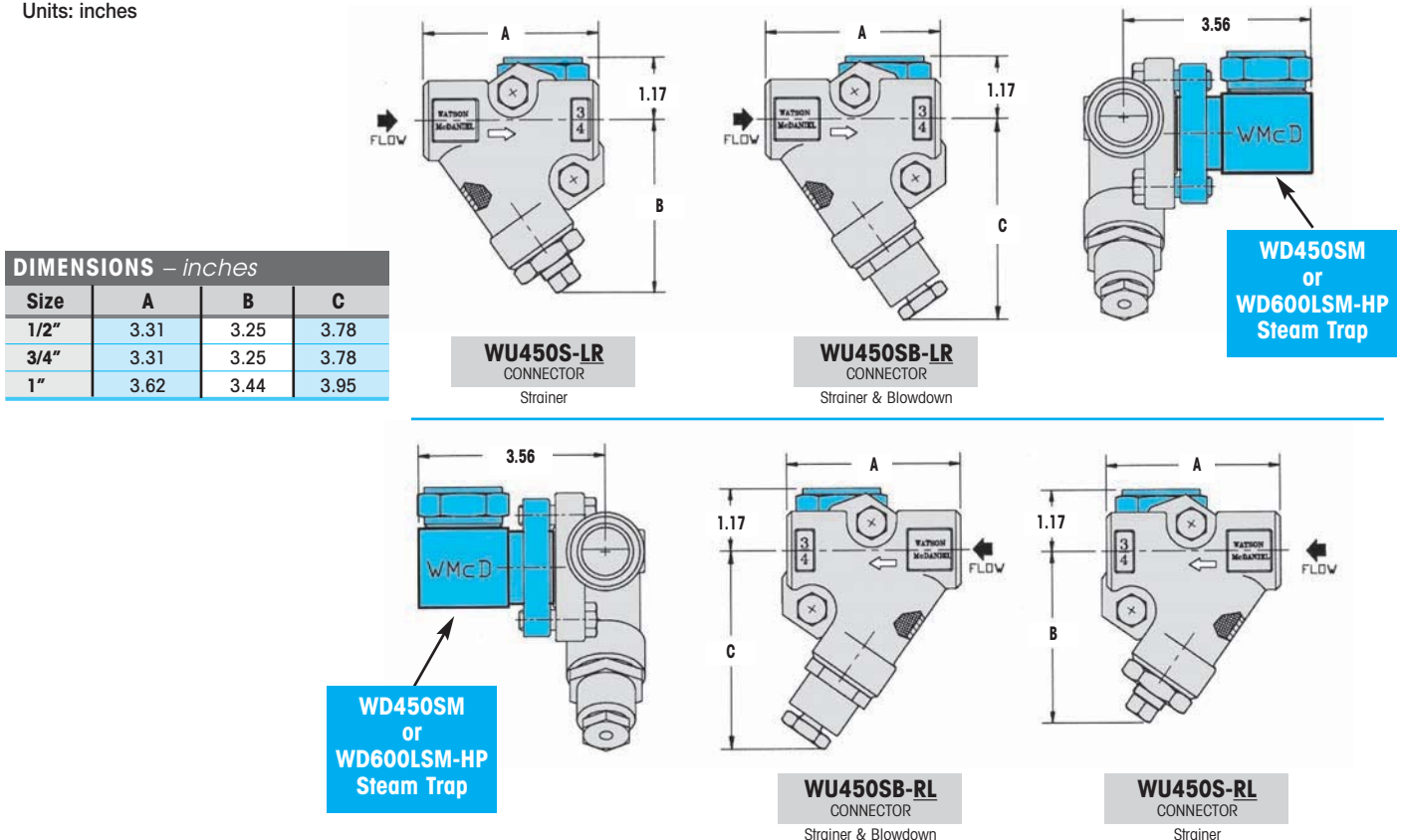

STEAM TRAPS

FDA400 Series

Thermostatic Clean Steam Trap (Repairable)

Watson McDaniel reserves the right to change the designs and/or materials of its products without notice.
©2010 Watson McDaniel Company

Model	FDA401, FDA402, FDA403
Sizes	1/2", 3/4"
Connections	Tri-clamp
Body Material	Stainless Steel
PMO Max. Operating Pressure	90 PSIG
TMO Max. Operating Temperature	Saturated Steam Temperature
PMA Max. Allowable Pressure	145 PSIG up to 338°F
TMA Max. Allowable Temperature	350°F @ 132 PSIG



FDA402
shown



Sanitary
Clamp for
Trap Body

TYPICAL APPLICATIONS

DRIP, PROCESS: The **FDA400 Series** thermostatic steam traps are used on clean steam applications as drip traps on piping runs as well as drainage for CIP/SIP systems and various process vessels. The FDA400 Series allows for a 90° connection on either the inlet or outlet capable of 360° orientation.

HOW IT WORKS

The thermostatic trap contains a welded 316L stainless steel thermal element that expands when heated and contracts when cooled. When air and condensate are present the trap is in the open discharge position. When steam reaches the trap the element expands closing the trap tightly.

FEATURES

- Universal horizontal connection swivels to any angle
- All wetted parts are 316L stainless steel
- Electro-polish finish of **20-25** microinches RA on **internal** body
- Electro-polish finish of **25-32** microinches RA on **external** body
- Operates close to saturation curve to minimize condensate back-up
- Completely self-draining in the vertical downward flow orientation

MATERIALS

Body	Stainless Steel, AISI 316L
Gasket	Teflon Coated Elastomer
Element Plate	Stainless Steel, AISI 316L
Thermal Element	Stainless Steel, AISI 316L
Clamp	Stainless Steel, AISI 304

CAPACITIES – Condensate (lbs/hr)

Orifice Size (Inches)	Differential Pressure (PSI)					
	5	10	20	50	75	90
9/64	140	240	400	690	850	950
5/16	850	1200	1695	2690	3165	3400

Note: Capacities at 10°F below saturation.

SAMPLE SPECIFICATION

The Steam Trap shall be all 316L stainless steel thermostatic type with a balanced pressure bellows that operates close to saturated steam temperatures. Inlet, outlet or both connections must contain a 90° swivel arrangement capable of 360° orientation. Internal body parts shall have an electro-polish finish of 20-25 microinches RA internally and a 25-32 finish externally. The unit shall have a split-body sanitary clamp design for easy maintenance. Trap shall be completely self-draining when mounted vertically.

INSTALLATION & MAINTENANCE

Trap is designed for installation in a vertical, downward flow orientation to ensure that the self-draining clean steam requirement is satisfied. For full maintenance details see Installation and Maintenance Manual.

FDA400 Series Connections: 1/2" & 3/4"

Units: inches

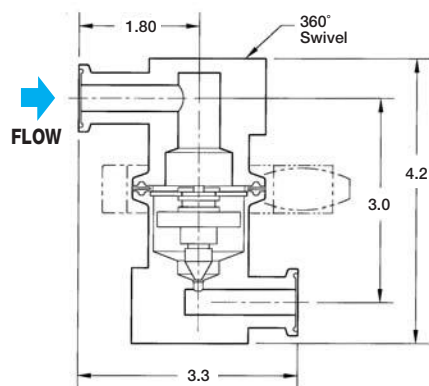

FDA401 Inlet: 90° Angle
Outlet: 90° Angle

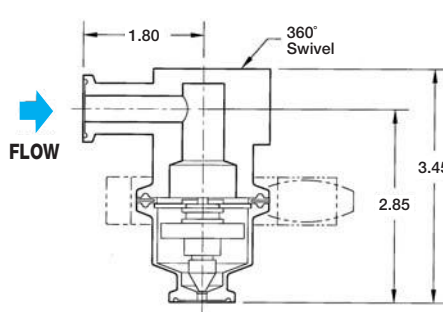

FDA402 Inlet: 90° Angle
Outlet: Straight

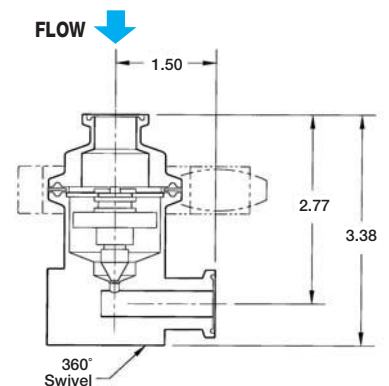

FDA403 Inlet: Straight
Outlet: 90° Angle

FDA500

Thermostatic Clean Steam Trap (Repairable)

Model	FDA500, FDA510
Sizes	1/2", 3/4", 1"
Connections	Tri-clamp, NPT, Tube Weld
Body Material	Stainless Steel
PMO Max. Operating Pressure	90 PSIG
TMO Max. Operating Temperature	Saturated Steam Temperature
PMA Max. Allowable Pressure	145 PSIG up to 338°F
TMA Max. Allowable Temperature	350°F @ 132 PSIG



Sanitary Clamp for Trap Body

TYPICAL APPLICATIONS

DRIP, PROCESS: The **FDA500 Series** thermostatic steam traps are used on clean steam applications as drip traps on piping runs as well as drainage for CIP/SIP systems and various process vessels.

HOW IT WORKS

The thermostatic trap contains a welded 316L stainless steel thermal element that expands when heated and contracts when cooled. When air and condensate are present the trap is in the open discharge position. When steam reaches the trap the element expands closing the trap tightly.

FEATURES

- All wetted parts are 316L stainless steel
- Electro-polish finish of **20-25** microinches RA on internal body
- Electro-polish finish of **25-32** microinches RA on external body
- Operates close to saturation curve to minimize condensate back-up
- Completely self-draining in the vertical downward flow orientation

SAMPLE SPECIFICATION

The steam Trap shall be all 316L stainless steel thermostatic type with a balanced pressure bellows that operates close to saturated steam temperatures. Internal body parts shall have an electro-polish finish of 20-25 microinches RA internally and a 25-32 finish externally. The unit shall have a split-body sanitary clamp design for easy maintenance. Trap shall be completely self-draining when mounted vertically.

INSTALLATION

Trap is designed for installation in a vertical, downward flow orientation to ensure that the self-draining clean steam requirement is satisfied. Isolation valves should be installed for maintenance purposes. For welded installations, removal of the body gasket and thermal element is necessary.

MAINTENANCE

Dirt is the most common cause of premature failure. Therefore, the upstream strainer should be periodically inspected and cleaned. For full maintenance details see Installation and Maintenance Manual.

MATERIALS

Body	Stainless Steel, AISI 316L
Gasket	Teflon/Encapsulated Viton
Element Plate	Stainless Steel, AISI 316L
Thermal Element	Stainless Steel, AISI 316L
Clamp	Stainless Steel, AISI 304

CAPACITIES – Condensate (lbs/hr)

Model	Orifice (inches)	Differential Pressure (PSI)					
		5	10	20	50	75	90
FDA500	9/64	140	240	400	690	850	950
FDA510	5/16	850	1200	1695	2690	3165	3400

Note: Capacities at 10°F below saturation.

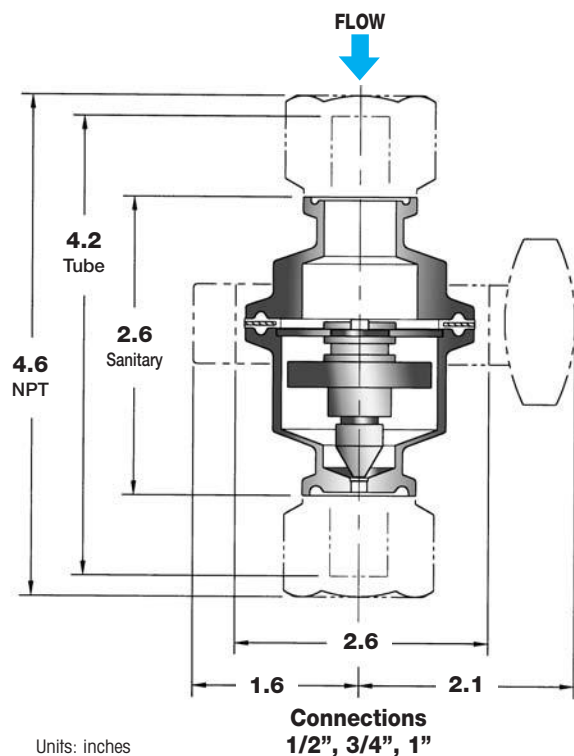

STEAM TRAPS

FDA600

Thermostatic Clean Steam Trap

Watson McDaniel reserves the right to change the designs and/or materials of its products without notice.
©2010 Watson McDaniel Company

Model	FDA600
Sizes	1/2", 3/4", 1"
Connections	Tri-clamp, NPT, Tube Weld
Body Material	Stainless Steel
PMO Max. Operating Pressure	110 PSIG
TMO Max. Operating Temperature	Saturated Steam Temperature
PMA Max. Allowable Pressure	145 PSIG up to 338°F
TMA Max. Allowable Temperature	350°F @ 132 PSIG



TYPICAL APPLICATIONS

DRIP, PROCESS: The **FDA600** Steam Traps are used on clean steam applications as drip traps on piping runs as well as drainage for CIP/SIP systems and various process vessels.

HOW IT WORKS

The thermostatic trap contains a welded 316L stainless steel thermal element that expands when heated and contracts when cooled. When air and condensate are present the trap is in the open discharge position. When steam reaches the trap the element expands closing the trap tightly.

FEATURES

- All wetted parts are 316L stainless steel
- Operates close to saturation curve to minimize condensate back-up
- Completely self-draining in the vertical downward flow orientation

SAMPLE SPECIFICATION

The Steam Trap shall be all 316L stainless steel thermostatic type with a balanced pressure bellows that operates close to saturated steam temperatures. The unit shall have a split-body design for easy maintenance. Trap shall be completely self-draining when mounted vertically.

INSTALLATION

The trap is designed for installation in a vertical, downward flow orientation to ensure that the self-draining clean steam requirement is satisfied. Isolation valves should be installed for maintenance purposes. For welded installations, removal of the body gasket and thermal element is necessary.

MAINTENANCE

Dirt is the most common cause of premature failure. Therefore, the upstream strainer should be periodically cleaned. For full maintenance details see Installation and Maintenance Manual.

MATERIALS

Body	Stainless Steel, AISI 316L
Thermal Element	Stainless Steel, AISI 316L
O-Ring, FDA Grade	Teflon Coated Silicone/FEP
Nuts & Bolts	Stainless Steel, AISI 316L

HOW TO SIZE/ORDER

Size/Model: **FDA600**, Specify pipe size and connections.

CAPACITIES – Condensate (lbs/hr)

Condensate Temp Below Saturation	Differential Pressure (PSI)						
	1	5	10	20	50	75	110
10 °F	32	105	175	290	615	805	1160
20 °F	42	115	225	440	1060	1500	1850
Cold Water	735	1070	1375	1900	3100	3500	4600

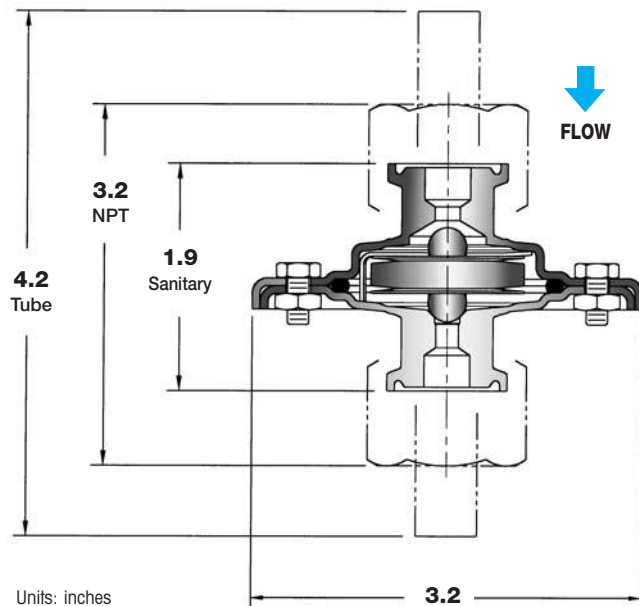

FDA800

Thermodynamic Clean Steam Trap

Model	FDA800
Sizes	1/2"
Connections	Tri-Clamp, NPT, Tube Weld
Body Material	Stainless Steel
PMO Max. Operating Pressure	150 PSIG
TMO Max. Operating Temperature	500°F
PMA Max. Allowable Pressure	230 PSIG @ 850°F
TMA Max. Allowable Temperature	850°F @ 230 PSIG



NPT



Tri-Clamp

TYPICAL APPLICATIONS

DRIP, PROCESS: The **FDA800 Series** Thermodynamic Clean Steam Traps are used in sanitary systems as drip traps on steam mains as well as for drainage on various process vessels such as separators and filters.

HOW IT WORKS

The thermodynamic trap has a cyclic on/off operation with a disc that is pushed open when condensate is present and pulled closed when steam tries to escape.

FEATURES

- Small and compact
- All 316L stainless steel components
- Works in any position (horizontal preferred)

SAMPLE SPECIFICATION

The steam trap shall be a thermodynamic disc type with an all 316L stainless steel construction and integral seat design. Unit shall be capable of installation in any orientation and self-draining when mounted vertically.

INSTALLATION

The trap can be installed in any position; however, horizontal is preferred. For self-draining or freezeproof requirements, the trap may be installed vertically. Installation should include a strainer and isolation valves for maintenance purposes.

MAINTENANCE

Dirt is the most common cause of premature failure. Therefore, the upstream strainer should be periodically cleaned. For full maintenance details see Installation and Maintenance Manual.

MATERIALS

Body	Stainless Steel, AISI 316L
Disc	Stainless Steel, AISI 316L
Cap	Stainless Steel, AISI 316L

HOW TO SIZE/ORDER

Size/Model: 1/2" **FDA800**, Specify connections.

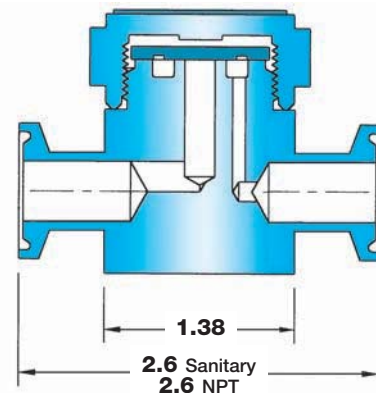

Units: Inches

CAPACITIES – Condensate (lbs/hr)

Size	Differential Pressure (PSI)											
	3.5	5	10	15	20	25	30	40	50	75	100	150
1/2"	180	185	190	195	200	215	220	230	250	310	375	500

Note: Maximum back pressure not to exceed 80% of inlet pressure.

STEAM TRAPS

WPN Series

Bi-Metallic Steam Traps

Watson McDaniel reserves the right to change the designs and/or materials of its products without notice.
©2010 Watson McDaniel Company

Model	WPN-40						WPN-63						
	1/2", 3/4", 1", 1 1/2", 2"						1/2", 3/4", 1"			1 1/2", 2"			
Sizes	1/2", 3/4", 1", 1 1/2", 2"						1/2", 3/4", 1"			1 1/2", 2"			
Connections	NPT, FLG, SW, Butt-weld						FLG, SW, Butt-weld			FLG, SW, Butt-weld			
Body & Cover Material	C22.8			SA105			SA182 F12			SA182 F12			
PMO Max Operating Pressure (PSIG)	470	325	220	520	470	420	825	690	660	590	825	735	660
TMO Max Operating Temperature (°F)	482	725	842	572	635	842	572	662	842	932	572	662	842
Max Press. Drop for Press. Controller (PSI)	470	325	190	470	325	190	680			825	470	470	
Pressure Controller	R32	R22	R13	R32	R22	R13	R46			R56	R32	R32	

Model	WPN-100			WPN-160				WPN-250			
	1/2", 3/4", 1"			1/2", 3/4", 1"				1/2", 3/4", 1"			
Sizes	1/2", 3/4", 1"			1/2", 3/4", 1"				1/2", 3/4", 1"			
Connections	FLG, SW, Butt-weld			FLG, SW, Butt-weld				FLG, SW, Butt-weld			
Body & Cover Material	SA182 F12			SA182 F22				SA182 F22			
PMO Max. Operating Pressure (PSIG)	1325	825	400	2250	1470	910	515	2700	2260	1580	1190
TMO Max. Operating Temperature (°F)	842	923	986	932	950	986	1022	932	950	986	1022
Max Press. Drop for Press. Controller (PSI)	1325	1325/880		1620				2260			
Pressure Controller	R90	R90/R60		R130				R154			

TYPICAL APPLICATIONS

DRIP, TRACER, PROCESS: The **WPN Series** of Bi-Metallic Steam Traps are used in steam tracing, steam main drips and non-critical process equipment. They can be used in outdoor applications that are subject to freezing. Bi-Metallic traps will back up some condensate into the system and should only be used when this condition is permissible.

HOW IT WORKS

When the system is cold the trap is wide open discharging air and cold condensate. When the bimetallic plates inside the trap heat up, they pull the seat closed and the flow becomes restricted. When steam temperature is reached the trap shuts off tightly.

FEATURES

- Excellent for high pressure and superheated steam applications
- Freezeproof and resistant to water hammer
- Suitable for superheated steam with check valve installed at inlet
- In-line repairable
- Trap can be welded into line

SAMPLE SPECIFICATION

Steam trap shall be Watson McDaniel WPN Series Bi-Metallic Steam Trap. Trap must be capable of being completely serviced while still in line.

INSTALLATION

The trap can be installed in a vertical or horizontal plane. See Installation and Maintenance Manual.

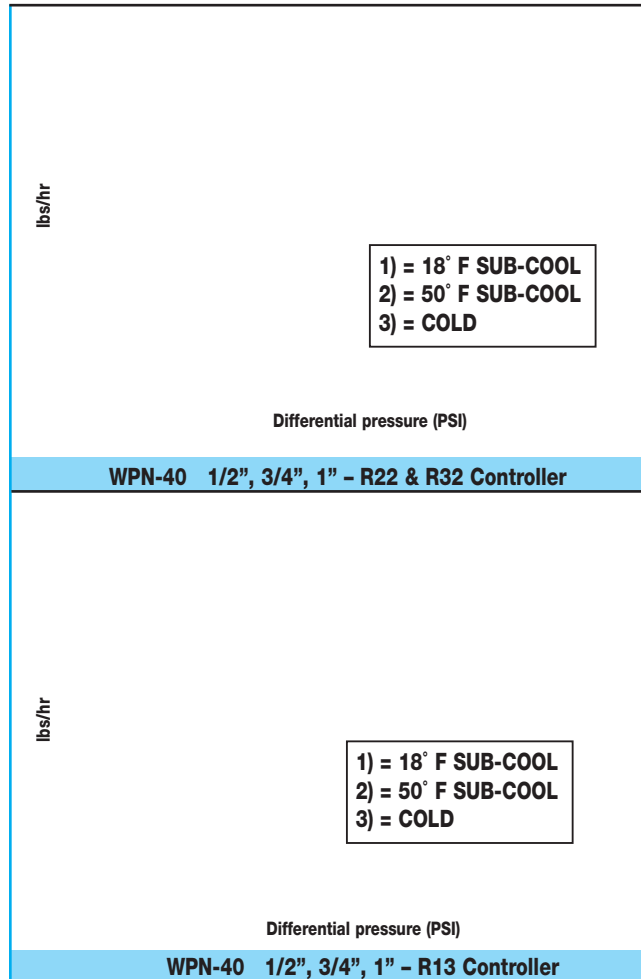

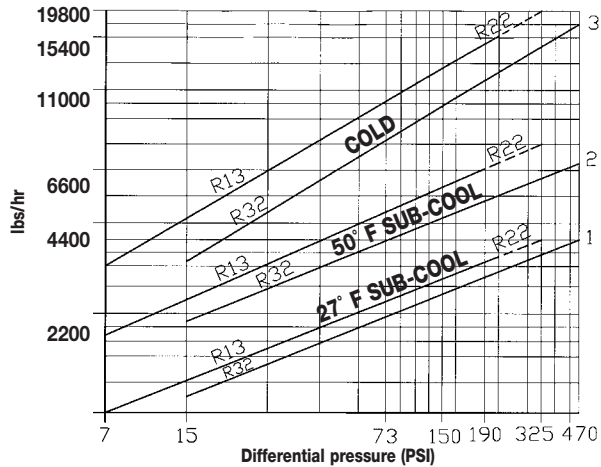

WPN-40 1 1/2", 2" R13, R22 & R32 Controller

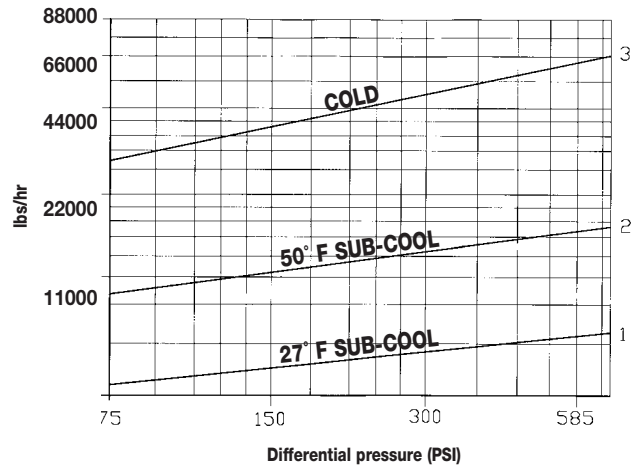

WPN-63 1/2", 3/4", 1"

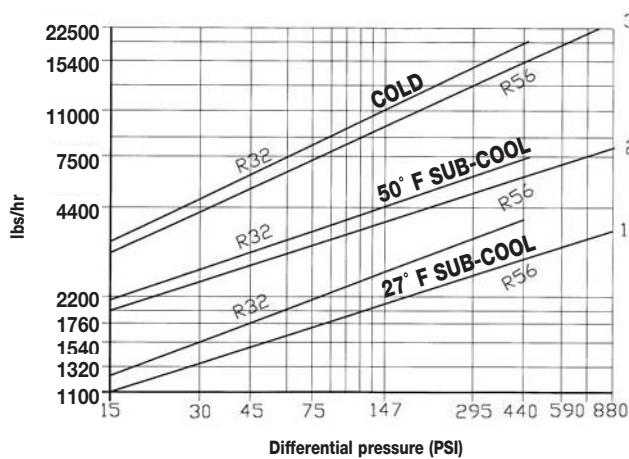

WPN-63 - 1 1/2", 2"

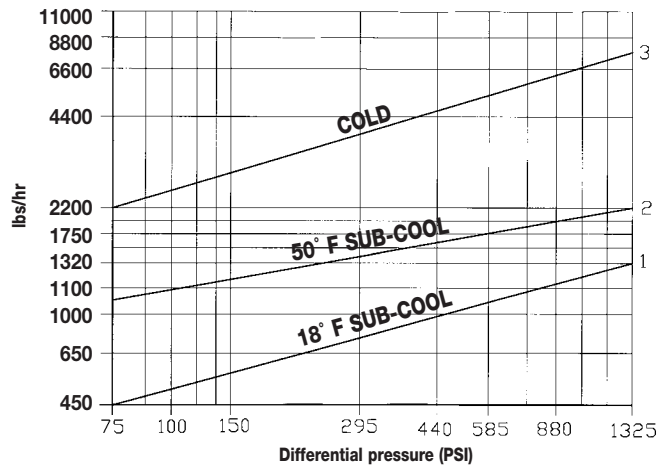

WPN-100 - 1/2", 3/4", 1"

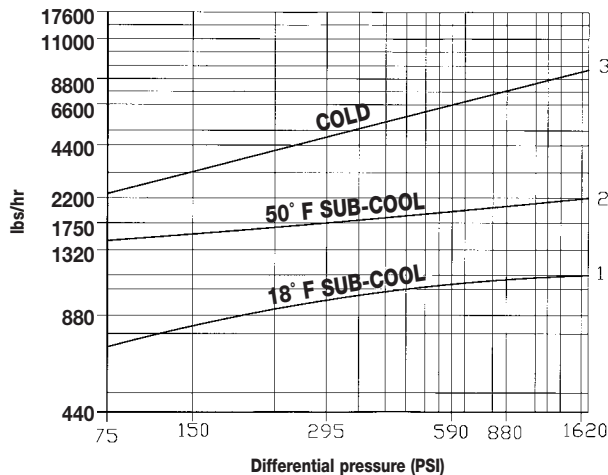

WPN-160 1/2", 3/4", 1"

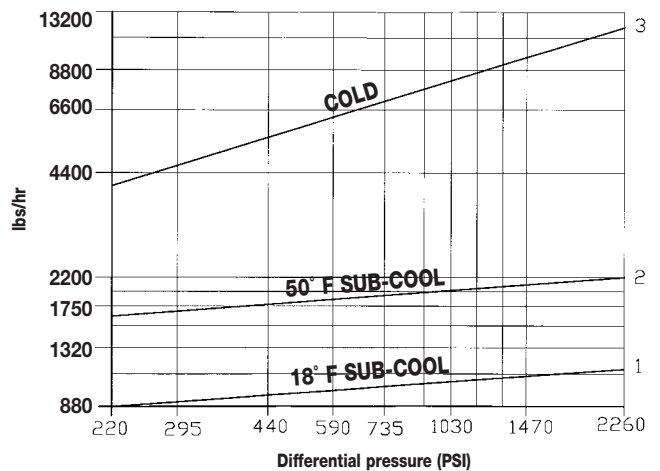

WPN-250 - 1/2", 3/4", 1"

STEAM TRAPS

WPN Series

Bi-Metallic Steam Traps

Watson McDaniel reserves the right to change the designs and/or materials of its products without notice.
©2010 Watson McDaniel Company

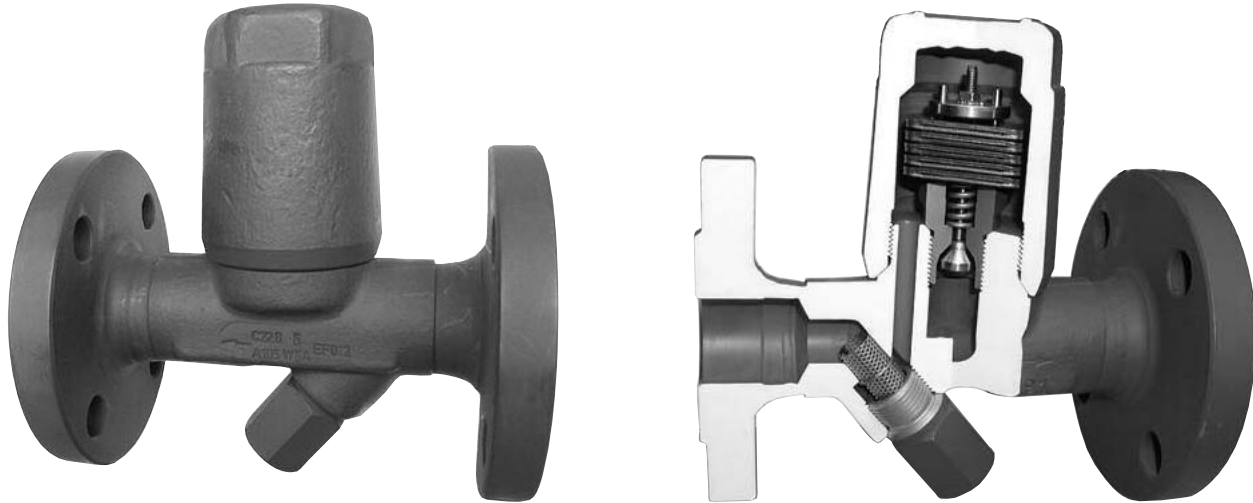

DIMENSIONS & WEIGHTS - inches/pounds								
Model	Size	Connection	L	H	H1	H2	H3	Weight (lbs)
WPN-40	1/2", 3/4"	FLG #150/300	6.0	3.92	2.48	.96	2.8	7.7
	1"	FLG #150/300	8.4	3.92	2.48	.96	2.8	9.2
	1 1/2", 2"	FLG #150/300	9.2	5.76	-	-	3.6	25.0
	1/2", 3/4"	NPT, SW	3.92	3.92	2.48	.96	2.8	3.7
	1"	NPT, SW	4.12	4.12	2.20	.52	2.8	4.6
	1 1/2"	NPT, SW	5.2	5.76	-	-	3.6	17.6
	2"	NPT, SW	8.4	5.76	-	-	3.6	17.6
	1/2", 3/4", 1"	Butt-weld	10.0	3.92	2.48	.96	2.8	5.0
	1 1/2", 2"	Butt-weld	10.0	5.76	-	-	3.6	21.0
WPN-63	1/2", 3/4", 1"	FLG #600	8.4	4.16	1.68	-	2.8	17.6
	1 1/2"	FLG #600	10.4	5.76	-	-	3.6	29
	2"	FLG #600	12.0	5.76	-	-	3.6	30.8
	1/2", 3/4", 1"	SW	6.4	4.16	1.68	-	2.8	10.0
	1 1/2"	SW	5.2	5.76	-	-	3.6	17.6
	2"	SW	8.4	5.76	-	-	3.6	17.6
	1/2", 3/4", 1"	Butt-weld	6.4	4.16	1.68	-	2.8	10.0
	1 1/2", 2"	Butt-weld	10.0	5.76	-	-	3.6	21
WPN-100	1/2", 3/4"	FLG #600	8.4	4.16	1.68	-	2.8	14.0
	1"	FLG #600	9.2	4.16	1.68	-	2.8	20.5
	1/2", 3/4", 1"	SW	6.4	4.16	1.68	-	2.8	10.0
	1/2", 3/4", 1"	Butt-weld	6.4	4.16	1.68	-	2.8	10.0
WPN-160 *	1/2", 3/4"	FLG #900/1500	8.4	4.16	1.68	-	2.8	14.0
	1"	FLG #900/1500	9.2	4.16	1.68	-	2.8	21.0
WPN-250 *	1/2", 3/4", 1"	SW	6.4	4.16	1.68	-	2.8	10.3
	1/2", 3/4", 1"	Butt-weld	6.4	4.16	1.68	-	2.8	10.3

* WPN-160 FLG is 900#; WPN-250 FLG is 1500#.

STEAM TRAPS

WPN Series

Bi-Metallic Steam Traps

WPN-40

1/2", 3/4", 1"

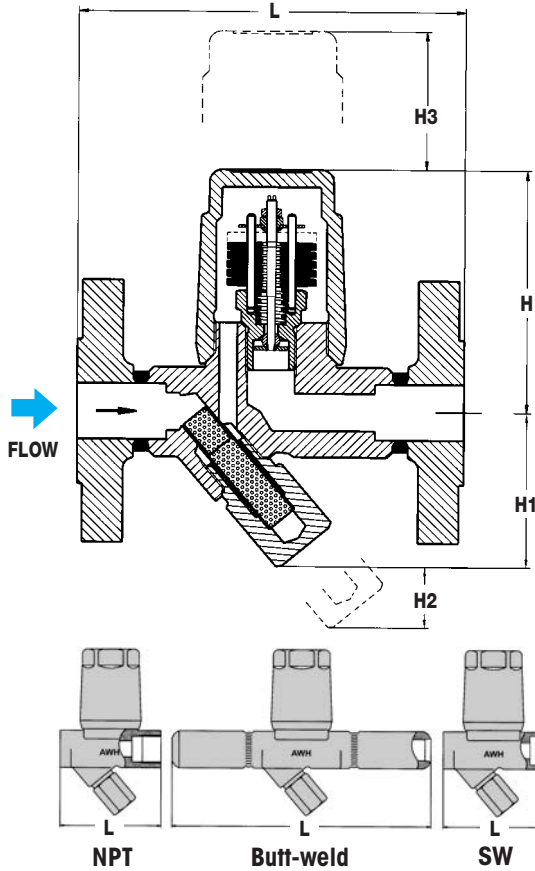

WPN-40/63

1 1/2", 2"

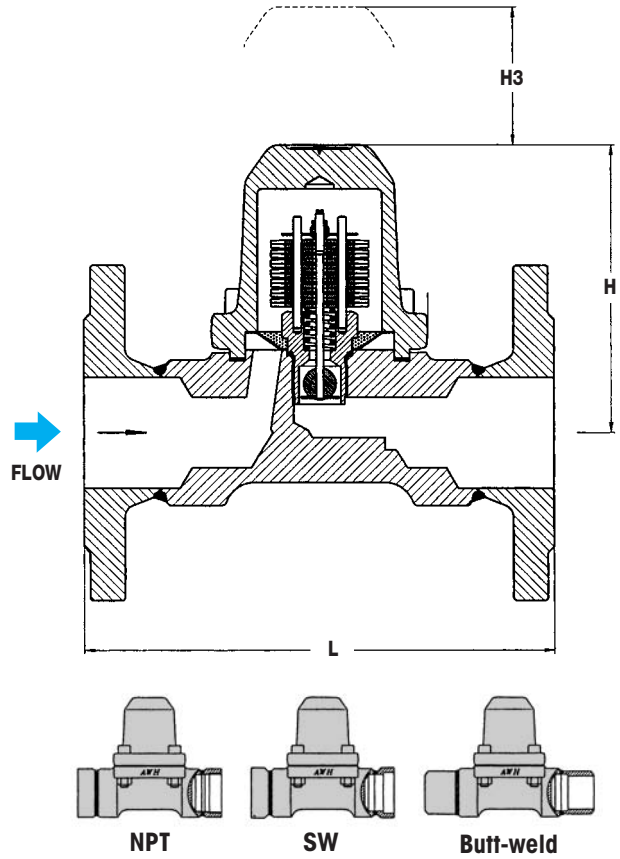

WPN-63/100/160/250

1/2", 3/4", 1"

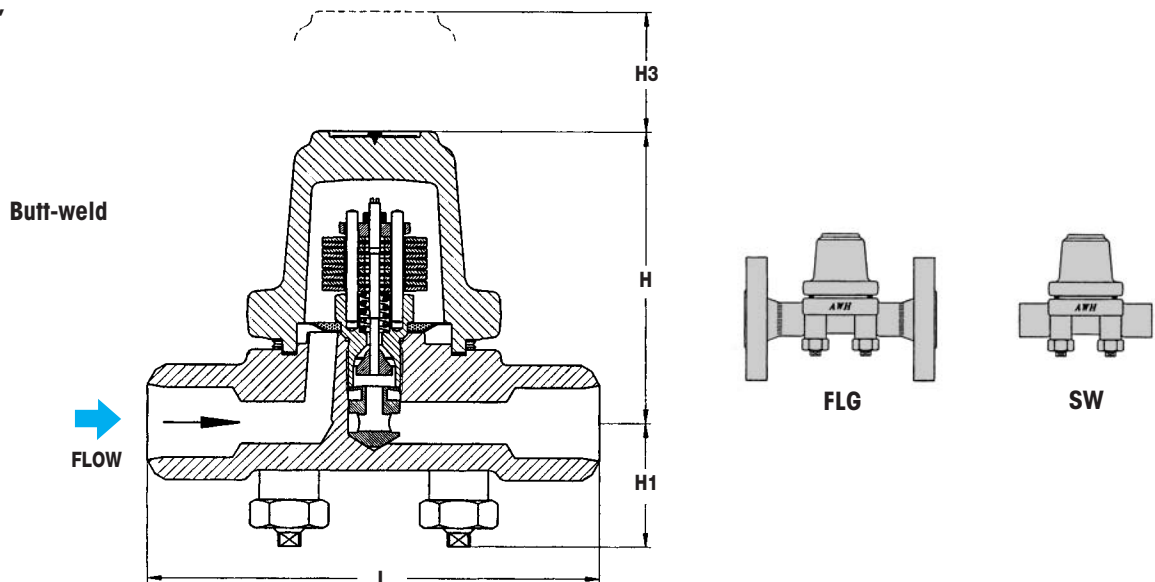

STEAM TRAPS

FM/FSM Series Manifolds

Watson McDaniel reserves the right to change the designs and/or materials of its products without notice.
©2010 Watson McDaniel Company

Model	FM	FSM
Sizes	1/2", 3/4"	1/2", 3/4"
Connections	NPT, SW	NPT, SW
Body Material	Fabricated Carbon Steel	Forged Steel
PMO Max. Operating Pressure	720 PSIG	600 PSIG
Pressure/Temperature Rating	720 PSIG @ 508°F	600 PSIG @ 500°F

TYPICAL APPLICATION

The **FM /FSM Manifolds** are used for steam distribution to the tracing system and for condensate collection. Typically used in chemical plants, petrochemical plants, textile industries, rubber plants and general industry. Manifolding your distribution and condensate collection system not only cuts down on installation and maintenance time, but also provides freeze protection.

DESCRIPTION FM

The **FM Manifold** is equipped with threaded or socket welded mount holes for ease of installation. Condensate collection manifolds are provided with a built-in siphon tube to minimize bi-phase flow, which reduces water hammer, and allows flash steam space to prevent isolation station freeze damage.

DESCRIPTION FSM

The **FSM Manifold** has a sealing system that utilizes an austenitic stainless steel piston that slides into two rings, one upper made of reinforced graphite, and one lower made of graphite interposed with thin stainless steel plates. The sealing surface is the surface of the piston. By tightening the bonnet nuts that are on the spring washers, a constant load on the upper ring is obtained, securing a tight seal to atmosphere. The same load, through the upper ring and the lantern, is applied to the lower ring that by expanding toward the body wall and toward the surface of the piston when the valve is in the closed position, ensures a perfect seal of the valve against the flow of the fluid.

FEATURES

- Compact design saves valuable plant space
- Available in 4, 6, 8 & 12 branch designs
- Available with preassembled steam trap stations
- Standard designs or custom built manifolds available
- Provides freeze protection
- Reduces installation and maintenance time
- On **FSM Model** valve bonnets are long neck type to allow for installation of insulation, keeping surface temperatures low for protection of personnel



FM Manifold (Carbon Steel)

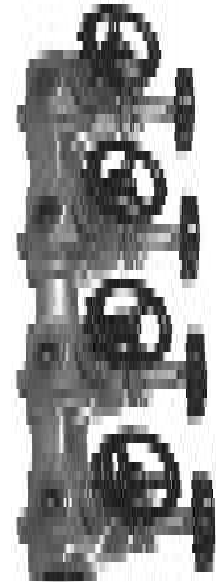

FSM Manifold (Forged Steel)

MATERIALS – FM

Body	Carbon Steel
------	--------------

MATERIALS – FSM

Body	Forged Steel, A105
Hand Wheel	Sheet Metal
Bonnet	Forged Steel, A105
Valve ring above	Graphite
Valve ring below	Graphite/Stainless Steel
Piston	Stainless Steel, A304

FM Series Carbon Steel Manifolds

DIMENSIONS & WEIGHTS – inches / pounds

FM Series Description	Condensate Inlet Connection Cl. 3000 Per ANSI B16.11					B Length	Weight (lbs)
	A		# Conn. on Side	# Conn. on Front	Conn. Total		
	Size	Type					
Vertical Coll. Manifold w/ 4 Side Conn. 1/2" NPT Carbon Steel	1/2"	NPT	4	0	4	24	25
Vertical Coll. Manifold w/ 4 Side Conn. 1/2" SW Carbon Steel	1/2"	SW	4	0	4	24	25
Vertical Coll. Manifold w/ 4 Side Conn. 3/4" NPT Carbon Steel	3/4"	NPT	4	0	4	24	27
Vertical Coll. Manifold w/ 4 Side Conn. 3/4" SW Carbon Steel	3/4"	SW	4	0	4	24	27
Vertical Coll. Manifold w/ 4 Side & 2 Front Conn. 1/2" NPT Carbon Steel	1/2"	NPT	4	2	6	24	27
Vertical Coll. Manifold w/ 4 Side & 2 Front Conn. 1/2" SW Carbon Steel	1/2"	SW	4	2	6	24	27
Vertical Coll. Manifold w/ 4 Side & 2 Front Conn. 3/4" NPT Carbon Steel	3/4"	NPT	4	2	6	24	29
Vertical Coll. Manifold w/ 4 Side & 2 Front Conn. 3/4" SW Carbon Steel	3/4"	SW	4	2	6	24	29
Vertical Coll. Manifold w/ 8 Side Conn. 1/2" NPT Carbon Steel	1/2"	NPT	8	0	8	40	40
Vertical Coll. Manifold w/ 8 Side Conn. 1/2" SW Carbon Steel	1/2"	SW	8	0	8	40	40
Vertical Coll. Manifold w/ 8 Side Conn. 3/4" NPT Carbon Steel	3/4"	NPT	8	0	8	40	42
Vertical Coll. Manifold w/ 8 Side Conn. 3/4" SW Carbon Steel	3/4"	SW	8	0	8	40	42
Vertical Coll. Manifold w/ 8 Side & 4 Front Conn. 1/2" NPT Carbon Steel	1/2"	NPT	8	4	12	40	46
Vertical Coll. Manifold w/ 8 Side & 4 Front Conn. 1/2" SW Carbon Steel	1/2"	SW	8	4	12	40	46
Vertical Coll. Manifold w/ 8 Side & 4 Front Conn. 3/4" NPT Carbon Steel	3/4"	NPT	8	4	12	40	48
Vertical Coll. Manifold w/ 8 Side & 4 Front Conn. 3/4" SW Carbon Steel	3/4"	SW	8	4	12	40	48
Vertical Coll. Manifold w/ 12 Side Conn. 1/2" NPT Carbon Steel	1/2"	NPT	12	0	12	56	56
Vertical Coll. Manifold w/ 12 Side Conn. 1/2" SW Carbon Steel	1/2"	SW	12	0	12	56	56
Vertical Coll. Manifold w/ 12 Side Conn. 3/4" NPT Carbon Steel	3/4"	NPT	12	0	12	56	58
Vertical Coll. Manifold w/ 12 Side Conn. 3/4" SW Carbon Steel	3/4"	SW	12	0	12	56	58

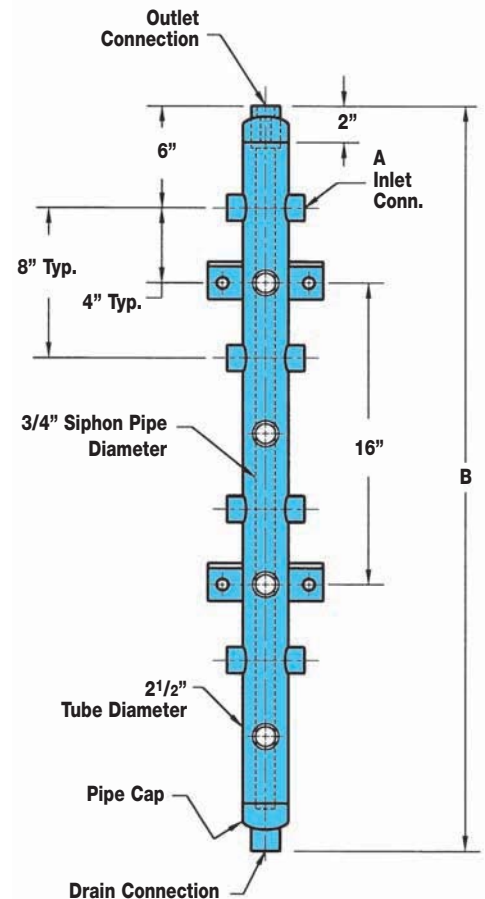
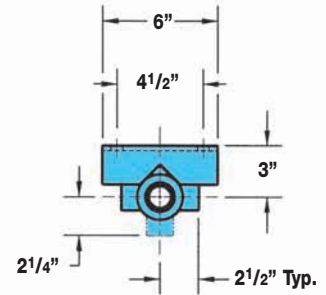

STEAM TRAPS

FSM Series

Forged Steel Manifolds

Watson McDaniel reserves the right to change the designs and/or materials of its products without notice.
©2010 Watson McDaniel Company

DIMENSIONS & WEIGHTS – inches/pounds

Model	L	H	D	C	O	I	S	S1	S2	A	A1	B	B1	No. of Valves	No. of Holes	Weight (lbs)
FSM-4	4.33"	1.61"	3.94"	8.97"	10.63"	6.30"	13.03"	-	-	2.79"	1.22"	3.23"	2.79"	4	2 (M12)	23
FSM-8	4.33"	1.61"	3.94"	8.97"	10.63"	6.30"	-	28.1"	-	2.79"	1.22"	3.23"	2.79"	8	4 (M12)	49
FSM-12	4.33"	1.61"	3.94"	8.97"	10.63"	6.30"	-	-	36.22"	2.79"	1.22"	3.23"	2.79"	12	6 (M12)	72

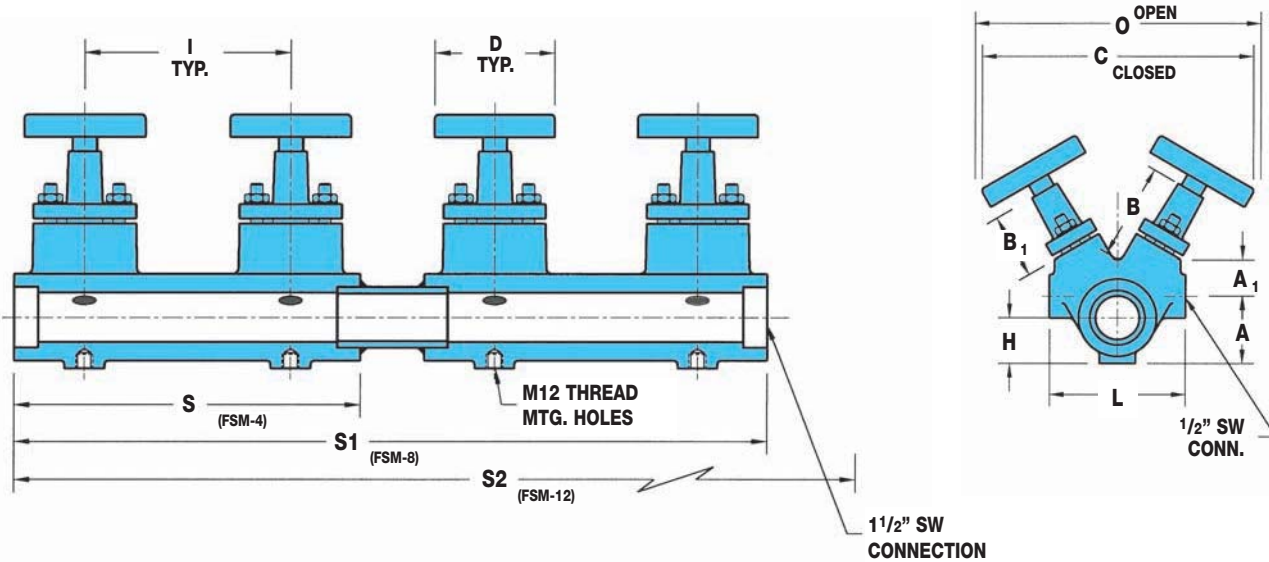

CAPACITIES

Pressure (PSIG)	Condensate (lbs/hr) ¹	Steam (lbs/hr) ²
25	1850	160
50	1000	310
75	840	460
100	610	730
125	660	760
150	620	900
200	570	1200
250	535	1500
300	510	1800
400	470	2350
500	460	3000
600	440	3550

¹Saturated condensate discharging into 20 PSI back pressure

²Saturated Steam flow @ 5000 ft/min velocity

Condensate Return Pumps



Condensate Return Pumps

Stand Alone Pressure Motive Pumps

Page No.

The stand alone **Pressure Motive Pump (PMP)** consists of the pump tank, the internal operating mechanism, and a set of inlet and outlet check valves. Depending on the particular model, pump tanks can be made from Ductile Iron, Fabricated Steel or Stainless Steel. In most installations an additional receiver or reservoir tank and possibly a high capacity steam trap may be required to complete the system.

76-89

Introduction

Pressure Motive Pump (PMP) Series

76-81



PMPC

Basic Pumping Applications up to 200 PSIG

82

- Ductile Iron body (PMO 200 PSIG)
- Patented Snap-Assure Mechanism with Inlet and Outlet Check Valves



PMPF

Basic Pumping Applications up to 200 PSIG

83

- Fabricated Carbon Steel body (PMO 200 PSIG)
- Patented Snap-Assure Mechanism with Inlet and Outlet Check Valves



PMPSS

Corrosive Applications up to 150 PSIG

84

- Fabricated Stainless Steel body (PMO 150 PSIG)
- Patented Snap-Assure Mechanism with Inlet and Outlet Check Valves



PMPLS

Low-Profile Applications up to 150 PSIG

85

- Fabricated Carbon Steel body (PMO 150 PSIG)
- Patented Snap-Assure Mechanism with Inlet and Outlet Check Valves



PMPM

Extremely Low-Profile Applications up to 150 PSIG

86

- Cast Iron body (PMO 150 PSIG)
- Internal Pump Mechanism with Inlet and Outlet Check Valves



PMPBP

High-Capacity Applications up to 150 PSIG

87

- Fabricated Carbon Steel body (PMO 150 PSIG)
- Internal Pump Mechanism with Inlet and Outlet Check Valves



PMPSP

Sump Drainer

88-89

- Fabricated Carbon Steel body (PMO 150 PSIG)
- These non-electric sump drainers are designed to drain unwanted water from sumps, pits, underground tunnels and low lying areas
- Patented Snap-Assure Mechanism with Inlet and Outlet Check Valves

Condensate Return Pumps

Pumps with Receiver Tanks

Page No.

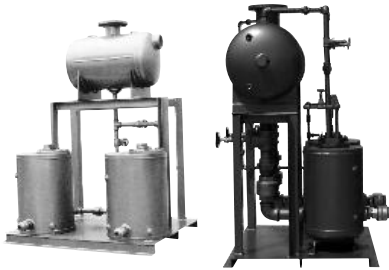

Simplex, Duplex, Triplex & Quadraplex Systems

90-91

Standardized Simplex, Duplex, Triplex, and Quadraplex packaged systems include the Stand Alone Pumps and check valves with receiver tank mounted on a steel base and frame. Multiple pumping units can be used for increased capacity or for system redundancy. The units are available in Ductile Iron, Carbon Steel and Stainless Steel.

Additional options such as sight glasses, insulation jackets, cycle counters, motive and vent piping, pressure regulators, steam traps, strainers and ASME code stamps, etc., are available.

Pump & Trap Combinations

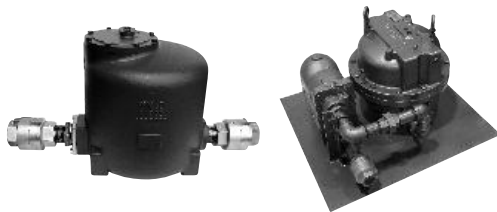

Models PMPT & WPT

92-97

Pump & trap combinations are used for draining condensate from a single piece of heat transfer equipment. Model **PMPT** has an internal steam trap inside the pump body. The **WPT Series** have an appropriately sized external steam trap attached to the pump and are mounted on a common base.

ACCESSORIES & OPTIONS for Stand Alone Units

Custom Tanks, Insulation Jackets, Gauge Glasses, Cycle Counters, Pre-piped Accessories, Mechanisms, Check Valves, etc.

98-99

SIZING & SELECTION for All Non-Electric Pumps & Systems

Pump Capacities
PMP, Receiver & Vent, Pump-Trap & Reservoir Sizing

100-101

102-109

Customized Skid Packages

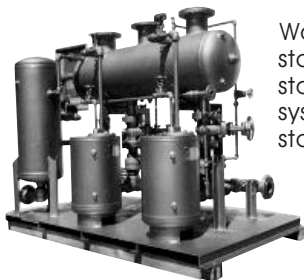

Watson McDaniel's fully equipped ASME qualified fabrication facility stands ready to assist you with all your fabrication needs. Our engineering staff specializes in the design of pressure motive condensate pumping systems for both industrial and institutional applications. We offer either standard packages, or specialized systems to meet your specific needs.

110-111

Electric Condensate Pumps



Models W4100 & W4200

112-115

Electric condensate pumps are available for condensate temperatures up to 190°F. Carbon Steel and Cast Iron Tanks available. Available options include receivers, NEMA control panels, mechanical and electrical alternators, magnetic starters, gauge glasses, and more.

Pumps NON-ELECTRIC CONDENSATE PUMPS

Why use a Pressure Motive Pump (PMP)?

The primary function of the non-electric PMPs is to return condensate back to the boiler. They are an excellent alternative to standard electric pumps that are prone to seal failure when pumping hot condensate in excess of 195° F. They also significantly improve the performance and efficiency of heat exchangers by helping to drain condensate from the heat exchanger during system stall conditions.

Information Required for Proper Selection and Sizing of Pressure Motive Pump (PMP) Systems

Although Pressure Motive Pumps can be supplied as stand-alone units, the vast majority of industrial condensate transfer applications require a complete system of components to function both properly and efficiently. This section is intended to familiarize the user with the information and components required to provide an efficient system.

Considerations for PMP System Sizing and Selection

- 1) **Is a PMP required for the situation?** Is there sufficient line pressure for adequate transfer of condensate, or is a PMP required to overcome lift and/or condensate return line pressure?
- 2) **Should you choose a Stand-alone pump or Pump with Receiver Tank (PMP System)?** The vast majority of pump applications require some type of receiver or reservoir upstream of the unit for several possible reasons:



- To allow proper operation of the PMP by providing adequate liquid head above the PMP (Fill Height). Liquid fill head is required to ensure gravity drainage of condensate so that the PMP tank may fill completely on each cycle.
- To enable the condensate to collect while the pump is in the discharge cycle (i.e. not filling), thus preventing liquid backup into the equipment being drained.
- In an open loop system, a vented receiver must accommodate both high pressure/temperature condensate as well as the flash steam generated from that condensate. Sizing of both the receiver and vent connection are critical to proper function of the system.

3) Application – **OPEN LOOP** (Vented Receiver) or **CLOSED LOOP** (Pressurized Reservoir)?

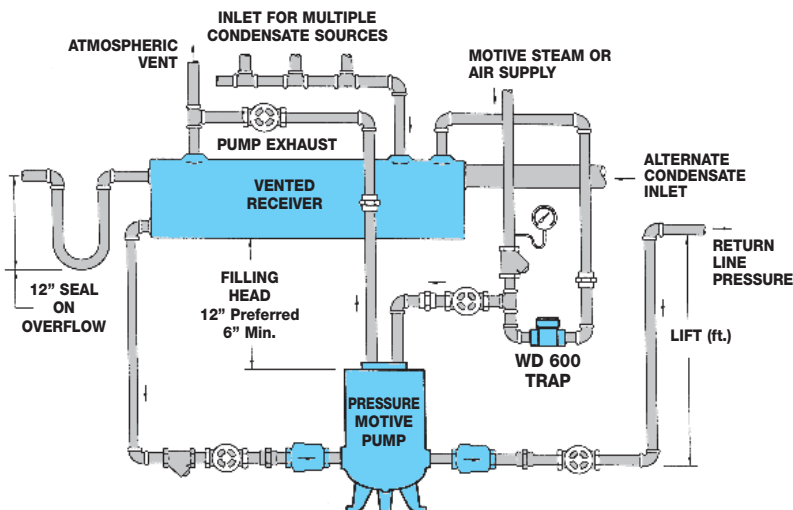

OPEN LOOP (Vented Receiver)

This PMP System is intended for the drainage of multiple condensate sources. For these applications, a vented receiver will be required for the equalization of the various pressure sources. The flash steam generated by the hot condensate in the receiver tank can be used for supplementing other low pressure steam systems or vented to atmosphere.

Pumps NON-ELECTRIC CONDENSATE PUMPS

▶ CLOSED LOOP (Pressurized Reservoir)

STALL CONDITION WITH MODULATED STEAM FLOW

When a modulating valve is used to control product temperature in heat transfer equipment, the valve will open and close as necessary to meet the variable demand of the system to maintain the product at constant temperature (Figure 1). Therefore, when maximum heating is required, the supply valve will be fully open to satisfy the high steam demand requirement. At this point, pressure is also being supplied at its highest level, which may be sufficient to overcome total system back pressure.

As the product temperature is satisfied, demand decreases and the valve correspondingly begins to close reducing pressure differential. If demand is satisfied, the valve modulates to its fully closed position. Inlet supply pressure will eventually fall below system back pressure, resulting in system stall. This leads to poor heat transfer and water hammer as condensate backs up in the heat transfer equipment. To prevent this situation, a pressure motive pump (PMP) and steam trap is added to the system (Figure 2). Any condensate forming inside the heat transfer equipment will drain by gravity into the pump tank. The condensate will accumulate in the pump tank until the float mechanism reaches its trip point. The "tripping" of the mechanism opens the motive valve to allow high pressure steam into the tank to drive the condensate from the tank to the condensate return line.

Figure 1

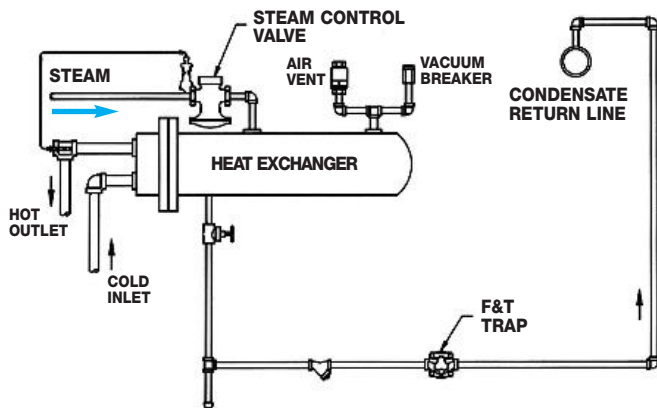

Heat Exchanger System without PMP

Figure 2

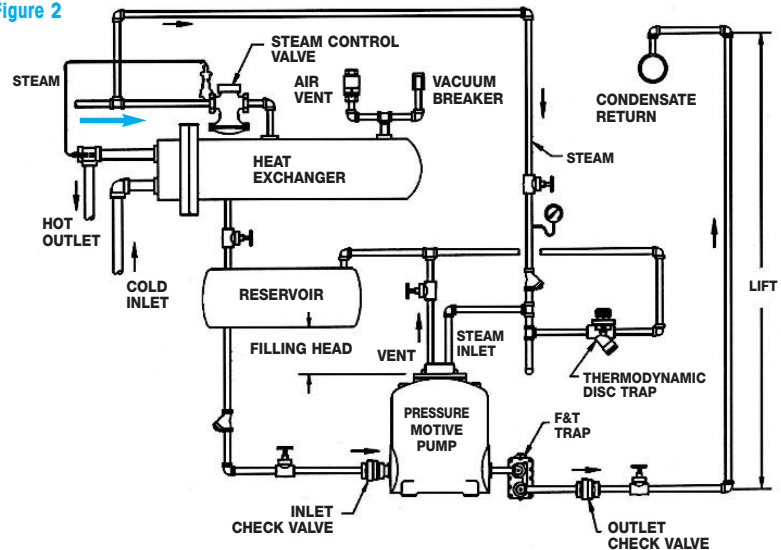

Heat Exchanger System with PMP & Separate Trap (Closed Loop System)

- 4) **Height or spatial limitations** – Is the equipment to be drained low to the ground or are there other size limitations? It is important that minimum fill head requirements are met to ensure proper operation of the PMP. In addition, changes in fill head will affect capacity.
- 5) **Standard Simplex/Duplex/Triplex/Quadruplex or Custom System** – This is generally dictated by sizing requirements and application parameters, but a cost-effective standard system should be selected when possible. Custom fabricated systems are designed to meet a wide variety of specific application requirements. **Note: The sizing of the receiver and vent connection on standard systems must be specified per the application parameters.**
- 6) **Back pressure** – For proper sizing and selection of a PMP system, the total back pressure of the system must be known. The total back pressure generally consists of:
 - The vertical height the condensate must be raised (Every 1 foot of vertical lift equals 0.433 PSI pressure.)
 - Any line pressure in the condensate return piping
- 7) **Motive Gas and Pressure** – Is the gas (steam, air, other) appropriate for the application and is the available pressure sufficient to provide the necessary flow against the total back pressure? (For closed loop systems, only steam is appropriate as a motive.)

NON-ELECTRIC CONDENSATE PUMPS

PMP Series

Pressure Motive Pumps

Watson McDaniel reserves the right to change the designs and/or materials of its products without notice.
©2010 Watson McDaniel Company

TYPICAL APPLICATIONS

The Watson McDaniel **PMP Series of Pressure Motive Pumps** are designed to transfer hot condensate (as well as other liquids) without the use of electrical energy. The primary application for the PMP is pumping condensate from a process application or condensate collection area back to the condensate return system.

Hot Condensate The mechanical seals in standard electric condensate return pumps begin to have difficulty when handling condensate in excess of 195° F. Seal failure is virtually guaranteed when condensate temperatures reach 203° F due to flashing of the condensate across the seal face. It is therefore required to cool condensate in order to prevent seal failure prior to pumping using electric pumps. PMPs do not have seals and therefore will handle condensate well in excess of these temperatures.

TYPICAL CONFIGURATIONS

STAND ALONE UNITS:

All stand alone units are furnished with pump tank, check valves: and internal pumping mechanism.

- PMPC • PMPF • PMPSS • PMPLS • MPPM • PMPBP

PUMPS WITH RECEIVER TANKS:

One or more stand alone pump units connected to an appropriately sized receiver tank mounted on a common base. Additional pumping units can be used for increased capacity or pump redundancy in case of failure.

Simplex: One Pumping unit with check valves and receiver tank, mounted on frame and skid base.

Duplex: Two Pumping units with check valves and receiver tank, mounted on frame and skid base.

Triplex: Three Pumping units with check valves and receiver tank, mounted on frame and skid base.

Quadraplex: Four Pumping units with check valves and receiver tank, mounted on frame and skid base.

PUMP & STEAM TRAP COMBINATIONS:

Stand alone pump combined with Internally or Externally configured Steam Trap.

- PMPT (Internal Steam Trap)
- WPT Series (External Steam Trap)

SUMP DRAINER:

Stand alone Sump Drainer with check valves is designed for pumping water out of low lying areas or pits. Excellent solution where there is no access to electricity.

- PMPSP

CUSTOM CONFIGURATIONS

Watson McDaniel's fully-qualified fabrication facility is ASME code certified. Our engineers can design and build complete custom systems to meet all your requirements.

Several choices of pump body materials, types and configurations are available to meet specific customer applications:

Ductile Iron Tanks Ductile Iron is far superior to cast iron in handling higher pressures and temperatures. Ductile iron is also extremely corrosion resistant to condensate and water and can last in excess of 50 years before tank replacement is required. Our ductile iron tanks can be ASME coded on request.

Fabricated Carbon Steel Carbon steel has a higher pressure and temperature rating than ductile iron. Certain industrial facilities such as chemical and petrochemical refineries request carbon steel only. Our carbon steel tanks are standard ASME coded.

Fabricated Stainless Steel Stainless steel (304L) tanks are the most corrosion resistant and can be used in extremely harsh environments.

Low Profile Low profile tanks are often required when draining condensate from process equipment when positioned close to the ground which limits filling head. Low profile units are available in both fabricated steel and cast iron.

Sump Drainers Sump drainers are similar to the standard PMP models except that they discharge the condensate vertically upwards. This piping configuration allows them to easily fit into below ground sump pits with limited space.

FEATURES

- **Seal-less** – The PMP contains no seals. The weak point in conventional electric pumps is seal failure due to flashing hot condensate across the seal face.
- **Non-Electric** – Since no electricity is required they can be used in remote locations or NEMA 4, 7 & 9 hazardous areas. Can operate using steam, air, nitrogen or other pressurized gases as the motive force.
- **Ductile-Iron** – Pump tanks are standard in Ductile Iron which is far superior to Cast Iron for pressure and temperature rating and safety. Can be ASME coded and can last in excess of fifty years prior to replacement.
- **Carbon Steel** – Pump tanks available in ASME coded carbon steel.
- **Stainless Steel** – Pump tank options include 304L for applications in harsh environments.

OPTIONS

- Pump cycle counter used for predicting maintenance intervals as well as calculating the volume of condensate pumped.
- Insulation jackets are available to stop heat losses through the pump body and provide personal protection.
- Sight glass for monitoring liquid level inside pump body.
- Customized systems – ASME code-certified fabrication facility

NON-ELECTRIC CONDENSATE PUMPS

PMP Series

Pressure Motive Pumps

STAND ALONE UNITS

All stand alone units are furnished with pump tank, check valves and internal pumping mechanism.



PMPC DUCTILE IRON

The Model **PMPC** pressure motive pump body & cover are manufactured from ductile iron. **ASME "UM" code stamp is available.**



PMPF CARBON STEEL HIGH-PRESSURE

The Model **PMPF** pressure motive pump is designed for high pressure applications. Pump body & cover are manufactured from carbon steel and receive the **ASME "UM" code stamp.**



PMPSS STAINLESS STEEL

The Model **PMPSS** pressure motive pump body & cover are manufactured from 304L stainless steel. These tanks are designed to be used in harsh corrosive environments and receive the **ASME "UM" code stamp.**



PMPBP CARBON STEEL HIGH-CAPACITY

The **PMPBP** is an extremely high-capacity pressure motive pump for applications requiring large transfer of condensate or other liquids. The internal operating mechanism functions identically to other pumps in the PMP series. **ASME "U" code stamp is available.**

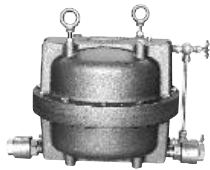

PMPM CAST IRON LOW PROFILE

The Model **PMPM** pressure motive pump has an extremely low profile. These low-profile tanks are required when draining condensate from process equipment positioned close to the ground which limits the filling head of the pump.



PMPLS CARBON STEEL LOW PROFILE

The Model **PMPLS** pressure motive pumps are low profile. These tanks are often required when draining condensate from process equipment positioned close to the ground which limits the filling head of the pump. Pump body & cover are manufactured from carbon steel and receive the **ASME "UM" code stamp.**

PUMP & TRAP COMBINATIONS

with Internal Steam Trap



PMPT

The Model **PMPT** low-profile pressure motive pump comes with an Internal Steam Trap. It is an excellent choice for drainage of various modulating process equipment. **The internal steam trap allows condensate discharge under all operating conditions of modulating equipment, including vacuum.**

with External Steam Trap



WPT

The **WPT Series** are stand alone pump units with an appropriately sized External Steam Trap preassembled at the factory and mounted on a common base plate, allowing for easy installation. Available in several sizes and capacities. Used when load requirement exceeds that of the PMPT.

PUMPS WITH RECEIVER TANKS



Watson McDaniel manufactures PMPs with receiver tanks. Pumps are available in Ductile Iron, Cast Iron or Fabricated Steel. Receiver tank manufactured from Carbon Steel. Available in Simplex, Duplex, Triplex and Quadraplex.

SUMP DRAINER



PMPSP

The Model **PMPSP** sump drainer body & cover are manufactured from Carbon Steel. The Model PMPSP Sump Drainer is designed for pumping out and draining pits.

NON-ELECTRIC CONDENSATE PUMPS

PMP Series

Pressure Motive Pumps

Watson McDaniel reserves the right to change the designs and/or materials of its products without notice.
©2010 Watson McDaniel Company

PUMPS

Operation of PMP Pressure Motive Pump

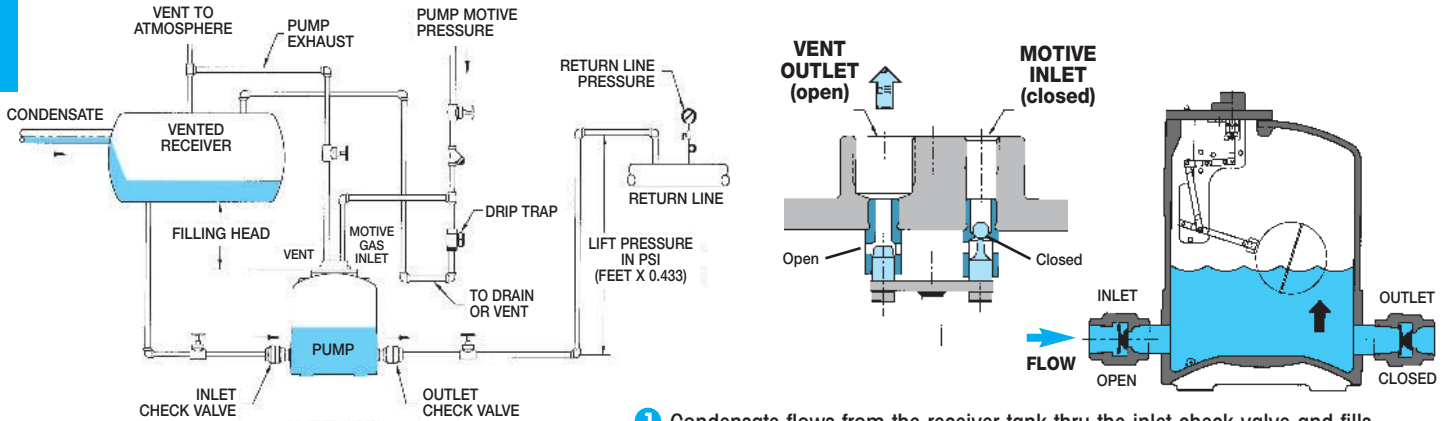

1 Condensate flows from the receiver tank thru the inlet check valve and fills the pump tank. During the filling cycle the float inside the tank rises.

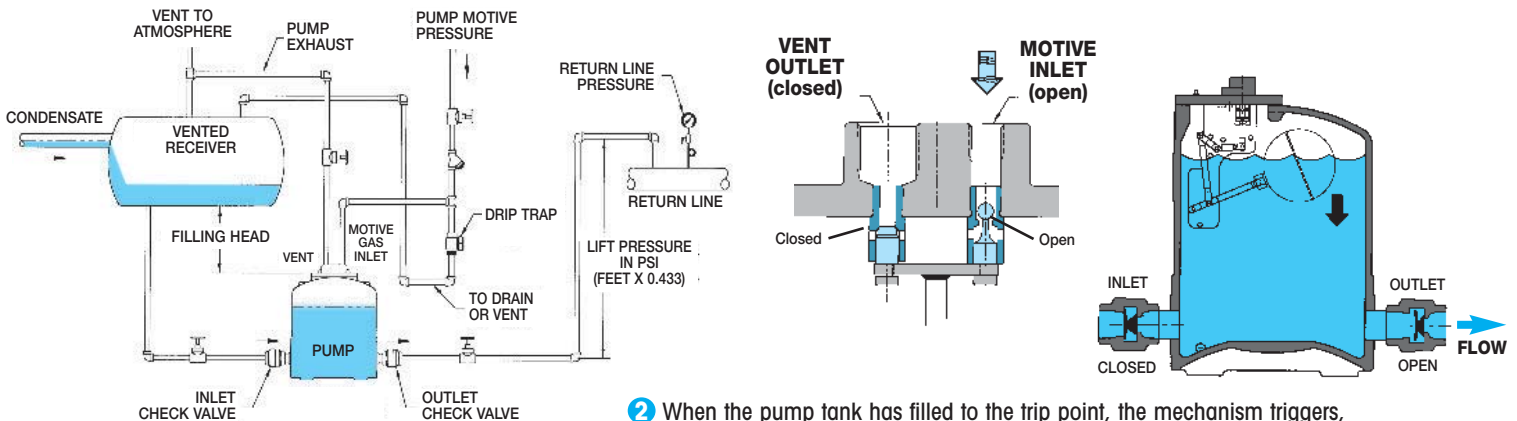

2 When the pump tank has filled to the trip point, the mechanism triggers, opening the motive gas inlet valve and simultaneously closing the vent valve. This allows motive pressure to enter the pump body, which drives the condensate thru the outlet check valve into the condensate return line. During the discharge cycle, the liquid level and the float inside the pump tank drop.

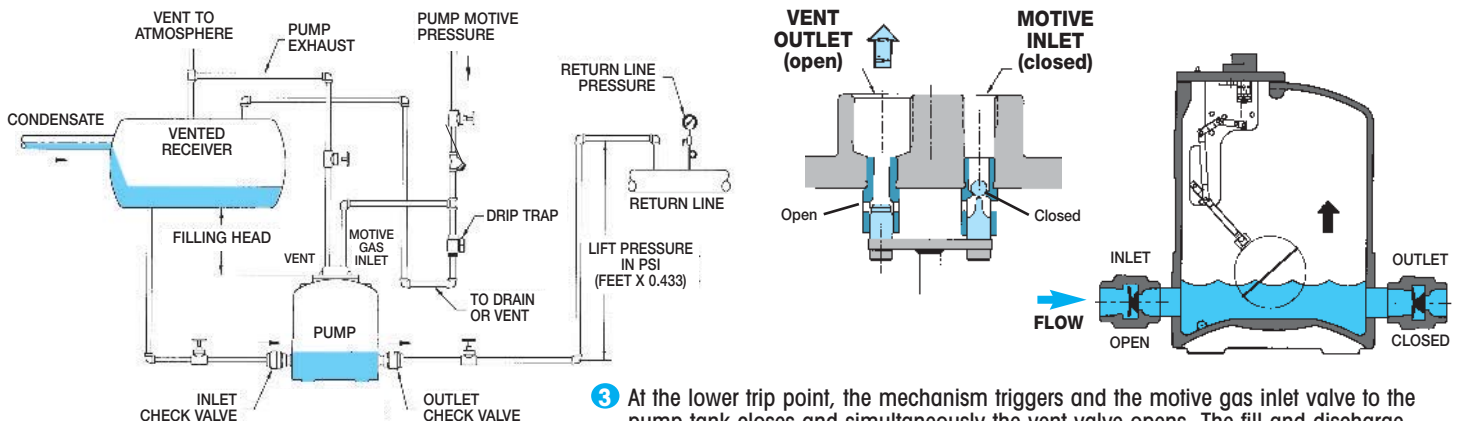

3 At the lower trip point, the mechanism triggers and the motive gas inlet valve to the pump tank closes and simultaneously the vent valve opens. The fill and discharge cycle then repeats itself.

NON-ELECTRIC CONDENSATE PUMPS

PMP Series

Pressure Motive Pump Internal Mechanism

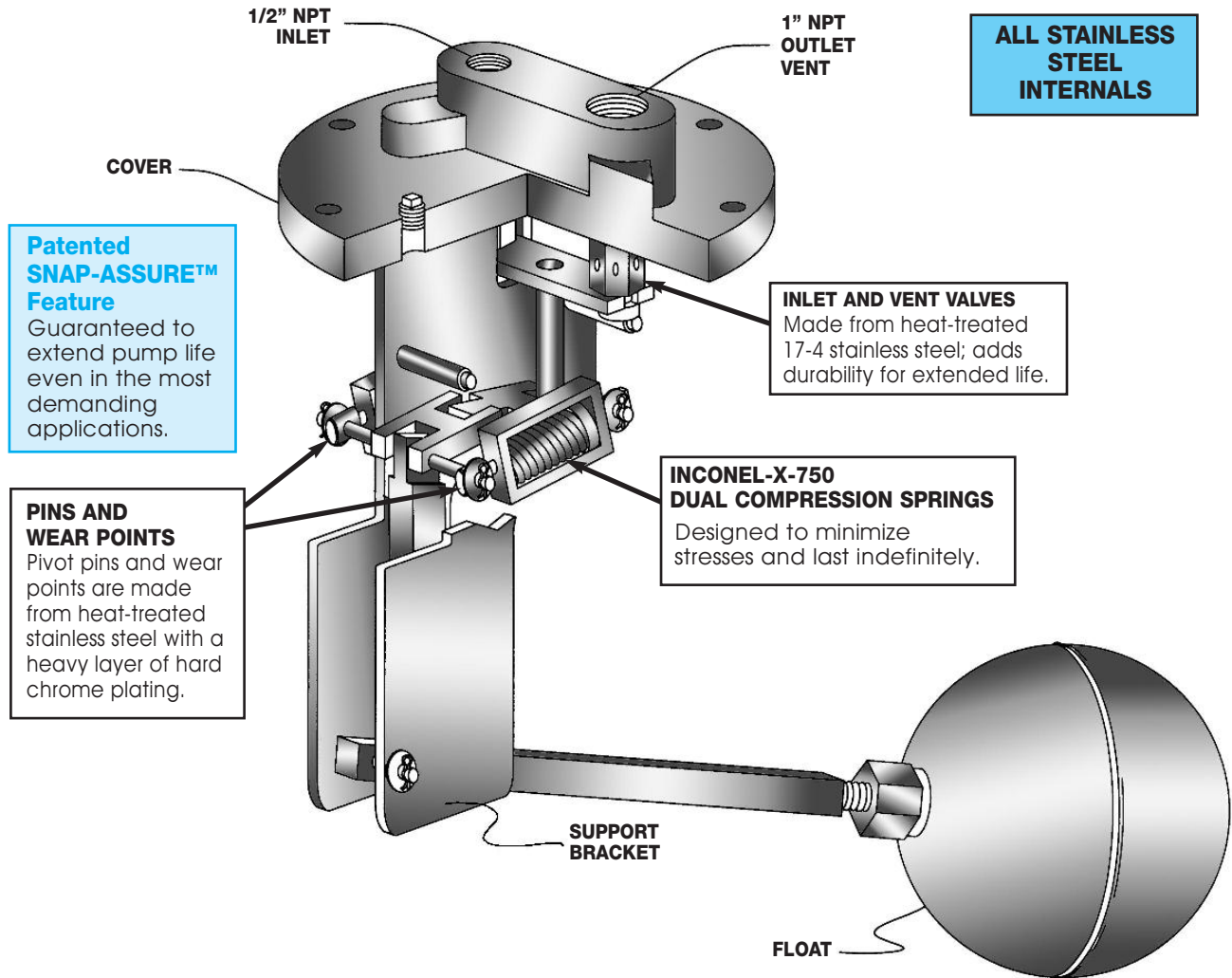

ALL STAINLESS STEEL INTERNALS

Patented SNAP-ASSURE™ Feature
Guaranteed to extend pump life even in the most demanding applications.

INLET AND VENT VALVES
Made from heat-treated 17-4 stainless steel; adds durability for extended life.

INCONEL-X-750 DUAL COMPRESSION SPRINGS
Designed to minimize stresses and last indefinitely.

PINS AND WEAR POINTS
Pivot pins and wear points are made from heat-treated stainless steel with a heavy layer of hard chrome plating.

INTERNAL MECHANISM FEATURES

- Equipped with our Patented “Snap-Assure” feature, found only on Watson McDaniel’s mechanisms. “Snap-Assure” extends the useful life of the pump by assuring that the internal toggle action triggers at every fill and discharge cycle
- All Stainless Steel components eliminate corrosion and rusting
- Hard chrome-plated pivot pins and wear points substantially reduce the rate of wear on critical components
- 17-4 heat-treated stainless steel inlet and vent valve (Hardened seats have proven themselves to last years longer in service)
- Dual compression springs made from Inconel-X-750 minimize stress and corrosion and are designed to last indefinitely
- Precision manufactured mechanisms never require field adjustments
- Watson McDaniel “Snap-Assure” mechanisms can be purchased separately and will fit other manufacturers’ pump tanks

INTERNAL MECHANISM MATERIALS

Cover	Material for cover same as tank material
Cover Gasket	Garlock / Grafoil
Cover Bolts	Grade B5
Inlet Valve	Hardened Stainless Steel, Rc 40
Vent Valve	Hardened Stainless Steel, Rc 40
Mechanism Yoke	304 Stainless Steel
Ball Float	Stainless Steel
Springs	Inconel-X-750
Other Internal Parts	Stainless Steel

Snap-Assure Patent No. 6572340

NON-ELECTRIC CONDENSATE PUMPS

PMPC CAST DUCTILE IRON TANK

Pressure Motive Pump

Watson McDaniel reserves the right to change the designs and/or materials of its products without notice.
©2010 Watson McDaniel Company

PUMPS

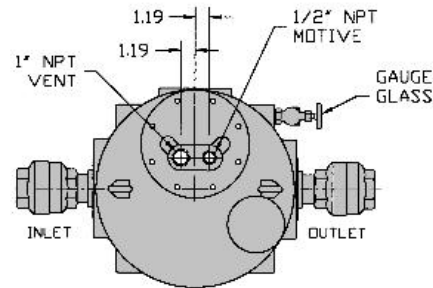

Model	PMPC
Body	Ductile Iron
Cover	Ductile Iron
Check Valves	Stainless Steel
PMO Max. Operating Pressure	200 PSIG
TMO Max. Operating Temperature	388°F
PMA Max. Allowable Pressure	200 PSIG @ 650°F
TMA Max. Allowable Temperature	650°F @ 200 PSIG

Note: ASME "UM" code stamp available.

TYPICAL APPLICATIONS

The PMPC pressure motive pump body & cover are manufactured from ductile iron. ASME "UM" code stamp is available. This pump is typically used when liquids must be moved to higher elevation, higher pressure or extended distances.

FEATURES

- Equipped with our Patented "Snap-Assure" Mechanism which extends the useful life of the pump
- Mechanism incorporates heat-treated stainless steel wear items
- All stainless steel internals for ultimate corrosion resistance
- Dual compression springs made from Inconel-X-750 for high-temperature corrosive service
- Operates using steam, air, nitrogen or other pressurized gases as the motive force
- Non-Electric – can be used in remote locations or NEMA 4, 7, 9 & hazardous areas

SAMPLE SPECIFICATION

The non-electric pressure powered pump shall be capable of operating with a maximum motive pressure of 200 PSIG provided by steam, air or other gas supply. The pump body shall be cast ASTM A-395 Ductile Iron capable of an ASME "UM" code stamp if requested. The pump mechanism shall be float operated with a patented "Snap-Assure" feature constructed of all stainless steel materials with all load bearing points hardened for extended service life. The mechanism shall feature two Inconel springs used in compression with motive & vent valves hardened to 40c Rockwell.

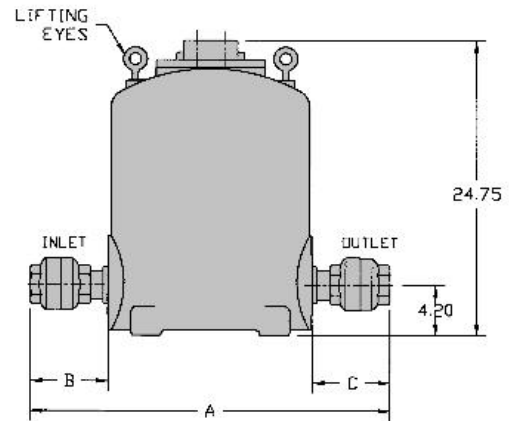

DIMENSIONS — inches / pounds

Size (Inlet x Outlet)	A	B	C	Weight (lbs)
1" x 1"	29 1/2	6	6	360
1 1/2" x 1"	30 3/4	7 1/2	6	365
1 1/2" x 1 1/2"	31 1/4	7 1/2	7 1/2	367
2" x 1"	31	8	6	370
2" x 1 1/2"	32 1/2	8	7 1/2	380
2" x 2"	32 3/4	8	8	385
3" x 2"	35 1/4	9 1/4	8	390

MATERIALS

Body & Cover	Ductile Iron
Cover Gasket	Grafoil
Cover Bolts	Steel
Inlet Valve	Hardened Stainless Steel 40 Rc
Vent Valve	Hardened Stainless Steel 40 Rc
Mechanism Yoke	304 Stainless Steel
Ball Float	304 Stainless Steel
Check Valves	Stainless Steel
Springs	Inconel-X-750
Other Internal Components	Stainless Steel

Snap-Assure Patent No. 6572340

NON-ELECTRIC CONDENSATE PUMPS

FABRICATED STEEL TANK **PMPF**

Pressure Motive Pump

PUMPS

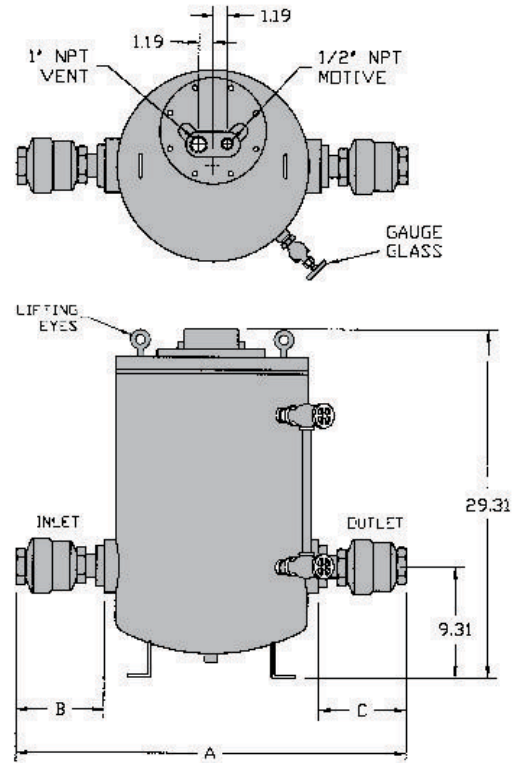

Model	PMPF
Body	Carbon Steel
Cover	Carbon Steel
Check Valves	Stainless Steel
PMO Max. Operating Pressure	200 PSIG
TMO Max. Operating Temperature	388°F
PMA Max. Allowable Pressure	250 PSIG @ 650°F

TYPICAL APPLICATIONS

The **PMPF** pressure motive pump body & cover are manufactured from carbon steel. These tanks are fabricated with 1/8" corrosion allowance and receive the **ASME "UM" code stamp**. This pump is typically used when liquids must be moved to higher elevation, higher pressure or extended distances.

FEATURES

- Equipped with our Patented "**Snap-Assure**" Mechanism which extends the useful life of the pump
- Mechanism incorporates heat-treated stainless steel wear items
- All stainless steel internals for ultimate corrosion resistance
- Dual compression springs made from **Inconel-X-750** for high-temperature corrosive service
- Operates using steam, air, nitrogen or other pressurized gases as the motive force
- **Non-Electric** – can be used in remote locations or **NEMA 4, 7, 9 & hazardous areas**

SAMPLE SPECIFICATION

The non-electric pressure powered pump shall be capable of operating with a maximum motive pressure of 200 PSIG provided by steam, air or other gas supply. The pump body shall be fabricated carbon steel and certified with the ASME "UM" code stamp. The pump mechanism shall be float operated with a patented "Snap-Assure" feature constructed of all stainless steel materials with all load bearing points hardened for extended service life. The mechanism shall feature two Inconel springs used in compression with motive & vent valves hardened to 40c Rockwell.

DIMENSIONS — inches / pounds				
Size (Inlet x Outlet)	A	B	C	Weight (lbs)
1" x 1"	30 ¹ / ₂	6	6	215
1 ¹ / ₂ " x 1"	31 ³ / ₄	7 ¹ / ₂	7 ¹ / ₂	220
1 ¹ / ₂ " x 1 ¹ / ₂ "	32 ¹ / ₄	7 ¹ / ₂	6	223
2" x 1"	32	8	6	225
2" x 1 ¹ / ₂ "	33 ¹ / ₂	8	7 ¹ / ₂	230
2" x 2"	33 ³ / ₄	8	8	235
3" x 2"	35 ¹ / ₄	9 ¹ / ₄	8	240

MATERIALS

Body & Cover	Carbon Steel
Cover Gasket	Grafoil
Cover Bolts	Steel
Inlet Valve	Hardened Stainless Steel 40 Rc
Vent Valve	Hardened Stainless Steel 40 Rc
Mechanism Yoke	304 Stainless Steel
Ball Float	304 Stainless Steel
Check Valves	Stainless Steel
Springs	Inconel-X-750
Other Internal Components	Stainless Steel

Snap-Assure Patent No. 6572340

NON-ELECTRIC CONDENSATE PUMPS

PMPSS STAINLESS STEEL TANK

Pressure Motive Pump

Watson McDaniel reserves the right to change the designs and/or materials of its products without notice.
©2010 Watson McDaniel Company

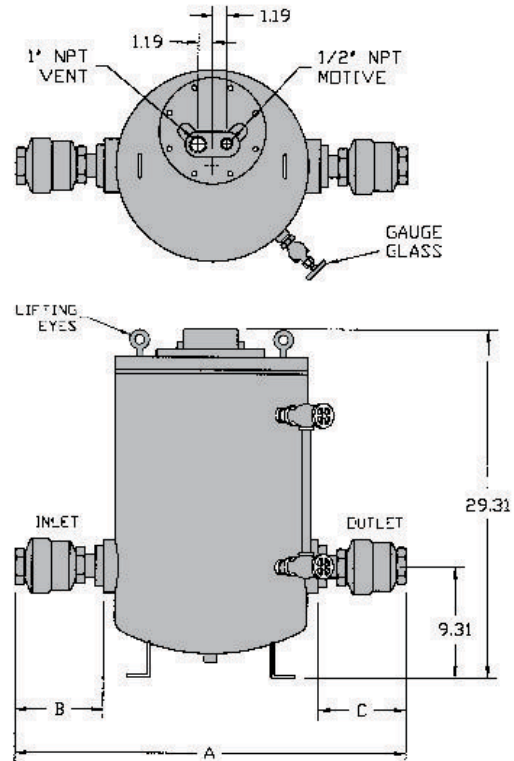

Model	PMPSS
Body	304L Stainless Steel *
Cover	Carbon Steel
Check Valves	Stainless Steel
PMO Max. Operating Pressure	150 PSIG
TMO Max. Operating Temperature	366 °F
PMA Max. Allowable Pressure	150 PSIG @ 650 °F

* For special 316L SS, consult factory.

TYPICAL APPLICATIONS

The **PMPSS** pressure motive pump body & cover are manufactured from **304L Stainless Steel**. These pumps receive the **ASME "UM" code stamp**. This pump is designed to be used in harsh and corrosive environments.

FEATURES

- Equipped with our **Patented "Snap-Assure" Mechanism** which extends the useful life of the pump
- Mechanism incorporates **heat-treated stainless steel wear items**
- All stainless steel internals for ultimate corrosion resistance
- Dual compression springs made from **Inconel-X-750** for high-temperature corrosive service
- Operates using steam, air, nitrogen or other pressurized gases as the motive force
- **Non-Electric** – can be used in remote locations or **NEMA 4, 7, 9 & hazardous areas**

SAMPLE SPECIFICATION

The non-electric pressure powered pump shall be capable of operating with a maximum motive pressure of 150 PSIG provided by steam, air or other gas supply. The pump body shall be 304L Stainless Steel and certified with the ASME "UM" code stamp. The pump mechanism shall be float operated with a patented "Snap-Assure" feature constructed of all stainless steel materials with all load bearing points hardened for extended service life. The mechanism shall feature two Inconel springs used in compression with motive & vent valves hardened to 40c Rockwell.

DIMENSIONS — inches / pounds

Size (Inlet x Outlet)	A	B	C	Weight (lbs)
1" x 1"	30 1/2	6	6	215
1 1/2" x 1"	31 3/4	7 1/2	7 1/2	220
1 1/2" x 1 1/2"	32 1/4	7 1/2	6	223
2" x 1"	32	8	6	225
2" x 1 1/2"	33 1/2	8	7 1/2	230
2" x 2"	33 3/4	8	8	235
3" x 2"	35 1/4	9 1/4	8	240

MATERIALS

Body & Cover	304L Stainless Steel
Cover Gasket	Grafoil
Cover Bolts	Steel
Inlet Valve	Hardened Stainless Steel 40 Rc
Vent Valve	Hardened Stainless Steel 40 Rc
Mechanism Yoke	304 Stainless Steel
Ball Float	304 Stainless Steel
Check Valves	Stainless Steel
Springs	Inconel-X-750
Other Internal Components	Stainless Steel

Snap-Assure Patent No. 6572340

NON-ELECTRIC CONDENSATE PUMPS

CARBON STEEL LOW-PROFILE TANK **PMPLS**

Pressure Motive Pump

PUMPS

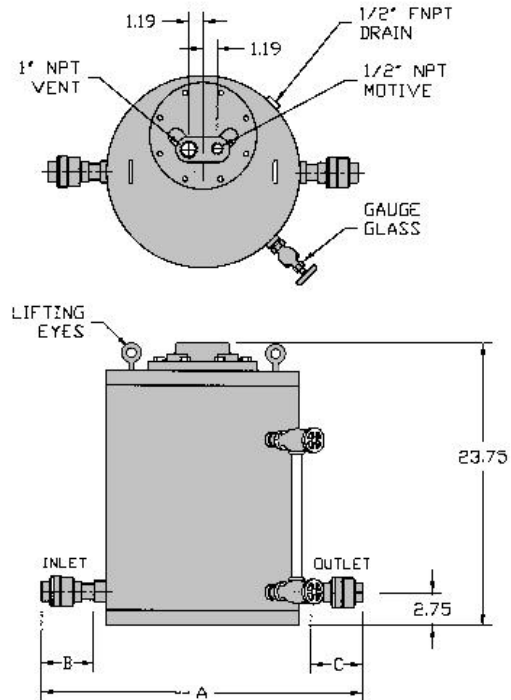

Model	PMPLS
Body	Carbon Steel
Cover	Carbon Steel
Check Valves	Stainless Steel
PMO Max. Operating Pressure	150 PSIG
TMO Max. Operating Temperature	366°F
PMA Max. Allowable Pressure	150 PSIG @ 650°F

Note: Optional 200 PSIG PMA/PMO. Consult Factory.

TYPICAL APPLICATIONS

The **PMPLS** pressure motive pump is a lower profile than the standard PMPF model and is sometimes required when draining condensate from process equipment that is positioned close to the ground which limits the filling head of the pump. Pump & body cover are manufactured from carbon steel and receive the **ASME "UM" code stamp**.

FEATURES

- Equipped with our Patented "Snap-Assure" Mechanism which extends the useful life of the pump
- Mechanism incorporates heat-treated stainless steel wear items
- All stainless steel internals for ultimate corrosion resistance
- Dual compression springs made from Inconel-X-750 for high-temperature corrosive service
- Operates using steam, air, nitrogen or other pressurized gases as the motive force
- Non-Electric – can be used in remote locations or NEMA 4, 7, 9 & hazardous areas

SAMPLE SPECIFICATION

The non-electric pressure powered pump shall be capable of operating with a maximum motive pressure of 150 PSIG provided by steam, air or other gas supply. The pump body shall be fabricated carbon steel and certified with the ASME "UM" code stamp. The pump mechanism shall be float operated with a patented "Snap-Assure" feature constructed of all stainless steel materials with all load bearing points hardened for extended service life. The mechanism shall feature two Inconel springs used in compression with motive & vent valves hardened to 40c Rockwell.

DIMENSIONS — inches / pounds				
Size (Inlet x Outlet)	A	B	C	Weight (lbs)
1" x 1"	29 ¹ / ₂	5 ⁵ / ₈	5 ⁵ / ₈	200
1 ¹ / ₂ " x 1"	30 ³ / ₄	7	5 ⁵ / ₈	205
1 ¹ / ₂ " x 1 ¹ / ₂ "	32 ¹ / ₈	7	7	210

MATERIALS	
Body & Cover	Carbon Steel
Cover Gasket	Grafoil
Cover Bolts	Steel
Inlet Valve	Hardened Stainless Steel 40 Rc
Vent Valve	Hardened Stainless Steel 40 Rc
Mechanism Yoke	304 Stainless Steel
Ball Float	304 Stainless Steel
Check Valves	Stainless Steel
Springs	Inconel-X-750
Other Internal Components	Stainless Steel

Snap-Assure Patent No. 6572340

NON-ELECTRIC CONDENSATE PUMPS

PMPM CAST IRON MINI-PUMP

Pressure Motive Pump

Watson McDaniel reserves the right to change the designs and/or materials of its products without notice.
©2010 Watson McDaniel Company

PUMPS

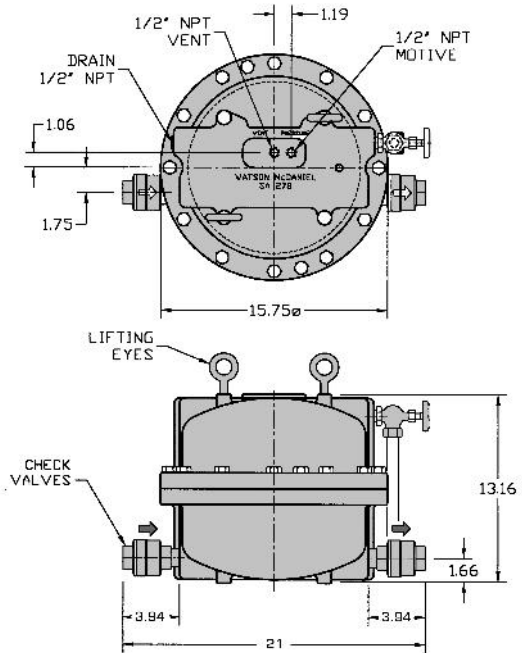
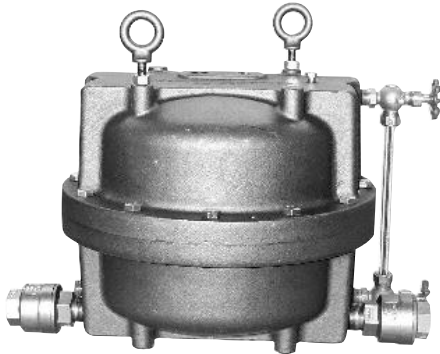

Model	PMPM
Body	Cast Iron
Cover	Cast Iron
Sizes	1", 1 1/4"
Check Valves	Stainless Steel
PMO Max. Operating Pressure	150 PSIG
TMO Max. Operating Temperature	366°F
PMA Max. Allowable Pressure	150 PSIG @ 450°F

TYPICAL APPLICATIONS

The Model **PMPM** pressure motive pump has an *extremely low profile*. These low-profile tanks are required when draining condensate from process equipment positioned close to the ground which limits the filling head of the pump.

FEATURES

- Mechanism incorporates **heat-treated stainless steel wear items** for extended service life
- All stainless steel internals for ultimate corrosion resistance
- Dual springs made from **Inconel-X-750** for high-temperature corrosive service
- Operates using steam, air, nitrogen or other pressurized gases as the motive force
- Low-profile design
- **Non-Electric** – can be used in remote locations or NEMA 4, 7, 9 & hazardous areas

MATERIALS

Body & Cover	Cast Iron
Cover Gasket	Garlock
Cover Bolts	Steel
Inlet Valve	Hardened Stainless Steel 40 Rc
Vent Valve	Hardened Stainless Steel 40 Rc
Mechanism Yoke	304 Stainless Steel
Ball Float	304 Stainless Steel
Check Valves	Stainless Steel
Springs	Inconel-X-750
Other Internal Components	Stainless Steel

CAPACITIES – Condensate (lbs/hr)

Motive Pressure (PSIG)	Back Pressure (PSIG)	6" Filling Head			
		Steam Motive		Air Motive	
		1"	1 1/4"	1"	1 1/4"
25	15	1200	1800	1720	2580
25	5	1970	2955	2265	3398
50	40	1200	1800	1640	2460
50	25	1480	2220	1980	2970
50	15	1860	2790	2220	3330
50	5	2240	3360	2485	3728
75	60	1160	1740	1935	2903
75	40	1640	2460	2185	3278
75	25	1960	2960	2340	3510
100	60	1415	2122	2020	3030
100	40	1825	2732	2280	3420
100	25	1985	2977	2420	3630
100	15	2175	3262	2455	3683
150	100	1120	1680	1456	2184
150	80	1220	1830	1525	2288
150	60	1570	2355	1885	2828

SIZING

The capacity of the **PMPM** is based on the inlet steam pressure, the system back pressure, and the amount of filling head available. The trap used in a pump-trap combination must be sized to handle the instantaneous discharge of the pump.

Choose a F&T trap that will pass the condensate load at a 1/4 PSI differential pressure. The PMO of the steam trap must be higher than the motive inlet steam pressure. Consult factory for proper choice of steam trap.

NON-ELECTRIC CONDENSATE PUMPS

CARBON STEEL HIGH-CAPACITY TANK **PMPBP** Pressure Motive Pump

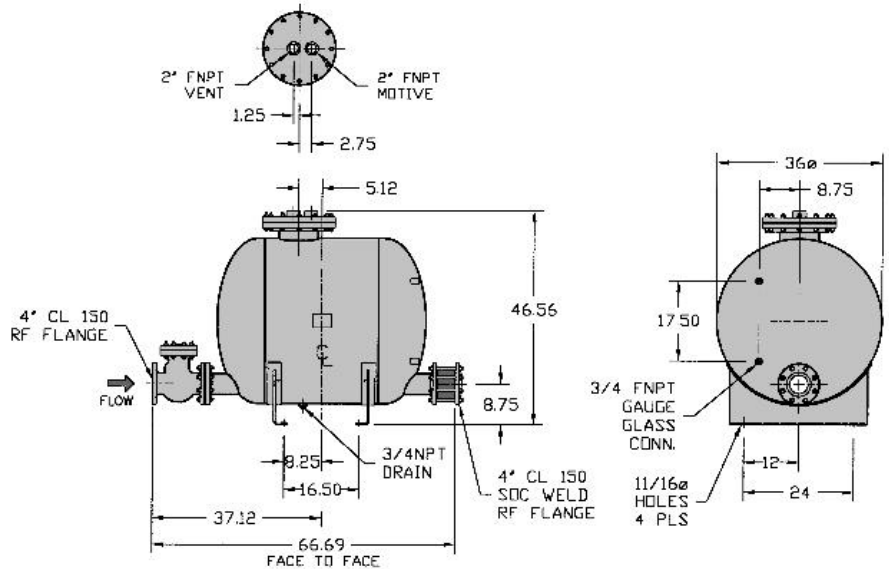

Model	PMPBP
Body	Carbon Steel
Cover	Carbon Steel
Check Valves	Stainless Steel & Steel
PMO Max. Operating Pressure	150 PSIG
TMO Max. Operating Temperature	366°F
PMA Max. Allowable Pressure	150 PSIG @ 470°F

MATERIALS

Body & Cover	Carbon Steel
Cover Gasket	Non-Asbestos
Cover Bolts	Steel
Inlet Valve	Stainless Steel
Vent Valve	Stainless Steel
Mechanism Yoke	304 Stainless Steel
Ball Float	304 Stainless Steel
Check Valves	Stainless Steel & Steel
Springs	Stainless Steel
Other Internal Components	Stainless Steel

TYPICAL APPLICATIONS

The **PMPBP** is an *extremely high-capacity* pressure motive pump for applications requiring large transfer of condensate or other liquids. The internal operating mechanism functions identically to other pumps in the PMP series. **ASME "U" code stamp is available.**

FEATURES

- All stainless steel internals for ultimate corrosion resistance
- Operates using steam, air, nitrogen or other pressurized gases as the motive force
- **Non-Electric** – can be used in remote locations or **NEMA 4, 7, 9 & hazardous areas**

OPTIONS

- Cycle counter for measuring the amount of condensate flow through the pump.
- Insulation jackets are available to stop heat losses through the pump body.
- Sight glass for monitoring liquid level inside pump body.

NON-ELECTRIC CONDENSATE PUMPS

PMPSP "The Pit Boss"

Watson McDaniel reserves the right to change the designs and/or materials of its products without notice.
©2010 Watson McDaniel Company

Sump Drainer

PUMPS

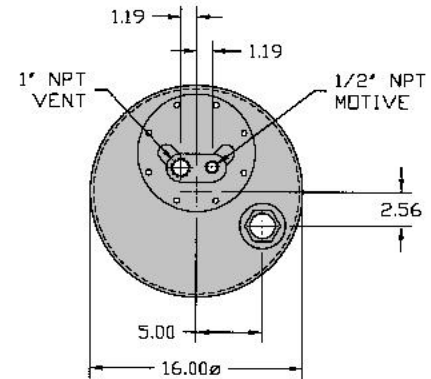

Model	PMPSP
Body	Carbon Steel
Cover	Ductile Iron
Check Valves	Stainless Steel
PMO Max. Operating Pressure	150 PSIG
TMO Max. Operating Temperature	366°F
PMA Max. Allowable Pressure	150 PSIG @ 650°F

Connection Sizes NPT	
Inlet	Outlet
1 1/2"	1 1/2"
2"	2"
3"	2"

TYPICAL APPLICATIONS

The **PMPSP** Sump Drainer uses the identical internal mechanism as the standard PMP models. The piping configuration is such that the liquid is discharged vertically upwards as opposed to horizontally out the side. This allows the unit to be easily positioned inside of a sump area. Condensate or water from the sump enters the tank through a stainless steel low resistance check valve.

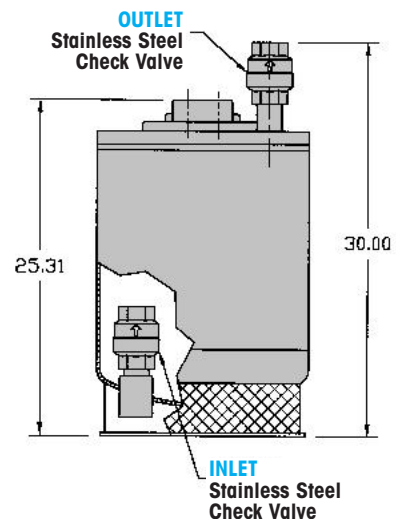

FEATURES

- Equipped with our Patented "Snap-Assure" Mechanism which extends the useful life of the pump
- Mechanism incorporates heat-treated stainless steel wear items
- All stainless steel internals for ultimate corrosion resistance
- Dual compression springs made from Inconel-X-750 for high-temperature corrosive service
- Operates using steam, air, nitrogen or other pressurized gases as the motive force
- **Non-Electric** – can be used in remote locations or NEMA 4, 7, 9 & hazardous areas
- Built-in strainer screen

NON-ELECTRIC CONDENSATE PUMPS

PMPSP

Sump Drainer

PUMPS

“The Pit Boss”

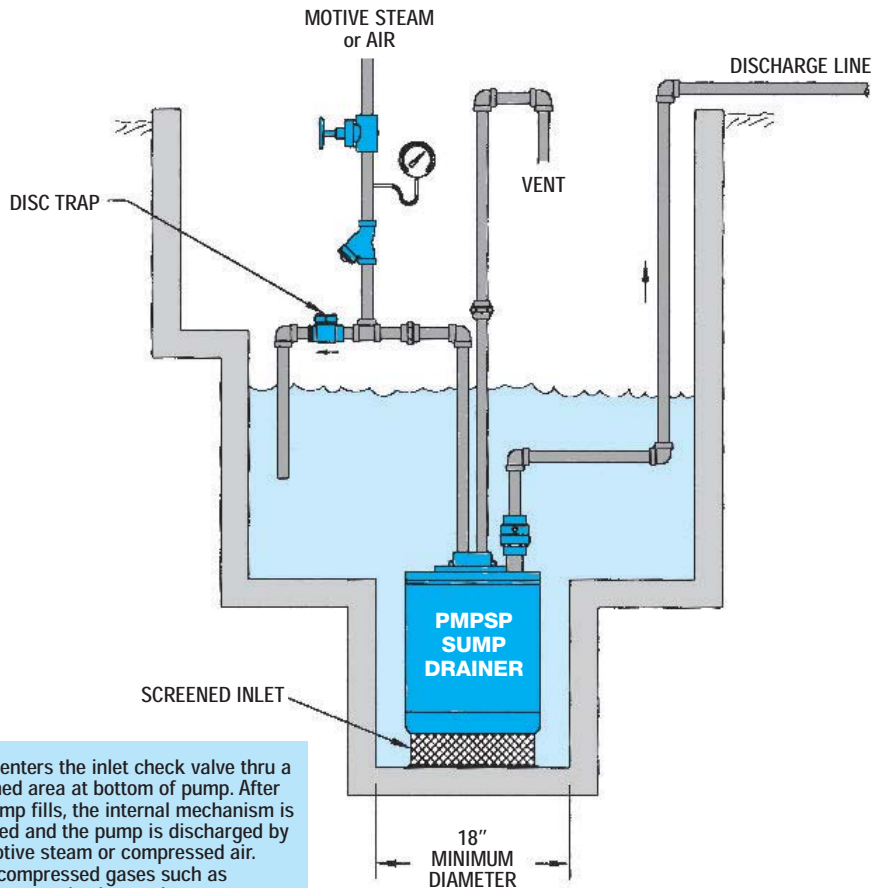

Water enters the inlet check valve thru a screened area at bottom of pump. After the pump fills, the internal mechanism is actuated and the pump is discharged by the motive steam or compressed air. Other compressed gases such as nitrogen can also be used.

CAPACITIES – Water (GPM) for 1 1/2" x 1 1/2" Size								
Motive Pressure (PSIG)	Capacity Correction Factors		Back Pressure (PSIG)					
	2" x 2"	3" x 2"	0	10	20	40	70	100
10	2.5	3	11.7					
20	1.8	2.4	12.5	9.2				
40	1.9	2.4	13.1	10.4	8.7			
70	1.7	2.4	12.9	11.0	9.4	7.1		
100	1.6	2	12.3	10.6	9.4	7.5	5.4	
125	1.6	2	11.6	10.1	9.0	7.5	5.6	4.3
150	1.6	2	10.7	9.5	8.8	7.2	5.7	4.5

Note: Capacities in above chart are for the 1-1/2" x 1-1/2" model. To determine capacities for the 2" x 2" & 3" x 2" models, multiply capacity in chart by appropriate correction factor.

Snap-Assure Patent No. 6572340

NON-ELECTRIC CONDENSATE PUMPS

Pumps with Receiver Tanks

Pressure Motive Pumps

PUMPS

Standard Skid Mounted Systems

FEATURES

- Easy to install with only four connections to be made in the field
- Dramatically reduces installation costs with all system elements pre-piped
- Utilizing Watson McDaniel's years of experience will ensure that vented receivers or pressurized reservoirs are properly sized for optimum system performance
- Watson McDaniel's fully-qualified fabrication facility is ASME code certified. Our engineers can design and build complete custom systems to meet all your requirements

TYPICAL OPTIONS

- Gauge glass assembly
- Cycle counter
- Insulation covers
- Motive steam drip trap
- Overflow pipe connection
- Pressure regulator for motive supply line

SIMPLEX SYSTEMS – Models PMPC & PMPF

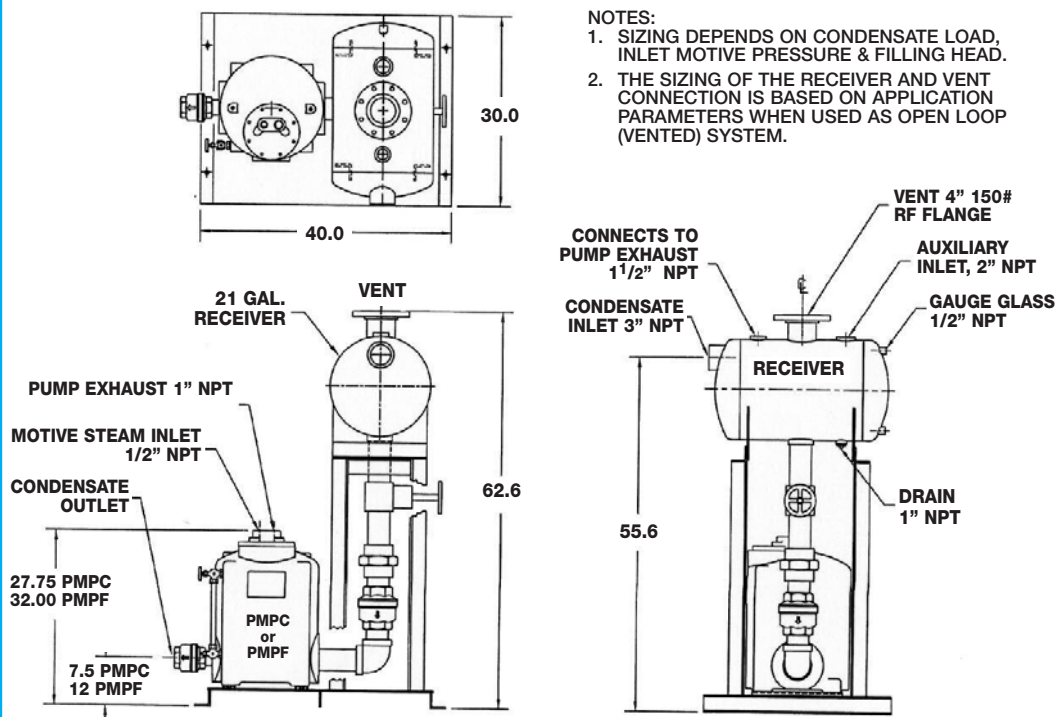

NOTES:

1. SIZING DEPENDS ON CONDENSATE LOAD, INLET MOTIVE PRESSURE & FILLING HEAD.
2. THE SIZING OF THE RECEIVER AND VENT CONNECTION IS BASED ON APPLICATION PARAMETERS WHEN USED AS OPEN LOOP (VENTED) SYSTEM.

DUPLEX SYSTEMS – Models PMPC & PMPF

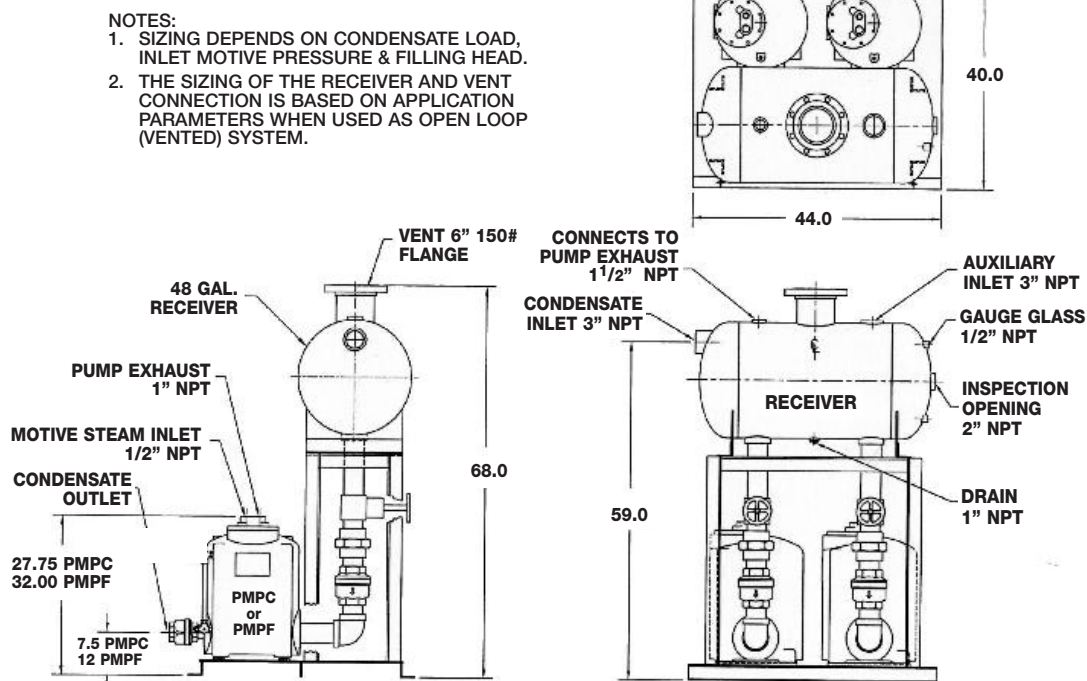

NOTES:

1. SIZING DEPENDS ON CONDENSATE LOAD, INLET MOTIVE PRESSURE & FILLING HEAD.
2. THE SIZING OF THE RECEIVER AND VENT CONNECTION IS BASED ON APPLICATION PARAMETERS WHEN USED AS OPEN LOOP (VENTED) SYSTEM.

NON-ELECTRIC CONDENSATE PUMPS

Pumps with Receiver Tanks

Pressure Motive Pumps

PUMPS

TRIPLEX SYSTEMS – Models PMPC & PMPF

- NOTES:
1. SIZING DEPENDS ON CONDENSATE LOAD, INLET MOTIVE PRESSURE & FILLING HEAD.
 2. THE SIZING OF THE RECEIVER AND VENT CONNECTION IS BASED ON APPLICATION PARAMETERS WHEN USED AS OPEN LOOP (VENTED) SYSTEM.

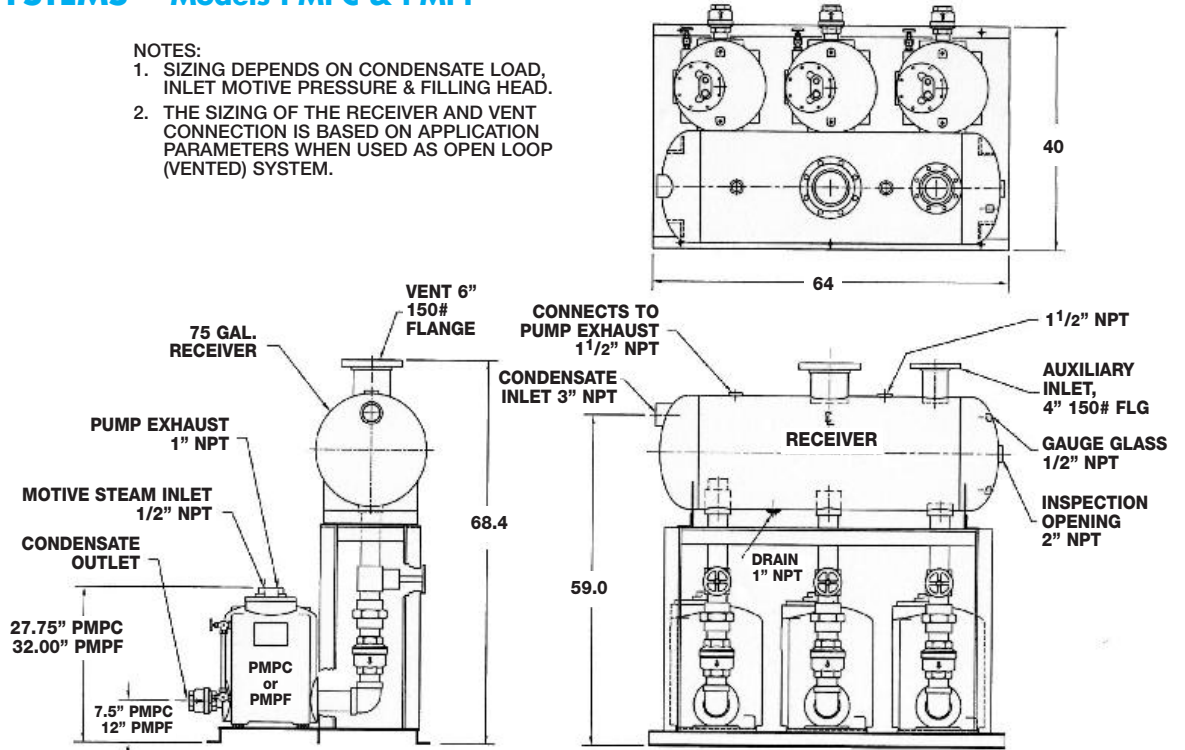

QUADRAPLEX SYSTEMS – Models PMPC & PMPF

- NOTES:
1. SIZING DEPENDS ON CONDENSATE LOAD, INLET MOTIVE PRESSURE & FILLING HEAD.
 2. THE SIZING OF THE RECEIVER AND VENT CONNECTION IS BASED ON APPLICATION PARAMETERS WHEN USED AS OPEN LOOP (VENTED) SYSTEM.

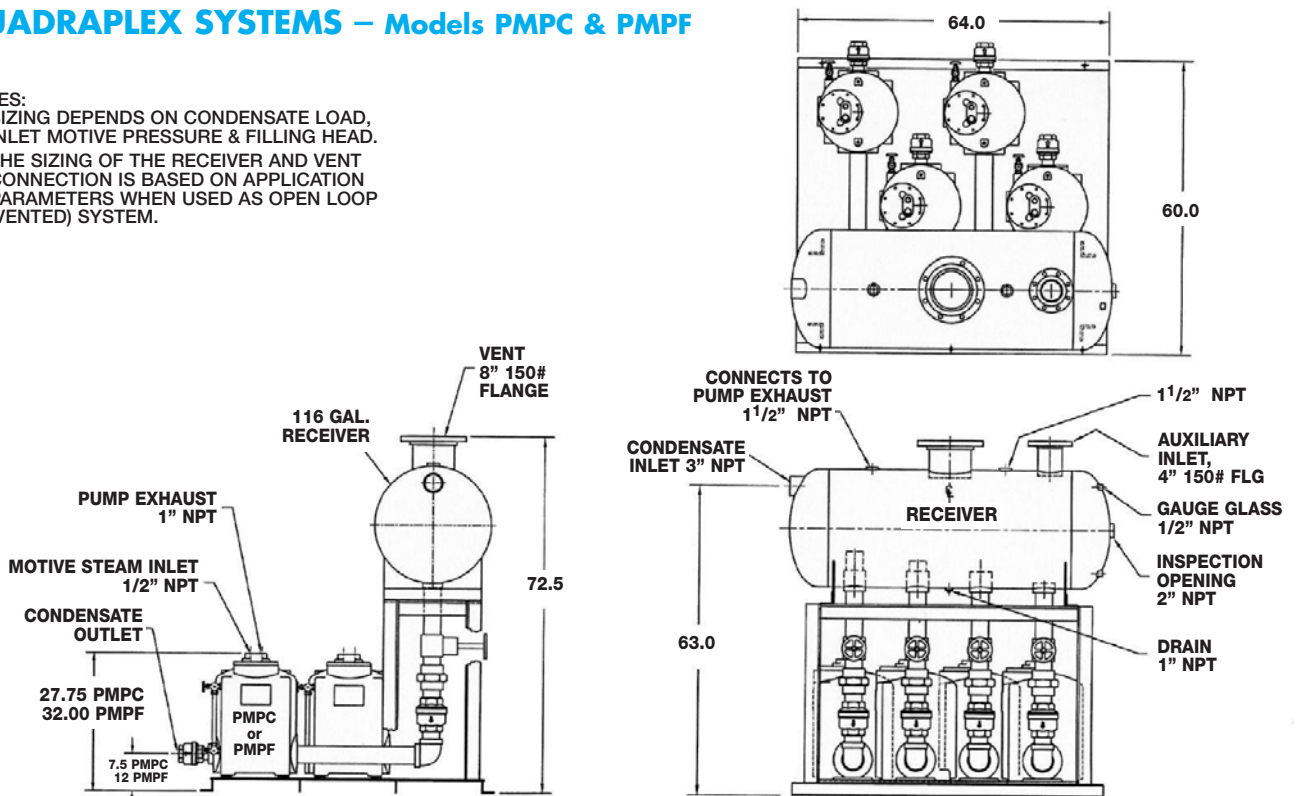

Pump & Trap Combinations

Watson McDaniel reserves the right to change the designs and/or materials of its products without notice.
©2010 Watson McDaniel Company

Why use a Pump-Trap?

A **Pump-Trap Combination** is used when draining condensate from a single piece of heat transfer equipment whose steam flow is being controlled with a modulating type valve. When a modulating valve controls the flow of steam to a heat exchanger, a stall condition can develop. Stall occurs when the modulating valve closes and steam pressure downstream of the valve is unable to push the condensate into the return line and it backs up into the heat exchanger. A Pump-Trap combination will eliminate this problem.

Pump-Traps with either **Internal** or **External** Steam Trap designs are available to suit individual application requirements.

Pump with Internal Steam Trap



PMPT

The Model **PMPT** low-profile pressure motive pump has an internal Steam Trap for applications requiring compact design due to spatial constraints. It is an excellent choice for drainage of various modulating process equipment.

Pump with External Steam Trap



WPT

The **WPT** Series are stand-alone pump units with an appropriately sized Steam Trap preassembled at the factory and mounted on a common base plate, allowing for simple installation. Pump-trap combos with an external trap are suitable when capacity requirements exceed internal steam trap designs. Available in several sizes and capacities.

The Pump-Trap Combination allows condensate discharge under all operating conditions of modulating equipment, including vacuum.

NON-ELECTRIC CONDENSATE PUMPS

PMPT & WPT

Pressure Motive Pump & Trap Combinations

Problem: Stalled Heat Exchanger

DESCRIPTION:

STALL CONDITION WITH MODULATED STEAM FLOW

When a modulating valve is used to control product temperature in heat transfer equipment, the valve will open and close as necessary to meet the variable demand of the system to maintain the product at constant temperature. Therefore, when maximum heating is required, the supply valve will be fully open to satisfy the high steam demand requirement. At this point, pressure is also being supplied at its highest level, which may be sufficient to overcome total system back pressure.

As the product temperature is satisfied, demand decreases and the valve correspondingly begins to close, reducing pressure differential. If demand is satisfied, the valve modulates to its fully closed position. Inlet supply pressure will eventually fall below system back pressure, resulting in system stall. This leads to poor heat transfer and water hammer as condensate backs up in the heat transfer equipment.

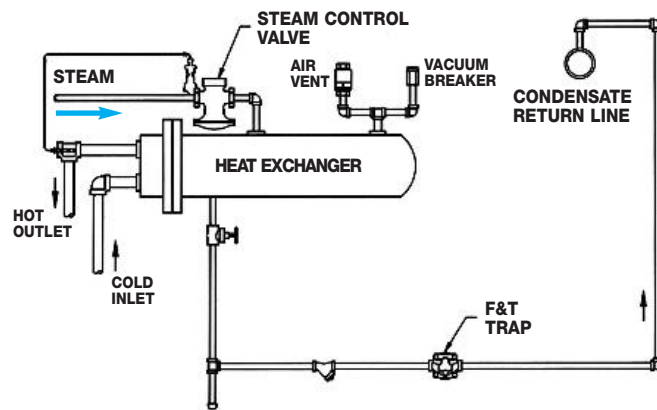

Heat Exchanger System without PMP

Solution: Use PMP & Steam Trap Combination

DESCRIPTION:

USE A PRESSURE MOTIVE PUMP AND STEAM TRAP COMBINATION

(Available in INTERNAL and EXTERNAL Steam Trap designs)

When the supply valve is fully open and inlet pressure exceeds back pressure, condensate forming in the heat transfer equipment will be pushed through the pump and steam trap into the condensate return line. As the supply valve begins to close and the back pressure exceeds inlet pressure, any condensate forming inside the heat transfer equipment will drain by gravity into the pump tank. The condensate will accumulate in the pump tank until the float mechanism reaches its trip point. The "tripping" of the mechanism opens the motive valve to allow high pressure steam into the tank to drive the condensate from the tank to the condensate return line.

Note: A larger steam trap than normally required to drain the heat transfer equipment must be used to handle the high instantaneous discharge rate of the pump. See additional information in this catalog for sizing guidelines.

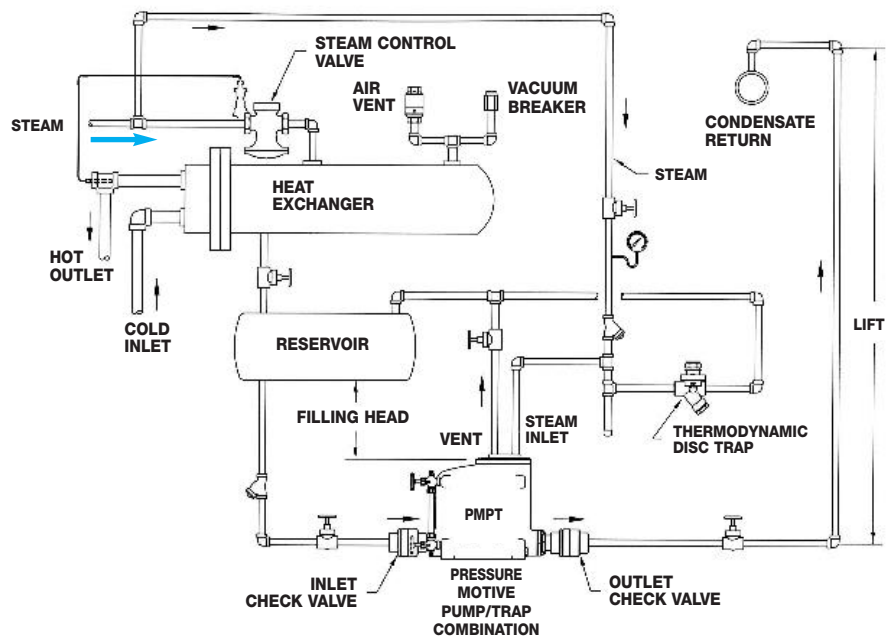

Heat Exchanger System with PMP & Internal Trap (PMPT) (Closed Loop System)

NON-ELECTRIC CONDENSATE PUMPS

PMPT

Watson McDaniel reserves the right to change the designs and/or materials of its products without notice.
©2010 Watson McDaniel Company

Pressure Motive Pump & Trap Combination (Internal Trap)

PUMPS

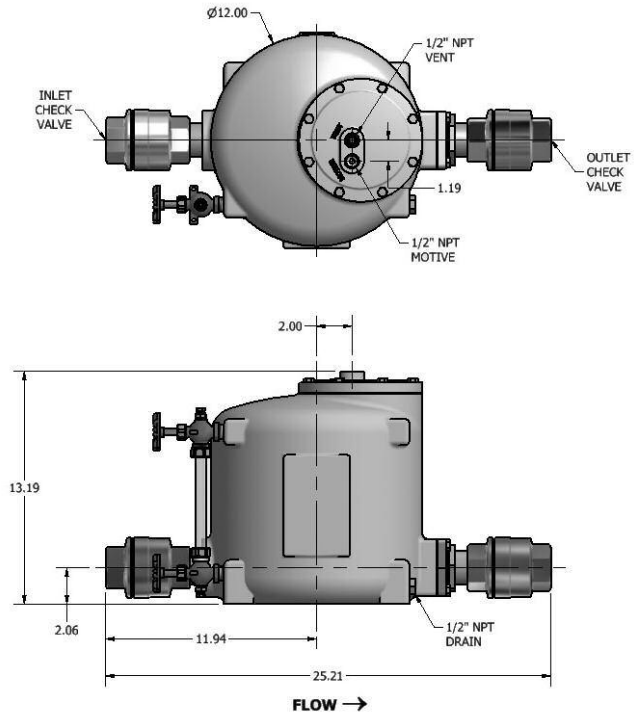

Model	PMPT
Body	Ductile Iron
Cover	Stainless Steel
Sizes	1", 1 1/2"
Check Valves	Stainless Steel
PMO Max. Operating Pressure	125 PSIG
TMO Max. Operating Temperature	366°F
PMA Max. Allowable Pressure	150 PSIG @ 450°F

TYPICAL APPLICATIONS

The Model **PMPT** low-profile pressure motive pump has an internal Steam Trap for applications requiring compact design due to spatial constraints. It is an excellent choice for drainage of various modulating process equipment.

The **PMPT** allows condensate discharge under all operating conditions of modulating equipment, including vacuum.

FEATURES

- Compact, low-profile design allows for drainage of equipment positioned close to the floor
- The **PMPT** provides provides condensate drainage for modulating equipment, preventing inefficient and dangerous system stall
- Equipped with our proven, Patented "Snap-Assure" mechanism which extends the useful life of the pump
- Internal mechanism can be removed from the top of the pump while pump remains piped in line
- Mechanism incorporates heat-treated stainless steel wear items
- Dual compression springs made from Inconel-X-750 for high-temperature, corrosive service

MATERIALS

Body	Ductile Iron SA-395
Cover	Stainless Steel CF8
Cover Gasket	Garlock
Cover Bolts	Steel
Inlet Valve	Hardened Stainless Steel 40 Rc
Vent Valve	Hardened Stainless Steel 40 Rc
Ball Float	300 Stainless Steel
Check Valves	Stainless Steel 316SS CF3
Springs	Inconel-X-750
Other Internal Components	Stainless Steel

OPTIONS

- Horizontal pipe reservoir (recommended)
- Motive and vent piping
- Motive piping components such as steam trap, strainer and regulator
- Packaged systems available with reservoir, base and skid
- ASME Code Stamp available upon request

Patent Pending

NON-ELECTRIC CONDENSATE PUMPS

PMPT

Pressure Motive Pump & Trap Combination (Internal Trap)

Capacity Operating in Pump Mode

CAPACITIES – Condensate (lbs/hr) Using steam as a motive pressure			
Motive Pressure (PSIG)	Total Back Pressure (PSIG)	Check Valve Size	
		1" x 1" 6" Head	1 1/2" x 1 1/2" 6" Head
5	2	150	258
10	5	302	523
10	2	409	704
25	15	791	1380
25	10	1020	1780
25	5	1224	2110
50	40	839	1470
50	25	1012	1770
50	10	1318	2280
75	60	810	1420
75	40	1122	1970
75	15	1241	2150
100	80	490	859
100	60	969	1700
100	40	1209	2100
100	15	1318	2260
125	115	146	256
125	100	371	649
125	80	634	1110
125	60	961	1680
125	40	1054	1830
125	15	1046	1780

Capacity Operating in Trap Mode

TRAP CAPACITIES	
Differential Pressure (PSI)	Capacity - Condensate (lbs/hr)
5	3470
10	4126
20	4907
30	5430
40	5835
50	6170
65	6588
75	6828
100	7337
125	7758

NON-ELECTRIC CONDENSATE PUMPS

WPT Series

Pressure Motive Pump & Trap
Combination (External Trap)

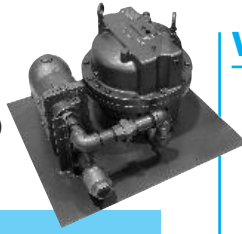

PUMPS

WPT Series Pump-Trap Combinations simplify Selection & Installation of Pressure Motive Pumps

- 5 size ranges available
- Up to 13,000 lbs/hr of condensate load

TYPICAL APPLICATIONS

The Watson McDaniel **WPT Pump-Trap Combinations** are excellent for draining heat exchangers or other equipment that is being fed by a temperature regulator or a temperature control valve. In these applications, the steam pressure in the heat exchanger may not be sufficient to overcome the back pressure in the condensate return line. When this condition occurs, the pressure powered pump takes over and uses high pressure steam supplied to the pump to discharge the condensate through the trap. When sufficient pressure does exist, the system functions like a standard steam trap.

PUMP-TRAP FEATURES

- Pump and Steam Trap are pre-mounted together on a single base for easy installation
- Engineering and selection is simplified

NOTE: Reservoir - The majority of Pump-Trap Combination applications require a reservoir above the pump to accommodate any condensate back-up during the discharge cycle of the pump. Consult Reservoir Sizing Guidelines or contact factory for additional information.

WPT1 - 1" x 1" (PMPM with 1 1/2" FTE-200)

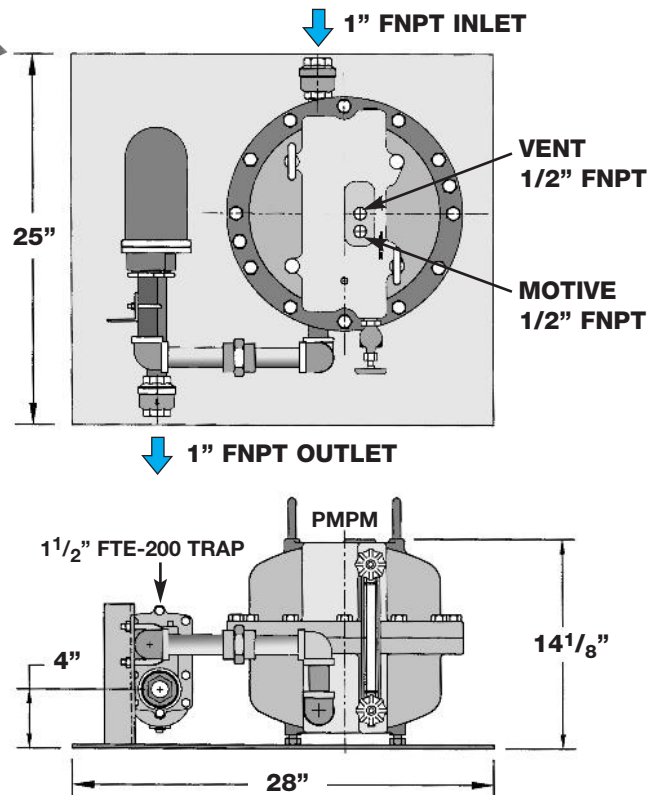

CAPACITIES – Condensate (lbs/hr) Using steam as a motive pressure

Motive Pressure (PSIG)	Total Back Pressure (PSIG)	WPT1	WPT2	WPT3	WPT4	WPT5
		1" x 1" 6" Head	1 1/4" x 1 1/4" 6" Head	1 1/2" x 1 1/2" 12" Head	2" x 2" 12" Head	3" x 2" 12" Head
5	2	185	335	1310	2320	4270
10	5	370	648	1760	3740	6230
10	2	502	898	2350	5640	9450
25	15	958	1590	2700	4690	7230
25	10	1240	2090	3020	5970	9370
25	5	1490	2570	3780	6850	11400
50	40	1010	1610	2090	3410	5040
50	25	1220	1970	3620	6650	10200
50	10	1600	2680	4080	7140	11500
75	60	993	1560	2250	3730	5660
75	40	1380	2190	3470	6010	8770
75	15	1550	2580	4390	7920	12400
100	80	612	951	2620	4390	6140
100	60	1210	1900	3390	5780	8120
100	40	1540	2440	4310	6940	10000
100	15	1720	2840	4620	8000	12300
125	115	195	301	2280	3490	4440
125	100	488	753	2880	4420	5720
125	80	836	1300	3520	5700	7630
125	60	1280	2000	4110	6880	9390
125	40	1420	2270	4910	7800	11100
125	15	1470	2440	5120	8420	12900
150	120	588	904	2560	3640	5100
150	100	977	1510	3020	4610	6270
150	80	1060	1640	3630	5780	8140
150	60	1340	2100	4230	6910	9920
150	40	1420	2260	4830	7930	11700
150	15	1450	2390	5230	8590	13300

Consult factory for motive pressures up to 200 PSIG

NON-ELECTRIC CONDENSATE PUMPS

WPT2 - 1 1/4" x 1 1/4" (PMPM with 2" FTE-200)

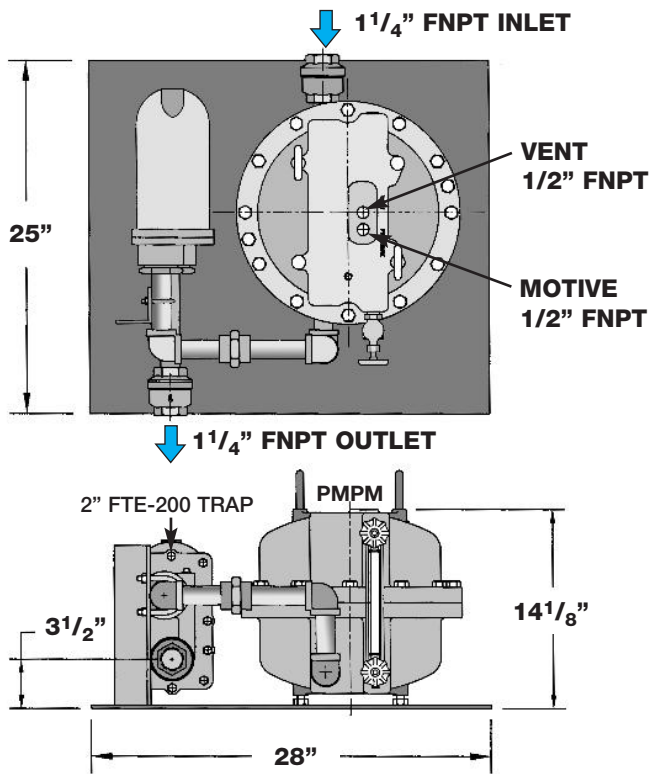

WPT3 - 1 1/2" x 1 1/2" (PMPLS with 2" FTE-200)

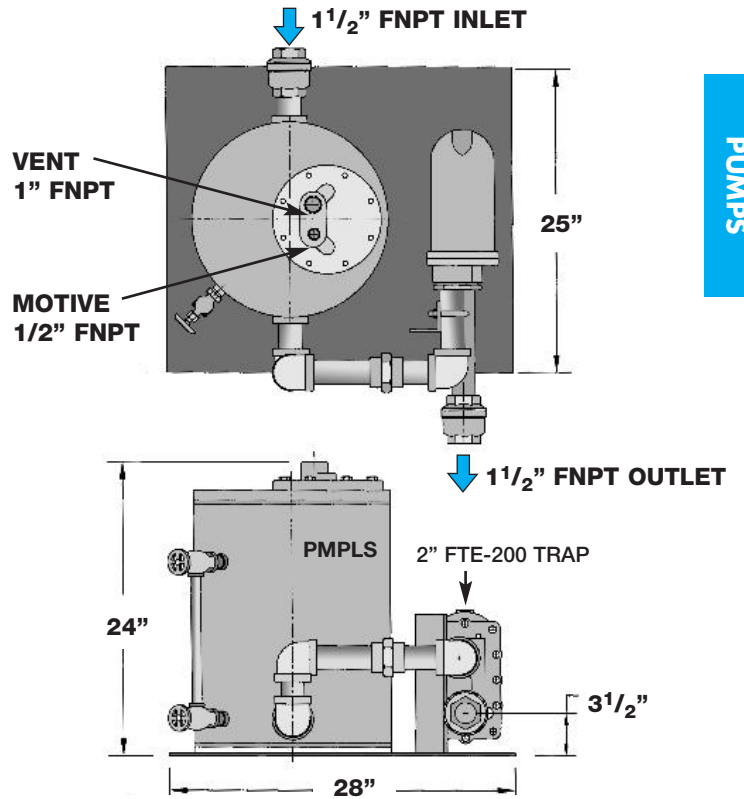

WPT4 - 2" x 2" (PMPC with 2" FTE-200)

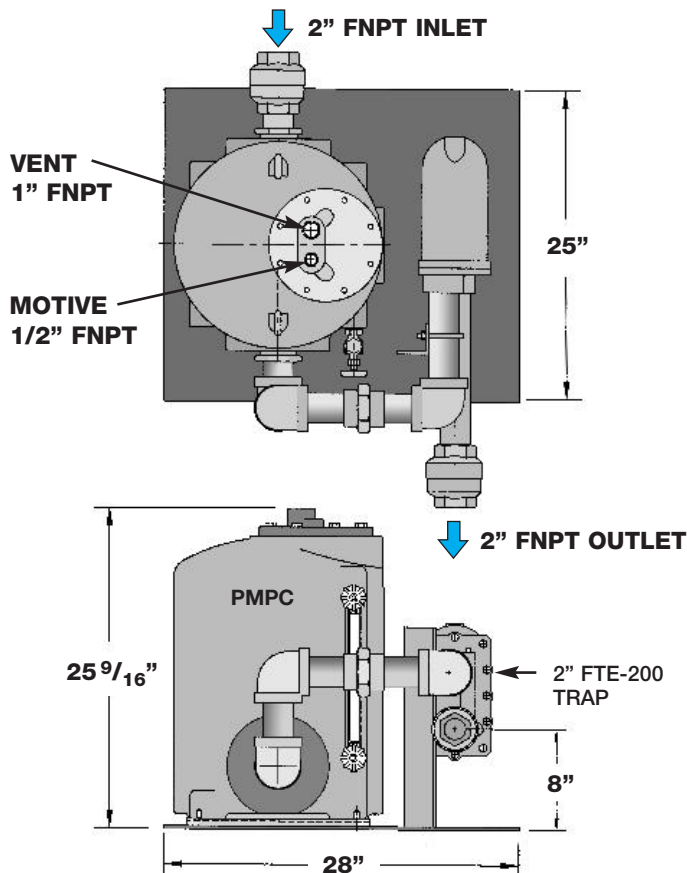

WPT5 - 3" x 2" (PMPC with 2 1/2" FTE-200)

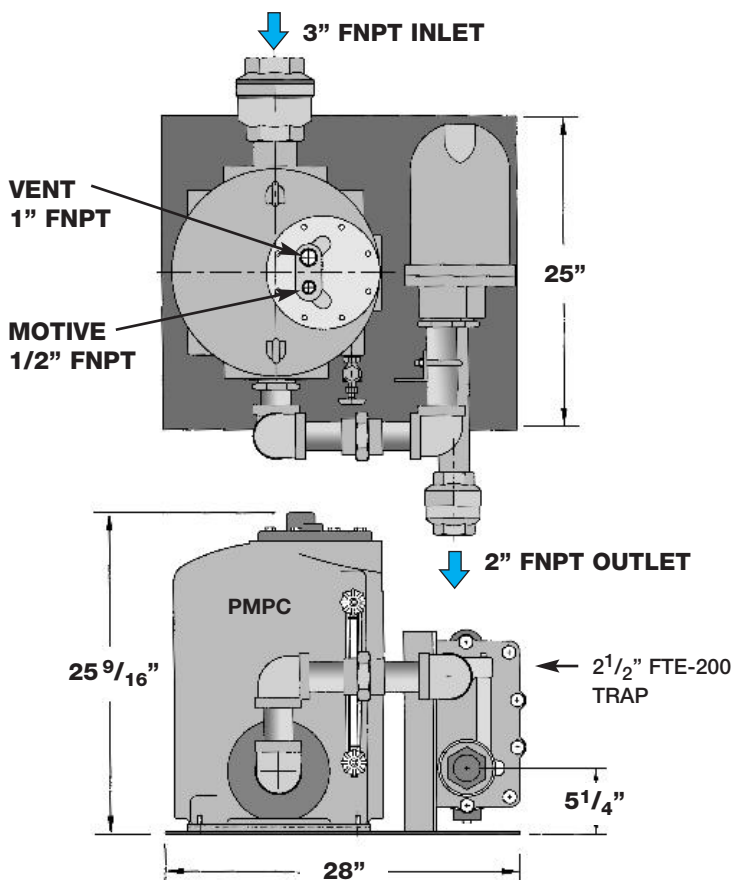

PUMPS

NON-ELECTRIC CONDENSATE PUMPS

Accessories & Options

Watson McDaniel reserves the right to change the designs and/or materials of its products without notice.
©2010 Watson McDaniel Company

Pressure Motive Pumps

PUMPS

Receiver Tanks

Four standard condensate receiver sizes are available for our Pressure Motive Pump Systems: 21, 48, 75 and 116 gallons. Custom Receiver fabrication is available with our **ASME** certified fabrication facility.

Gauge Glass

Pump Tanks are available with **gauge glass** to show condensate level inside the tank. (**bronze** or **stainless steel** retainer)

Cycle Counter

- The **cycle counter option** allows you to calculate and measure condensate flow through the pump on **vented systems**. This also gives an indication when maintenance and repairs to your mechanism may be required.
- Proper selection of the appropriate cycle counter is required: consult factory.
- The low-differential pressure cycle counter must be selected for applications where total pump back pressure is below 15 PSIG.
- Special cycle counter required when used on Closed Loop Systems.

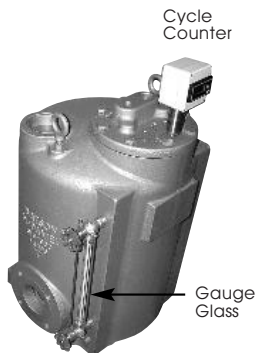

Pre-Piped PRV & Drip Leg

A fully-assembled Pre-piped PRV, Drip Leg, or PRV and Drip Leg Assembly **guarantees proper installation** of your PMP System. It assures that your skid package performs to optimum levels.

Vertical Discharge Pump

Vertical Discharge Pump with **"T-Bone"** connection allows inlet and outlet condensate **hook-ups to be made above the pump**. This is an advantage when space is limited around the base of the pump due to equipment or piping obstructions.

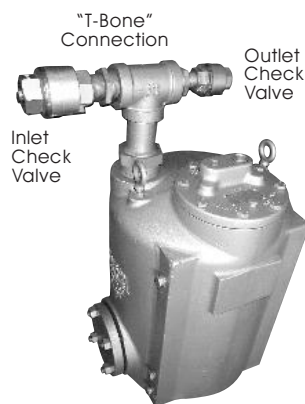

Product Description	Model Code
GAUGE GLASS:	
Standard Bronze	
for PMPC, PMPF, PMPLS, 21 Gallon Receiver	Gauge Glass 1
for PMPT	Gauge Glass PMPT
for PMPM Mini Pump (extremely low profile)	Gauge Glass PMPM
for 48 Gallon Receiver	Gauge Glass 1
for 75 Gallon Receiver	Gauge Glass 1
for 116 Gallon Receiver	Gauge Glass 1
Stainless Steel	
for PMPSS	Gauge Glass SS
Following Options are available for gauge glasses. Contact factory.	
Auto Drain (self-drain) Stainless Steel Armored	Gauge Glass 1A
Reflex Gauge for PMPC, PMPF, PMPLS, 21 Gallon Receiver	Gauge Glass - 1HP
CYCLE COUNTER:	
Digital Cycle Counter (fits all PMPs)	Specify open or closed system
Low Pressure Cycle Counter (fits all PMPs)	
ASME Code Stamp:	for PMPC, PMPT & PMPBP Pump Tank (Contact Factory)
	(Standard on 21, 48, 75, 116 Gallon Receivers and PMPF, PMPLS, PMPSS pump tanks)
INSULATION JACKET:	
for PMPC Ductile Iron Pump	INSUL-CRV-PMPC
for PMPF Fabricated Steel Pump	INSUL-CRV-PMPF
for PMPLS Low Profile Pump	INSUL-CRV-PMPLS
for PMPBP High Capacity Pump	INSUL-CRV-PMPBP
for PMPT Pump-Trap	INSUL-CRV-PMPT
for PMPM Mini Pump (extremely low profile)	INSUL-CRV-PMPM
for 21 Gallon Receiver	INSUL-CRV-21
for 48 Gallon Receiver	INSUL-CRV-48
for 75 Gallon Receiver	INSUL-CRV-75
for 116 Gallon Receiver	INSUL-CRV-116

NON-ELECTRIC CONDENSATE PUMPS

Accessories & Options

Pressure Motive Pumps



Insulation Jacket

Insulation Jackets **conserve energy** by reducing heat loss. They also improve safety by protecting personnel from hot surfaces. Jackets have velcro closures for easy installation or removal. Fits tightly around pump tanks and receivers.

Patented "Snap-Assure" Feature

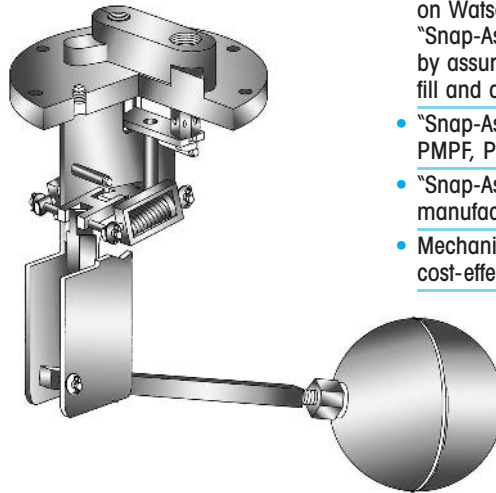

- Patented "Snap-Assure" feature is found only on Watson McDaniel's pump mechanisms. "Snap-Assure" extends the useful life of the pump by assuring the internal mechanism toggles at every fill and discharge.
- "Snap-Assure" is supplied standard in Models PMPC, PMPF, PMPT, PMPLS, PMPSS & PMPSP.
- "Snap-Assure" mechanisms will also fit other manufacturers' pump tanks.
- Mechanisms are simple and easy to replace, and are a cost-effective way to make your pump as good as new.

Snap-Assure Patent No. 6572340

Product Description	Model Code
PRE-PIPED ACCESSORIES:	
Pre-piped Pressure Regulating Valve (PRV) for motive steam or air	PRV1
Pre-piped Drip Leg Station with Steam Trap	PRV2
Pre-piped Drip Leg Station with Steam Trap and PRV	PRV3
Pre-piped Exhaust Line	PRV4
MECHANISMS:	
New Mechanism Assembly with Cover	
for PMPF	900-03
for PMPC, PMPLS	910-03
for PMPBP	900-02
for PMPT	921-03
for PMPM (cover not required)	911-03
REBUILT MECHANISMS: *	
for PMPF	900-03R
for PMPC, PMPLS	910-03R
for PMPT	921-03R
CHECK VALVES:	
Stainless Steel: 1/2" - 3" NPT	See WSSCV Page

* Note for Rebuilt Mechanisms:

The exchange program is for mechanisms with two years of service or less. The old mechanism must be returned along with the order for the rebuilt mechanism. Orders without old mechanisms will be invoiced at the new mechanism price.

NON-ELECTRIC CONDENSATE PUMPS

Sizing & Selection

Pressure Motive Pumps - Capacities

Watson McDaniel reserves the right to change the designs and/or materials of its products without notice.
©2010 Watson McDaniel Company

PUMPS

CAPACITIES – Condensate (lbs/hr) Using steam as a motive pressure												
Motive Pressure (PSIG)	Total Back Pressure (PSIG)	PMPLS 1" X 1" 6" Head	PMPC, PMPF, PMPSS*									PMPBP 4" x 4" 24" Head
			1 1/2" X 1" 12" Head	1 1/2" X 1 1/2" 12" Head	2" X 1" 12" Head	2" X 1 1/2" 12" Head	2" X 2" 12" Head	3" X 2" 12" Head	3" X 2" Duplex	3" X 2" Triplex	3" X 2" Quadraplex	
5	2	1,760	1,860	1,920	2,860	3,180	3,540	5,000	10,000	15,000	20,000	16,600
10	5	1,870	2,200	2,450	4,350	4,840	5,380	7,210	14,420	21,630	28,840	19,000
10	2	2,200	3,030	3,370	6,880	7,650	8,500	11,110	22,220	33,330	44,440	22,600
25	15	1,650	3,130	3,480	4,990	5,550	6,170	8,230	16,460	24,690	32,920	33,200
25	10	1,980	3,600	3,990	6,560	7,290	8,100	10,780	21,560	32,340	43,120	40,300
25	5	2,300	4,700	5,200	7,970	8,860	9,850	13,350	26,700	40,050	53,400	46,200
50	40	1,650	2,280	2,530	3,370	3,750	4,170	5,670	11,340	17,010	22,680	33,300
50	25	1,980	4,050	4,500	6,800	7,560	8,440	11,550	23,100	34,650	46,200	40,100
50	10	2,300	4,700	5,240	7,970	8,860	9,850	13,440	26,880	40,320	53,760	47,000
75	60	1,540	2,400	2,660	3,600	4,000	4,440	6,340	12,680	19,020	25,360	32,900
75	40	1,980	3,780	4,190	5,920	6,580	7,320	9,870	19,740	29,610	39,480	39,400
75	15	2,420	5,130	5,700	8,580	9,540	10,600	14,330	28,660	42,990	57,320	47,200
100	80	1,650	2,750	3,060	4,160	4,630	5,150	6,860	13,720	20,580	27,440	27,200
100	60	1,870	3,600	4,000	5,560	6,180	6,870	9,100	18,200	27,300	36,400	35,100
100	40	2,090	4,700	5,210	6,880	7,650	8,500	11,270	22,540	33,810	45,080	42,100
100	15	2,420	5,400	6,010	8,740	9,720	10,800	14,330	28,660	42,990	57,320	48,000
125	115	1,430	2,380	2,640	3,270	3,640	4,050	4,960	9,920	14,880	19,840	19,500
125	100	1,540	2,980	3,330	4,140	4,600	5,130	6,390	12,780	19,170	25,560	25,300
125	80	1,760	3,430	4,100	5,400	6,000	6,670	8,540	17,080	25,620	34,160	32,200
125	60	1,980	4,170	4,850	6,600	7,340	8,160	10,530	21,060	31,590	42,120	38,500
125	40	2,200	5,100	5,950	7,760	8,630	9,590	12,500	25,000	37,500	50,000	44,000
125	15	2,420	5,850	6,660	9,240	10,270	11,420	15,100	30,200	45,300	60,400	49,200
150	120	1,590	2,650	2,940	3,400	3,780	4,200	5,690	11,380	17,070	22,760	21,600
150	100	1,640	3,150	3,490	4,320	4,800	5,350	7,000	14,000	21,000	28,000	29,000
150	80	1,860	3,800	4,230	5,490	6,100	6,770	9,100	18,200	27,300	36,400	34,500
150	60	2,080	4,500	5,000	6,660	7,400	8,240	11,120	22,240	33,360	44,480	40,300
150	40	2,300	5,290	5,870	7,920	8,800	9,780	13,220	26,440	39,660	52,880	44,700
150	15	2,520	6,100	6,820	9,450	10,500	11,680	15,500	31,000	46,500	62,000	49,500
175	140	-	2,600	2,900	3,800	4,200	4,650	6,200	12,400	18,600	24,800	-
175	120	-	3,100	3,400	4,400	4,850	5,400	7,200	14,400	21,600	28,800	-
175	100	-	3,600	4,000	5,100	5,700	6,300	8,400	16,800	25,200	33,600	-
175	60	-	4,850	5,400	6,900	7,700	8,550	11,400	22,800	34,200	45,600	-
175	40	-	6,200	6,900	8,900	9,850	10,950	14,600	29,200	43,800	58,400	-
175	15	-	7,500	8,350	10,600	11,900	13,200	17,600	35,200	52,800	70,400	-
200	160	-	2,400	2,700	3,500	3,800	4,300	5,700	11,400	17,100	22,800	-
200	140	-	3,100	3,400	4,400	4,900	5,400	7,200	14,400	21,600	28,800	-
200	100	-	4,200	4,650	5,950	6,600	7,350	9,800	19,600	29,400	39,200	-
200	80	-	4,700	5,250	6,750	7,500	8,300	11,100	22,200	33,300	44,400	-
200	40	-	6,800	7,550	9,700	10,800	11,950	15,950	31,900	47,850	63,800	-
200	15	-	8,400	9,350	12,000	13,300	14,800	19,700	39,400	59,100	78,800	-

* PMPSS is rated to only 150 PSIG.

Capacity Correction Factors for Alternate Filling Heads							
Pump Inlet Size	Filling Head						
	6"	12"	18"	24"	36"	48"	60"
1"	1.00	1.10	1.20	1.30	1.50		
1 1/2"	0.70	1.00	1.10	1.20	1.35		
2"	0.70	1.00	1.10	1.20	1.35		
3"	0.84	1.00	1.04	1.08	1.20		
4"			0.80	1.00	1.10	1.15	1.20

NOTE: When the filling head differs from the standard filling height, the capacity of the pressure power pumps are either increased or decreased. For example, a pump with a 3" inlet that has a filling head of 36" as opposed to a standard filling head of 12", will have a capacity increase of 20%. Multiply the value found in the Capacity Table above by 1.2.

Capacity Correction Factors for Gas as Motive Pressure									
Pump Inlet Size	% Back Pressure relative to Motive Pressure								
	10%	20%	30%	40%	50%	60%	70%	80%	90%
1"	1.00	1.13	1.16	1.20	1.25	1.30	1.35	1.40	1.45
1 1/2"	1.04	1.06	1.08	1.10	1.12	1.15	1.18	1.23	1.28
2"	1.04	1.06	1.08	1.10	1.12	1.15	1.18	1.23	1.28
3"	1.04	1.06	1.08	1.10	1.12	1.15	1.18	1.23	1.28
4"	No Capacity Change								

Note: For slow-fill or low specific gravity applications, consult factory.

NON-ELECTRIC CONDENSATE PUMPS

Sizing & Selection

Pressure Motive Pumps - Capacities

Model PMPM - Pressure Motive Pump

CAPACITIES – Condensate (lbs/hr)					
Motive Pressure (PSIG)	Back Pressure (PSIG)	6" Filling Head			
		Steam Motive		Air Motive	
		1"	1 1/4"	1"	1 1/4"
25	15	1200	1800	1720	2580
25	5	1970	2955	2265	3398
50	40	1200	1800	1640	2460
50	25	1480	2220	1980	2970
50	15	1860	2790	2220	3330
50	5	2240	3360	2485	3728
75	60	1160	1740	1935	2903
75	40	1640	2460	2185	3278
75	25	1960	2960	2340	3510
100	60	1415	2122	2020	3030
100	40	1825	2732	2280	3420
100	25	1985	2977	2420	3630
100	15	2175	3262	2455	3683
150	100	1120	1680	1456	2184
150	80	1220	1830	1525	2288
150	60	1570	2355	1885	2828

WPT Series - Pump-Trap Combinations

CAPACITIES – Condensate (lbs/hr); using steam as a motive pressure						
Motive Pressure (PSIG)	Total Back Pressure (PSIG)	WPT1	WPT2	WPT3	WPT4	WPT5
		1" x 1" 6" Head	1 1/4" x 1 1/4" 6" Head	1 1/2" x 1 1/2" 12" Head	2" x 2" 12" Head	3" x 2" 12" Head
5	2	185	335	1310	2320	4270
10	5	370	648	1760	3740	6230
10	2	502	898	2350	5640	9450
25	15	958	1590	2700	4690	7230
25	10	1240	2090	3020	5970	9370
25	5	1490	2570	3780	6850	11400
50	40	1010	1610	2090	3410	5040
50	25	1220	1970	3620	6650	10200
50	10	1600	2680	4080	7140	11500
75	60	993	1560	2250	3730	5660
75	40	1380	2190	3470	6010	8770
75	15	1550	2580	4390	7920	12400
100	80	612	951	2620	4390	6140
100	60	1210	1900	3390	5780	8120
100	40	1540	2440	4310	6940	10000
100	15	1720	2840	4620	8000	12300
125	115	195	301	2280	3490	4440
125	100	488	753	2880	4420	5720
125	80	836	1300	3520	5700	7630
125	60	1280	2000	4110	6880	9390
125	40	1420	2270	4910	7800	11100
125	15	1470	2440	5120	8420	12900
150	120	588	904	2560	3640	5100
150	100	977	1510	3020	4610	6270
150	80	1060	1640	3630	5780	8140
150	60	1340	2100	4230	6910	9920
150	40	1420	2260	4830	7930	11700
150	15	1450	2390	5230	8590	13300

Sizing & Selection

Watson McDaniel reserves the right to change the designs and/or materials of its products without notice.
©2010 Watson McDaniel Company

Pressure Motive Pumps

Sizing & Selection

The capacity of a Pressure Motive Pump is determined by the Model and the size of the inlet and outlet check valves. The larger the check valves used, the more capacity the pump can handle. For example: The 3" x 2" pump has a 3" inlet check valve and a 2" outlet check valve.

STAND-ALONE PUMPS are furnished with pump tank, check valves and internal pumping mechanism.

PUMPS WITH RECEIVER TANKS include the stand-alone pump(s), check valves, and receiver tank mounted together on a frame. These are available in Simplex, Duplex, Triplex and Quadraplex systems.

When sizing and selecting a Pressure Motive Pump, **five** system conditions are required:

(See Diagram on following page)

- 1 Condensate Load
- 2 Condensate Pressure
- 3 Motive Steam, Air or other Gas Pressure available for operating the pump
- 4 Available Filling Head between the bottom of the receiver tank and the top of the pump tank
- 5 Total System Back Pressure (BP)
 - a) Condensate Return Line Pressure (5A)
 - b) Vertical Height condensate must be lifted (5B)

SAMPLE SYSTEM CONDITIONS

1 Condensate Load	8,000 lbs/hr
2 Condensate Pressure	50 PSIG
3 Motive Steam Pressure	Steam @ 100 PSIG
4 Filling Head	12"
5 Total Back Pressure = a + b	
a) Line Pressure	30 PSIG
b) Vertical Lift	23 ft. (convert to PSIG)

Calculation of Total Back Pressure:

To find the pressure required to lift condensate in PSIG, multiply the lift in feet by 0.433.

Pressure required to lift Condensate (0.433 x 23 ft.)	10 PSIG
Pressure in Return Pipe	+ 30 PSIG
Total Back Pressure	= 40 PSIG

Open Loop with Vented Receiver

(When draining condensate from multiple sources)

For PMP Sizing:

Consult PMP Sizing Capacity Chart using 100 PSIG inlet pressure and 40 PSIG back pressure. A 2" x 2" pump has a capacity of 8,500 lbs/hr and is an appropriate selection. Pump choices are models PMPC, PMPF and PMPSS.

For Receiver and Vent Connection Sizing:

Refer to the Vented Receiver Sizing Chart for guidelines on how to calculate the flash steam generated and use this value to size the receiver and vent connection.

Closed Loop with Pressurized Reservoir

(When draining condensate from a single piece of heat transfer equipment)

For PMP and Trap Sizing:

Reference PMPT and WPT Pump-Trap Combination Capacity Charts for an estimation of the unit required. Contact factory for more accurate sizing.

For Reservoir Pipe Sizing

Refer to the Reservoir Pipe Length Chart for guidelines on determining the appropriate diameter and length of pipe required for condensate back-up.

HOW TO ORDER

SPECIFY:	EXAMPLE:
1) Model or Pumps	PMPC
2) Size of Pump(s)	2" x 2"
3) Stand-alone Pump or Pump with Receiver Tank	Simplex or Duplex
<i>(Note: Size of Receiver Tank must be specified when ordering Pump with Receiver Tank)</i>	
4) Options	Gauge glass
5) When ordering a Customized Skid System, please confirm and specify Receiver size.	

NON-ELECTRIC CONDENSATE PUMPS

Sizing & Selection

Pressure Motive Pumps

PMP Sizing & Selection

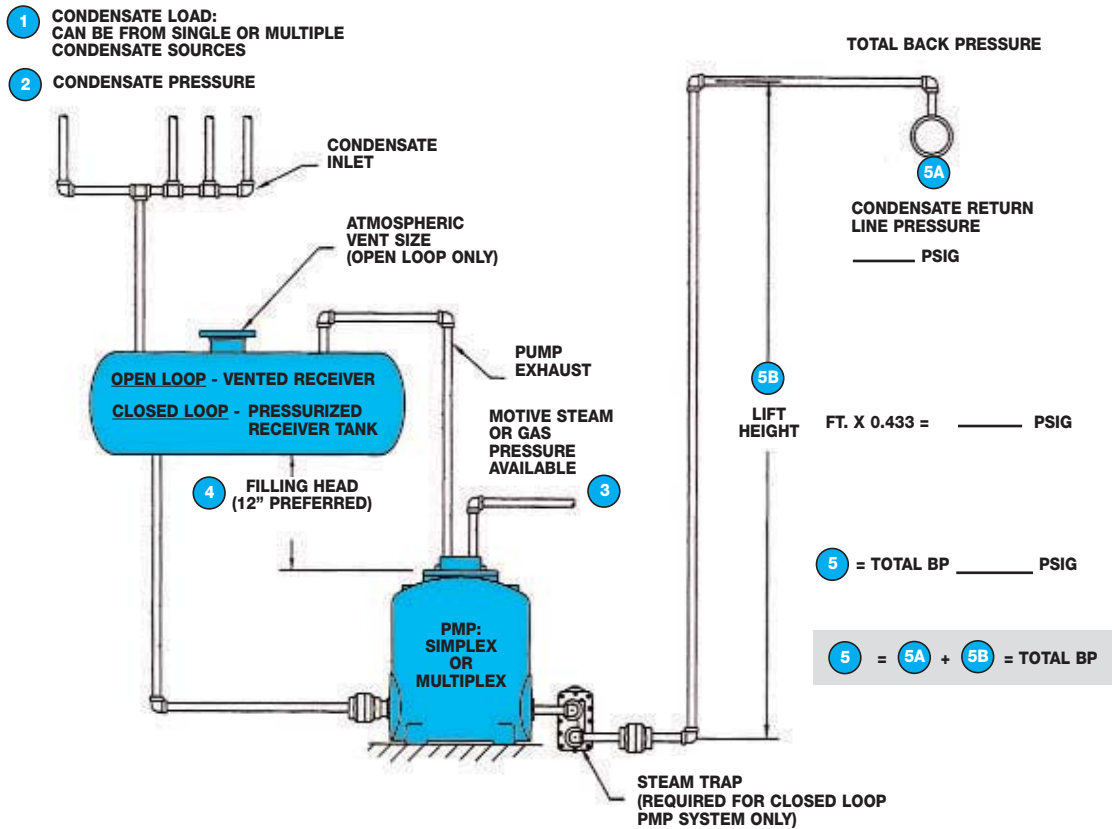

Simplex or Multiplex PMP System

NON-ELECTRIC CONDENSATE PUMPS

Sizing & Selection

Pressure Motive Pumps

PUMPS

Closed Loop System (Pressurized Reservoir)

RESERVOIR SIZING

When sizing **Pressure Motive Pumps** for closed loop return systems, a condensate reservoir should be installed on the inlet side of the pump and below the equipment to be drained. This will enable the condensate to collect while the pump is in the discharge cycle, thus preventing liquid backup into the equipment. The **Reservoir Sizing Table** (at right) gives the minimum pipe size & length to produce the required reservoir volume to accommodate the condensate load.

How to select: Determine the **total condensate load** to be pumped. Find that load value or greater in the table and move right to read the pipe lengths in feet with the diameters indicated above.

Customized reservoirs can be designed to accommodate specific space and dimensional requirements. It is critical for these designs to have adequate vapor space for condensate to collect. When the volume required is known, from the table at right, optional pipe diameters and lengths can be selected to provide the same or greater volume. This table will allow you to convert required volumes to customized sizes needed. Watson McDaniel can furnish customized Pressure Motive Pump Packages to fit your needs.

RESERVOIR PIPE LENGTH in feet (ft)

Condensate Load (lbs/hr)	Reservoir Pipe Size (Diameter)				
	3"	4"	6"	8"	10"
0-500	2'				
1,000	2'				
1,500	3'	2'			
2,000	3.5'	2'	1'		
3,000		3'	2'		
4,000		4'	2'	1'	
5,000		6'	3'	2'	
6,000			3'	2'	
7,000			3'	2'	
8,000			4'	2'	
9,000			4.5'	3'	2'
10,000			5'	3'	2'
20,000				5.5'	4'

Note: When back pressure against the pump outlet is less than 50% of the steam pressure to the heat exchanger, the above pipe lengths can be reduced by half.

DATA REQUIRED FOR SIZING PMP IN A CLOSED LOOP SYSTEM (pressurized reservoir)

Single Condensate Source

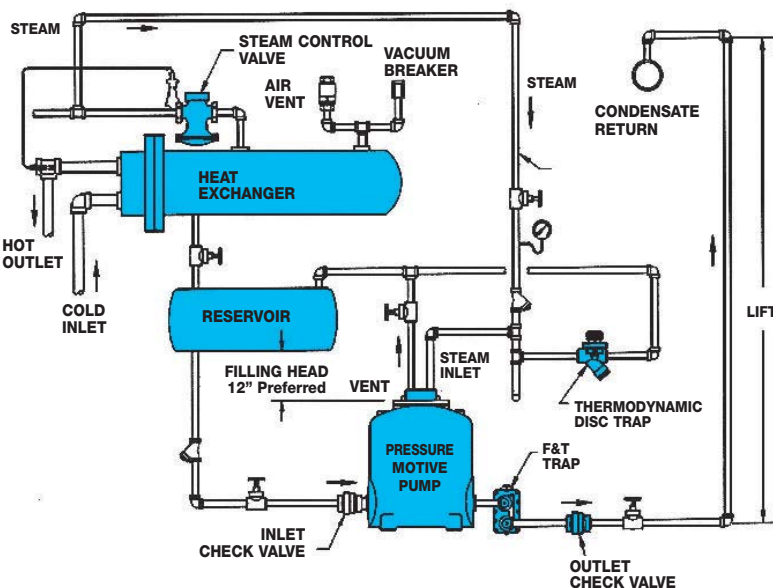

Condensate Load produced by Heat Transfer Equipment (i.e. heat exchangers, tank coils, jacketed kettles, etc.)
_____ lbs/hr

(If this information is not readily available, consult Engineering Section in the back of this catalog for additional methods of load determination.)

Motive Steam Pressure (Steam Motive Only):
_____ PSIG

Total Back Pressure = a + b

a) Pressure required to lift condensate:

Vertical height in ft. x 0.433 = _____ PSIG

b) Pressure in condensate return line: _____ PSIG

Is there enough **clearance** under the equipment and/or piping to allow for the installation of the Reservoir and PMP with the Preferred Filling Head of 12" as illustrated?

To **size the PMP and Trap combination**, see PMPT or WPT Capacity charts for general reference.

(For additional information on the effect of the steam trap in a closed loop application, refer to expanded information later in this section. For more accurate sizing of Pump-Trap systems to account for system stall conditions, consult factory.)

To **size the Reservoir**, see Reservoir Pipe Length chart.

Sizing & Selection

Pressure Motive Pumps

Open Loop System (Vented Receiver)

RECEIVER & VENT SIZING

When sizing a Pressure Motive Pump for an Open-Loop atmospheric return system, the amount of flash steam to be vented from the receiver must be calculated. Vent sizing is critical to maintain 0 PSIG in the receiver tank to allow free drainage of low pressure systems. Undersized vents will cause gradual pressure increase in the receiver. This impedes drainage from the condensate source, and can cause waterlogging of the system.

Usually the condensate load to be pumped comes from multiple sources. For each source determine

the pressure and load. Then go into the **Percent Flash Steam** table with the condensate pressure and move right until under the appropriate flash tank pressure to read the percentage of condensate that will flash into steam. Take the source load and multiply it by the decimal value of the percentage to calculate the amount (lbs/hrs) of flash steam. Repeat this for all condensate sources. Enter the **Vented Receiver Sizing** table with the **total flash steam load** to determine the correct sizes for receiver and vent.

VENTED RECEIVER SIZING (inches)			
Quantity of Flash Steam (lbs/hr)	Receiver Diameter	Receiver Length	Vent Line Diameter
75	4"	36"	1"
150	6"	36"	2"
300	8"	36"	3"
600	10"	36"	4"
900	12"	36"	6"
1200	16"	36"	6"
2000	20"	60"	8"
3000	24"	60"	8"
4000	26"	60"	10"
5000	28"	60"	10"
6000	30"	72"	12"
7000	32"	72"	12"
8000	36"	72"	14"

PERCENT (%) FLASH STEAM

Produced when condensate is discharged to atmosphere or into a flash tank controlled at various pressures

Condensate Pressure (PSIG)	Flash Tank Pressure (PSIG)								
	0	5	10	20	30	40	60	80	100
5	1.6	0.0							
10	2.9	1.3	0.0						
15	3.9	2.4	1.1						
20	4.9	3.3	2.1	0.0					
30	6.5	5.0	3.7	1.7	0.0				
40	7.8	6.3	5.1	3.0	1.4	0.0			
60	10.0	8.5	7.3	5.3	3.7	2.3	0.0		
80	11.8	10.3	9.1	7.1	5.5	4.2	1.9	0.0	
100	13.3	11.8	10.6	8.7	7.1	5.8	3.5	1.6	0.0
125	14.9	13.5	12.3	10.4	8.8	7.5	5.3	3.4	1.8
150	16.3	14.9	13.7	11.8	10.3	9.0	6.8	4.9	3.3
200	18.7	17.3	16.2	14.3	12.8	11.5	9.4	7.6	6.0
250	20.8	19.4	18.2	16.4	14.9	13.7	11.5	9.8	8.2
300	22.5	21.2	20.0	18.2	16.8	15.5	13.4	11.7	10.2
350	24.1	22.8	21.7	19.9	18.4	17.2	15.1	13.4	11.9
400	25.6	24.2	23.1	21.4	19.9	18.7	16.7	15.0	13.5

DATA REQUIRED FOR SIZING PMP IN AN OPEN LOOP SYSTEM (vented receiver)

Multiple Condensate Sources

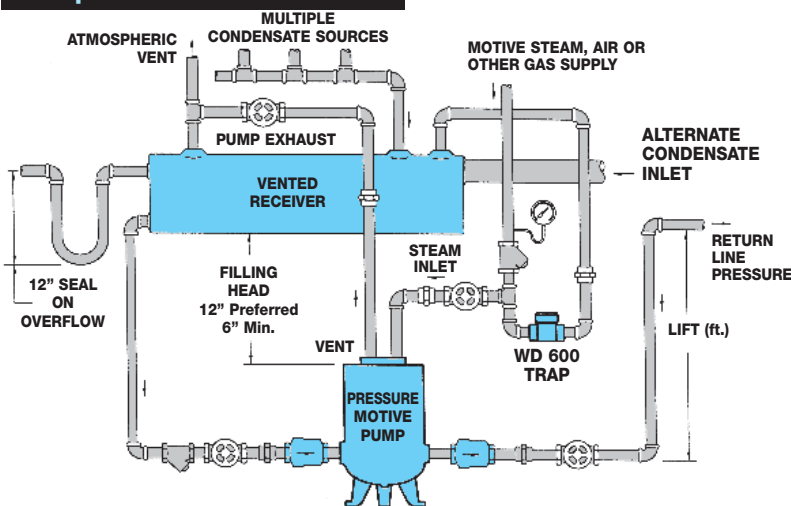

Source 1: ___ lbs/hr @ ___ PSIG
 Source 2: ___ lbs/hr @ ___ PSIG

Motive Gas and Pressure:
 (Steam, Air, Other) @ ___ PSIG

Total Back Pressure = a + b

- a) Pressure required to lift condensate:
 Vertical height ___ ft. x 0.433 = ___ PSIG
- b) Pressure in return pipe: ___ PSIG

Is there enough **clearance** under the equipment and/or piping to allow for the installation of the Receiver and PMP with the Preferred Filling Head of 12" as illustrated?

To **size the PMP**, see Pump Capacity chart.

To **size the Receiver and Vent connection**, see Vented Receiver Sizing chart.

NON-ELECTRIC CONDENSATE PUMPS

Sizing & Selection

Pressure Motive Pumps

Watson McDaniel reserves the right to change the designs and/or materials of its products without notice.
©2010 Watson McDaniel Company

Problem: Stalled Heat Exchanger

DESCRIPTION:

STALL CONDITION WITH MODULATED STEAM FLOW

When a modulating valve is used to control product temperature in heat transfer equipment, the valve will open and close as necessary to meet the variable demand of the system to maintain the product at constant temperature. Therefore, when maximum heating is required, the supply valve will be fully open to satisfy the high steam demand requirement. At this point, pressure is also being supplied at its highest level, which may be sufficient to overcome total system back pressure.

As the product temperature is satisfied, demand decreases and the valve correspondingly begins to close, reducing pressure differential. If demand is satisfied, the valve modulates to its fully closed position. Inlet supply pressure will eventually fall below system back pressure, resulting in system stall. This leads to poor heat transfer and water hammer as condensate backs up in the heat transfer equipment.

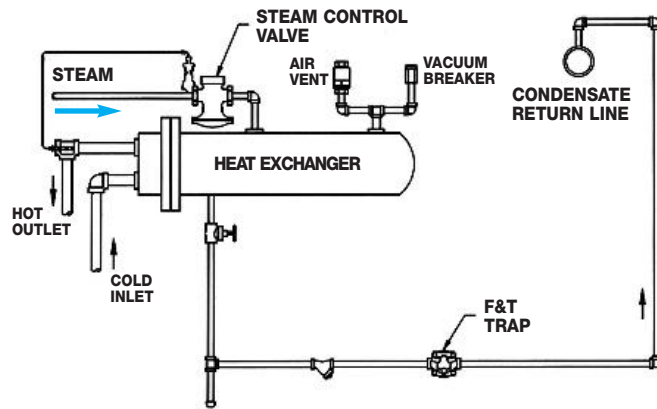

Heat Exchanger System without PMP

Solution: Use PMP & Steam Trap Combination

DESCRIPTION:

USE A PRESSURE MOTIVE PUMP AND STEAM TRAP COMBINATION

(Available in INTERNAL and EXTERNAL Steam Trap designs)

When the supply valve is fully open and inlet pressure exceeds back pressure, condensate forming in the heat transfer equipment will be pushed through the pump and steam trap into the condensate return line. As the supply valve begins to close and the back pressure exceeds inlet pressure, any condensate forming inside the heat transfer equipment will drain by gravity into the pump tank. The condensate will accumulate in the pump tank until the float mechanism reaches its trip point. The "tripping" of the mechanism opens the motive valve to allow high pressure steam into the tank to drive the condensate from the tank to the condensate return line.

Note: A larger steam trap than normally required to drain the heat transfer equipment must be used to handle the high instantaneous discharge rate of the pump. See additional information in this catalog for sizing guidelines.

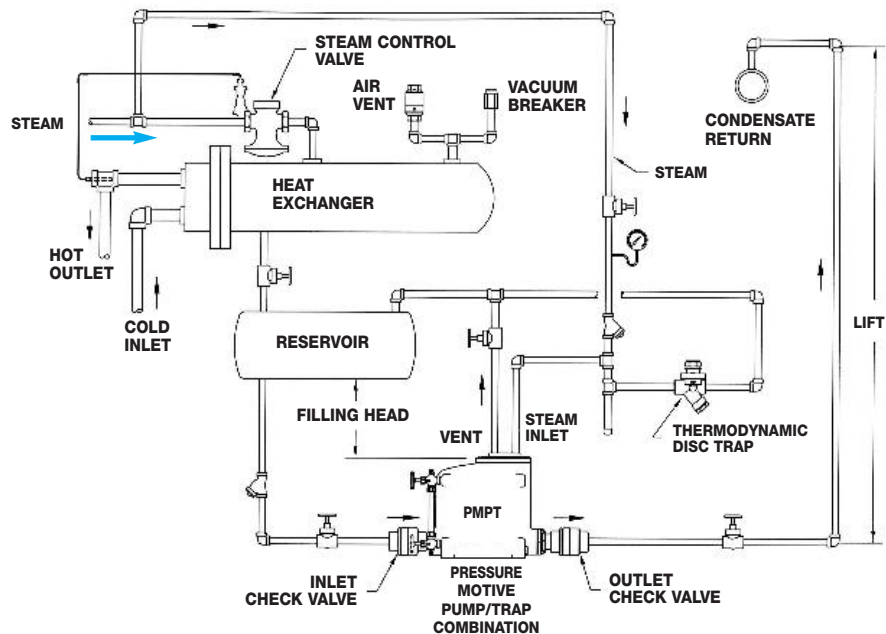

Heat Exchanger System with PMP & Internal Trap (PMPT) (Closed Loop System)

Sizing & Selection

Pressure Motive Pumps

CLOSED LOOP SYSTEMS – SIZING CONSIDERATIONS for PUMP-TRAP COMBINATION

What is Stall?

STALL is the condition of a modulating system where inlet pressure can no longer overcome back pressure, preventing condensate drainage and resulting in poor heat transfer and waterhammer.

Although Pressure Motive Pumps can be supplied as stand-alone units, the vast majority of industrial condensate transfer applications require a complete system of components to function both properly and efficiently. This section is intended to familiarize the user with the information and components required to provide an efficient system:

The Solution to Stall

Install a Watson McDaniel Pump and Steam Trap Combination – available in both Internal and External Steam Trap designs.

The PMPT Pump with Internal Steam Trap should be considered for compactness, while the WPT Series Pump-Trap Combination with External Steam Trap should be considered when capacities exceed the capability of the PMPT.

Why is a Steam Trap necessary after the PMP in a Closed Loop system?

Because this type of system operates with a modulating supply valve as described above, the pressure may, at times, both exceed or fall below system back pressure. The pump is only required during stall loads. Therefore, a steam trap is still required to prevent steam from discharging into the return line at times when the supply pressure exceeds the back pressure. When properly sized and installed, these two components will automatically work in conjunction with each other requiring no manual operation.

It is important to note that sizing the steam trap in a pump-external trap* combination application differs from sizing a steam trap alone. Please refer to additional information below.

** Although the steam trap is internal in the PMPT Series, it is still appropriate to follow the guidelines below for sizing confirmation.*

Sizing of a Pump-Trap Combination for a Closed Loop System

Although the PMP and Steam Trap operate in conjunction with each other, each component must be considered individually, as there are specific considerations for closed loop systems. See below for detailed explanation and appropriate guidelines for sizing of both the PMP and Trap components of the Pump-Trap Combination:

Proper Sizing of the PMP in a Pump-Trap Application

When required for drainage of heat transfer equipment supplied by a modulating control valve, the PMP need only be sized for the stall load, which is often considerably less than equipment design load leading to a smaller PMP being required. The point at which stall occurs can be calculated using either Stall Charts or appropriate formulas as shown on the following pages.

Proper Sizing of the Steam Trap in a Pump-Trap Application

In such an application, the steam trap must be sized not only to handle the full design load, but also sized to handle the high instantaneous flow rates from the discharge of the pump at stall conditions – which can be well in excess of 3 times the steady-state load of the pump! Therefore, it is appropriate to size the steam trap for both sets of conditions using the following guidelines:

- Steam Trap sizing based on **Full Design Load** of the Heat Transfer Equipment:
Full Design Load X appropriate Safety Load Factor = Total Load for Steam Trap Sizing
- Steam Trap sizing based on **Instantaneous Discharge** of the PMP – at stall conditions:
Stall Load (as determined) at 1/4 PSI differential for Steam Trap Sizing

Sizing & Selection

Pressure Motive Pumps

Watson McDaniel reserves the right to change the designs and/or materials of its products without notice.
©2010 Watson McDaniel Company

Predicting Stall

Stall can be predicted with relative accuracy by either plotting values on a Stall Chart or by calculation using appropriate formulas. These methods are then used to determine the percentage of heat load at stall. Examples of each method are offered so the user may choose the method with which they are most comfortable.

The example below is for a typical heat transfer application**, such as a heat exchanger where steam may be used to heat a constant flow of water at a fixed temperature. The parameters of such an application can be summarized as:

- The flow of the fluid to be heated is constant
- The desired outlet temperature of the heated fluid is to remain constant
- The steam for heating is to be supplied with a modulating valve (i.e. varying inlet pressure)

** Applications with alternate parameters will require different equations and guidelines for prediction of stall conditions. Consult factory for other such applications.

Example:

Consider a heat exchanger supplied with 40 PSIG steam through a modulating valve that is designed to heat a constant water flow of 145 GPM from 60 °F to 140 °F. Condensate will need to be lifted 23 ft. into a return line that has approximately 5 PSIG back pressure.

Before the charts or formulas can be consulted, some additional conversions are first required:

- 1) **The Saturated Temperature of the incoming steam:** In this example, consult the Saturated Steam Table (included in the Engineering Section of this catalog) to determine the Saturated Temperature of 40 PSIG steam is 287 °F.
- 2) **The equivalent Saturated Temperature of the total BACK PRESSURE:** The total back pressure is equal to the lift height equivalent pressure, plus any pressure that may exist in the return line.
 - 23 ft. Lift Height x 0.433 = 10 PSIG
 - Return Line Pressure = 5 PSIG

Therefore, the total BACK PRESSURE in this example is 15 PSIG. Consulting the Saturated Steam Table, the saturated temperature of 15 PSIG steam is 250 °F.

DETERMINING PERCENTAGE OF HEAT LOAD AT STALL

The parameters required for determining stall can now be summarized as follows:

- Inlet Steam Pressure at Full (100%) Load = 40 PSIG (P_s)
- Inlet Steam Temperature at Full (100%) Load = 287 °F (T_s)
- Outlet Temperature of Heated Fluid = 140 °F (T_2)
- Back Pressure (lift height + line pressure) = 15 PSIG (P_b)
- Back Pressure equivalent saturated steam temperature = 250 °F (T_b)

Mathematical Solution

$$\begin{aligned} \% \text{ Heat Load at Stall} &= \frac{T_b - T_2}{T_s - T_2} \times 100\% \\ &= \frac{250 - 140}{287 - 140} \times 100\% \\ &= \frac{110}{147} \times 100\% \\ &= 74.8\% \end{aligned}$$

Graphical Solution (see Figure No. 1)

- 1) On the Left Vertical Axis, plot the Inlet Steam Temperature (T_s): 287 °F.
- 2) On the Left Vertical Axis, find the Outlet Temperature of the fluid to be heated (T_2): 140 °F. Plot this point directly across on the Right Vertical Axis. Draw line between points T_s and T_2 .
- 3) On the Right Vertical Axis, plot the Back Pressure: 15 PSIG. Draw a horizontal line from this point to the Left Vertical Axis.
- 4) Locate the point at which the above lines intersect. Draw vertical line from this point to the Bottom Horizontal Axis to determine the Percentage of Load at which Stall occurs – 75% in this example.

NON-ELECTRIC CONDENSATE PUMPS

Sizing & Selection

Pressure Motive Pumps

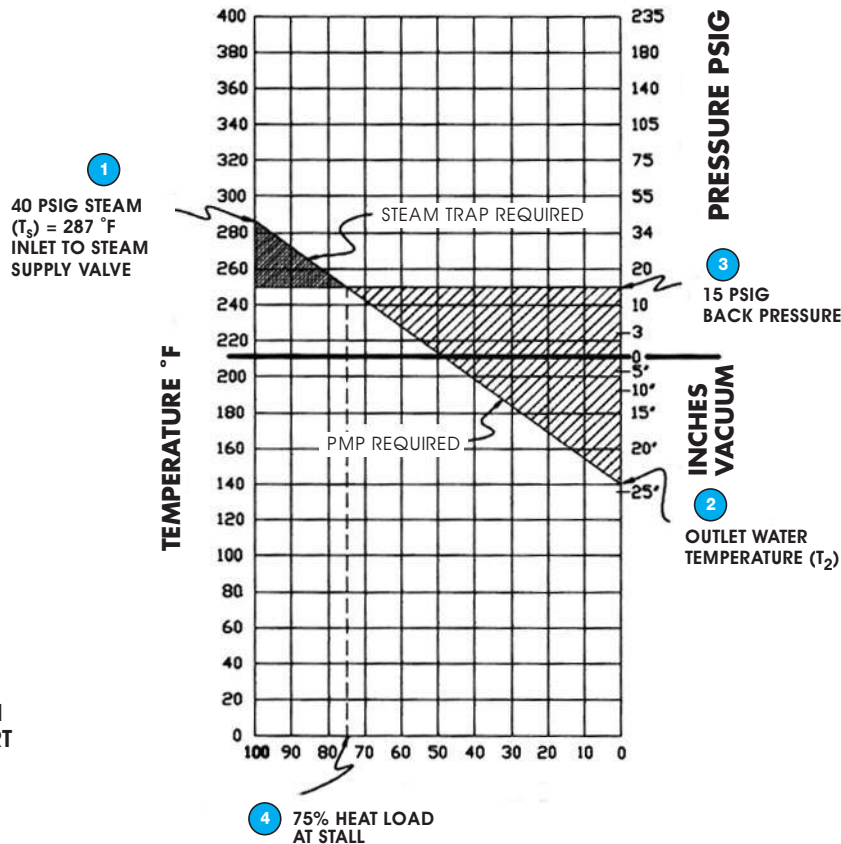

Figure No. 1
STALL CHART

DETERMINING LOAD AT STALL

The load was not specified in the example provided. However, sufficient information was provided for its calculation. Here is what is known:

- Steam Supply Pressure = 40 PSIG
- Constant Water Flow = 145 GPM
- Water Heating Requirements = 60 °F to 140 °F

Consulting the Engineering Section in the back of this catalog, the following equation for steam load requirements at heat exchanger full load can be used:

$$\begin{aligned}
 \text{Steam Load in lbs/hr} &= \frac{\text{GPM} \times \text{Temp. Rise } ^\circ\text{F}}{2} \\
 &= \frac{145 \times (140-60)}{2} \\
 &= 5,800 \text{ lbs/hr}
 \end{aligned}$$

At 100% open, the inlet steam valve will supply 5,800 lbs/hr for heating. We can now determine the stall load to be used for proper sizing of the Pump-Trap Combination. From the previous section, stall was determined to occur at 75% of the full load. Therefore:

$$\text{Stall Load} = 5,800 \text{ lbs/hr} \times 0.75 = 4,350 \text{ lbs/hr}$$

Finally, using the guidelines previously noted within this section, the PMP and Steam Trap can be properly sized and selected. As always, consult the factory for additional information and sizing assistance when needed.

NON-ELECTRIC CONDENSATE PUMPS

Customized Skid Packages

Watson McDaniel reserves the right to change the designs and/or materials of its products without notice.
©2010 Watson McDaniel Company

Pressure Motive Condensate Pumping Systems

PUMPS

Custom Fabricated Units

Watson McDaniel's fully equipped ASME qualified fabrication facility stands ready to assist you with all of your fabrication needs. Our engineering staff specializes in the design of Pressure Motive Condensate Pumping Systems for both industrial and institutional applications. You can order either standard packages, available from stock, or specialized systems to meet your specific needs.

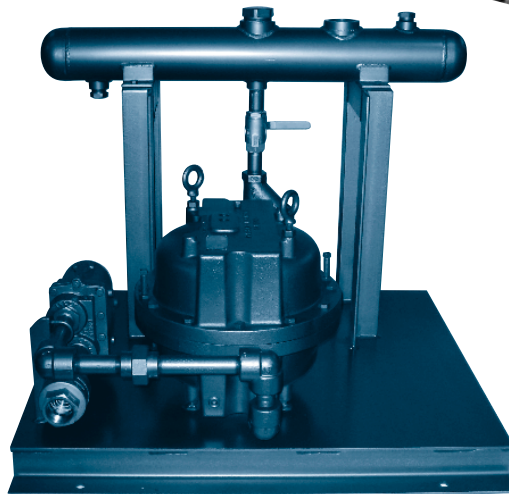
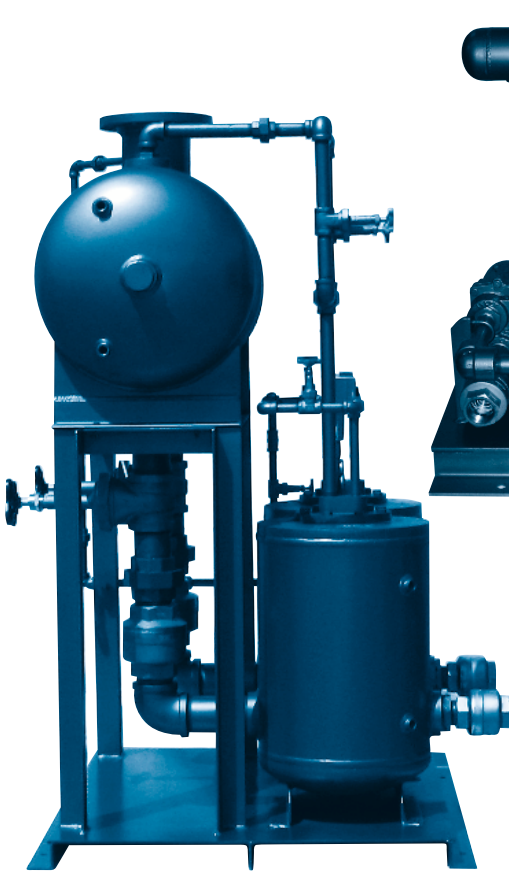
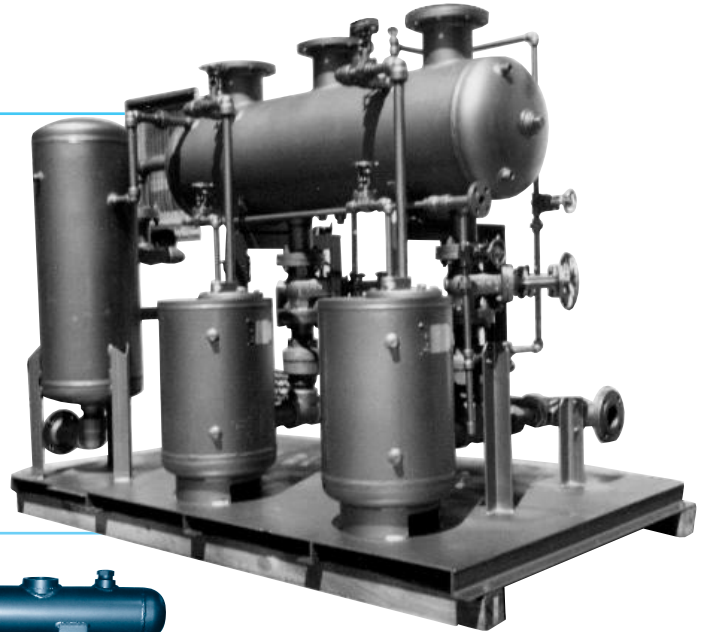

**ASME
Certified**



NON-ELECTRIC CONDENSATE PUMPS

Custom Skid Packages

Pressure Motive Condensate Pumping Systems

DESCRIPTION OF CUSTOM SYSTEM

This "Closed Loop" Duplex Pump package utilizes two PMPF Pumps, two FTE Steam Traps, and one 65 gallon receiver tank equipped with a safety relief valve. The Receiver is vented to take the flash steam away at 29 PSIG for usage elsewhere in the plant. To accomplish this, our **pilot-operated back pressure regulator (BPR)** is mounted just off the vent line and set to maintain the 29 PSIG pressure. If pressure exceeds the set, the BPR unit will dump to atmosphere thru the supply acoustic silencer.

Another custom feature is an overflow circuit utilizing a custom flash tank equipped with a **Temperature Regulator** for cooling applications. In the event of a pump failure, the flooded receiver will overflow the hot condensate into the flash vessel where steam will vent to atmosphere while the condensate gets injected with cold water to safely dump to drain.

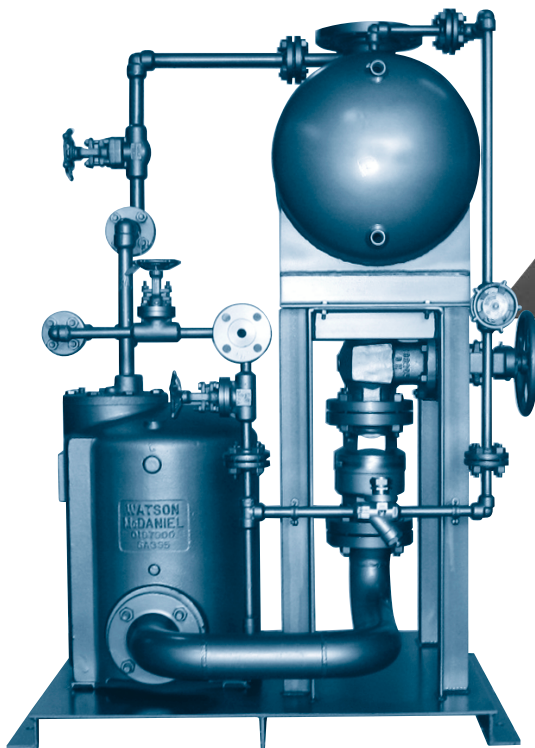
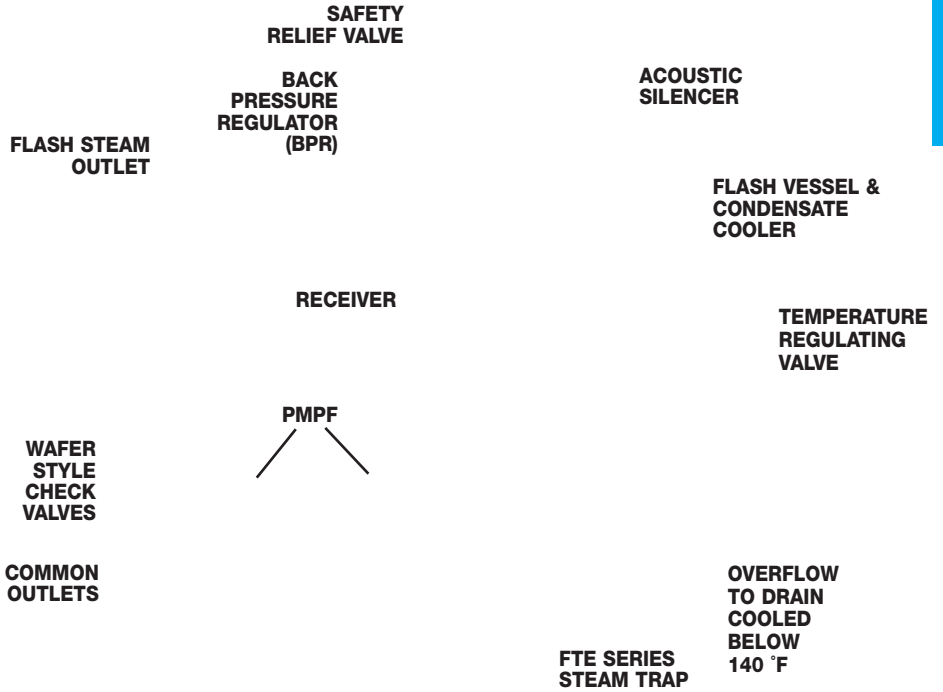

ELECTRIC PUMPS

W4100 & W4200

Electric Condensate Pump

Watson McDaniel reserves the right to change the designs and/or materials of its products without notice.
©2010 Watson McDaniel Company

Model	W4100	W4200
Tank Sizes	8/15/30/45/60/95 Gal.	6/15/24/36/50 Gal.
Connections	NPT	NPT
Tank Material	Fabricated Carbon Steel	Cast Iron
Max Disch. Press.	50 PSIG *	50 PSIG *
TMO/TMA	190°F	190°F
Options	Mechanical & electrical alternators; gauge glass; thermometer; discharge pressure gauges; isolation valves; magnetic starters; 1750 RPM motors; control panels; oversized or stainless steel receivers; high temperature components	

* Optional higher ratings available.

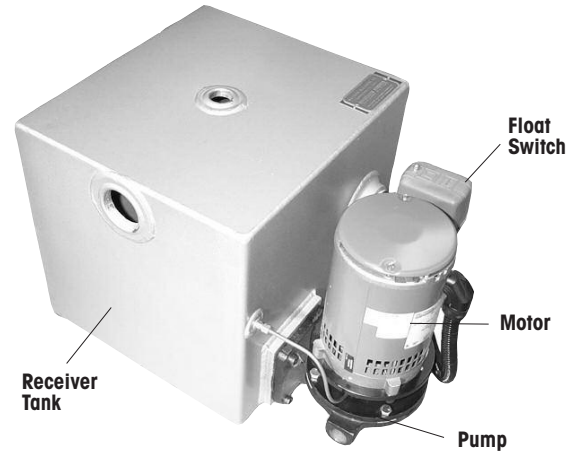

TYPICAL APPLICATIONS

The primary purpose of the **W4100** and **W4200** electric condensate pumps are to return condensate back to the boiler. Pumping condensate over 190°F is not recommended with these pumps due to potential mechanical seal failure.

HOW IT WORKS

The float, which is connected to the switch assembly rises when condensate enters the receiver tank. When the float rises above its set point, it energizes the motor on the pump. Once started, the pump will continue to run until the water level drops below the bottom position of the float switch. There it will de-energize the motor to shut off the pump. This cycle repeats as condensate begins to fill the receiver tank.

FEATURES

- Fabricated steel receivers (W4100) or cast iron receivers (W4200)
- Simplex and duplex packages
- Bronze-fitted centrifugal pumps
- Energy-efficient 3450 RPM motors
- Automatic venting
- Ceramic pump seal
- Heavy-duty float switch
- All steel receivers, and iron receivers over 24 gallons include a threaded NPT overflow port

SAMPLE SPECIFICATION

Pump(s) shall be of the centrifugal type with two-piece enclosed brass impeller, cast iron housing and stainless steel motor shaft. The float switch shall be two-pole with plastic case, stainless steel float and shafting, and double-break silver contacts. A flat perforated brass strainer shall be provided in the inlet of the pump from the tank.

INSTALLATION

Place on an elevated, level and substantial foundation in a clean, dry and accessible area. Locate receiver tank inlet below lowest point of the condensate return lines.

MAINTENANCE

At regular intervals, check the motor lubrication, unless the motor is equipped with a permanently lubricated bearing.

OPTIONS

- Mechanical and electrical alternators
- Gauge glass
- Thermometer
- Discharge pressure gauges
- Isolation valves
- Magnetic starters with HOA selector switch
- 1750 RPM motors, larger pumping capacities & higher discharge pressures
- Wide variety of control panels
- Oversized receivers (45, 60 & 95 gallons)
- Stainless Steel receivers
- High Temperature (250°F) Components

HOW TO ORDER

Specify the discharge pressure, gallons per minute and voltage requirements when ordering.

ELECTRIC PUMPS

W4100 & W4200

Electric Condensate Pump

PUMPS

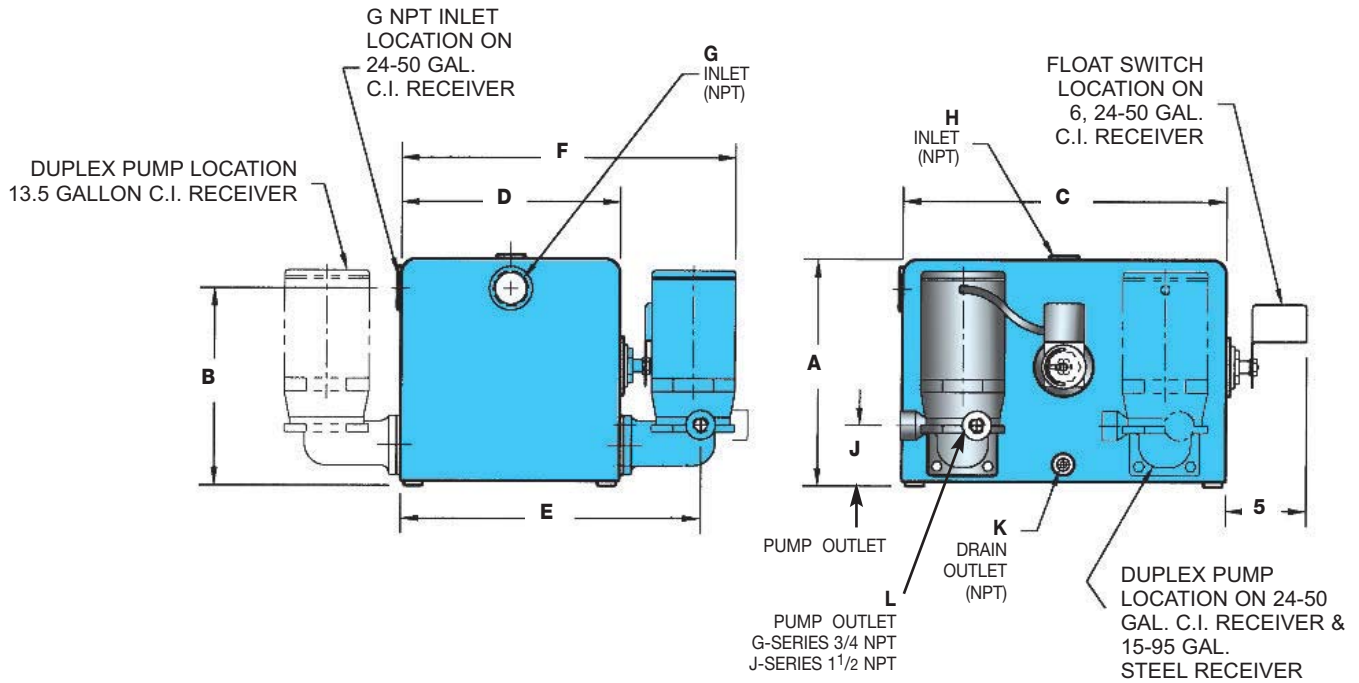

W4100 (Steel Receiver) Dimensions – inches

Series	Receiver Size	A	B	C	D	E	F	G	H	J	K	L
G	8 gallon	12 ³ / ₄	10 ¹ / ₂	12 ¹ / ₂	12 ¹ / ₂	18	21 ¹ / ₂	2	1 ¹ / ₂	4 ¹ / ₈	1/2	3/4
	15 gallon	14 ³ / ₈	12 ³ / ₈	17	15	20 ¹ / ₂	23 ¹ / ₄	2				
	30 gallon	18 ³ / ₈	16 ¹ / ₈	22	18	23 ¹ / ₂	28	2 ¹ / ₂				
J	45 gallon	26 ³ / ₈	24 ¹ / ₈	22	18	---	29 ⁵ / ₁₆	2 ¹ / ₂	1	3 ¹ / ₄	1/2	1 ¹ / ₂
	60 gallon	28 ³ / ₈	26 ¹ / ₈	28	18	---	29 ⁵ / ₁₆	2 ¹ / ₂				
	95 gallon	28 ³ / ₈	26 ¹ / ₈	28	28	---	39 ⁵ / ₁₆	2 ¹ / ₂				

W4200 (Cast Iron Receiver) Dimensions – inches

Series	Receiver Size	A	B	C	D	E	F	G	H	J	K	L
G	6 gallon	4 ¹ / ₂	12 ¹ / ₂	14 ¹ / ₂	12 ⁵ / ₈	18 ¹ / ₄	20 ⁷ / ₁₆	2	3/4	4 ³ / ₃₂	3/4	3/4
	15 gallon	14 ⁷ / ₈	13 ¹ / ₈	18 ¹ / ₂	13 ¹ / ₂	19 ¹ / ₈	24	2	1	3 ³ / ₄	1/2	3/4
	24 gallon	19 ¹ / ₈	15 ⁵ / ₈	25 ⁷ / ₈	15	20 ¹ / ₃₂	22 ¹³ / ₁₆	2	1	4 ¹ / ₈	3/4	3/4
	36 gallon	18 ⁵ / ₈	15 ¹ / ₈	27 ²¹ / ₆₄	22 ¹ / ₂	27 ¹⁷ / ₃₂	31 ³ / ₄	3	1	4 ¹ / ₈	3/4	3/4
J	36 gallon	18 ⁵ / ₈	15 ¹ / ₈	27 ²¹ / ₆₄	22 ¹ / ₂	---	35 ³ / ₈	3	1	4 ³ / ₈	3/4	1 ¹ / ₂
	50 gallon	18 ⁵ / ₈	15 ¹ / ₈	27 ²¹ / ₆₄	31	---	43 ⁷ / ₈	3	1	4 ³ / ₈	3/4	1 ¹ / ₂

ELECTRIC PUMPS

W4100

Watson McDaniel reserves the right to change the designs and/or materials of its products without notice.
©2010 Watson McDaniel Company

Electric Condensate Pump with Steel Receiver

PUMPS

CAPACITIES								
EDR	Discharge Pressure (PSIG)	Flow Rate (GPM)	Motor HP	Receiver Capacity (gallons)	Simplex Model #	Weight (lbs)	Duplex Model #	Weight (lbs)
8000	20	12	1/3	8	W4028G	90	N/A	N/A
2000	20	3	1/3	15	W4122G	125	W4122GD	185
4000	20	6	1/3	15	W4124G	125	W4124GD	185
6000	20	9	1/3	15	W4126G	125	W4126GD	185
8000	20	12	1/3	15	W4128G	125	W4128GD	185
10000	20	15	1/2	30	W41210G	190	W41210GD	240
15000	20	22.5	1/2	30	W41215G	190	W41215GD	240
20000	20	30	3/4	30	W41220G	200	W41220GD	250
25000	20	37.5	3/4	45	W41225J	285	W41225JD	350
30000	20	45	1	45	W41230J	285	W41230JD	350
40000	20	60	1 1/2	60	W41240J	335	W41240JD	405
50000	20	75	2	95	W41250J	385	W41250JD	460
2000	30	3	1/2	15	W4132J	180	W4132JD	250
4000	30	6	1/2	15	W4134J	180	W4134JD	250
6000	30	9	1/2	15	W4136J	180	W4136JD	250
8000	30	12	1/2	15	W4138J	180	W4138JD	250
10000	30	15	3/4	15	W41310J	185	W41310JD	250
15000	30	22.5	1	30	W41315J	230	W41315JD	300
20000	30	30	1	30	W41320J	230	W41320JD	300
25000	30	37.5	1	45	W41325J	285	W41325JD	350
30000	30	45	1 1/2	45	W41330J	290	W41330JD	355
40000	30	60	2	60	W41340J	340	W41340JD	410
50000	30	75	3	95	W41350J	395	W41350JD	470
2000	40	3	1	15	W4142J	190	W4142JD	270
4000	40	6	1	15	W4144J	190	W4144JD	270
6000	40	9	1	15	W4146J	190	W4146JD	270
8000	40	12	1	15	W4148J	190	W4148JD	270
10000	40	15	1	15	W41410J	190	W41410JD	270
15000	40	22.5	1 1/2	30	W41415J	240	W41415JD	310
20000	40	30	1 1/2	30	W41420J	240	W41420JD	310
25000	40	37.5	1 1/2	45	W41425J	290	W41425JD	355
30000	40	45	2	45	W41430J	295	W41430JD	360
40000	40	60	2	60	W41440J	240	W41440JD	410
50000	40	75	3	95	W41450J	395	W41450JD	470
2000	50	3	2	15	W4152J	195	W4152JD	275
4000	50	6	2	15	W4154J	195	W4154JD	275
6000	50	9	2	15	W4156J	195	W4156JD	275
8000	50	12	2	15	W4158J	195	W4158JD	275
10000	50	15	2	15	W41510J	195	W41510JD	275
15000	50	22.5	2	30	W41515J	245	W41515JD	320
20000	50	30	3	30	W41520J	255	W41520JD	330
25000	50	37.5	3	45	W41525J	305	W41525JD	385
30000	50	45	3	45	W41530J	305	W41530JD	385
40000	50	60	5	60	W41540J	370	W41540JD	500
50000	50	75	5	95	W41550J	430	W41550JD	500

Notes: 1) EDR = Square Feet of Equivalent Direct Radiation
2) Capacity of Steam (lbs/hr) = EDR x 0.25

ELECTRIC PUMPS

W4200

Electric Condensate Pump with Cast Iron Receiver

PUMPS

CAPACITIES

EDR	Discharge Pressure (PSIG)	Flow Rate (GPM)	Motor HP	Receiver Capacity (gallons)	Simplex Model #	Weight (lbs)	Duplex Model #	Weight (lbs)
2000	20	3	1/3	6	W4222G	150	N/A	N/A
4000	20	6	1/3	6	W4224G	150	N/A	N/A
6000	20	9	1/3	15	W4226G	260	W4226GD	295
8000	20	12	1/3	15	W4228G	260	W4228GD	295
10000	20	15	1/2	15	W42210G	260	W42210GD	295
15000	20	22.5	1/2	24	W42215G	300	W42215GD	335
20000	20	30	3/4	36	W42220G	410	W42220GD	445
25000	20	37.5	3/4	36	W42225J	350	W42225JD	420
30000	20	45	1	36	W42230J	355	W42230JD	430
40000	20	60	1 1/2	50	W42240J	420	W42240JD	500
50000	20	75	2	50	W42250J	425	W42250JD	510
2000	30	3	1/2	6	W4232J	165	N/A	N/A
4000	30	6	1/2	6	W4234J	165	N/A	N/A
6000	30	9	1/2	15	W4236J	295	W4236JD	360
8000	30	12	1/2	15	W4238J	295	W4238JD	360
10000	30	15	3/4	15	W42310J	300	W42310JD	365
15000	30	22.5	1	24	W42315J	305	W42315JD	380
20000	30	30	1	36	W42320J	355	W42320JD	430
25000	30	37.5	1	36	W42325J	355	W42325JD	430
30000	30	45	1 1/2	36	W42330J	360	W42330JD	440
40000	30	60	2	50	W42340J	425	W42340JD	510
50000	30	75	3	50	W42350J	435	W42350JD	525
2000	40	3	1	6	W4242J	170	N/A	N/A
4000	40	6	1	6	W4244J	170	N/A	N/A
6000	40	9	1	15	W4246J	295	W4246JD	360
8000	40	12	1	15	W4248J	295	W4248JD	360
10000	40	15	1	15	W42410J	295	W42410JD	360
15000	40	22.5	1 1/2	24	W42415J	310	W42415JD	390
20000	40	30	1 1/2	36	W42420J	360	W42420JD	440
25000	40	37.5	1 1/2	36	W42425J	360	W42425JD	440
30000	40	45	2	36	W42430J	365	W42430JD	450
40000	40	60	2	50	W42440J	425	W42440JD	510
50000	40	75	3	50	W42450J	435	W42450JD	525
2000	50	3	2	6	W4252J	175	N/A	N/A
4000	50	6	2	6	W4254J	175	N/A	N/A
6000	50	9	2	15	W4256J	315	W4256JD	395
8000	50	12	2	15	W4258J	315	W4258JD	395
10000	50	15	2	15	W42510J	315	W42510JD	395
15000	50	22.5	2	24	W42515J	330	W42515JD	415
20000	50	30	3	36	W42520J	370	W42520JD	460
25000	50	37.5	3	36	W42525J	370	W42525JD	460
30000	50	45	3	36	W42530J	370	W42530JD	460
40000	50	60	5	50	W42540J	445	W42540JD	535
50000	50	75	5	50	W42550J	445	W42550JD	535

Notes: 1) EDR = Square Feet of Equivalent Direct Radiation

2) Capacity of Steam (lbs/hr) = EDR x 0.25

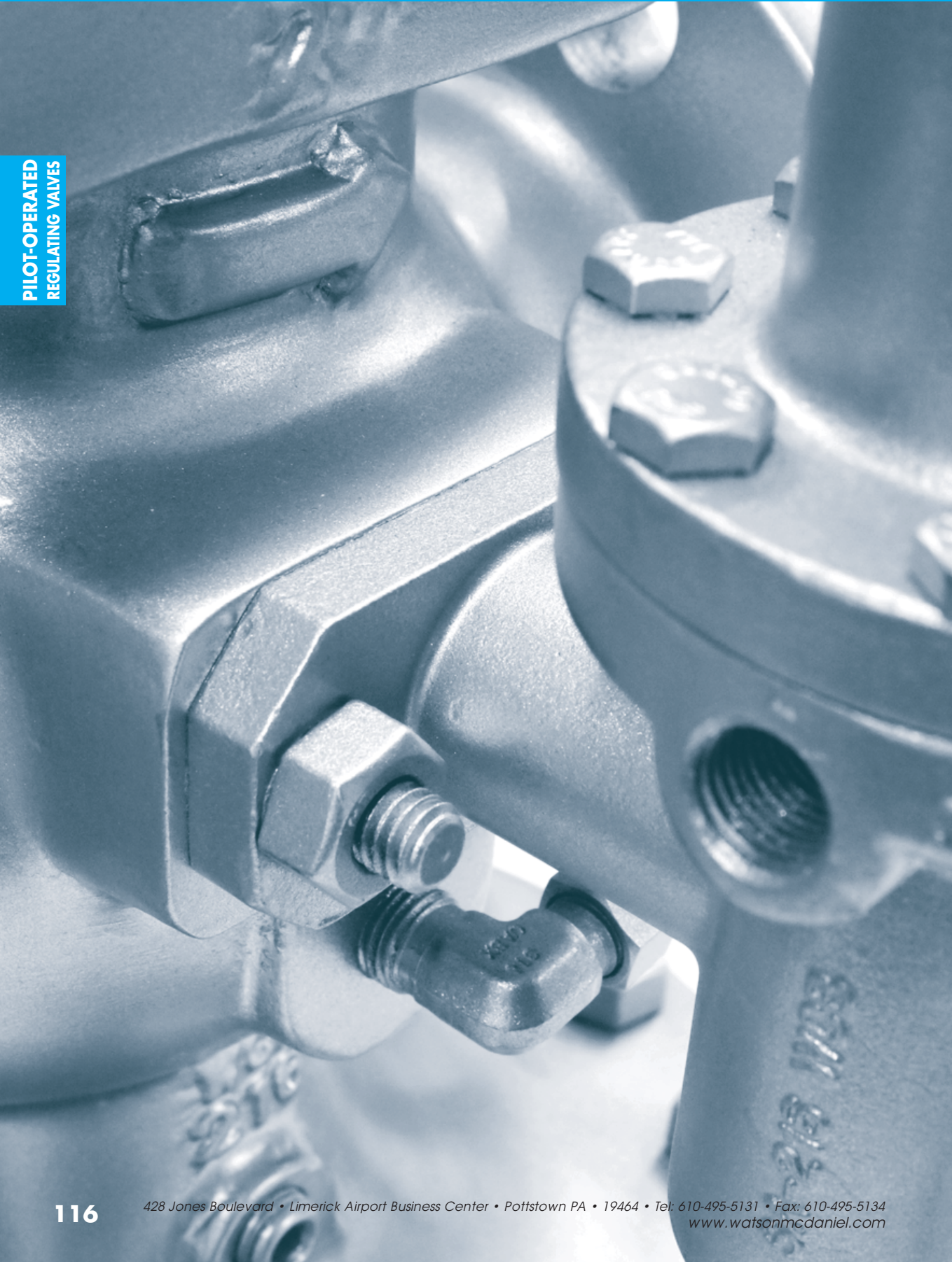

Pilot-Operated Regulating Valves

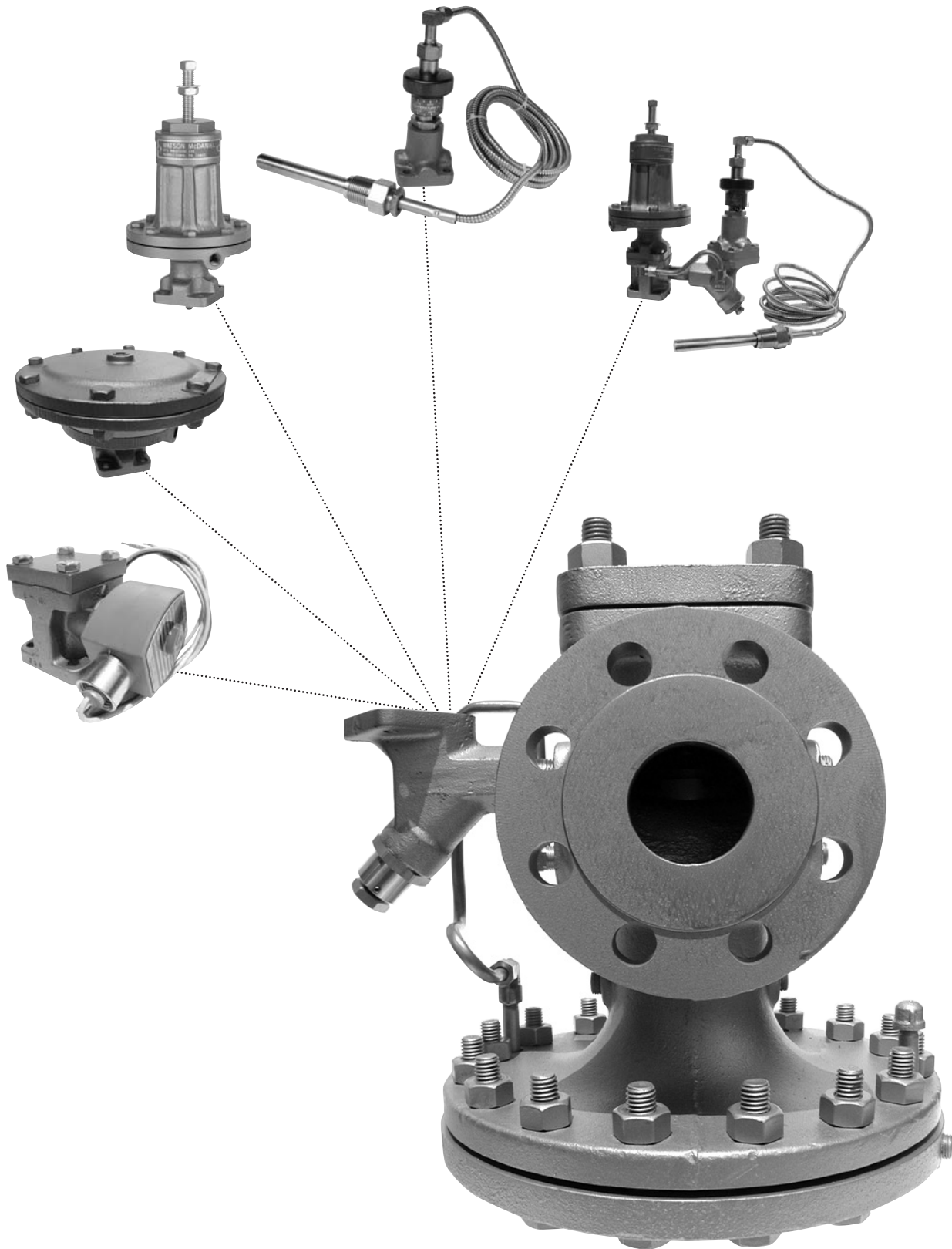

PILOT-OPERATED
REGULATING VALVES

HD Series Pilot-Operated Regulators

PILOT-OPERATED REGULATORS

Pilot-Operated Regulators are more accurate and offer higher capacities than standard direct-operated regulators. They will maintain constant set outlet pressure even when inlet pressure fluctuates or variations in flow occur. With the proper selection of pilots, these regulators will accurately control temperature, pressure, or a combination of both.

HD-Series Steam Service The HD-Series Regulator features **Ductile Iron** construction for increased pressure & temperature rating, a large full-port strainer with blow-down valve on pilot adapter which keeps dirt from entering control pilots, and field reversible pilot-mounting for versatile and easy installation.

PILOT-OPERATED REGULATING VALVES

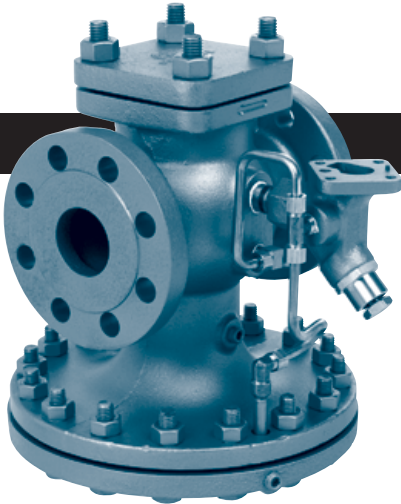

Page No.

HD Series Pilot-Operated Regulating Valve

120-123

DUCTILE IRON BODY

HD Regulators are used in conjunction with the appropriate Pilot(s) to control Steam Pressure or Process Temperature

PILOTS for HD Regulators

124-135



"P" & "P5"

Pressure Pilots - The "P" is the standard spring-loaded pressure pilot. The "P5" is used for special applications requiring 0.5 PSI accuracy.

124



"BP"

Back Pressure Pilot - Controls system back pressure.

125



"T"

Temperature Pilot - Used for controlling temperature.

126-127



"A"

Air Pilot - Normally used for controlling steam pressure using an air signal. Also used for temperature control when used in conjunction with the "PTR" or "PTL" temperature controller.

128-129

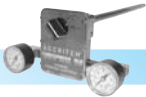

"PTR" & "PTL"

Temperature Controllers (used with "A" Air Pilot) - The "PTR" or "PTL" will control a wider temperature range than the standard "T" Pilot.

130-131



"TRP"

Temperature Pilot - Special purpose temperature pilot for controlling low temperatures outside the range of the standard "T" Pilot. Also available with special sensing bulbs.

132



"S"

Solenoid Pilot - Used in conjunction with any of the above pilots for electrical on/off control of HD Regulators.

133



"DP"

DP Pilot - Differential Pressure pilot – used when trying to balance two different media sources that are being blended

134

Over Pressure Protection Methods

135

HD Series Regulators (with commonly used Pilots)

136-143



HDP

Pressure Regulator

136-137

(HD Regulator with "P" Pressure Pilot)



HDT

Temperature Regulator

138-139

(HD Regulator with "T" Temperature Pilot)



HDA

Air Controlled Pressure Regulator

140-141

(HD Regulator with "A" Air Pilot)



HDPT

Pressure & Temperature Regulator

142-143

(HD Regulator with "P" Pressure & "T" Temperature Pilot)

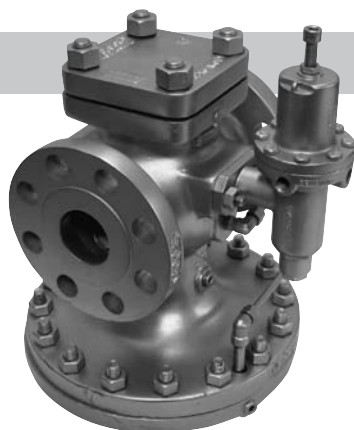

HSP Series Pilot-Operated Pressure Regulating Valve

CAST STEEL BODY

144-145

The Watson McDaniel HSP Pilot-operated Regulating Valve is constructed of Cast Carbon Steel for higher pressure & temperature ratings.

Noise Attenuators for Pressure Regulators – Series A, H & S

146-149

Capacities for Sizing of HD & HSP Series Regulators

150-151

REGULATORS

HD Series

Pilot-Operated Regulating Valve

Ductile Iron

Model	HD-Series
Sizes	1/2" - 6"
Connections	Threaded 1/2" - 2" Flanged 150# 1" - 6" Flanged 300# 1" - 6"
Body Material	Ductile Iron
PMO Max. Operating Pressure	300 PSIG
Design Pressure/	NPT 450 PSIG @ 650° F
Temperature Ratings	150# FLG 150 PSIG @ 566° F
TMA/PMA	300# FLG 450 PSIG @ 650° F

PILOT-OPERATED
REGULATING VALVES

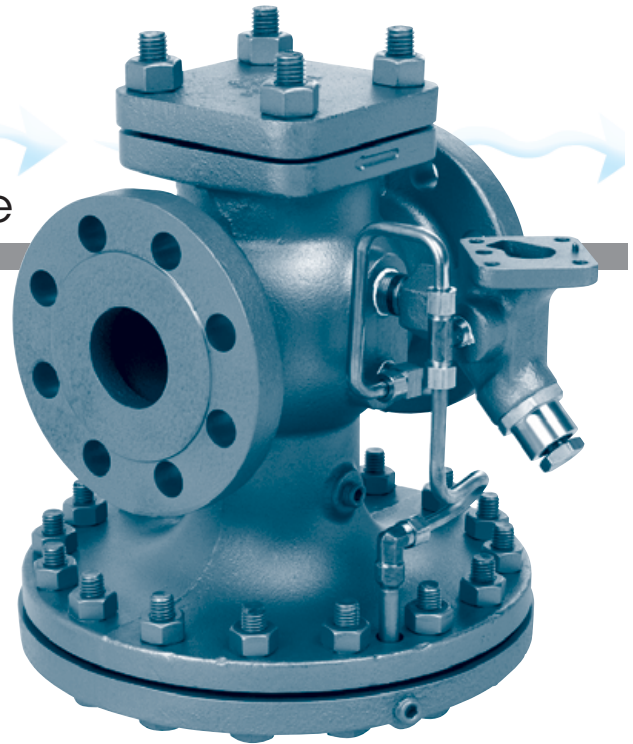

TYPICAL APPLICATIONS

The Watson McDaniel **HD-Series** pilot operated regulators were designed for **extremely accurate control of temperature and pressure** in steam service applications. The **HD-Series** is made of **Ductile-iron** for extended pressure and temperature ratings. These regulators use several different control pilots, which can be attached to the valve to control pressure, temperature, or a combination of both. The different control pilots can be added or removed from the regulator body. This modular design adds to the versatility of this product. The most common options include the **P-Pilot** for pressure reducing, and the **T-Pilot** for temperature control.

- Ductile Iron body for higher pressures
- Full port strainer & blowdown valve on pilot adapter for ultimate protection from dirt & scale
- Hardened stainless steel trim for extended life
- Pre-mounted tubing & field reversible pilot adapter
- Optional reduced port trim
- Low differential pressure option
- Low inlet pressure option

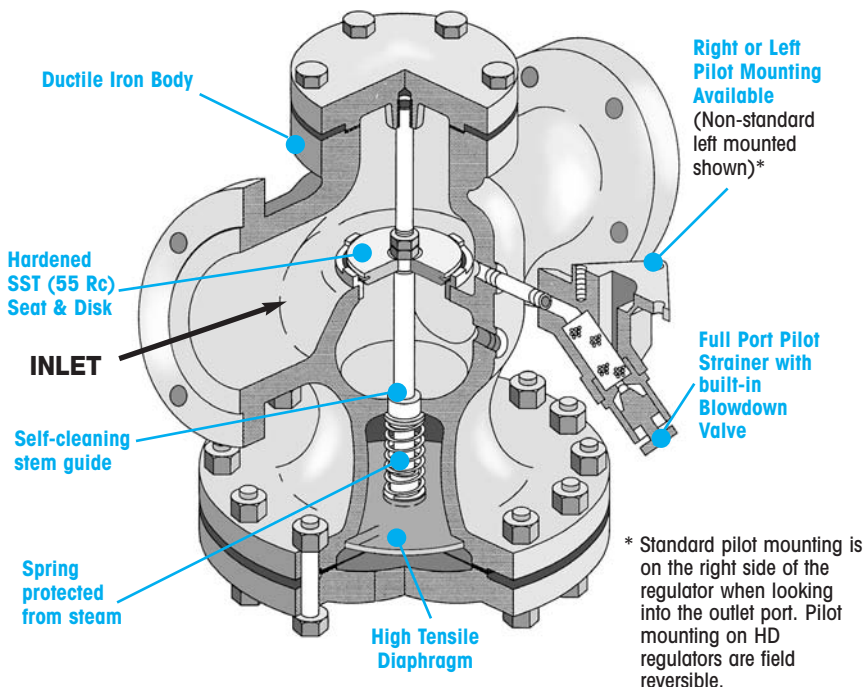

FEATURES

- No external power source is required. This simplifies the valve and minimizes installation and maintenance costs.
- Pressure and temperature pilots can be used in combination eliminating the need for a separate pressure and temperature regulator
- Ductile iron for higher pressure ranges and increased safety. Ductile Iron is a better choice than cast iron for steam applications.
- Full port strainer and blowdown valve on pilot adapter for ultimate protection against dirt and scale
- Hardened stainless steel trim (55 Rc) for extended life even in the most demanding applications
- The innovative design allows the pilot to be mounted on either side of the regulator and is easily field reversible
- Comes fully assembled with tubing and pilot adapter. The control pilot requires only four bolts to complete the installation.

Watson McDaniel reserves the right to change the designs and/or materials of its products without notice.
©2010 Watson McDaniel Company

TYPICAL PILOTS



**PRESSURE
Pilot**



**AIR
Pilot**



**TEMPERATURE
Pilot**



**SOLENOID
Pilot**

TYPICAL APPLICATIONS

- Pressure Regulating
- Temperature Regulating
- Pressure-Temperature Control
- Back Pressure Control
- Differential Pressure Control

CONTROL PILOTS

Pilot Mounting

Standard pilot mounting is on the right side of the regulator when looking into the outlet port (see diagrams on next page which are all right mounted). For opposite mounting, please specify when ordering. Pilot mounting on HD regulators are field reversible.

Pressure

When controlling pressure there are several options you can use for a pilot. The **P**-Pilot and the **P5**-Pilot are both **spring adjusted** pressure pilots. The **P**-Pilot is used on typical general-purpose pressure reducing applications. The **P5**-Pilot is used when higher accuracy is required and is capable of maintaining a control pressure window of less than 1 PSI. The **A**-Pilot is air controlled and generally used when adjustment of the regulator and pressure reducing station is done remotely.

Temperature

The **T**-Pilot is used to control temperature. The **T**-Pilot is filled with a temperature sensitive liquid, which expands when heated. The expansion of this liquid actuates a bellows that controls the temperature-regulating valve. The **T**-Pilot is equipped with an overheat bellows that protects the pilot in case of an over temperature condition. The **T**-Pilot controls temperature through a range of **60-260°F**. Spec: ANSI/FCI 70-2 Class IV shut-off.

On-Off

On-off control of the regulator is possible by using the **S**-Solenoid Pilot. The **S**-Pilot allows the regulator to be shut off or turned on **electrically**. Normally the regulator is equipped with either a **P**-Pressure Pilot or **T**-Temperature Pilot in addition to the **S**-Solenoid Pilot.

Pressure-Temperature

The **PT**-Pilot combination is used when it is desirable to control both the **pressure** and **temperature** of a system with only one regulating valve. The unique features of this modular valve allow this to be accomplished quite easily. When the **PT**-Pilot combination is used, the downstream pressure is limited to a maximum setting by the pressure pilot, while the temperature pilot maintains the correct temperature.

Back Pressure

When controlling the back pressure in a steam system, the **BP**-Pilot is used in conjunction with the **HD-Series** Regulator. This controls the pressure on the upstream side of the regulator.

Differential Pressure

The **DP**-Pilot is used when trying to balance two different media sources that are being blended.

COMBINATION PILOTS

One of the advantages of the **HD-Series** regulating valve is that it can be used with many different variations of control pilots. Up to three pilots can be used simultaneously to control the operation of these valves. The most common is the "PT" Pressure-Temperature combination pilots. In addition to these pilots being used together the **S**-Solenoid Pilot can be used for turning the system on and off. (See next page for combination examples.)

REGULATORS

HD Series

Pilot-Operated Regulating Valve

Watson McDaniel reserves the right to change the designs and/or materials of its products without notice.
©2010 Watson McDaniel Company

TYPICAL REGULATOR & PILOT COMBINATIONS

PILOT-OPERATED
REGULATING VALVES

HDA
Regulator
with
Air Pilot

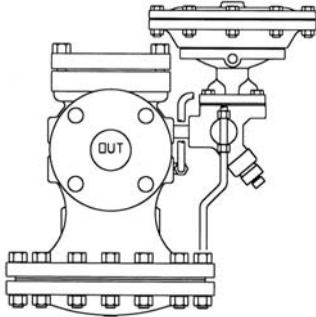

HDP
Regulator
with
Pressure Pilot

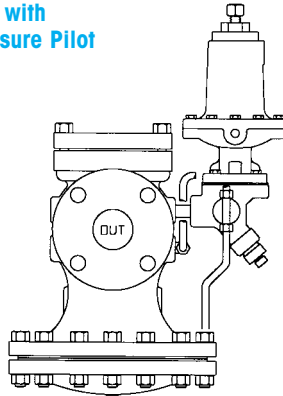

HDT
Regulator
with
Temperature
Pilot

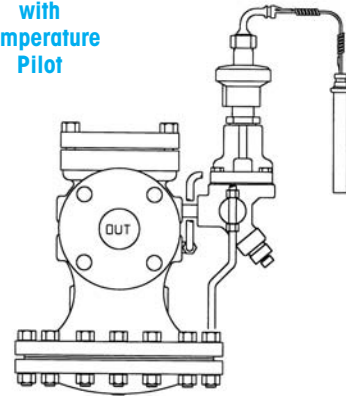

HDS
Regulator
with
Solenoid Pilot

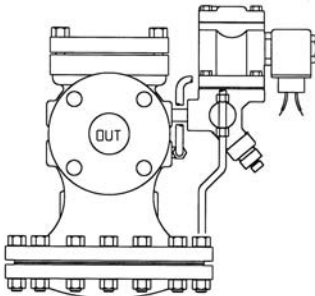

HDPS
Regulator
with
Pressure & Solenoid
Pilots

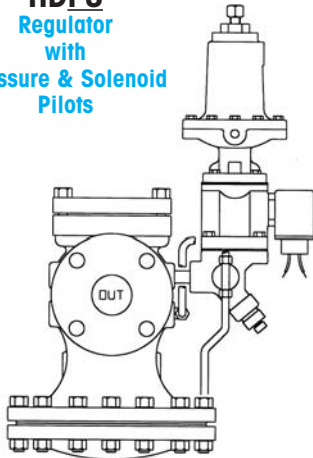

HDTS
Regulator
with
Temperature &
Solenoid Pilots

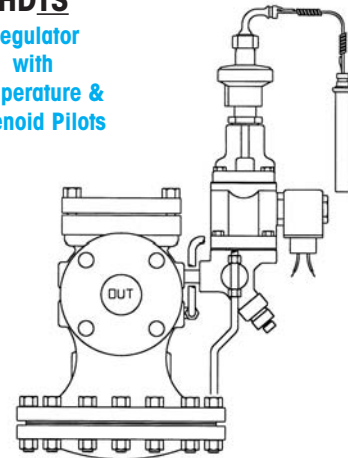

HDPT
Regulator
with
Pressure &
Temperature
Pilots

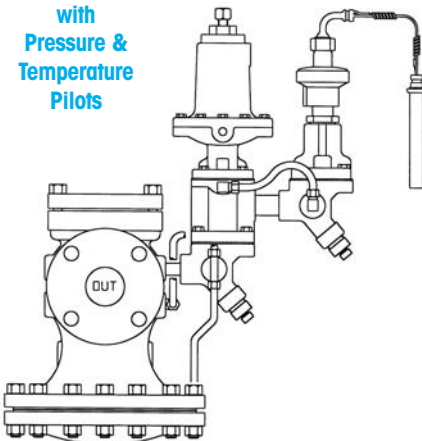

HDPTS
Regulator
with
Pressure,
Temperature &
Solenoid Pilots

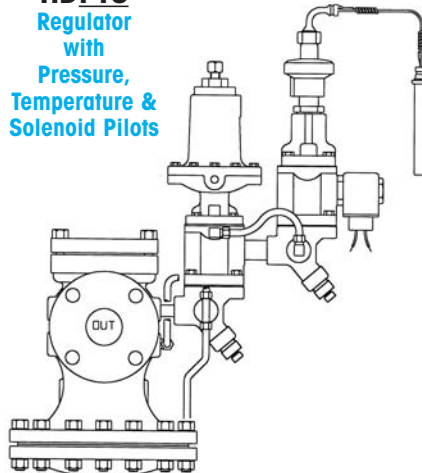

OTHER PILOT CONFIGURATIONS USED WITH HD REGULATOR

- Air / Solenoid
- Air / Pneumatic Temperature Controller
- Air / Solenoid / Pneumatic Temperature Controller
- Back Pressure
- Back Pressure / Solenoid
- Differential Pressure

*Watson McDaniel's Pilots will fit other
Manufacturers' Regulators.*

HD Series

Pilot-Operated Regulating Valves

HD-Series DIMENSIONS – inches / pounds

Size	(A) Face-To-Face			B	C	D	Weight (lbs)		
	NPT	150#	300#				NPT	150#	300#
1/2"	4 ³ / ₈			5 ¹ / ₂	3 ³ / ₈	6 ¹ / ₂	18		
3/4"	4 ³ / ₈			5 ¹ / ₂	3 ³ / ₈	6 ¹ / ₂	18		
1"	5 ³ / ₈	5 ¹ / ₂	6	6 ¹ / ₄	3 ¹ / ₂	7	23	40	45
1 ¹ / ₄ "	6 ¹ / ₂			7 ³ / ₈	4 ⁷ / ₈	8 ³ / ₄	43		
1 ¹ / ₂ "	7 ¹ / ₄	6 ⁷ / ₈	7 ³ / ₈	7 ³ / ₈	4 ⁷ / ₈	8 ³ / ₄	43	55	60
2"	7 ¹ / ₂	8 ¹ / ₂	9	8 ¹ / ₄	5 ³ / ₈	10 ⁷ / ₈	65	75	85
2 ¹ / ₂ "		9 ³ / ₈	10	9	5 ³ / ₄	11 ³ / ₄		100	105
3"		10	10 ³ / ₄	8 ⁷ / ₈	6 ³ / ₄	13 ¹ / ₄		130	145
4"		11 ⁷ / ₈	12 ¹ / ₂	10 ⁷ / ₈	7 ¹ / ₂	14 ³ / ₄		215	235
6"		15 ¹ / ₈	16	14 ¹ / ₈	10	19 ³ / ₄		420	470

Option: Stainless diaphragms and external tubing - consult factory

MATERIALS

Body	Ductile Iron
Cover	Ductile Iron
Gasket	Grafoil
Cover Screws	Steel
Pilot Adapter	Ductile Iron/Cast Steel
Screen	Stainless Steel
Tubing	Copper
Valve Seat	Hardened SST (55Rc)
Valve Disc	Hardened SST (55Rc)
Diaphragm	Phosphor Bronze

MINIMUM OPERATING PRESSURES

Minimum Inlet Pressure (for Valve):
15 PSIG (Standard Main Valve)
5 PSIG (Low Pressure Main Valve)

Minimum Differential Pressure (for Valve):*
10 PSI (Standard Main Valve)
3 PSI (Low Pressure Main Valve)

* Not required for Temperature Pilot applications

PILOT-OPERATED
REGULATING VALVES

HOW TO ORDER

REGULATOR BODY

Specify: • **HD** regulator body
 • Regulator size or capacity of steam required
 • End connections
 (threaded, 150/300# flanged)

PILOT REQUIRED TO OPERATE THIS VALVE

Note: See "How to Order" in specific Pilot Section

- **T** Temperature Pilot
- **P** Pressure Pilot
- **A** Air Pilot
- **S** Solenoid Pilot
- **BP** Back Pressure Pilot
- **PD** Differential Pressure

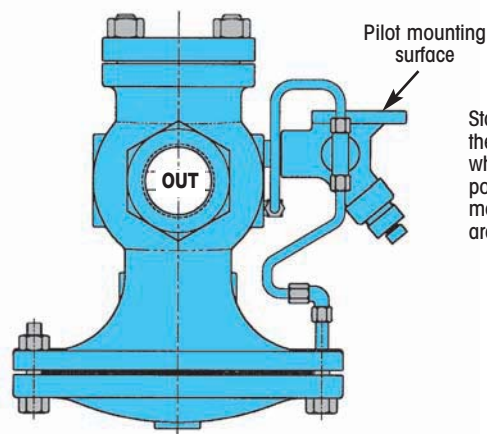
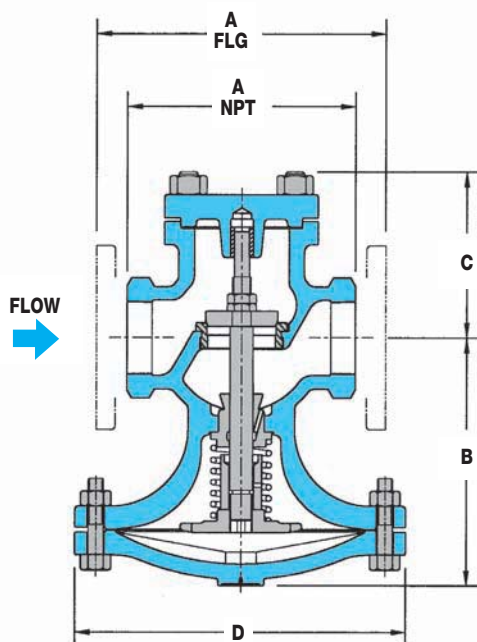

Standard pilot mounting is on the right side of the regulator when looking into the outlet port (as shown). Pilot mounting on HD regulators are field reversible.

"P" & "P5" Pilot

Watson McDaniel reserves the right to change the designs and/or materials of its products without notice.
©2010 Watson McDaniel Company

Pressure Pilot for HD Regulating Valves

PILOT-OPERATED REGULATING VALVES

Pressure Pilot

- **Max Inlet Pressure: 300 PSIG**
- **Reduced Outlet Pressure Range: 3-200 PSIG**
- **Minimum Inlet Pressures:**
 - 15 PSIG when used with standard main valve
 - 5 PSIG when used with low pressure main valve
- **P-Pilot** (Standard) ± 1 PSIG accuracy
- **P5-Pilot** (Special) ± 0.5 PSIG accuracy



PRESSURE-ADJUSTING SPRING RANGES

"P" Pressure Range	"P5" Pressure Range	Identifying Colors
3-25 PSIG	1-10 PSIG	yellow
20-100 PSIG	10-25 PSIG	blue
80-200 PSIG	-	red

MATERIALS

Pilot Body & Cover	Ductile Iron or Cast Steel
Gasket	Grafoil
Diaphragm	Phosphor Bronze
Head & Seat Assembly	Hardened SST (55 Rc)

TYPICAL APPLICATIONS

The "P" & "P5" Pressure Pilots are used with the HD Regulator to control steam pressure in steam mains or for process equipment. Pilot operated regulators will maintain constant downstream pressure even when the inlet pressure to the valve fluctuates or steam usage varies.

FEATURES

- The "P" Pilot can maintain downstream pressure to ± 1 PSIG
- "P5" Pilot can maintain downstream pressure to ± 0.5 PSIG
- Choices of three overlapping pressure ranges
- Pressure control spring can be changed in line
- Pilot is easily installed using only four bolts
- Full port strainer and blowdown valve on pilot adapter for ultimate protection from dirt and scale
- Can be used with temperature and solenoid control pilot
- Solid floating diaphragm is more failure resistant
- Watson McDaniel's pilots can be used with other manufacturers' regulators

OPTIONS

- Pressure pilot can be used with temperature pilot to eliminate the need for two separate regulators
- Solenoid pilot can be added for remote on/off control of regulator
- "P5" Pilot will maintain ± 0.5 PSIG accuracy

MINIMUM OPERATING PRESSURES

Minimum Inlet Pressure:

- 15 PSIG (Standard Main Valve)
- 5 PSIG (Low Pressure Main Valve)

Minimum Differential Pressure:

- 10 PSI (Standard Main Valve)
- 3 PSI (Low Pressure Main Valve)

HOW TO ORDER

"P", "P5" PRESSURE PILOT

Specify: • Reduced pressure range –

Example: "P" Pilot at 3-25 PSIG, yellow

REGULATOR BODY

Specify: • HD regulator body
• Regulator size or capacity
• End connections (threaded, 150/300# flanged)

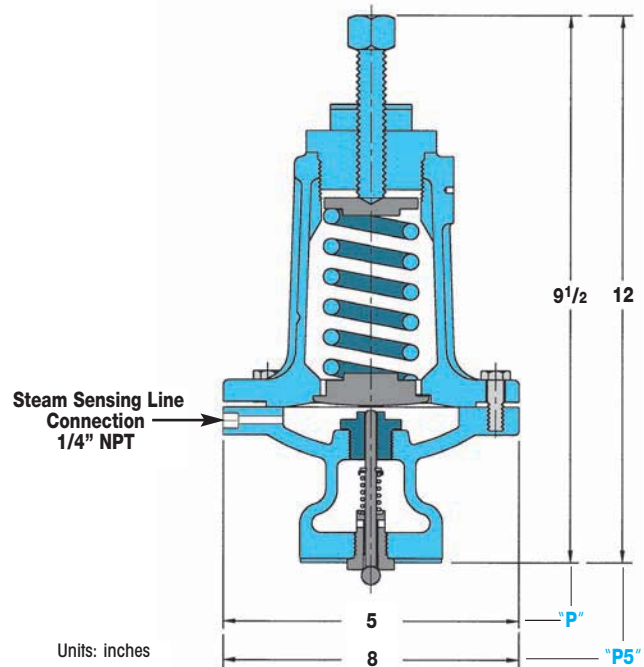

"BP" Pilot

Back Pressure Pilot for HD Regulating Valves

Back Pressure Pilot

- **Max Inlet Pressure: 300 PSIG**
- **Back Pressure Range: 10-200 PSIG**
- **Minimum Inlet Pressures:**
 - 15 PSIG when used with standard main valve
 - 5 PSIG when used with low pressure main valve



PILOT-OPERATED REGULATING VALVES

PRESSURE-ADJUSTING SPRING RANGES

Pressure Range	Identifying Colors
10-25 PSIG	yellow
20-100 PSIG	blue
80-200 PSIG	red

MATERIALS

Pilot Body & Cover	Ductile Iron
Gasket	Grafoil
Diaphragm	Phosphor Bronze
Head & Seat Assembly	Hardened SST (55 Rc)

TYPICAL APPLICATIONS

The "BP" Back-Pressure Pilot used with the HD regulator, maintains upstream pressure in steam systems. These regulators are commonly used to supply flash steam to low pressure mains.

FEATURES

- The "BP" Pilot can maintain upstream pressure to ± 1 PSIG
- Choices of three overlapping pressure ranges
- Pressure adjusting spring can be changed with regulator in line
- Pilot is easily installed using only four bolts
- Full port strainer and blowdown valve on pilot adapter for ultimate protection from dirt and scale
- Solid floating diaphragm is more failure resistant
- Watson McDaniel's pilots can be used with other manufacturers' regulators

OPTIONS

- Can be used with solenoid pilot for on/off control

MINIMUM OPERATING PRESSURES

Minimum Inlet Pressure:

- 15 PSIG (Standard Main Valve)
- 5 PSIG (Low Pressure Main Valve)

Minimum Differential Pressure:

- 10 PSI (Standard Main Valve)
- 3 PSI (Low Pressure Main Valve)

HOW TO ORDER

"BP" BACK PRESSURE PILOT

- Specify: • Reduced pressure range –
 Example: "BP" Pilot at 20-100 PSIG, blue

REGULATOR BODY

- Specify: • HD regulator body
 • Regulator size or capacity
 • End connections (threaded, 150/300# flanged)

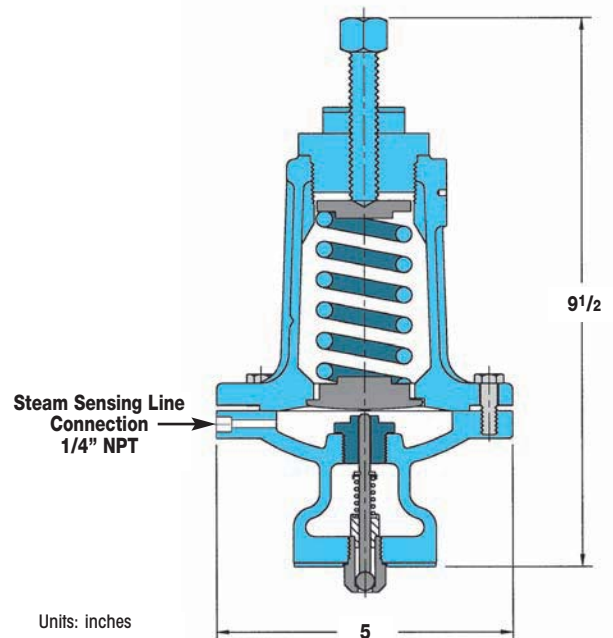

"T" Pilot

Watson McDaniel reserves the right to change the designs and/or materials of its products without notice.
©2010 Watson McDaniel Company

Temperature Pilot for HD Regulating Valves

PILOT-OPERATED REGULATING VALVES

Temperature Pilot

- **Max Inlet Pressure: 300 PSIG**
- **Temperature Control Range: 60-260 °F**
- **Minimum Inlet Pressures:**
 - 15 PSIG** when used with standard main valve
 - 5 PSIG** when low pressure temperature pilot is used with low pressure main valve

Low Pressure Temperature Pilot must be used in conjunction with a low pressure main valve for applications where inlet steam pressure is less than 15 PSIG. SPECIFY WHEN ORDERING.



TYPICAL APPLICATIONS

The "T" Temperature Pilot is used with the HD regulator to control temperature in various processes and systems. Some examples are:

- Oil heaters
- Process heaters
- Dryers
- Ovens
- Vats
- Jacketed Kettles

FEATURES

- Temperature adjustment made simple and easy by rotating an adjustment knob to the desired temperature setting
- Thermostatic sensing bulb comes with an 8-ft. or 15-ft. length capillary
- Capillary is armor-protected to resist damage
- Overheat protection bellows is incorporated into sensing bulb; 200°F overheat protection up to 350°F
- Full port strainer and blowdown valve on pilot adapter for ultimate protection from dirt and scale

OPTIONS

- Temperature Pilot can be combined with Pressure and Solenoid pilots
- Additional capillary lengths can be ordered in 5-ft. increments; up to 25-ft. maximum length
- Wells* for isolating sensing bulb from process liquid are available in 316 stainless steel or brass
- Extended length wells are available
- 316 Stainless Steel Sensing Bulb
- Other options available; consult factory

*** Thermowells:**

Wells isolate sensing bulb from the process liquid and are available in Brass or Stainless Steel. When placed on the side of a tank or vessel, the sensing bulb can be removed without having to drain the process fluid.

TEMPERATURE-ADJUSTING RANGES

Temperature Ranges*	Identifying Colors
60 - 120 °F (16 - 49 °C)	yellow
100 - 160 °F (38 - 71 °C)	black
120 - 180 °F (49 - 82 °C)	blue
160 - 220 °F (71 - 104 °C)	red
200 - 260°F (93 - 127 °C)	green

* Other ranges available; consult factory.

MATERIALS

Body	Ductile Iron/Cast Steel
Head & Guide	Stainless Steel
Seat	Stainless Steel
Sensing Bulb:	
T	Copper Bulb
TU	Copper Bulb w/Brass Union Hub
TUBW	Copper Bulb w/Brass Well
TUSW	Copper Bulb w/Stainless Steel Well
TBW	Copper Bulb w/Brass Well & Grommet
TSW	Copper Bulb w/Stainless Steel Well & Grommet

Pressure & Temperature Pilot combination

Controls downstream pressure and process temperature, eliminating the need for a separate pressure regulator



"T" Pilot

Temperature Pilot for HD Regulating Valves

PILOT-OPERATED REGULATING VALVES

SENSING BULBS AVAILABLE

Units: inches

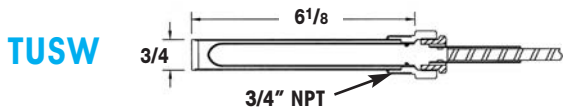
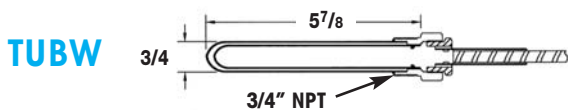
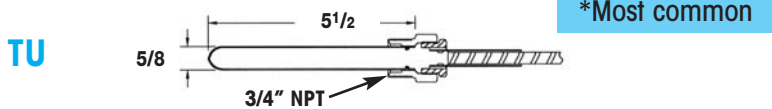
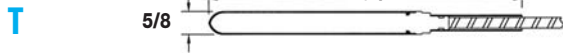
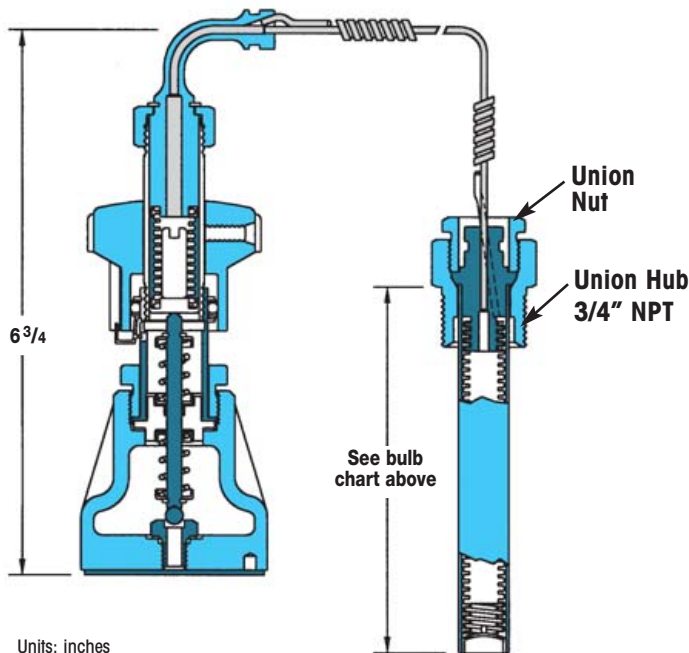

Diagram below shows "T" Pilot TU Option for Bulb



- T** Plain copper bulb
 - TU** Union connected copper bulb that can be screwed into the side of tank
* most common selection
 - TUBW** Type TU bulb with a **brass well**. The well, which isolates bulb from process fluid, can be placed in the side of a tank allowing the sensing bulb to be removed without having to drain the tank of liquid
 - TUSW** Type TU bulb with a corrosion resistant **stainless steel well**. The well, which isolates bulb from process fluid, can be placed in the side of a tank allowing the sensing bulb to be removed without having to drain the tank of liquid
 - TBW** Type T bulb with an **extended length brass well**. The extended well allows deeper insertion of sensing bulb into tanks.
 - TSW** Type T bulb with **extended length stainless steel well**. The extended well allows deeper insertion of sensing bulb into tanks.
- Other options available; consult factory.**

HOW TO ORDER

"T" TEMPERATURE PILOT

Specify:

- Temperature range from the chart or indicate the temperature of the process you wish to control
- The length of capillary required; 8-ft. is standard
- Bulb type needed:
T, TU, TUBW, TUSW, TBW & TSW

Example: **TU, 8 FT CAP, 60-120°F, yellow**

REGULATOR BODY

Specify:

- HD regulator body
- Regulator size or capacity of steam required
- End connections (threaded, 150/300# flanged)

MINIMUM OPERATING PRESSURES

Minimum Inlet Pressure:

- 15 PSIG** (Standard Main Valve)
- 5 PSIG** (Low Pressure Main Valve with Low Pressure Temperature Pilot)

Low Pressure Temperature Pilot must be used in conjunction with a Low Pressure Main Valve for applications where inlet steam pressure is below 15 PSIG. SPECIFY WHEN ORDERING.

"A" Pilot

Air Pilot for HD Regulating Valves **Controls Pressure & Temperature**

PILOT-OPERATED REGULATING VALVES

Air Pilot

- **Max Inlet Pressure: 300 PSIG**
- **Reduced Outlet Pressure Range: 3-200 PSIG**
- **Minimum Inlet Pressures:**
 - 15 PSIG** when used with standard main valve
 - 5 PSIG** when used with low pressure main valve



Note: Temperature Range: 0-350°F when used with PTL & PTR temperature controllers

TYPICAL APPLICATIONS

The "A" Air Pilot is used with the HD Regulator to control steam pressure on steam mains and process equipment. The "A" Air Pilot can also be used in conjunction with the PTL or PTR pneumatic temperature controllers for controlling temperature in process applications. The principal advantage the "A" Air Pilot over standard spring loaded pilots is that pressure adjustments to the regulator can be made from a remote location. A regulator that is placed in a difficult to reach or inaccessible location can be adjusted by a remote control panel board placed in an accessible location.

HOW IT WORKS

When air pressure is applied to the upper chamber of the air pilot it exerts a downward force on the air pilot's diaphragm. This force controls the outlet pressure of the steam through the regulating valve. The control process is similar to a spring loaded pressure pilot except that the air pressure takes the place of the spring. There are three separate models of air pilots that make up the complete range depending on the steam pressure that needs to be controlled and the control air pressure available. See Pressure Adjusting Ranges chart.

FEATURES

- **Pressure adjustments to the regulator can be done from a remote location using an air signal**
- **Air-operated pilot ensures instant response and extremely accurate control**
- **Full port strainer and blowdown valve on pilot adapter for ultimate protection from dirt and scale**
- **Controls pressure settings within ±1 PSIG**

DIMENSIONS – inches

Model	A	B
A1	5 1/4	5
A4	5 1/4	7 7/8
A6	5 1/4	9 1/2

MAXIMUM CONTROL AIR PRESSURE ON AIR PILOT IS 125 PSIG

PRESSURE ADJUSTING RANGES

Model	Pressure Ranges	Description
A1	3-125 PSIG	1:1 ratio of steam pressure to control air pressure
A4	3-200 PSIG	4:1 ratio of steam pressure to control air pressure
A6	20-200 PSIG	6:1 ratio of steam pressure to control air pressure

The larger Diaphragm area of the "A4" & "A6" Air Pilots allow the use of lower control air pressure to regulate higher pressure steam.

MATERIALS

Pilot Body & Cover	Ductile Iron
Gasket	Grafoil
Cover Screws	Steel, GR5
Head & Seat Assembly	Hardened SST (55 Rc)

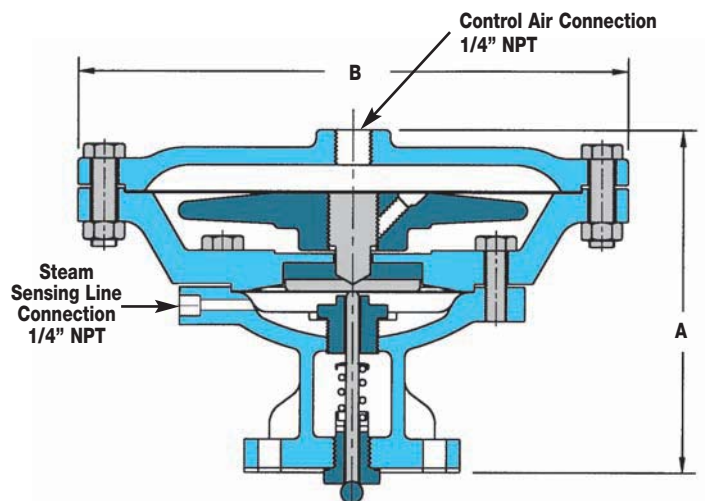

"A" Pilot

Controls Pressure & Temperature

Air Pilot for HD Regulating Valves

PILOT-OPERATED REGULATING VALVES

REMOTE CONTROL PANEL BOARDS

Three different options of remote control panel boards can be used along with the "A" Air Pilots. Supply air is fed directly through the control panel board to the air pilot. You can choose one of the three options of control panel boards when using the air piloted regulators. Minimum 5 PSIG air supply pressure is required.



PL1

PL1

The **PL1** is made up of an air pressure regulator with adjustment knob and pressure gauge that measures the amount of air pressure going to the pilot (air signal). Steam pressure of the system is controlled by adjusting the air pressure regulator.



PL2

PL2

The **PL2** is the same as the PL1 with the addition of an extra air pressure gauge for measuring the air supply pressure to the control panel board.



PL3

PL3

The **PL3** is the same as the PL2 with the addition of a Steam Pressure Gauge for measuring steam pressure on the outlet side of the regulating valve.

HOW TO ORDER

"A" AIR PILOT

Specify:

- Air Pilot **A1**, **A4** or **A6**
- Remote Control Panel Board **PL1**, **PL2** or **PL3**

REGULATOR BODY

Specify:

- **HD** regulator body
- Regulator size or capacity and pressure range of steam required
- End connections (threaded, 150/300# flanged)

MINIMUM OPERATING PRESSURES

Minimum Inlet Pressure:

- 15 PSIG** (Standard Main Valve)
- 5 PSIG** (Low Pressure Main Valve)

Minimum Differential Pressure:

- 10 PSI** (Standard Main Valve)
- 3 PSI** (Low Pressure Main Valve)

CONTROL AIR PRESSURE RANGE

A-Pilot Control Pressure:

- 3-125 PSIG** (depending on pilot selected and desired outlet pressure)

Pressure Reducing Station Using HD Regulator with an Air Pilot

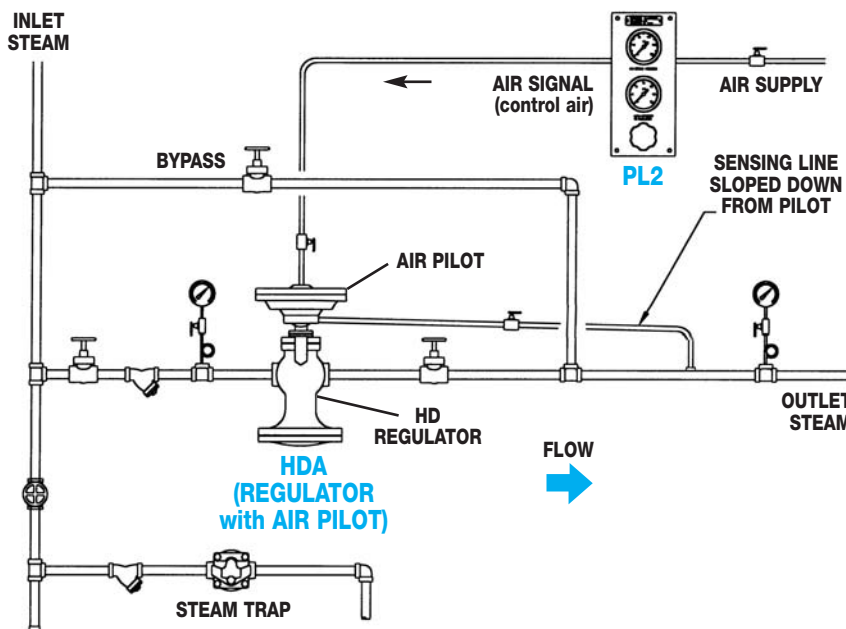

DESCRIPTION OF OPERATION

The "A" Air Pilot is being used in conjunction with the **PL2 Control Panel Board** to regulate steam pressure. A small air regulator on the panel board can be adjusted to control the air pressure to the pilot. One gauge on the panel board measures air line pressure to the panel board and the other gauge shows the air pressure being sent to the pilot. Steam pressure at the outlet of the regulator is controlled by the air pressure signal to the pilot. Depending on the air pilot model chosen (**A1**, **A4**, **A6**), there will be a 1:1, 4:1, or 6:1 ratio of outlet steam pressure to air pressure.

PTL & PTR Controller

Pneumatic Temperature Controller (used with Air Pilot)

Watson McDaniel reserves the right to change the designs and/or materials of its products without notice.
©2010 Watson McDaniel Company

PILOT-OPERATED
REGULATING VALVES

Pneumatic Temperature Controller

- Max Inlet Pressure: 300 PSIG
- Temperature Range: PTR: 0-300 °F
PTL: 50-350 °F
- Minimum Inlet Pressures:
15 PSIG when used with standard main valve
5 PSIG when used with low pressure main valve



PTL
(mounts directly on tank or vessel)



PTR
(mounts remotely with 4-ft. Capillary)

TYPICAL APPLICATIONS

The **PTL** and **PTR Pneumatic Temperature Controllers** operate over a wider temperature range than our standard "T" temperature pilot. These temperature controllers also react quicker to temperature change which make them an excellent choice for instantaneous hot water applications.

HOW IT WORKS

The **PTL** and **PTR Pneumatic Temperature Controllers** are used in conjunction with an "A" Air Pilot to control the operation of the HD Regulator. The **PTL** uses a bimetallic element to sense temperature and the **PTR** uses a hydraulically filled bulb with a 4-ft. capillary to sense temperature. The air supply is connected to the inlet of the controller and the air output signal is fed directly to an Air Pilot, which controls the opening and closing of the steam regulating valve.

FEATURES

- Accurate and rapid response to temperature changes
- Covers control temperature range of 0-350 °F

MINIMUM OPERATING PRESSURES

Minimum Inlet Pressure:

- 15 PSIG (Standard Main Valve)
- 5 PSIG (Low Pressure Main Valve)

Model	PTL	PTR
Temperature Adjustment Range	50 - 350 °F	0 - 300 °F
Maximum Air Supply Pressure	35 PSIG	35 PSIG
Sensing Bulb	Bi-Metallic	Hydraulic Fill
Max. Pressure	250 PSIG	250 PSIG
Max. Temperature	400°F	350°F
Material	Copper	Copper
Optional Material	Stainless Steel	Stainless Steel
Capillary Length	N/A	4-ft.

HOW TO ORDER

PTL & PTR PNEUMATIC TEMPERATURE CONTROLLER

Specify: • PTL or PTR controller model (air pilot required for operation)

AIR PILOT

Specify: • A1, A4 or A6 Air Pilot model (refer to Air Pilot section)

REGULATOR BODY

Specify: • HD regulator body
• Regulator size or capacity
• End connections (threaded, 150/300# flanged)

PTL & PTR Controller

Pneumatic Temperature Controller (used with Air Pilot)

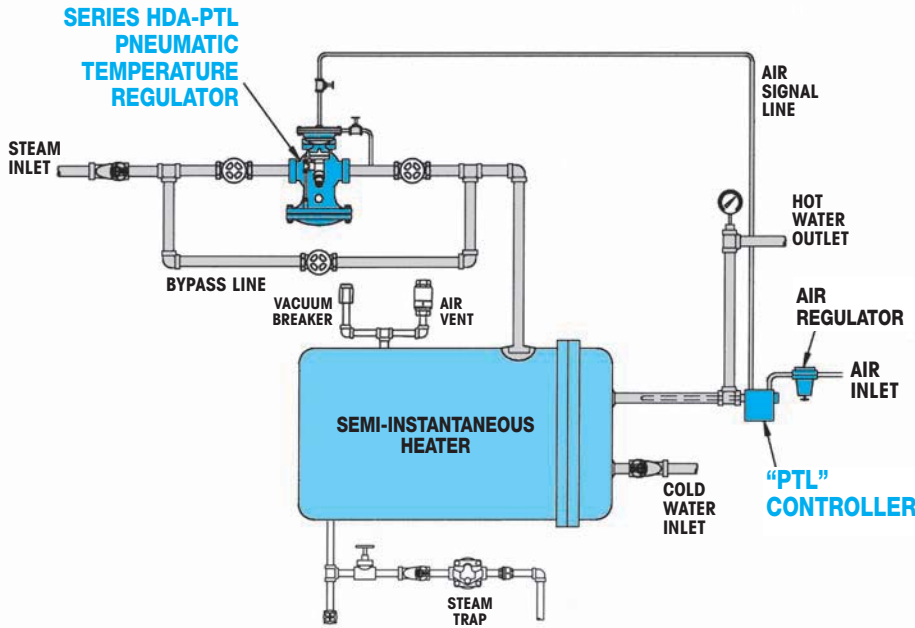

DESCRIPTION OF OPERATION

The PTL Pneumatic Temperature Controller senses outlet water temperature on a semi-instantaneous hot water heater. When the outlet water temperature falls below the set point, the PTL pneumatic temperature controller sends an air signal to the A1 Air Pilot which opens the regulator, allowing steam to heat the tank. When the water reaches the desired set temperature, the PTL pneumatic temperature controller shuts off the air signal to the A1 Air Pilot and the regulator closes, cutting off steam to the heater.

PILOT-OPERATED REGULATING VALVES

Model PTL (direct mounted)

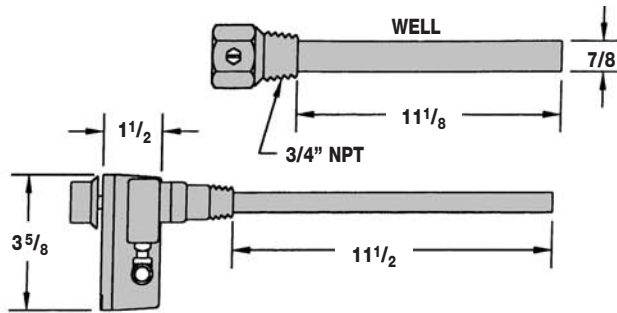

TEMPERATURE SET POINT ADJUSTMENT KNOB

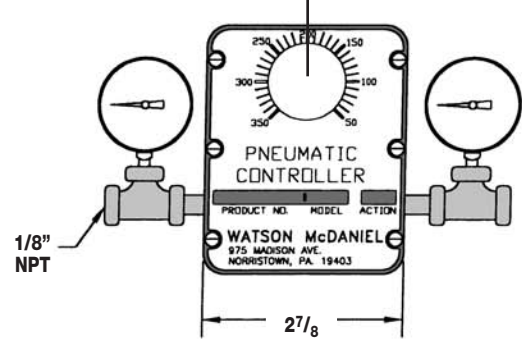

Units: inches

Model PTR (remote mounted)

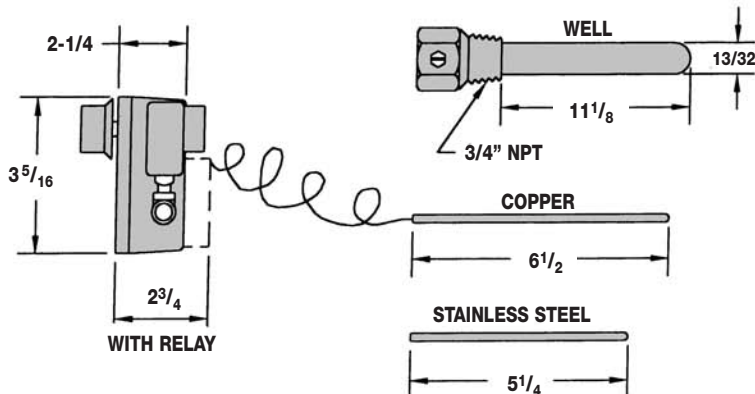

TEMPERATURE SET POINT ADJUSTMENT KNOB

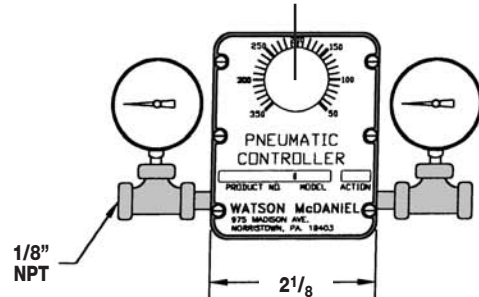

"TRP" Pilot

Temperature Pilot for HD Regulating Valves

Watson McDaniel reserves the right to change the designs and/or materials of its products without notice.
©2010 Watson McDaniel Company

PILOT-OPERATED REGULATING VALVES

Temperature Pilot

- Max Inlet Pressure: 300 PSIG
- Temperature Control Range: 20-250 °F
- Min Inlet Pressures: 15 PSIG standard main valve
5 PSIG low pressure main valve

TYPICAL APPLICATIONS

The "TRP" Temperature Pilot is used with the HD Regulator to control temperature in various processes and systems. Some examples are: Oil heaters, Ovens, Process Heaters, Vats, Dryers and Jacketed Kettles.

FEATURES

- Ductile Iron pilot body
- Stainless steel valve and seat
- Standard capillary is copper with 316 stainless steel armor in 10 feet length

OPTIONS

- **Additional Capillary Length:** Available up to 25-ft. in 5-ft. increments.
- **Special Materials:** Sensing bulb, wells, and capillary are available in special corrosion resistant materials.
 - 316 stainless steel capillary
 - 316 stainless steel armor with standard capillary
 - Kynar-covered capillary
- **Finned Bulb:** Special finned sensing bulb for improved temperature sensitivity when controlling air temperature in heating ducts
- **Thermowell or Separable Socket:** Available in stainless steel or copper
- **Temperature Sensing Dial:** Indicates temperature of process being controlled



The "TRP" will control lower temperatures than the standard "T" Pilot

MATERIALS

Pilot Body	Ductile Iron
Valve and Seat	Stainless steel
Support Bracket	Aluminum
Bulb & Capillary	Copper (optional stainless steel)
All Other Parts	Brass

HOW TO ORDER

"TRP" TEMPERATURE PILOT

Specify:

- Temperature range from the chart or indicate the temperature of the process you wish to control
- The length of capillary required

REGULATOR BODY

Specify:

- HD regulator body
- Regulator size or capacity of steam required
- End connections (threaded, 150/300# flanged)

DIMENSIONS – inches

Std. Bulb Range °F	Bulb Length A	Bulb Diameter B	Body Height C		Thermowell or Separable Socket	
			w/Dial	w/o Dial	D	E
40-65°	12 ¹ / ₄	1.0	11 ¹ / ₄	16 ¹¹ / ₆₄	13	1.1
65-85°	12 ¹ / ₄	1.0	11 ¹ / ₄	16 ¹¹ / ₆₄	13	1.1
85-110°	12 ¹ / ₄	1.0	11 ¹ / ₄	16 ¹¹ / ₆₄	13	1.1
110-135°	12 ¹ / ₄	1.0	11 ¹ / ₄	16 ¹¹ / ₆₄	13	1.1
135-160°	12 ¹ / ₄	1.0	11 ¹ / ₄	16 ¹¹ / ₆₄	13	1.1
160-190°	12 ¹ / ₄	1.0	11 ¹ / ₄	16 ¹¹ / ₆₄	13	1.1
190-210°	12 ¹ / ₄	1.0	11 ¹ / ₄	16 ¹¹ / ₆₄	13	1.1
210-245°	12 ¹ / ₄	1.0	11 ¹ / ₄	16 ¹¹ / ₆₄	13	1.1
245-275°	12 ¹ / ₄	1.0	11 ¹ / ₄	16 ¹¹ / ₆₄	13	1.1
275-310°	12 ¹ / ₄	1.0	11 ¹ / ₄	16 ¹¹ / ₆₄	13	1.1
305-365°	12 ¹ / ₄	1.0	11 ¹ / ₄	16 ¹¹ / ₆₄	13	1.1
365-415°	12 ¹ / ₄	1.0	11 ¹ / ₄	16 ¹¹ / ₆₄	13	1.1
415-435°	12 ¹ / ₄	1.0	11 ¹ / ₄	16 ¹¹ / ₆₄	13	1.1

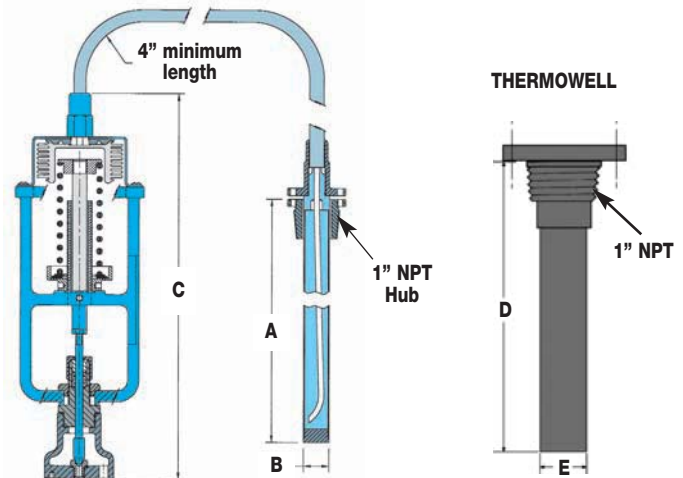

"S" Pilot

Electric Pilot for On/Off Control of HD Regulating Valves

Solenoid Pilot

- For Electrical On-Off Control of Regulating Valves
- Max Inlet Pressure: 250 PSIG

PILOT-OPERATED
REGULATING VALVES

TYPICAL APPLICATIONS

Typically used for automatic operation, remote control, programmed cycling, sequential function interlocks with other equipment, and emergency shut-off in case of power failure.

HOW IT WORKS

The **"S" Solenoid Pilot** can be used in conjunction with Pressure, Temperature, or Air Pilots to electrically control on/off operation of the **HD** Regulator. When the solenoid pilot is used, the regulator can be turned on or off by electrically activating or de-activating the solenoid.

Normally Closed (nc) – Standard

The normally closed Solenoid Pilot remains closed in the non-activated state. The regulating valve will remain closed until an electrical signal is sent to the solenoid pilot. This is known as a fail-safe condition.

Normally Open (no) – Optional

The normally opened Solenoid Pilot remains open in the non-activated state. The regulating valve will function normally unless an electrical signal is used to shut-off the solenoid pilot.

FEATURES

- Available normally opened (no) or normally closed (nc)
- Full-port strainer and blow-down valve on pilot adapter to eliminate failure caused by contaminated steam systems

OPTIONS

- Normally open solenoid
- NEMA Ratings: NEMA 4 and NEMA 7
- Voltage: 24 VAC, 220 VAC, 240 VAC

MINIMUM OPERATING PRESSURES

Minimum Inlet Pressure:

- 15 PSIG** (Standard Main Valve)
- 5 PSIG** (Low Pressure Main Valve)

Minimum Differential Pressure:

- 10 PSI** (Standard Main Valve)
- 3 PSI** (Low Pressure Main Valve)

STANDARD SOLENOID PILOTS AVAILABLE

Steam Inlet Pressure	0-180 PSIG 180-250 PSIG
NEMA Ratings	NEMA 1 – Standard NEMA 4 – Waterproof (optional) NEMA 7 – Explosion-proof (optional)
Voltage	110 Volts AC (standard) 24 Volts AC (optional) 220 Volts AC (optional) 240 Volts AC (optional)

MATERIALS

Pilot Body & Cover	Ductile Iron
Gasket	Grafoil
Cover Screws	Steel, GR5
Internals	Stainless Steel

HOW TO ORDER

"S" SOLENOID PILOT

- Specify:
- Inlet Steam Pressure range:
0-180 PSIG or 180-250 PSIG
 - NEMA rating: NEMA 1, NEMA 4 or NEMA 7
(if not specified NEMA 1 Standard will be supplied)
 - Control Voltage: 24, 110, 220 or 240 VAC

REGULATOR BODY

- Specify:
- **HD** regulator body
 - Regulator size or capacity of steam required
 - End connections (threaded, 150/300# flanged)

"DP" Pilot

Watson McDaniel reserves the right to change the designs and/or materials of its products without notice.
©2010 Watson McDaniel Company

Differential Pressure Pilot for HD Regulating Valves

Differential Pressure Pilot



PILOT-OPERATED REGULATING VALVES

- Max Inlet Pressure: 300 PSIG
- Reduced Outlet Pressure Range: 3-200 PSIG
- Min Inlet Pressures: 15 PSIG standard main valve
5 PSIG low pressure main valve
- DP-Pilot ± 2 PSIG accuracy

PRESSURE-ADJUSTING SPRING RANGES

"DP" Pressure Range	Identifying Colors
3-25 PSIG	yellow
20-100 PSIG	blue
80-200 PSIG	red

TYPICAL APPLICATIONS

The "DP" Differential Pressure Pilot is used with the HD Regulator to maintain steam pressure at a balanced differential pressure above another media source. This is typical on an oil burner where steam used for atomization is injected into the oil burner at a set pressure above the incoming oil supply. Therefore, as oil pressure fluctuates based on demand, the steam pressure will be maintained at a differential pressure above the oil pressure.

FEATURES

- The "DP" Differential Pressure Pilot is used to maintain downstream steam pressure to a set differential pressure above loading pressure
- Accuracy to within ±2 PSIG
- 3 overlapping spring ranges to choose from
- Pilot is installed using only four bolts
- Full port strainer and blowdown valve on pilot adapter for ultimate protection from dirt and scale
- Solid floating diaphragm
- Watson McDaniel's pilots can be used with other manufacturers' regulators

OPTIONS

- Solenoid pilot can be added for remote on/off control of regulator

MINIMUM OPERATING PRESSURES

Minimum Inlet Pressure:

- 15 PSIG (Standard Main Valve)
- 5 PSIG (Low Pressure Main Valve)

Minimum Differential Pressure:

- 10 PSI (Standard Main Valve)
- 3 PSI (Low Pressure Main Valve)

MATERIALS

Pilot Body & Cover	Ductile Iron & Cast Steel
Gasket	Grafoil
Diaphragm	Phosphor Bronze
Head & Seat Assembly	Hardened SST (55 Rc)

HOW TO ORDER

"DP" DIFFERENTIAL PRESSURE PILOT

Specify: • Reduced pressure range –

Example: "DP" Pilot at 3-25 PSIG, yellow

REGULATOR BODY

Specify: • HD regulator body
• Regulator size or capacity
• End connections (threaded, 150/300# flanged)

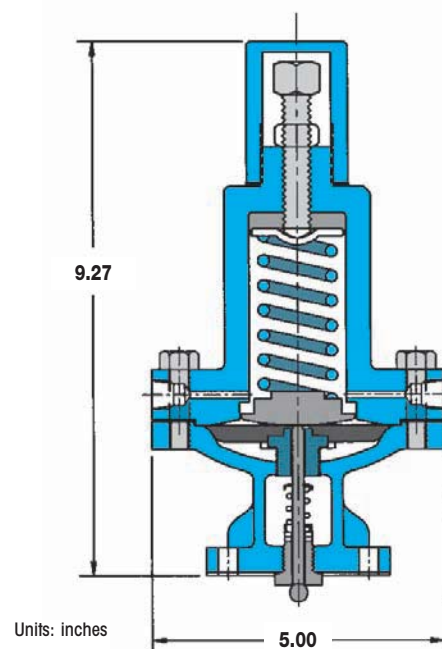

Over Pressure Protection Methods

Using "P" and "BP" Pilots

Back Pressure Regulators for Boiler Overload Protection

In steam systems with several applications of varying importance, a back pressure regulator may be used to prevent overloading of the boiler by isolating non-essential loads from critical processes in the event steam demand exceeds boiler output. When steam demand is greater than the capacity the boiler can generate, pressure in the boiler will drop, possibly upsetting the control balance in the boiler resulting in the generation of wet steam. Using back pressure regulators on the non-essential application supply lines allows isolation of these applications at times of peak demand by shutting off steam flow to areas deemed non-essential. This ensures that boiler demand is not exceeded and steam flow is maintained to critical processes until demand subsides and the boiler is able to catch up.

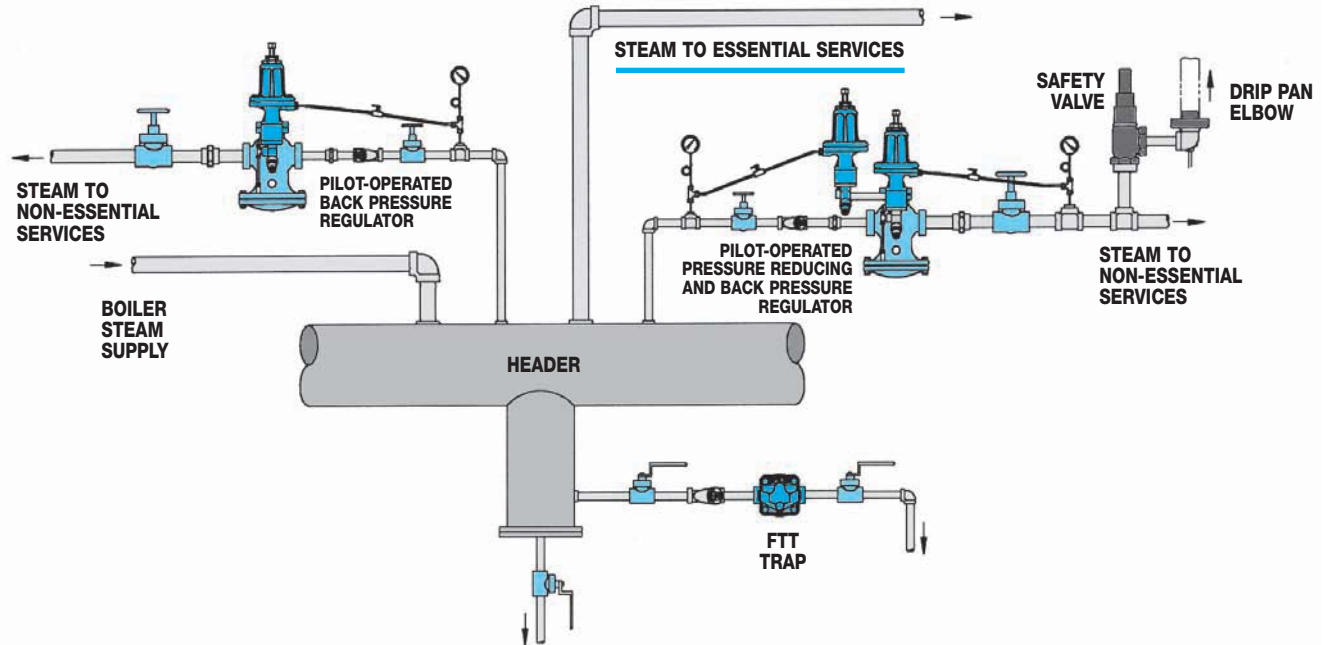

PILOT-OPERATED REGULATING VALVES

Pressure Override Protection of Regulator Supply Lines

On multi-stage pressure reducing applications where a rise in control pressure due to failure of the final supply regulator could result in equipment damage and/or personnel injury, a secondary pressure pilot may be added to provide override protection of a steam supply line. During normal operation, the main pressure pilot on the 1st stage regulator provides intermediate pressure control while the additional "monitor" pilot senses final control pressure and remains open due to a slightly higher setting than the final control pressure setting. Should the 2nd stage regulator fail for any reason, increasing supply pressure will begin to close the monitor pressure pilot of the 1st stage regulator, thus overriding the main control pilot preventing final supply pressure from increasing. This overpressure protection can similarly be offered on single-stage reducing valves by protecting against failure of the main control pilot.

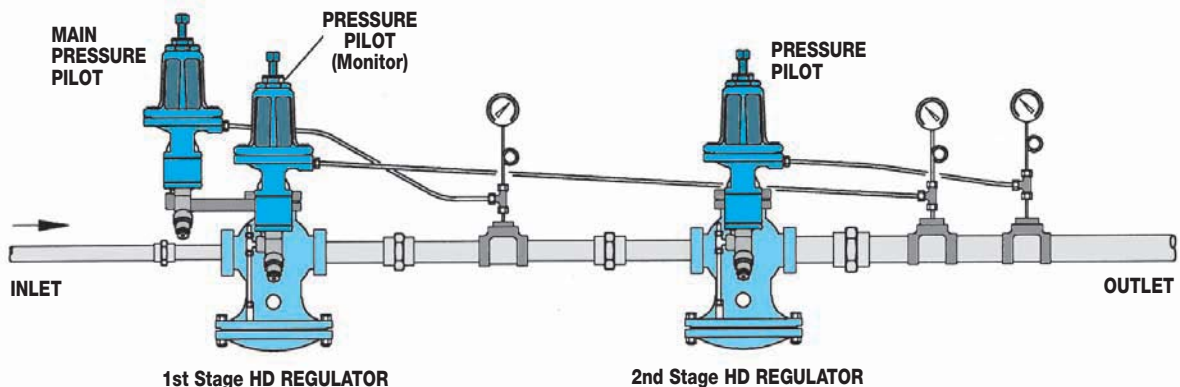

HDP

Pilot-Operated Pressure Regulating Valve

Watson McDaniel reserves the right to change the designs and/or materials of its products without notice.
©2010 Watson McDaniel Company

PILOT-OPERATED
REGULATING VALVES

HD Regulating Valve with "P" Pressure Pilot

- Max Inlet Pressure: 300 PSIG
- Reduced Outlet Pressure Range: 3-200 PSIG
- Min Inlet Pressures:
 - 15 PSIG standard main valve
 - 5 PSIG low pressure main valve



TYPICAL APPLICATIONS

The HD Regulator with the "P" Pressure Pilot is used for reducing steam pressure in piping mains and process applications. Pilot-operated regulators will maintain constant downstream pressure even when the inlet pressure to the regulator fluctuates or steam usage varies.

FEATURES

- The "P" Pilot can maintain downstream pressure to ± 1 PSIG
- Optional "P5" pilot can maintain pressure to ± 0.5 PSIG
- Choices of three overlapping pressure ranges
- Pressure adjusting spring can be changed with regulator in line
- Pilot is easily installed using only four bolts
- Full port strainer and blowdown valve on pilot adapter for ultimate protection from dirt and scale
- Watson McDaniel's pilots can be used with other manufacturers' regulators

OPTIONS

- Pressure and temperature pilots can be combined on the same regulator
- Solenoid pilot can be added for electrical on/off control of the regulator
- Can be used with solenoid and temperature pilots

MINIMUM OPERATING PRESSURES

Minimum Inlet Pressure:

15 PSIG (Standard Main Valve)

5 PSIG (Low Pressure Main Valve)

Minimum Differential Pressure:

10 PSI (Standard Main Valve)

3 PSI (Low Pressure Main Valve)

PRESSURE-ADJUSTING SPRING RANGES "P"

Pressure Ranges	Identifying Colors
3-25 PSIG	yellow
20-100 PSIG	blue
80-200 PSIG	red

PRESSURE-ADJUSTING SPRING RANGES "P5"

1-10 PSIG	yellow
10-25 PSIG	blue

MATERIALS

Body	Ductile Iron
Cover	Ductile Iron
Gasket	Grafoil
Cover Screws	Steel
Pilot Adapter	Ductile Iron/Cast Steel
Screen	Stainless Steel
Tubing	Copper
Valve Seat	Hardened SST (55 Rc)
Valve Disc	Hardened SST (55 Rc)
Diaphragm	Phosphor Bronze

Pilot-Operated Pressure Regulating Valve

DIMENSIONS HD-Series – inches / pounds

Size	Face-To-Face			B	C*	D	E**	Weight (lbs)	
	NPT	150#	300#					NPT	FLG
1/2"	43/8			5 1/2	11 7/8	6 1/2	7 3/4	18	
3/4"	4 3/8			5 1/2	11 7/8	6 1/2	7 3/4	18	
1"	5 3/8	5 1/2	6	6 1/4	11 7/8	7	7 3/4	23	35
1 1/4"	6 1/2			7 3/8	11 7/8	8 3/4	8 1/4	43	
1 1/2"	7 1/4	6 7/8	7 3/8	7 3/8	11 7/8	8 3/4	8 1/4	43	60
2"	7 1/2	8 1/2	9	8 1/4	11 7/8	10 7/8	8 1/2	65	85
2 1/2"		9 3/8	10	9	11 7/8	11 3/4	8 1/2		105
3"		10	10 3/4	8 7/8	11 7/8	13 1/4	9 1/2		145
4"		11 7/8	12 1/2	10 7/8	11 7/8	14 3/4	10 1/2		235
6"		15 1/8	16	14 1/8	12 1/2	19 3/4	11 3/4		470

For P5 Pilot:

* For sizes 1/2" to 1 1/2" add 2 1/2" to "C" dimension;

For sizes 2" to 6" add 5" to "C" dimension.

** Add 1 1/2" to "E" dimension for all sizes.

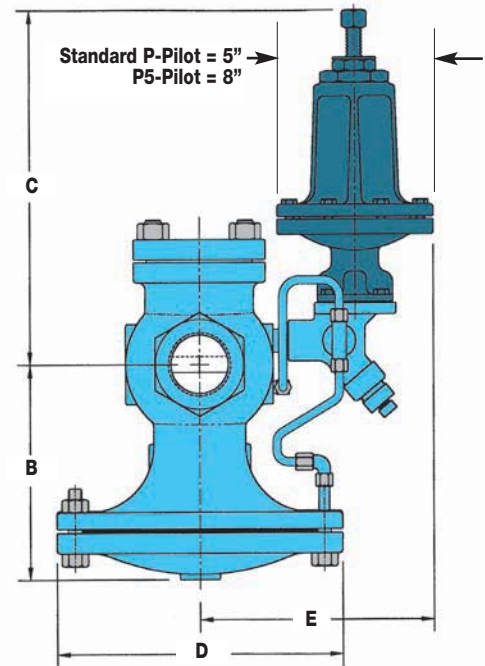

PILOT-OPERATED REGULATING VALVES

HOW TO ORDER

P or P5 PRESSURE PILOT

Specify: • Reduced pressure range
(P5 Pilot requires a special adapter block on 3" & 4" valves)

REGULATOR BODY

Specify: • HD regulator body
• Regulator size or capacity and pressures of steam required
• End connections (threaded, 150/300# flanged)

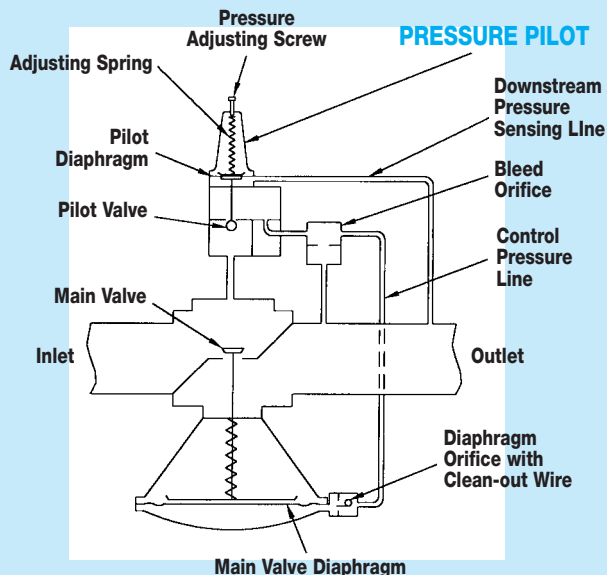

HOW IT WORKS

The purpose of the pressure pilot is to control the operation of the pressure regulating valve. A pressure sensing line connects the pressure pilot to the downstream side of the regulator. The pressure in the sensing line is directed under the diaphragm in the pressure pilot. When the pressure in the system reaches the adjusting spring set point it pushes the diaphragm upwards against the force of the adjusting spring and closes the pilot valve. When the pilot valve is shut, steam can no longer pass through to the underside of the regulator diaphragm and the main valve closes. When the steam pressure falls below its set point, the pilot valve opens allowing steam to lift the main valve diaphragm which opens up the regulating valve.

HDT

Pilot-Operated Temperature Regulating Valve

Watson McDaniel reserves the right to change the designs and/or materials of its products without notice.
©2010 Watson McDaniel Company

HD Regulating Valve with "T" Temperature Pilot

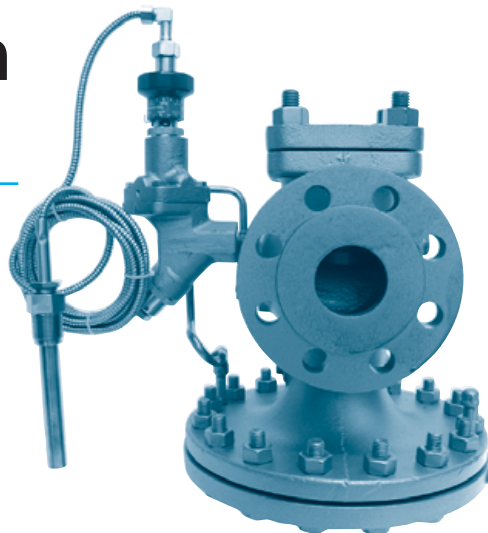

PILOT-OPERATED REGULATING VALVES

- Inlet Pressure Max: 300 PSIG
- Temperature Control Range: 60–260 °F
- Min Inlet Pressures:
 - 15 PSIG standard main valve with standard temperature pilot
 - 5 PSIG low pressure main valve with low pressure temp. pilot

Low Pressure Temperature Pilot must be used in conjunction with a low pressure main valve for applications where inlet steam pressure is less than 15 PSIG. SPECIFY WHEN ORDERING.

TYPICAL APPLICATIONS

The HD Regulator with the "T" Temperature Pilot is used for controlling temperature in various processes and systems, such as Oil Heaters, Ovens, Process Heaters, Vats, Dryers and Jacketed Kettles.

FEATURES

- Temperature adjustment made simple and easy by rotating an adjustment knob to the desired temperature setting
- Thermostatic sensing bulb comes with 8-ft. or 15-ft. capillary; optional lengths up to 25-ft. max
- Capillary is armor-protected to resist damage
- Optional stainless steel sensing bulb and capillary
- Overheat protection bellows is incorporated into sensing bulb; 200°F overheat protection up to 350°F
- Can be used with Pressure Pilot for simultaneous control of pressure and temperature
- Hardened stainless steel trim on regulator for extended service life
- Full port strainer and blowdown valve on pilot adapter for ultimate protection from dirt and scale

OPTIONS

- Temperature Pilot can be combined with Pressure and Solenoid pilots
- Additional capillary lengths can be ordered in 5-ft. increments; up to 25-ft. maximum length
- Wells* are available in 316 stainless steel
- Longer wells can be supplied
- Low pressure (under 15 PSIG) temperature pilot
- Consult factory for other options

TEMPERATURE-ADJUSTING RANGES

Temperature Ranges *	Identifying Colors
60 - 120 °F (16 - 49 °C)	yellow
100 - 160 °F (38 - 71 °C)	black
120 - 180 °F (49 - 82 °C)	blue
160 - 220 °F (71 - 104 °C)	red
200 - 260 °F (93 - 127 °C)	green

* Other ranges available; consult Factory.

MATERIALS

Body	Ductile Iron
Cover	Ductile Iron
Gasket	Grafoil
Cover Screws	Steel
Pilot Adapter	Ductile Iron/Cast Steel
Screen	Stainless Steel
Tubing	Copper
Valve Seat	Hardened SST (55 Rc)
Valve Disc	Hardened SST (55 Rc)
Diaphragm	Phosphor Bronze

* Thermowells:

Wells isolate sensing bulb from the process liquid and are available in Brass or Stainless Steel. When placed on the side of a tank or vessel, the sensing bulb can be removed without having to drain the process fluid.

Pilot-Operated Temperature Regulating Valve

DIMENSIONS HD-Series – inches / pounds

Size	Face-To-Face			B	C	D	E	Weight (lbs)	
	NPT	150#	300#					NPT	FLG
1/2"	43/8			5 1/2	9 1/4	6 1/2	6 1/2	18	
3/4"	43/8			5 1/2	9 1/4	6 1/2	6 1/2	18	
1"	53/8	5 1/2	6	6 1/4	9 1/4	7	8 1/4	23	35
1 1/4"	6 1/2			7 3/8	9 1/4	8 3/4	7 1/4	43	
1 1/2"	7 1/4	6 7/8	7 3/8	7 3/8	9 1/4	8 3/4	7 1/4	43	60
2"	7 1/2	8 1/2	9	8 1/4	9 1/4	10 7/8	7 1/2	65	85
2 1/2"		9 3/8	10	9	9 1/4	11 3/4	7 3/4		105
3"		10	10 3/4	8 7/8	9 1/4	13 1/4	8 1/2		145
4"		11 7/8	12 1/2	10 7/8	9 1/4	14 3/4	9 1/2		235
6"		15 1/8	16	14 1/8	9 3/4	19 3/4	10 3/4		470

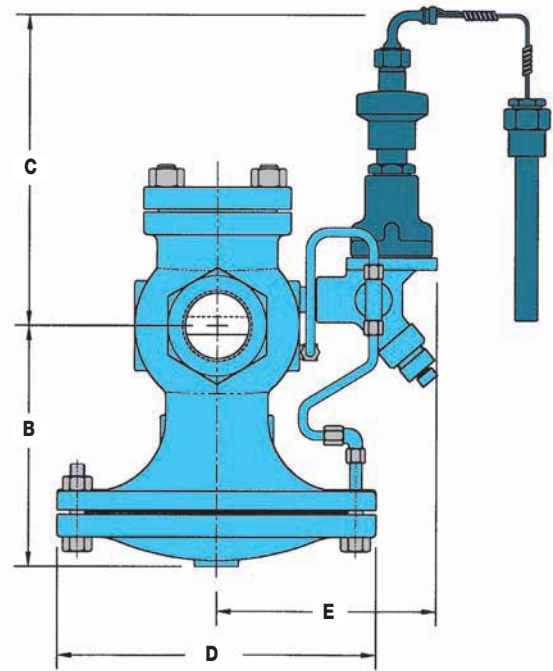

PILOT-OPERATED REGULATING VALVES

HOW TO ORDER

"T" TEMPERATURE PILOT

Specify:

- Temperature range from the chart or indicate the set temperature of the process you wish to control
- The length of capillary required. 8-ft. or 15-ft. standard; Maximum length: 25-ft. in 5-ft. increments
- Bulb type needed: T, TU, TUBW, TUSW, TBW & TSW

REGULATOR BODY

Specify:

- HD regulator body
- Regulator size or capacity
- End connections (threaded, 150/300# flanged)

MINIMUM OPERATING PRESSURES

Minimum Inlet Pressure:

- 15 PSIG** (Standard Main Valve with Standard Temperature Pilot)
- 5 PSIG** (Low Pressure Main Valve with Low Pressure Temperature Pilot)

Low Pressure Temperature Pilot must be used in conjunction with a Low Pressure Main Valve for applications where inlet steam pressure is less than 15 PSIG. SPECIFY WHEN ORDERING.

HOW IT WORKS

The temperature pilot controls the operation of the temperature regulating valve. The temperature sensing bulb, which is filled with a temperature sensitive liquid, is placed in the process fluid that is being heated. When the temperature of the process fluid reaches its set point, the bellows expands and closes off the pilot valve. When the pilot valve is shut, steam can no longer pass thru to the underside of the regulator diaphragm, and the main valve closes. When the process fluid cools below the set temperature, the main valve reopens.

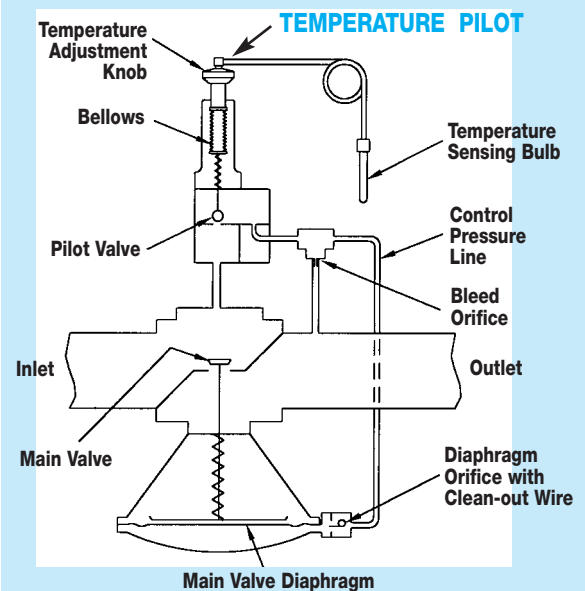

HDA

Air-Operated Pilot Regulating Valve

Watson McDaniel reserves the right to change the designs and/or materials of its products without notice.
©2010 Watson McDaniel Company

HD Regulating Valve with "A" Air Pilot

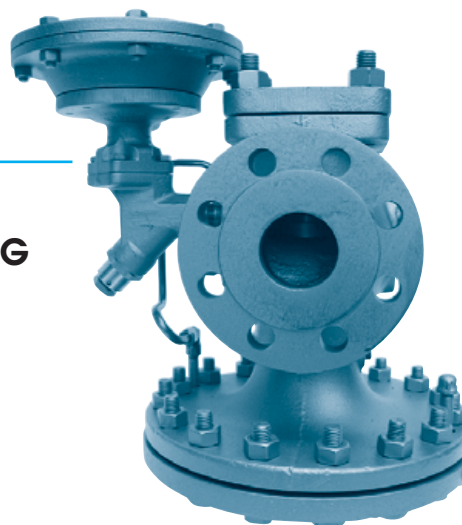

PILOT-OPERATED REGULATING VALVES

- **Max Inlet Pressure: 300 PSIG**
- **Reduced Outlet Pressure Range: 3-200 PSIG**
- **Min Inlet Pressures:**
 - 15 PSIG** standard main valve
 - 5 PSIG** low pressure main valve

Note: Temperature Range: 0-350°F when used with PTL & PTR temperature controllers

TYPICAL APPLICATIONS

The HD Regulator with the "A" Air Pilot is used for reducing steam pressure on steam mains and process equipment. The "A" Air Pilot can also be used in conjunction with the PTL and PTR Pneumatic Temperature Controllers for controlling temperature in process applications. The principal advantage of the "A" Air Pilot over standard spring-loaded pilots is that pressure adjustments to the regulator can be made from a remote location. A regulator placed in a difficult to reach or inaccessible location can be adjusted by a remote control panel board placed in an accessible location.

FEATURES

- Air Pilot can be used with PTL or PTR Pneumatic Temperature Controller
- Pressure adjustments of the regulator can be done from a remote location
- Air-operated pilot insures instant response and very accurate control
- Full port strainer and blowdown valve on pilot adapter for ultimate protection from dirt and scale
- Controls pressure settings within ± 1 PSIG

OPTIONS

- Solenoid Pilot (S-Pilot) can be added for Electrical On/Off Operation of the regulator

MAXIMUM CONTROL AIR PRESSURE ON AIR PILOT IS 125 PSIG

PRESSURE-ADJUSTING RANGES		
Model	Pressure Ranges	Description
A1	3-125 PSIG	1:1 ratio of steam pressure to control air pressure Example: With the A1 air pilot, 10 PSIG of air pressure maintains 10 PSIG of steam pressure
A4	3-200 PSIG	4:1 ratio of steam pressure to control air pressure Example: With the A4 air pilot, 10 PSIG of air pressure maintains 40 PSIG of steam pressure
A6	20-200 PSIG	6:1 ratio of steam pressure to control air pressure Example: With the A6 air pilot, 10 PSIG of air pressure maintains 60 PSIG of steam pressure

MINIMUM OPERATING PRESSURES

Minimum Inlet Pressure:

15 PSIG (Standard Main Valve)

5 PSIG (Low Pressure Main Valve)

Minimum Differential Pressure:

10 PSI (Standard Main Valve)

3 PSI (Low Pressure Main Valve)

CONTROL AIR PRESSURE RANGE

A-Pilot Control Pressure:

3-125 PSIG (depending on pilot selected and desired outlet pressure)

Air-Operated Pilot Regulating Valve

DIMENSIONS HD-Series – inches / pounds

Size	Face-To-Face			B	C*	D	E**	Weight (lbs)	
	NPT	150#	300#					NPT	FLG
1/2"	43/8			5 1/2	7 1/2	6 1/2	7 3/4	18	
3/4"	43/8			5 1/2	7 1/2	6 1/2	7 3/4	18	
1"	53/8	5 1/2	6	6 1/4	7 1/2	7	7 3/4	23	35
1 1/4"	6 1/2			7 3/8	7 1/2	8 3/4	8 3/8	43	
1 1/2"	7 1/4	6 7/8	7 3/8	7 3/8	7 1/2	8 3/4	8 3/8	43	60
2"	7 1/2	8 1/2	9	8 1/4	7 1/2	10 7/8	8 3/4	65	85
2 1/2"		9 3/8	10	9	7 1/2	11 3/4	8 3/4		105
3"		10	10 3/4	8 7/8	7 1/2	13 1/4	9 1/2		145
4"		11 7/8	12 1/2	10 7/8	7 1/2	14 3/4	10 1/2		235
6"		15 1/8	16	14 1/8	8 1/4	19 3/4	11 3/4		470

* Add 2 1/2" to "C" dimension for A4 or A6 Air Pilots on 2" thru 4" valves.

** Add 1 1/2" to "E" dimension for A4, and 2 1/4" for A6.

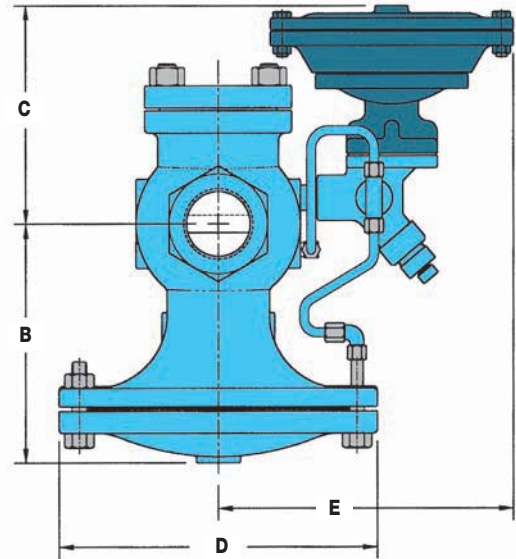

PILOT-OPERATED REGULATING VALVES

MATERIALS

Body	Ductile Iron
Cover	Ductile Iron
Gasket	Grafoil
Cover Screws	Steel
Pilot Adapter	Ductile Iron/Cast Steel
Screen	Stainless Steel
Tubing	Copper
Valve Seat	Hardened SST (55 Rc)
Valve Disc	Hardened SST (55 Rc)
Diaphragm	Phosphor Bronze

HOW IT WORKS

When air pressure is applied to the upper chamber of the air pilot it exerts a downward force on the air pilot's diaphragm. The lower chamber of the air pilot is connected to the outlet side of the regulator using a sensing line. The purpose of the sensing line is to sense the pressure on the outlet side of the regulator. When the intended set pressure is reached, the pilot valve closes which then closes off the flow path of steam to the underside of the diaphragm chamber in the regulator body. The regulator modulates maintaining the desired downstream pressure regardless of the amount of steam being used.

HOW TO ORDER

"A" AIR PILOT

- Specify:
- Air Pilot **A1**, **A4** or **A6**
 - Remote Control Panel Board: **PL1**, **PL2** or **PL3**

REGULATOR BODY

- Specify:
- **HD** regulator body
 - Regulator size or capacity and pressures of steam required
 - End connections (threaded, 150/300# flanged)

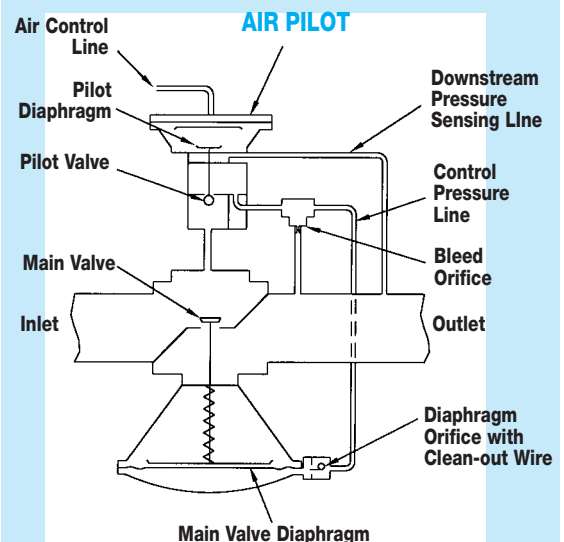

HDPT

Pilot-Operated Pressure & Temperature Regulating Valve

HD Regulating Valve with "P" Pressure & "T" Temperature Pilots

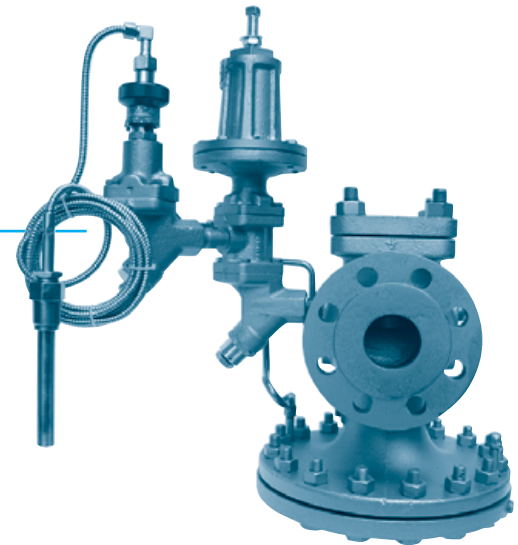

PILOT-OPERATED REGULATING VALVES

- Max Inlet Pressure: 300 PSIG
- Reduced Outlet Pressure Range: 3-200 PSIG
- Temperature Control Range: 60-260 °F
- Min Inlet Pressures:
 - 15 PSIG standard main valve with standard temperature pilot
 - 5 PSIG low pressure main valve with low pressure temp. pilot

Low Pressure Temperature Pilot must be used in conjunction with a low pressure main valve for applications where inlet steam pressure is less than 15 PSIG.
SPECIFY WHEN ORDERING

TYPICAL APPLICATIONS

The HD Regulator with both the "P" Pressure Pilot and "T" Temperature Pilot is used to simultaneously control both pressure and temperature in process applications.

Using both the temperature and pressure pilot on the same regulator eliminates the need for two separate regulators to control temperature and pressure.

FEATURES

- Pressure and temperature pilot combination eliminates the need for two separate regulators
- Choice of three overlapping pressure ranges
- Pilot is installed using only four bolts
- Full port strainer and blowdown valve on pilot adapter for ultimate protection from dirt and scale
- Watson McDaniel's pilots can be used with other manufacturers' valves

OPTIONS

- Solenoid Pilot can be added for electrical On/Off control of the regulator

TEMPERATURE-ADJUSTING RANGES

Temperature Ranges *	Identifying Colors
60 - 120 °F (16 - 49 °C)	yellow
100 - 160 °F (38 - 71 °C)	black
120 - 180 °F (49 - 82 °C)	blue
160 - 220 °F (71 - 104 °C)	red
200 - 260 °F (93 - 127 °C)	green

* Other ranges available; consult Factory.

PRESSURE-ADJUSTING SPRING RANGES

Pressure Ranges	Identifying Colors
3-25 PSIG	yellow
20-100 PSIG	blue
80-200 PSIG	red

MINIMUM OPERATING PRESSURES

Minimum Inlet Pressure:

- 15 PSIG (Standard Main Valve with Standard Temperature Pilot)
- 5 PSIG (Low Pressure Main Valve with Low Pressure Temperature Pilot)

Minimum Differential Pressure:

- 10 PSI (Standard Main Valve)
- 3 PSI (Low Pressure Main Valve)

Pilot-Operated Pressure & Temperature Regulating Valve

DIMENSIONS HD-Series – inches/pounds

Size	Face-To-Face			B	C	D	E	Weight (lbs)	
	NPT	150#	300#					NPT	FLG
1/2"	43/8			5 1/2	14 1/2	6 1/2	10 1/4	18	
3/4"	43/8			5 1/2	14 1/2	6 1/2	10 1/4	18	
1"	53/8	5 1/2	6	6 1/4	14 1/2	7	10 1/4	23	35
1 1/4"	6 1/2			7 3/8	14 1/2	8 3/4	10 3/4	43	
1 1/2"	7 1/4	6 7/8	7 3/8	7 3/8	14 1/2	8 3/4	10 3/4	43	60
2"	7 1/2	8 1/2	9	8 1/4	14 1/2	10 7/8	11 1/4	65	85
2 1/2"		9 3/8	10	9	14 1/2	11 3/4	11 1/4		105
3"		10	10 3/4	8 7/8	14 1/2	13 1/4	12		145
4"		11 7/8	12 1/2	10 7/8	14 1/2	14 3/4	13		235
6"		15 1/8	16	14 1/8	15	19 3/4	14 1/4		470

MATERIALS

Body	Ductile Iron
Cover	Ductile Iron
Gasket	Grafoil
Cover Screws	Steel
Pilot Adapter	Ductile Iron/Cast Steel
Screen	Stainless Steel
Tubing	Copper
Valve Seat	Hardened SST (55 Rc)
Valve Disc	Hardened SST (55 Rc)
Diaphragm	Phosphor Bronze

HOW TO ORDER

"T" TEMPERATURE PILOT

- Specify:
- Temperature range from the chart or indicate the set temperature of the process you wish to control
 - The length of capillary required; 8-ft. is standard
 - Bulb type needed: T, TU, TUBW, TUSW, TBW & TSW

"P" PRESSURE PILOT

- Specify:
- Pressure range from the chart

REGULATOR BODY

- Specify:
- HD regulator body
 - Regulator size or capacity and pressures of steam required
 - End connections (threaded, 150/300# flanged)

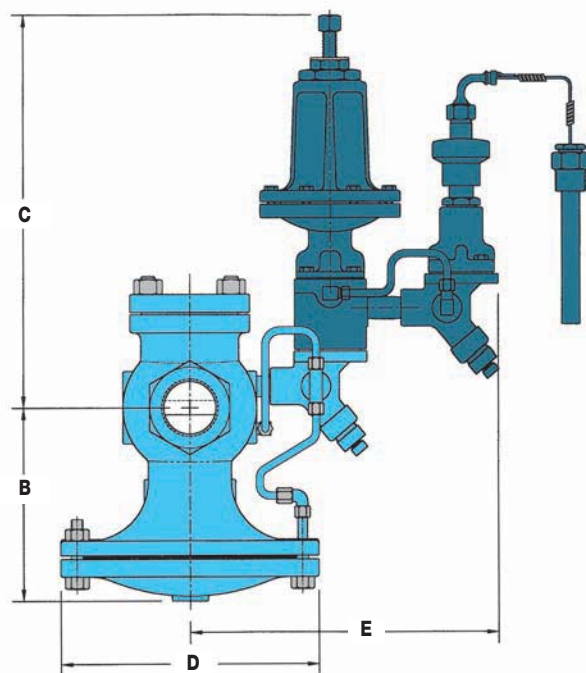

HOW IT WORKS

A pressure pilot and temperature pilot can be used together to control the operation of the regulator. The pressure pilot limits the outlet pressure of the regulator when the temperature pilot calls for steam. The temperature pilot senses the temperature of the process that is being controlled and opens or closes the regulator accordingly. Using a pressure-temperature pilot combination eliminates having to use two separate valves.

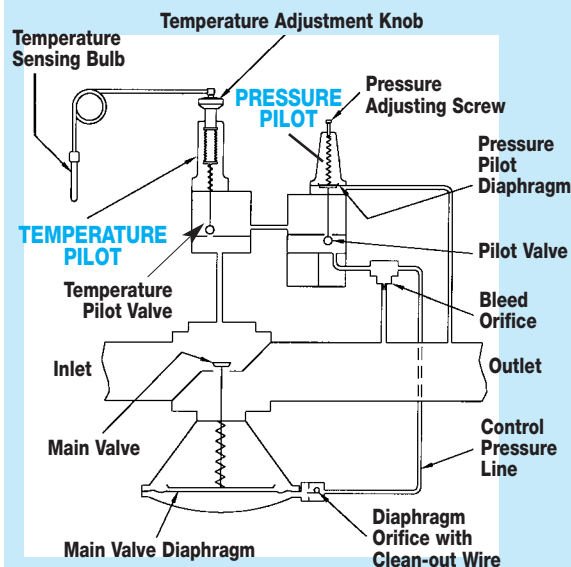

REGULATORS

HSP Series CAST STEEL

Pilot-Operated Pressure Regulating Valve

Watson McDaniel reserves the right to change the designs and/or materials of its products without notice.
©2010 Watson McDaniel Company

PILOT-OPERATED
REGULATING VALVES

Model	HSP Series
Sizes	1", 1 1/2", 2", 3", 4"
Connections	150#/300# Flange
Body Material	Cast Steel
PMO Max. Operating Pressure	450 PSIG
TMO Max. Operating Temperature	650°F
PMA Max. Allowable Pressure	550 PSIG @ 650°F
TMA Max. Allowable Temperature	650°F @ 550 PSIG

PRESSURE-ADJUSTING SPRING RANGES	
Pressure Ranges	Identifying Colors
10-40 PSIG	yellow
25-100 PSIG	blue
75-300 PSIG	red



TYPICAL APPLICATIONS

The **HSP-Series** Main Valve with integral Pressure Pilot reduces steam pressure in steam system piping mains and process applications. This pilot-operated regulator is specifically used in applications where the properties and benefits of Cast Steel are desired and/or specified. Using steel as the material of construction for the main valve body extends the temperature ranges of the regulator. A unique two-bolt pilot adapter design and field-reversible tubing offer even greater versatility to this type of regulator, further reducing maintenance downtime. These valves share the same design and proven reliability of the Watson McDaniel HD-Series Regulators, providing extremely accurate control of downstream system pressure even when inlet pressure to the regulator fluctuates or steam usage varies.

FEATURES

- **Cast Steel body for higher pressure and temperature ratings**
- **New, convenient bolt-on pilot design simplifies installation**
- **New diaphragm design improves performance and extends life**
- **Hardened stainless steel trim for extended life**
- **Optional Stellite trim available**
- **Full port strainer and blowdown valve on pilot adapter for ultimate protection from dirt and scale**
- **Maintains downstream pressure + 1.0 PSIG**
- **Choice of three overlapping spring ranges**
- **Pre-mounted pilot & tubing simplifies installation**

CONTROL PILOTS

Pilot Mounting

Standard pilot mounting is on the right side of the regulator when looking into the outlet port (see diagram on opposite page which is right mounted). For opposite mounting, please specify when ordering. Pilot mounting on HSP regulators are field reversible.

Pressure

The spring-adjusted Pilot is used for general purpose pressure reducing applications.

MATERIALS

Body	ASTM A-216 GR WCB
Cover	ASTM A-216 GR WCB
Diaphragm Cover	ASTM A-216 GR WCB
Pilot	ASTM A-216 GR WCB
Gaskets	Garlock 3400/grafoil SLS
Seat	420F SS (optional Stellite seat, consult factory)
Disc	420F SS
Diaphragm	300 SS
Mfg. Bolts	SA-193 GR B7
Spring	302 SS
Stem	416 SS

HSP Series CAST STEEL

Pilot-Operated Pressure Regulating Valve

DIMENSIONS HSP Series – inches / pounds															
Size	(A) Face-To-Face			B			C			D			Weight (lbs)		
	NPT	150#	300#							NPT	150#	300#			
1"	x	5 1/2	6	6 1/4	3 1/2	7	x	40	45						
1 1/2"	x	6 7/8	7 3/8	7 3/8	4 7/8	8 3/4	x	55	60						
2"	x	8 1/2	9	8 1/4	5 3/8	10 7/8	x	75	85						
3"	x	10	10 3/4	8 7/8	6 3/4	13 1/4	x	130	145						
4"	x	11 7/8	12 1/2	10 7/8	7 1/2	14 3/4	x	215	235						

MINIMUM OPERATING PRESSURES

Minimum Inlet Pressure:

- 15 PSIG (standard Main Valve)
- 5 PSIG (low pressure Main Valve)

Minimum Differential Pressure:

- 10 PSIG (standard Main Valve)
- 3 PSIG (low pressure Main Valve)

HOW TO ORDER

REGULATOR BODY

- Specify:
- HSP regulator body
 - Regulator size or capacity of steam required
 - End connections (150#/300# flanged)

PILOT REQUIRED TO OPERATE THIS VALVE

- Pressure Pilot (Specify Range)

- Specify:
- 10-40 PSIG - Yellow
 - 25-100 PSIG - Blue
 - 75-300 PSIG - Red

Example: 2" HSP, 150# FLG, 10-40 PSIG (yellow)

PILOT-OPERATED
REGULATING VALVES

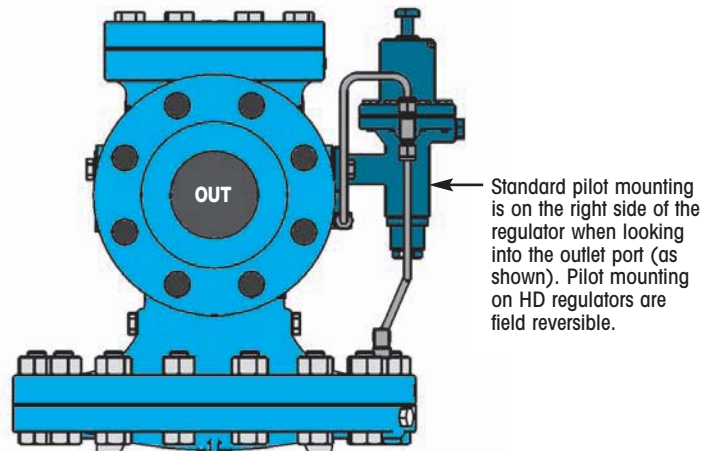
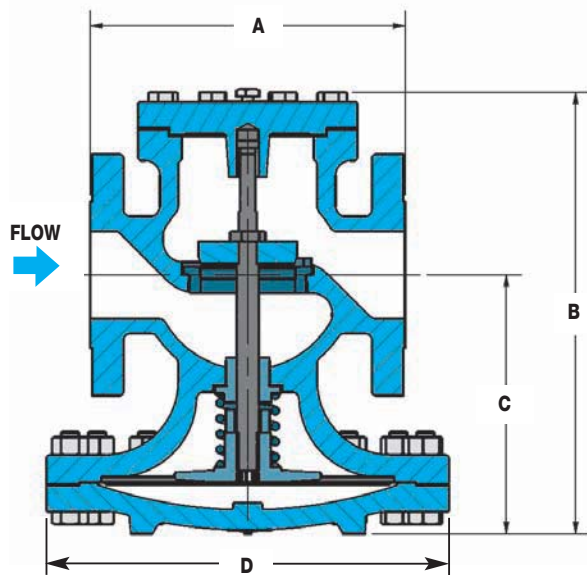

NOISE ATTENUATORS

Series-A ORIFICE PLATE for Pressure Regulating Valves

Watson McDaniel reserves the right to change the designs and/or materials of its products without notice.
©2010 Watson McDaniel Company

Noise Attenuation Equipment is used to reduce unwanted or excessive noise that commonly occurs in pressure reducing stations.

Series-A ORIFICE PLATE

Noise Reduction Capability: 5-10 dBA

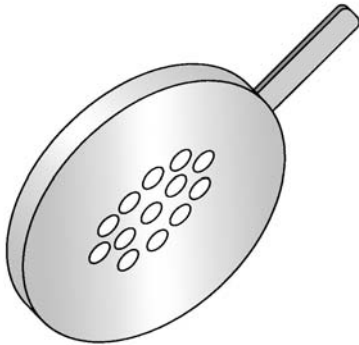

Series-A Orifice Plate

HOW IT WORKS

The **Series-A** Orifice Plate with its drilled orifice pattern is installed after the pressure regulating valve to smooth out turbulence caused by the pressure drop across the regulator. Noise reduction levels of **5-10 dBA** can typically be achieved.

INSTALLATION

The Series-A Orifice Plate is installed between ANSI flanges immediately after the regulator. If the regulator is a flanged unit, the orifice plate is placed at the flange outlet connection.

PILOT-OPERATED
REGULATING VALVES

Series-A Typical Hook-up

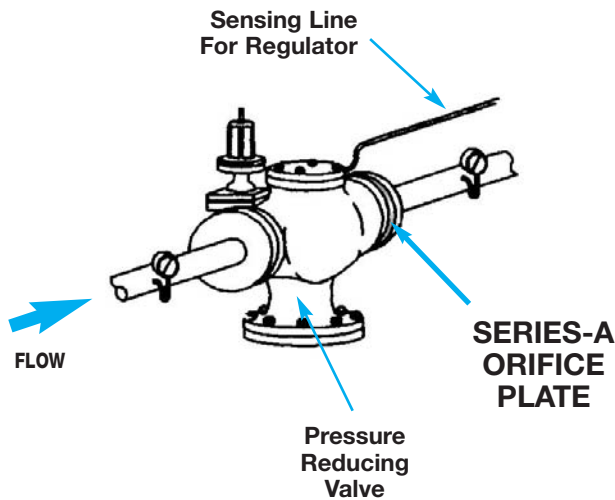

Series A Dimensions

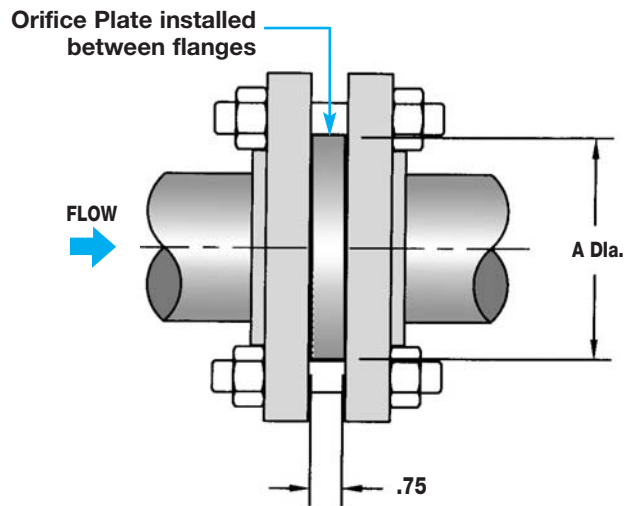

Series-A DIMENSION (A) – inches

Pipe Size	125# Flange	250# Flange
2"	6	4 ³ / ₁₆
2½"	7	4 ¹⁵ / ₁₆
3"	7½	5 ¹¹ / ₁₆
4"	9	6 ¹⁵ / ₁₆
6"	11	9 ¹¹ / ₁₆

Note: Other sizes available. Consult factory.

NOISE ATTENUATORS

ACOUSTIC SILENCER **Series-H** for Pressure Regulating Valves

Noise Attenuation Equipment is used to reduce unwanted or excessive noise that commonly occurs in pressure reducing stations.

Series-H ACOUSTIC SILENCER

Noise Reduction Capability: 20-30 dBA

PILOT-OPERATED
REGULATING VALVES

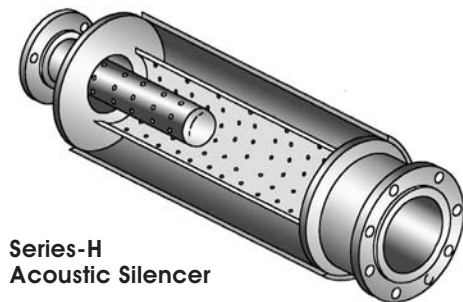

Series-H
Acoustic Silencer

Series-H Dimensions

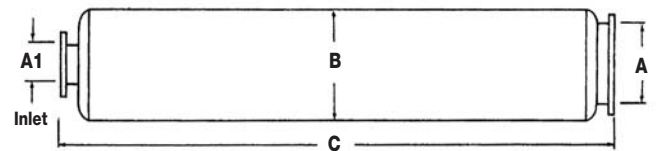

HOW IT WORKS

The **Series-H** Acoustic Silencer incorporates a **Dual Diffuser** tube design. The inner tube has a drilled orifice pattern and the outer tube contains an integral layer of sound absorbing insulation. Noise reduction levels of **20-30 dBA** can typically be achieved.

INSTALLATION

The **Series-H** Diffuser Tube should be installed immediately downstream of the regulator, as shown below.

Series-H DIMENSIONS – inches

Model	A1	A	B	C	Weight (lbs)
LCV-8	4	8	14	57	145
LCV-10	6	10	16	71	210
LCV-12	6	12	18	81	295

Note: Other sizes available. Consult factory.

Series-H Typical Hook-up

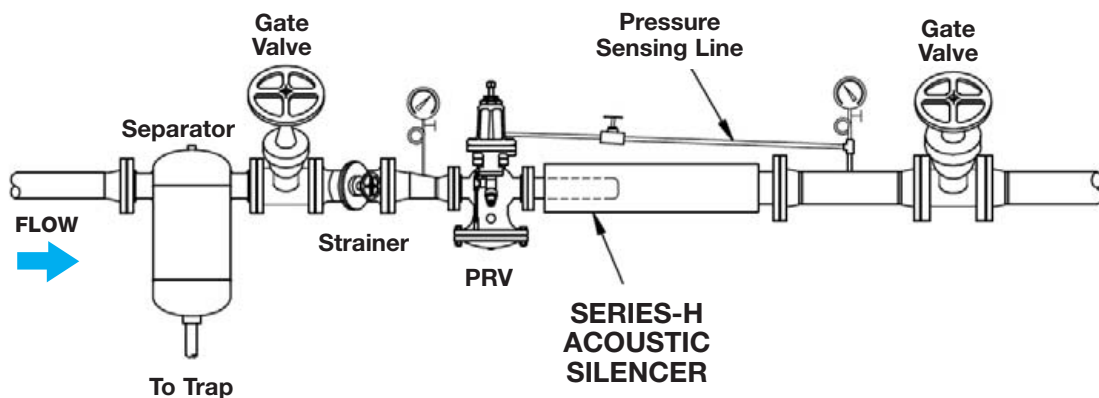

NOISE ATTENUATORS

Series-S ACOUSTIC DIFFUSER for Pressure Regulating Valves

Watson McDaniel reserves the right to change the designs and/or materials of its products without notice.
©2010 Watson McDaniel Company

Series-S ACOUSTIC DIFFUSER

Noise Reduction Capability: 10-15 dBA

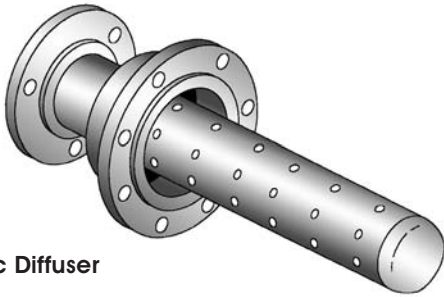

Series-S Acoustic Diffuser

HOW IT WORKS

The **Series-S** Acoustic Diffuser incorporates a single tube with a drilled orifice pattern which reduces downstream turbulence. Noise reduction levels of **10-15 dBA** can typically be achieved.

INSTALLATION

The **Series-S** Diffuser Tube should be installed immediately downstream of the regulator, as shown below.

Series-S Typical Hook-up

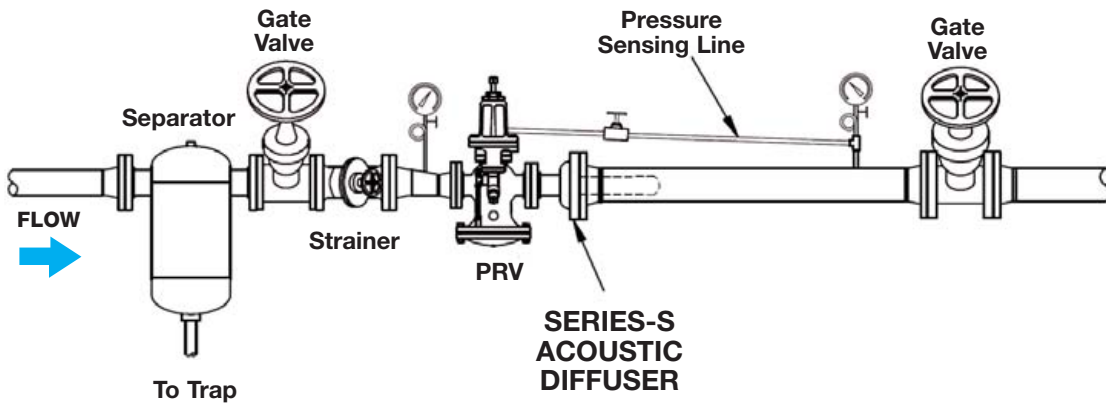

Model Selection Chart for Series-S Diffuser

Steam Capacity (lbs/hr)	Valve Inlet Pressure (PSIG)															
	15	20	25	30	40	50	60	75	90	100	125	150	175	200	225	250
1000	S-3	S-3	S-3	S-3	S-3	S-3	S-3	S-3	S-3	S-3	S-3	S-3	S-3	S-3	S-3	S-3
1500	S-3	S-3	S-3	S-3	S-3	S-3	S-3	S-3	S-3	S-3	S-3	S-3	S-3	S-3	S-3	S-3
2000	S-4	S-4	S-4	S-4	S-4	S-4	S-4	S-4	S-4	S-4	S-4	S-4	S-4	S-4	S-4	S-4
3000	S-4	S-4	S-4	S-4	S-4	S-5	S-5	S-5	S-5	S-5	S-5	S-5	S-5	S-5	S-5	S-5
4000	S-5	S-5	S-5	S-5	S-5	S-5	S-5	S-5	S-5	S-5	S-5	S-5	S-5	S-5	S-5	S-5
6000	S-6	S-6	S-6	S-6	S-6	S-6	S-6	S-6	S-6	S-6	S-6	S-6	S-6	S-6	S-6	S-6
8000	S-8	S-8	S-8	S-8	S-8	S-8	S-8	S-8	S-8	S-8	S-8	S-8	S-8	S-8	S-8	S-8
10000	S-8	S-8	S-8	S-8	S-8	S-8	S-8	S-8	S-8	S-8	S-8	S-8	S-8	S-8	S-8	S-8

Note: For higher capacity models, S-10 & S-12, consult factory.

ACOUSTIC DIFFUSER **Series-S** for Pressure Regulating Valves

Series-S Dimensions – inches

Model	Inlet (A)		Outlet	NPT x Weld Dimensions		
	NPT	FLG		B	C	D
S-3	3/4		2	5 1/2	13 1/2	2 3/8
	1		2	5 1/2	13 1/2	2 3/8
S-4	3/4		4	6 1/2	13 1/2	4 1/2
	1		4	6 1/2	13 1/2	4 1/2
	1 1/4		4	6 1/2	13 1/2	4 1/2
	1 1/2		4	6 1/2	13 1/2	4 1/2
S-5	2		4	6 1/2	13 1/2	4 1/2
	3/4		4	6 1/2	16 1/2	4 1/2
	1		4	6 1/2	16 1/2	4 1/2
	1 1/4		4	6 1/2	16 1/2	4 1/2
	1 1/2		4	6 1/2	16 1/2	4 1/2
	2		4	6 1/2	16 1/2	4 1/2
S-6	2 1/2	2 1/2	4	6 1/2	16 1/2	4 1/2
	1 1/4		6	8	14	5 5/8
	1 1/2		6	8	14	5 5/8
	2		6	8	14	5 5/8
	2 1/2	2 1/2	6	8	14	5 5/8
S-8	3	3	6	8	14	5 5/8
	1 1/2		8	10	17	8 5/8
	2		8	10	17	8 5/8
	2 1/2	2 1/2	8	10	17	8 5/8
S-10	3	3	8	10	17	8 5/8
	4	4	8	10	17	8 5/8
	2		12	12	14	12 3/4
	2 1/2	2 1/2	12	12	14	12 3/4
S-12	3	3	12	12	14	12 3/4
	4	4	12	12	14	12 3/4
	6	6	12	12	14	12 3/4
	2 1/2	2 1/2	12	12	21	12 3/4

Notes: 1) 150# & 300# flanges available.
2) Other sizes available; consult factory.

NPT x Weld

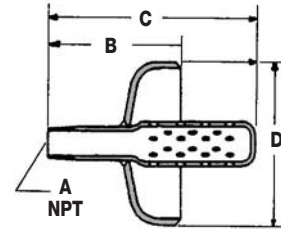

PILOT-OPERATED
REGULATING VALVES

Flanged x Weld

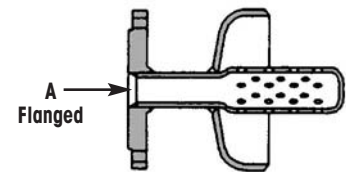

NPT x Flanged

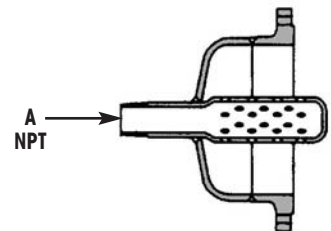

Flanged x Flanged

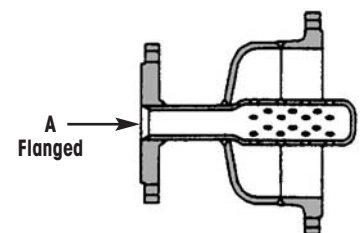

REGULATORS

HD & HSP Series

Watson McDaniel reserves the right to change the designs and/or materials of its products without notice.
©2010 Watson McDaniel Company

Full Port Regulating Valves – Capacities

PILOT-OPERATED REGULATING VALVES

CAPACITIES – Steam (lbs/hr)											FULL PORT	
Inlet Pressure (PSIG)	Outlet Pressure (PSIG)	1/2"	3/4"	1"	1 1/4"	1 1/2"	2"	2 1/2"	3"	4"	6"	
C _v Factors		3.8	6.7	11	15	21	37	55	71	113	241	
5	0	85	150	250	350	500	800	1200	1600	2600	5500	
	2	80	140	230	310	440	770	1100	1500	2400	5100	
7	0	115	200	325	450	600	1100	1650	2100	3600	7800	
	2	105	180	300	400	575	1000	1500	2000	3100	6700	
	3	90	160	275	375	525	900	1300	1800	2800	6000	
10	0	150	260	425	575	850	1500	2200	2800	4600	9900	
	2	140	240	400	550	800	1400	2100	2700	4300	9100	
	5	100	175	300	400	600	1000	1600	2000	3200	6900	
12	0	160	280	475	600	900	1600	2400	3100	4900	10300	
	4	140	240	400	550	800	1400	2100	2700	4300	9100	
	7	125	200	375	500	700	1200	1900	2400	3800	8200	
15	0-3	190	325	550	750	1000	1800	2700	3500	5600	12000	
	5	175	300	500	700	900	1700	2500	3200	5200	11100	
	8	140	250	400	500	800	1300	2000	2600	4200	8900	
20	0-5	210	375	625	850	1200	2100	3100	4000	6400	13700	
	10	190	325	550	750	1000	1800	2700	3500	5600	12000	
	12	170	300	500	675	950	1600	2500	3200	5100	10800	
25	0-7	250	450	775	1050	1500	2600	3800	5000	7900	16900	
	10	225	425	700	975	1300	2400	3600	4600	7300	15600	
	15	200	350	600	800	1100	2000	3000	3900	6200	13200	
30	0-12	275	500	800	1100	1500	2700	4100	5200	8300	17800	
	15	250	450	750	1000	1400	2500	3800	4900	7800	16600	
	20	225	375	650	850	1200	2100	3200	4100	6500	14000	
40	0-18	350	600	1000	1350	1900	3300	5000	6400	10300	21900	
	25	300	500	850	1150	1600	2800	4200	5400	8700	18500	
	30	250	425	700	1000	1400	2500	3700	4700	7600	16100	
50	0-20	400	700	1200	1650	2300	4100	6000	7800	12400	26500	
	30	350	650	1100	1500	2000	3600	5400	6900	11000	23600	
	40	275	500	800	1100	1500	2700	4100	5200	8300	17800	
60	0-30	475	850	1350	1900	2600	4600	6900	8900	14200	30300	
	35	425	775	1250	1700	2400	4300	6400	8200	13100	27900	
	50	300	525	850	1200	1600	2900	4300	5600	8900	19000	
75	0-35	575	1000	1650	2300	3200	5600	8300	10800	17200	36600	
	50	475	825	1350	1900	2600	4600	6900	8900	14100	30100	
	60	400	700	1150	1600	2200	3900	5800	7400	11800	25200	
90	0-45	675	1200	1950	2700	3700	6600	9800	12700	20200	43100	
	60	575	1000	1700	2300	3200	5700	8500	10900	17400	37100	
	75	425	750	1200	1700	2300	4100	6100	7900	12600	27000	
100	0-50	750	1300	2100	3000	4100	7300	10800	14000	22200	47500	
	60	700	1200	2000	2700	3800	6700	10000	12900	20500	43800	
	80	500	875	1400	1900	2700	4800	7100	9200	14700	31300	
125	0-60	925	1650	2700	3700	5200	9100	14000	17500	28000	59500	
	75	825	1475	2400	3300	4600	8200	12200	15700	25000	53500	
	100	625	1100	1800	2500	3500	6200	9200	11900	19000	40400	
150	0-75	1100	1900	3100	4300	6000	10600	15800	20400	32400	69100	
	100	925	1600	2700	3600	5100	9000	13400	17400	27700	59000	
	125	650	1150	1900	2600	3600	6400	9500	12300	19600	41900	
175	0-85	1275	2250	3700	5000	7100	12500	18600	24000	38200	81400	
	125	1000	1800	2900	4000	5600	9900	14700	18900	30100	64300	
	150	750	1300	2100	2900	4100	7300	10800	14000	22200	47500	
200	0-100	1450	2500	4200	5700	8000	14100	21000	27100	43100	92000	
	125	1300	2300	3700	5100	7100	12600	18700	24100	38400	81900	
	150	1075	1900	3100	4300	6000	10600	15700	20300	32300	68900	
225	0-120	1575	2800	4600	6200	8700	15400	22900	29500	47000	100200	
	150	1450	2500	4200	5700	8000	14100	21000	27200	43300	92300	
	175	1350	2400	3900	5300	7400	13100	19500	25200	40100	85500	
250	0-130	1750	3100	5100	6900	9700	17100	25500	32900	53400	111800	
	150	1650	2900	4700	6500	9100	16000	23800	30800	49000	104600	
	200	1200	2100	3500	4800	6700	11900	17600	22800	36200	77300	
300	0-160	2045	3605	5920	8075	11310	19220	29610	38230	60840	129750	
	175	1945	3425	5625	7670	10740	18925	28130	36320	57800	123270	
	200	1780	3140	5155	7030	9840	17340	25780	33275	52960	112950	

Note: For inlet pressures in shaded area, use low pressure main valve and low pressure temperature pilot.

HD & HSP Series

Reduced Port Regulating Valves – Capacities

CAPACITIES – Steam (lbs/hr)		REDUCED PORT									
Inlet Pressure (PSIG)	Outlet Pressure (PSIG)	1/2"	3/4"	1"	1 1/4"	1 1/2"	2"	2 1/2"	3"	4"	6"
C _v Factors		1.4	3.3	5.6	7.8	13.3	18.8	25.9	41.7	74	163
5	0	15	35	59	82	140	197	272	438	777	1712
	2	13	32	53	75	128	181	249	401	712	1569
7	0	21	48	82	115	195	276	381	613	1088	2396
	2	20	46	79	110	187	265	365	587	1042	2296
	3	19	44	74	104	177	250	344	554	983	2165
10	0	29	70	117	164	279	395	544	876	1554	3423
	2	28	68	115	160	274	387	533	858	1523	3354
	5	25	60	102	142	242	342	471	758	1346	2964
12	0	35	83	141	197	335	473	653	1051	1865	4108
	4	33	78	133	185	316	446	615	990	1758	3873
	7	29	68	115	160	272	385	530	854	1515	3336
15	0-3	43	102	173	241	410	580	800	1287	2284	5031
	5	41	98	166	232	395	558	769	1238	2198	4841
	8	37	88	149	208	354	500	690	1111	1972	4343
20	0-5	57	134	227	317	541	764	1053	1696	3009	6629
	10	51	120	204	284	483	684	942	1517	2692	5929
	12	47	111	188	262	447	632	870	1401	2486	5477
25	0-7	70	166	282	393	670	948	1305	2102	3730	8215
	10	67	158	269	375	640	905	1246	2006	3561	7843
	15	59	139	235	328	559	790	1088	1751	3108	6846
30	0-12	81	190	323	450	768	1085	1495	2408	4273	9411
	15	76	180	305	426	726	1025	1413	2275	4037	8892
	20	66	155	263	366	625	883	1216	1958	3475	7654
40	0-18	105	248	420	585	998	1410	1943	3128	5551	12227
	25	99	199	367	511	872	1232	1698	2734	4852	10688
	30	78	183	311	433	739	1044	1439	2317	4111	9056
50	0-20	135	318	539	751	1280	1809	2492	4013	7121	15686
	30	118	277	470	655	1117	1579	2175	3502	6216	13692
	40	88	208	353	491	838	1184	1632	2627	4662	10269
60	0-30	153	360	611	851	1451	2051	2826	4550	8074	17786
	35	143	338	573	798	1361	1924	2651	4268	7573	16682
	50	98	230	390	543	926	1309	1804	2904	5154	11353
75	0-35	195	460	780	1086	1853	2619	3608	5809	10308	22706
	50	164	387	657	916	1561	2207	3040	4895	8687	19135
	60	132	312	529	737	1257	1777	2448	3941	6993	15404
90	0-45	229	540	916	1277	2177	3077	4239	6825	12112	26680
	60	197	465	789	1100	1874	2648	3649	5874	10425	22962
	75	146	345	585	815	1389	1964	2705	4357	7731	17029
100	0-50	255	600	1018	1419	2419	3419	4710	7584	13458	29644
	60	235	554	940	1310	2234	3158	4351	7006	12432	27384
	80	176	416	706	983	1676	2367	3263	5254	9324	20538
125	0-60	322	760	1290	1796	3063	4329	5964	9603	17041	37536
	75	294	693	1176	1638	2793	3948	5439	8757	15540	34230
	100	221	518	882	1229	2095	2961	4079	6568	11655	25672
150	0-75	381	900	1527	2128	3628	5128	7065	11376	20187	44467
	100	329	775	1315	1831	3123	4414	6081	9791	17374	38270
	125	243	575	975	1385	2316	3274	4510	7261	12885	28382
175	0-85	449	1060	1800	2505	4272	6939	9320	13396	23771	52362
	125	360	849	1440	2006	3421	4835	6661	10725	19032	41923
	150	265	625	1060	1476	2518	3558	5006	7893	14008	30855
200	0-100	509	1200	2037	2837	4838	6838	9420	15168	26916	59288
	125	459	1082	1836	2557	4360	6164	8492	13672	24262	53442
	150	389	917	1556	2167	3695	5223	7195	11584	20557	45232
225	0-120	560	1319	2238	3117	5360	7514	10351	16667	29577	65150
	150	493	1162	1972	2747	4684	6621	9121	14686	26061	57405
	175	416	980	1663	2316	3950	5583	7692	12384	21976	48409
250	0-130	628	1480	2511	3498	5964	8431	11614	18700	33184	73095
	150	588	1386	2352	3276	5586	7896	10878	17514	31080	68460
	200	441	1040	1764	2457	4190	5922	8159	13136	23310	51345
300	0-160	755	1775	3015	4200	7160	10120	13945	22450	39840	87760
	175	715	1690	2865	3990	6800	9615	13250	21330	37850	83370
	200	655	1550	2625	3655	6235	8810	12140	19545	34680	76400

Note: For inlet pressures in shaded area, use low pressure main valve and low pressure temperature pilot.

PILOT-OPERATED REGULATING VALVES

Direct-Operated Pressure & Temperature Regulating Valves

Temperature Regulators

DIRECT-OPERATED REGULATING VALVES

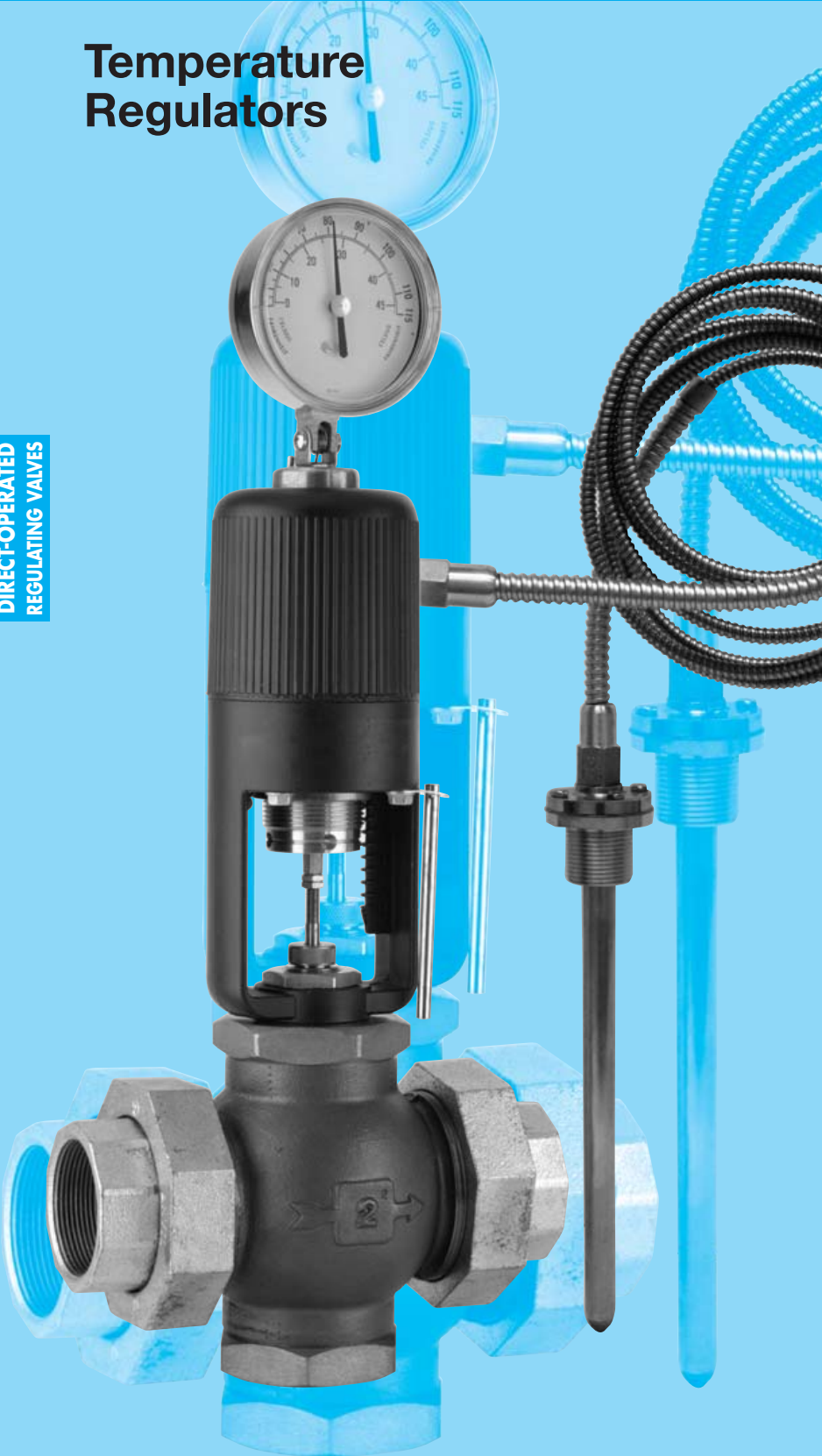

Pressure Regulators

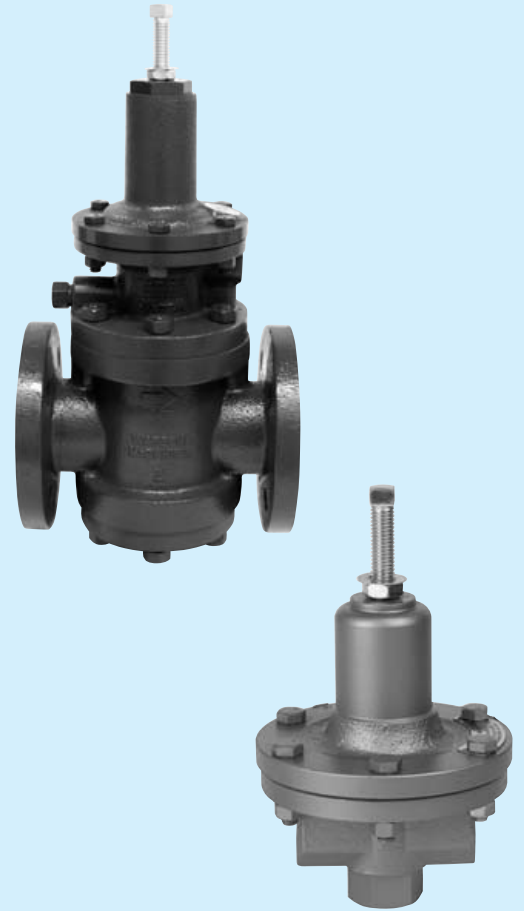

Relief Valves





Direct-Operated Pressure & Temperature Regulating Valves

Direct-Operated Regulators are used for controlling pressure and temperature in a variety of applications.

PRESSURE REGULATORS Page No.

 <p>Cast Iron 3/8" - 2"</p>	<h3>O Series</h3>	<p>Pressure Regulating Valve - STEAM, Water, Air, Oil, other Liquids & Gases</p> <p>The O Series, with Cast Iron body and Hardened Stainless internals, is our most popular and economical solution for reducing pressure in STEAM systems. It is also suitable for Air, Water, Oil as well as other Liquids and Gases.</p>	<p>154-155</p>
--	-------------------	--	-----------------------

 <p>Bronze, Cast Iron 1/2" - 4"</p>	<h3>B Series</h3>	<p>Pressure Regulating Valve - WATER, Air, Oil, other Liquids & Gases</p> <p>The B-Series is primarily used for reducing pressure in WATER systems. It is also suitable for Air, Oil, as well as other Liquids and Gases. The B-Series offers higher capacity than the O-Series.</p>	<p>156-157</p>
--	-------------------	---	-----------------------

 <p>Bronze, Cast Iron 1/2" - 4"</p>	<h3>455 Series</h3>	<p>Pressure Regulating Valve - STEAM, Air, Water & other Gases</p> <p>The 455 is ideally suited for reducing pressure in STEAM applications and requires only 5 PSIG minimum inlet pressure. Excellent for use in steam systems that contain large amounts of scale that may cause failure in pilot-operated regulators.</p> <p><i>With a slight modification to the internal mechanism, the 455 can be used for Liquid systems.</i></p>	<p>158-159</p>
--	---------------------	---	-----------------------

 <p>Ductile Iron 1/2" - 4"</p>	<h3>402 & 403 Series</h3>	<p>Pressure Regulating Valve - STEAM & Air</p> <p>The 402 & 403 are pilot-operated, piston-actuated, pressure regulators primarily used for reducing pressure in STEAM systems. This regulator can be equipped with an optional internal sensing line which simplifies installation. <i>The 403 Series has all stainless steel internals for high-pressure applications up to 450 PSIG.</i></p>	<p>160-161</p>
--	-------------------------------	--	-----------------------

**DIRECT-OPERATED
REGULATING VALVES**

BACK PRESSURE-RELIEF VALVES

 <p>Bronze 1/2" - 3"</p>	<h3>R Series & 10691 Series</h3>	<p>Relief & Back Pressure Valves - Water, Liquids & Air</p> <p>The R Series & 10691 Series are economically-priced Back Pressure Relief Valves for Liquid service. Relief Valves/Back Pressure Valves are used to maintain a specific back pressure or to protect systems from an over-pressure condition.</p>	<p>162-163</p>
---	--------------------------------------	--	-----------------------

 <p>Bronze, Cast Iron 1/2" - 2"</p>	<h3>3040 Series</h3>	<p>Relief & Back Pressure Valves - Water, Liquids & Air</p> <p>The 3040 Back Pressure Relief Valve offers a much higher capacity than the R Series. Used for Liquid service. Relief Valves protect systems from over-pressurized conditions.</p>	<p>164-165</p>
--	----------------------	--	-----------------------

TEMPERATURE REGULATING VALVES

	<h3>W91 & W94 Series</h3>	<p>Self-Operating Temperature Regulating Valves - Heating/Cooling</p>	<p>166-183</p>
---	-------------------------------	---	-----------------------

The **W91/W94 Series** Temperature Regulating Valves are used for controlling temperatures in industrial and HVAC applications.

<p>W91/W94 Design & Operation</p> <p>Typical Applications</p> <p>How to Order</p> <p>Specifications & Options</p>	<p>166-170</p> <p>171</p> <p>172</p> <p>173-183</p>
---	---

Bronze, Cast Iron
1/2" - 4"

REGULATORS

"O" Series

Pressure Regulating Valve

Watson McDaniel reserves the right to change the designs and/or materials of its products without notice.
©2010 Watson McDaniel Company

Model	"O" Series
Service	Steam, Air, Water & Other Liquids
Sizes	3/8", 1/2", 3/4", 1", 1 1/4", 1 1/2", 2"
Connections	NPT
Body Material	Cast Iron
Seat & Disc	Hardened 420 Stainless Steel
Diaphragm	Phosphor Bronze - Steam Neoprene/Nylon (composition) - Water, Air & Oil (250°F max) Viton (optional) - Water, Air & Oil (300°F max)
Max. Inlet Pressure	250 PSIG
Min. Inlet Pressure	15 PSIG
Max. Diff. Pressure	125 PSI
Min. Diff. Pressure	15 PSI



DESIGN PRESSURE/TEMPERATURE RATING – PMA/TMA

NPT 250 PSIG @ 450°F

TYPICAL APPLICATIONS

The "O" Series Pressure Regulating Valves are used for reducing pressure in steam, air and water systems. Commonly used in heating and other process applications.

HOW TO SIZE/ORDER

From the Capacity chart, find the inlet pressure and required regulator outlet pressure. Follow across chart to nearest capacity of application service medium that meets or slightly exceeds demand requirements. Follow vertically up to determine appropriate size. When exact application values are not shown, interpolation between values is acceptable. From the Spring Ranges chart, select the ideal spring range that accommodates the required outlet set pressure, confirm that system pressure requirements can be accommodated by valve. Example:

Application: 200 lbs/hr of 100 PSIG Steam reduced to 30 PSIG
Size/Model: 1/2" "O" Series, 10-50 PSIG spring range

FEATURES & OPTIONS

- Hardened stainless steel seat and disc for extended service life (55 Rc)
- Neoprene & Nylon (composition) fiber diaphragm for water, oil and air service; 250°F maximum temperature
- Viton diaphragm for up to 300°F service for water, oil & air service
- Phosphor Bronze diaphragm for steam service; Neoprene for water, oil & air
- Double spring available for extended outlet pressure range
- Integral stainless steel strainer on 3/4" HC, 1", 1 1/4", 1 1/2" & 2"

PRESSURE-ADJUSTING SPRING RANGES – Spring No. & Color Code

	Outlet Pressure	Size							
		3/8"	1/2"	3/4"	3/4" HC	1"	1 1/4"	1 1/2"	2"
Single Spring	0-10	13 blue/yellow	13 blue/yellow	13 blue/yellow	3 red	7 red/green	7 red/green	8 red/blue	8 red/blue
	10-30	–	–	–	4 green	8 red/blue	8 red/blue	9 red/yellow	9 red/yellow
	10-50	14 black/yellow	14 black/yellow	14 black/yellow	–	–	–	–	–
	30-50	–	–	–	5 blue	9 red/yellow	9 red/yellow	10 green/blue	10 green/blue
	40-85	–	–	–	6 yellow	10 green/blue	10 green/blue	11 green/yellow	11 green/yellow
	40-100	9 red/yellow	9 red/yellow	9 red/yellow	–	–	–	–	–
	100-200	10 green/blue	10 green/blue	10 green/blue	–	–	–	–	–
Double Spring	0-75	–	–	–	7, red/green 8, red/blue	8, red/blue 9, red/yellow	8, red/blue 9, red/yellow	8, red/blue 9, red/yellow	8, red/blue 9, red/yellow
	30-130	–	–	–	8, red/blue 9, red/yellow	9, red/yellow 10, green/blue	9, red/yellow 10, green/blue	9, red/yellow 10, green/blue	9, red/yellow 10, green/blue

REGULATORS

"O" Series Pressure Regulating Valve

DIMENSIONS & WEIGHTS – inches/pounds

Size	A	B	C	C Double Spring	Weight (lbs)
3/8"	4 1/4	6 1/2	8	-	8
1/2"	3 5/8	6 1/2	8	-	8
3/4"	3 5/8	6 1/2	8	-	8
3/4" HC	3 5/8	8	10	12 1/2	15
1"	4 1/2	8 1/2	10 1/2	13	18
1 1/4"	4 1/2	8 1/2	10 1/2	13	18
1 1/2"	6 1/2	8 3/4	12	14 1/2	40
2"	6 1/2	8 3/4	12	14 1/2	40

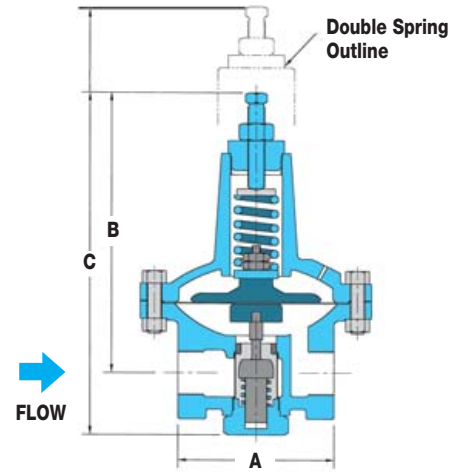

CAPACITIES – Steam (lbs/hr); *Air (SCFM); *Water (GPM)

Inlet/Outlet Pressures (PSIG)

Inlet Press.	Outlet Press.	3/8", 1/2", 3/4"			3/4" HC **			1"			1 1/4"			1 1/2"			2"		
		Steam	Air	Water	Steam	Air	Water	Steam	Air	Water	Steam	Air	Water	Steam	Air	Water	Steam	Air	Water
15	2	46	26	6	92	51	11	130	73	16	145	81	18	180	100	22	199	111	25
	5	38	21	4	75	42	9	106	59	13	119	66	14	147	82	18	163	91	19
20	5	65	36	8	130	72	15	184	102	22	205	114	25	254	141	30	281	156	34
	10	61	34	6	123	69	13	174	97	18	194	109	20	241	134	25	266	149	27
30	15	45	25	4	90	51	9	128	72	13	143	80	14	177	99	18	196	109	19
	5	83	46	10	167	93	20	236	131	28	264	147	32	327	181	39	362	201	43
	10	83	46	10	167	93	18	236	131	25	264	147	28	327	181	35	362	201	39
50	20	71	40	6	142	79	13	201	112	18	225	126	20	278	155	25	308	172	27
	5	121	67	13	242	134	27	342	190	38	382	212	42	473	263	53	523	291	58
	25	121	67	10	242	134	20	342	190	28	382	212	32	473	263	39	523	291	43
100	40	87	49	6	174	97	13	247	138	18	276	154	20	341	191	25	377	211	27
	30	214	119	17	428	238	33	607	337	47	678	376	53	839	466	66	928	515	73
	50	214	119	14	428	238	28	607	337	40	678	376	45	839	466	55	928	515	61
125	70	195	109	11	275	154	18	390	218	25	436	244	28	540	301	35	597	333	39
	30	261	145	19	522	290	39	739	410	55	826	458	62	1021	567	76	1130	627	84
	50	261	145	17	522	290	35	739	410	49	826	458	55	1021	567	68	1130	627	75
150	70	261	145	15	522	290	30	739	410	42	826	458	47	1021	567	58	1130	627	64
	100	201	112	10	402	225	20	569	318	28	636	355	32	787	440	39	871	486	43
	30	307	171	22	615	341	44	871	484	62	974	540	69	1204	668	86	1332	740	95
200	50	307	171	20	615	341	40	871	484	57	974	540	63	1204	668	78	1332	740	87
	70	307	171	18	615	341	36	871	484	51	974	540	57	1204	668	70	1332	740	78
	100	298	166	14	596	333	28	844	471	40	943	527	45	1167	652	55	1291	721	61
250	120	239	133	11	478	267	22	677	378	31	756	422	35	935	523	43	1035	578	47
	30	401	222	26	802	445	52	1135	630	74	1269	705	83	1570	871	102	1737	964	113
	50	401	222	24	802	445	49	1135	630	69	1269	705	78	1570	871	96	1737	964	106
250	70	401	222	23	802	445	46	1135	630	65	1269	705	72	1570	871	89	1737	964	99
	100	401	222	20	802	445	40	1135	630	57	1269	705	63	1570	871	78	1737	964	87
	50	494	274	28	988	549	57	1400	777	80	1565	869	90	1935	1074	111	2141	1189	123
250	70	494	274	27	988	549	54	1400	777	76	1565	869	85	1935	1074	105	2141	1189	116
	125	494	274	22	988	549	45	1400	777	63	1565	869	71	1935	1074	88	2141	1189	97

* Air and water capacities are based on using elastomeric diaphragms.

** 3/4" HC is high-capacity version of standard 3/4" valve.

Note: For capacities of other gases multiply the air capacities by the following factors: Argon-0.85 CO₂-0.81 Helium-2.69 Nitrogen-1.02

DIRECT-OPERATED
REGULATING VALVES

REGULATORS

B Series

Pressure Regulating Valve

Watson McDaniel reserves the right to change the designs and/or materials of its products without notice.
©2010 Watson McDaniel Company

DIRECT-OPERATED REGULATING VALVES

Model	B Series
Service	Water, Air, Oil, Other Gases & Liquids
Sizes	1/2", 3/4", 1", 1 1/4", 1 1/2", 2", 2 1/2", 3", 4"
Connections	NPT, 125# & 250# Flanged
Body Material	1/2"– 2 1/2" Bronze 3" & 4" Cast Iron
Disc	Neoprene (standard) - 200°F max Viton (optional) - 300°F max
Diaphragm	Neoprene/Nylon - 200°F max Viton (optional) - 300°F max
Max. Inlet Pressure	250 PSIG
Min. Inlet Pressure	10 PSIG
Max. Diff. Pressure	125 PSI
Min. Diff. Pressure	20% of Inlet Pressure

DESIGN PRESSURE/TEMPERATURE RATING – PMA/TMA

NPT	250 PSIG @ 400°F
125# FLG	125 PSIG @ 450°F
250# FLG	250 PSIG @ 450°F

TYPICAL APPLICATION

The **B Series** Pressure Regulating Valves are used for reducing pressure in air and water systems. These regulators are commonly found in industrial plants, apartment buildings, water supply systems, schools and underground water distribution systems.

FEATURES & OPTIONS

- Diaphragm, disc and cup packing available in Viton for 300°F service (optional)
- Balanced pressure regulator allows accurate control even when incoming pressure fluctuates
- Internally senses pressure – no external sensing line required
- Soft disc in Neoprene or Viton for Class-V shut-off rating

HOW TO SIZE/ORDER

From the Capacity chart, find the inlet pressure and required regulator outlet pressure. Follow across chart to nearest capacity of application service medium that meets or slightly exceeds demand requirements. Follow vertically up to determine appropriate size. When exact application values are not shown, interpolation between values is acceptable. From the Spring Ranges chart, select the ideal spring range that accommodates the required outlet set pressure. Confirm that system pressure requirements can be accommodated by valve. Example:

Application: 35 GPM of 70 PSIG Water reduced to 20 PSIG
Size/Model: 1" B-Series, 5-35 PSIG spring range



PRESSURE-ADJUSTING SPRING RANGES

Outlet Pressure (PSIG)	Spring No.
1-12	4*
5-35	3
20-70	2
40-125	1

* 1/2" – 1" only

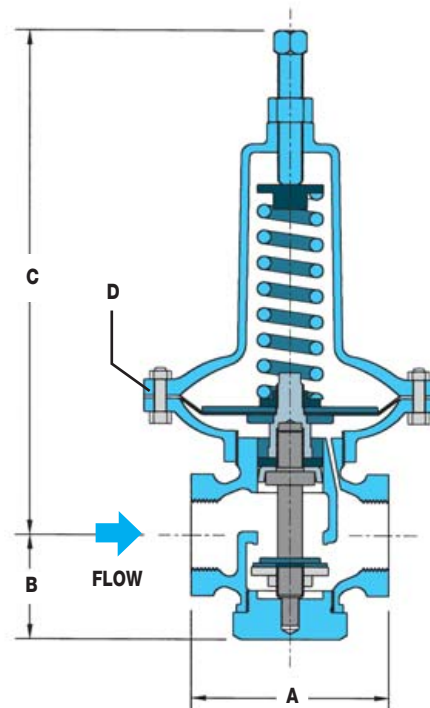

REGULATORS

B Series

Pressure Regulating Valves

DIMENSIONS & WEIGHTS – inches/pounds

Size	Face-to-Face A			B	C	D Spring Case Dia. (in.)	Weight (lbs)
	NPT Threaded	125# Flanged	250# Flanged				
1/2", 3/4"	3 ³ / ₈			1 ⁷ / ₈	9	5	7
1"	3 ⁵ / ₈			2 ¹ / ₄	9 ¹ / ₂	5	8
1 ¹ / ₄ "	4 ¹ / ₄			2 ³ / ₈	10 ¹ / ₂	6 ³ / ₄	13
1 ¹ / ₂ "	4 ³ / ₄			2 ¹ / ₂	10 ³ / ₄	6 ³ / ₄	15
2"	5 ⁷ / ₈			3 ³ / ₈	11 ⁵ / ₈	6 ³ / ₄	20
2 ¹ / ₂ "	6 ¹ / ₂			4 ¹ / ₄	12 ³ / ₄	6 ³ / ₄	30
3"		10 ¹ / ₄	11	4 ¹ / ₂	21 ¹ / ₂	9 ¹ / ₄	125
4"		13	13 ⁵ / ₈	5 ³ / ₄	23	9 ¹ / ₄	182

DIRECT-OPERATED
REGULATING VALVES

CAPACITIES – Water (GPM); Air (SCFM)

Inlet/Outlet Pressures (PSIG)

Inlet Press.	Outlet Press.	1/2"		3/4"		1"		1 ¹ / ₄ "		1 ¹ / ₂ "		2"		2 ¹ / ₂ "		3"		4"	
		Water	Air	Water	Air	Water	Air	Water	Air	Water	Air	Water	Air	Water	Air	Water	Air	Water	Air
10	5	5.5	25	10	45	13	60	22	100	33	150	55	250	88	400	132	600	176	800
	20	9.8	48	18	86	23	114	39	190	59	285	98	475	156	760	234	1140	312	1520
20	10	8.0	43	14	77	19	102	32	170	48	255	80	425	128	680	192	1020	256	1360
	15	5.5	30	10	54	13	72	22	120	33	180	55	300	88	480	132	720	176	960
30	5	12.5	68	23	122	30	162	50	270	75	405	125	675	200	1080	300	1620	400	2160
	10	11.3	63	20	113	27	150	45	250	68	375	113	625	180	1000	270	1500	360	2000
50	20	8.0	48	14	86	19	114	32	190	48	285	80	475	128	760	192	1140	256	1520
	5	16.8	98	30	176	40	234	67	390	101	585	168	975	268	1560	402	2340	536	3120
50	25	12.5	88	23	158	30	210	50	350	75	525	125	875	200	1400	300	2100	400	2800
	40	8.0	63	14	113	19	150	32	250	48	375	80	625	128	1000	192	1500	256	2000
70	10	19.3	128	35	230	46	306	77	510	116	765	193	1275	308	2040	462	3060	616	4080
	30	15.8	125	28	225	38	300	63	500	95	750	158	1250	252	2000	378	3000	504	4000
100	50	11.3	95	20	171	27	228	45	380	68	570	113	950	180	1520	270	2280	360	3040
	30	21.0	175	38	315	50	420	84	700	126	1050	210	1750	336	2800	504	4200	672	5600
100	50	17.5	165	32	297	42	396	70	660	105	990	175	1650	280	2640	420	3960	560	5280
	70	13.8	135	25	243	33	324	55	540	83	810	138	1350	220	2160	330	3240	440	4320
125	30	24.3	213	44	383	58	510	97	850	146	1275	243	2125	388	3400	582	5100	776	6800
	50	21.5	213	39	383	52	510	86	850	129	1275	215	2125	344	3400	516	5100	688	6800
150	100	12.5	140	23	252	30	336	50	560	75	840	125	1400	200	2240	300	3360	400	4480
	30	27.5	250	50	450	66	600	110	1000	165	1500	275	2500	440	4000	660	6000	880	8000
150	50	25.0	250	45	450	60	600	100	1000	150	1500	250	2500	400	4000	600	6000	800	8000
	100	17.5	205	32	369	42	492	70	820	105	1230	175	2050	280	3280	420	4920	560	6560
200	125	12.5	153	23	275	30	366	50	610	75	915	125	1525	200	2440	3000	3660	400	4880
	70	28.5	325	51	585	68	780	114	1300	171	1950	285	3250	456	5200	684	7800	912	10400
250	100	25.0	263	45	473	60	630	100	1050	150	1575	250	2625	400	4200	600	6300	800	8400
	125	21.5	223	39	401	52	534	86	890	129	1335	215	2225	344	3560	516	5340	688	7120
250	100	30.8	403	55	725	74	966	123	1610	185	2415	308	4025	492	6440	738	9660	984	12880
	125	28.0	393	50	707	67	942	101	1570	168	2355	280	3925	448	6280	672	9420	896	12560

Note: For capacities of other gases multiply the air capacities by the following factors: Argon-0.85 CO₂-0.81 Helium-2.69 Nitrogen-1.0

REGULATORS

455 Series

Pressure Regulating Valve

Watson McDaniel reserves the right to change the designs and/or materials of its products without notice.
©2010 Watson McDaniel Company

Model	455 Series
Service	Steam, Water, Air & Other Gases
Sizes	1/2", 3/4", 1", 1 1/4", 1 1/2", 2", 2 1/2", 3", 4"
Connections	NPT, 125# & 250# Flanges
Body Material	1/2" - 1 1/2" Bronze 2" - 4" Cast Iron
Seat & Disc	Stainless Steel
Diaphragm	Neoprene/Nylon
Max. Inlet Pressure	250 PSIG
Min. Inlet Pressure	5 PSIG
Max. Diff. Pressure	125 PSI
Min. Diff. Pressure	20% of Inlet Pressure



DESIGN PRESSURE/TEMPERATURE RATING – PMA/TMA

NPT	250 PSIG @ 400°F
125# FLG	125 PSIG @ 450°F
250# FLG	250 PSIG @ 450°F

PRESSURE-ADJUSTING SPRING RANGES

Size	Outlet Pressure (PSIG)	Spring No.	Spring Case Dia. (in.)
1/2" - 1 1/2"	1-6	5	6
	5-20	3	6
	15-45	2	6
	40-70	1	6
	60-125	1	5
2" - 4"	1-6	4	13
	5-20	4	9
	15-45	3	9
	40-70	3	7
	60-125	2	7

TYPICAL APPLICATIONS

The **455 Series** are balanced, Externally-Sensed Pressure Regulating Valves are used for reducing pressure in steam, air and water systems. Commonly used in heating and other process applications. Externally-sensed regulators are often more accurate than internally-sensed regulators because the sensing line is connected close to the process it is intending to control and is far enough away from the outlet of the regulator to not be affected by turbulence.

HOW TO SIZE/ORDER

From the Capacity chart, find the inlet pressure and required regulator outlet pressure. Follow across chart to nearest capacity of application service medium that meets or slightly exceeds demand requirements. Follow vertically up to determine appropriate size. When exact application values are not shown, interpolation between values is acceptable. From the Spring Ranges chart, select the ideal spring range that accommodates the required outlet set pressure. Confirm that system pressure requirements can be accommodated by valve. Example:

Application: 1000 lbs/hr of 20 PSIG Steam reduced to 5 PSIG
Size/Model: 1 1/2" **455-Series, 1-6 PSIG spring range**

FEATURES

- Operates with minimum inlet pressures of 5 PSIG
- Stainless steel internals
- Excellent for use in steam systems that contain large amounts of scale and other contamination
- Balance valve for more precise control of downstream pressure

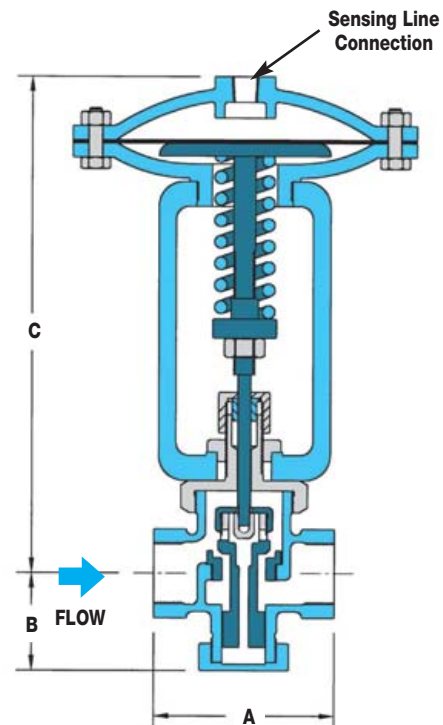

REGULATORS

455 Series

Pressure Regulating Valve

DIMENSIONS & WEIGHTS – inches/pounds

Size	Face-to-Face A			B	C	Sensing Line Connection NPT	Weight (lbs)
	NPT Threaded	125# Flanged	250# Flanged				
1/2"	4 1/4			2 3/8	10 1/4	1/4"	15
3/4"	4 1/4			2 3/8	10 1/4	1/4"	15
1"	4 1/8			2 3/8	10 1/4	1/4"	15
1 1/4"	5			3 1/8	10 3/4	1/4"	18
1 1/2"	5 1/4			3 3/8	11	1/4"	20
2"	9 1/2	10 3/8	10 7/8	5 3/4	18 1/2	3/8"	75
2 1/2"		10 5/8	11 1/4	6 1/4	18 3/4	3/8"	95
3"		10 7/8	11 5/8	7 1/8	19 1/4	3/8"	135
4"		12 1/2	13 1/8	8 1/4	20	3/8"	158

DIRECT-OPERATED
REGULATING VALVES

CAPACITIES – Steam (lbs/hr); Water (GPM)

Inlet/Outlet Pressures (PSIG)

Inlet Press.	Outlet Press.	1/2"		3/4"		1"		1 1/4"		1 1/2"		2"		2 1/2"		3"		4"	
		Steam	Water	Steam	Water	Steam	Water	Steam	Water	Steam	Water	Steam	Water	Steam	Water	Steam	Water	Steam	Water
5	2	53	4.3	95	7.8	191	15.6	276	22.5	403	33.0	572	47.0	890	73.0	1166	95.0	1484	121
	10	95	7.1	171	12.7	342	25.0	494	37.0	722	54.0	1026	76.0	1596	119	2090	156	2660	198
20	5	73	5.6	131	10.1	263	20.0	380	29.0	555	42.0	788	60.0	1226	94.0	1606	123	2044	157
	0-5	157	9.7	283	17.4	565	35.0	816	50.0	1193	75.0	1696	105	2638	163	3454	213	4396	271
30	10	125	7.9	225	14.2	450	28.0	650	41.0	950	60.0	1350	85.0	2100	133	2750	174	3500	221
	0-10	200	11.2	360	20.1	720	40.0	1040	58.0	1520	85.0	2160	121	3360	188	4400	246	5600	313
50	20	145	7.9	261	14.2	522	28.0	754	41.0	1102	60.0	1566	85.0	2436	133	3190	174	4060	221
	25	107	5.6	193	10.1	385	20.0	556	29.0	813	42.0	1156	60.0	1798	94.0	2354	123	2996	157
	0-20	295	13.7	531	24.6	1062	49.0	1534	71.0	2242	104	3186	148	4956	230	6490	301	8260	383
75	30	245	11.2	441	20.1	882	40.0	1274	58.0	1862	85.0	2646	121	4116	188	5390	247	6860	313
	40	185	7.9	333	14.2	666	28.0	962	41.0	1406	60.0	1998	85.0	3108	133	4070	174	5180	221
	0-30	402	16.8	724	30.2	1447	60.0	2090	87.0	3055	127	4342	181	6754	282	8844	369	11256	470
100	50	327	12.5	589	22.5	1177	45.0	1700	65.0	2485	95.0	3532	135	5494	210	7194	275	9156	350
	60	255	9.7	459	17.4	918	35.0	1326	50.0	1938	74.0	2754	105	4284	163	5610	213	7140	271
	0-50	522	17.7	940	31.8	1879	64.0	2714	92.0	3967	134	5638	191	8770	297	11484	389	14616	495
125	60	455	15.8	819	28.5	1638	57.0	2366	82.0	3458	120	4914	171	7644	266	10010	348	12740	443
	80	325	11.2	585	20.1	1170	40.0	1690	58.0	2470	85.0	3510	121	5460	188	7150	246	9100	313
	0-60	635	20.2	1143	36.3	2286	73.0	3302	105	4826	153	6858	218	10668	339	13970	443	17780	564
150	70	575	18.5	1035	33.4	2070	67.0	2990	96.0	4370	141	6210	200	9660	311	12650	408	16100	519
	100	420	12.5	756	22.5	1512	45.0	2184	65.0	3192	95.0	4536	135	7056	210	9240	275	11760	350
	0-70	750	22.4	1350	40.2	2700	80.0	3900	116	5700	170	8100	241	12600	376	16500	492	21000	626
200	100	612	17.7	1102	31.8	2203	64.0	3182	92.0	4651	134	6610	191	10282	297	13464	389	17136	495
	125	435	12.5	783	22.5	1566	45.0	2262	65.0	3306	95	4698	135	7308	210	9570	275	12180	350
	0-100	977	25.0	1759	45.0	3517	90.0	5080	130	7425	190	10552	270	16414	420	21494	550	27356	700
250	125	850	21.7	1530	39.0	3060	78.0	4420	113	6460	165	9180	234	14280	364	18700	476	23800	606
0-125	1180	28.0	2124	50.3	4248	101	6136	145	8968	212	12744	302	19824	470	25960	615	33040	783	

Note: Air in SCFM (Standard Cubic Feet per Minute) = Steam (lbs/hr) x 0.36

REGULATORS

402 & 403 Series

Pressure Regulating Valve

Watson McDaniel reserves the right to change the designs and/or materials of its products without notice.
©2010 Watson McDaniel Company

Model	402	403
Service	Steam & Air	
Sizes	1/2", 3/4", 1", 1 1/4", 1 1/2", 2", 2 1/2", 3", 4"	
Connections	NPT, 150# & 300# Flanged	
Body Material	Ductile Iron	
Seat & Disc	Hardened 420 Stainless Steel (55 Rc)	
Max. Inlet Pressure	250 PSIG	450 PSIG
Min. Inlet Pressure	20 PSIG	20 PSIG
Max. Diff. Pressure	150 PSI	250 PSI
Min. Diff. Pressure	15% of Inlet Pressure (10 PSI min)	



402/403
Flanged

DESIGN PRESSURE/TEMPERATURE RATING – PMA/TMA

NPT	450 PSIG @ 650°F
150# FLG	150 PSIG @ 566°F
300# FLG	450 PSIG @ 650°F

TYPICAL APPLICATIONS

The **402** and **403** Series Internally Pilot-Operated Pressure Regulating Valves are used for pressure reduction on steam mains and other process equipment. Pilot-operated regulators will maintain a constant and accurate downstream pressure regardless of fluctuations in supply pressure or usage. These regulators can be supplied with an internal sensing option eliminating the external sensing line.

FEATURES & OPTIONS

- Internal pilot minimizes outlet pressure fluctuations. Outlet pressure remains constant even when load varies
- Internal Sensing option (If requested the regulator can be modified to internally sense pressure eliminating the need for an external sensing line)
- Ductile Iron body to handle increased pressure and temperature
- Hardened stainless steel seat and disc (55 Rc)
- 403 Series regulators use stainless steel wear parts for a higher operating pressure rating (PMO of 450 PSIG)

HOW TO SIZE/ORDER

From the Capacity chart, find the inlet pressure and required regulator outlet pressure. Follow across chart to nearest capacity of application service medium that meets or slightly exceeds demand requirements. Follow vertically up to determine appropriate size. When exact application values are not shown, interpolation between values is acceptable. From the Spring Ranges chart, select the ideal spring range that accommodates the required outlet set pressure. Select valve model suitable for system pressure requirements. Specify Internal or External (Remote) sensing. Example:

Application: 12,500 lbs/hr of 300 PSIG Steam reduced to 125 PSIG
Size/Model: 2" 403 Series Valve, 100-200 PSIG spring range, Specify internal or external sensing

PRESSURE-ADJUSTING SPRING RANGES

Springs	Outlet Pressure (PSIG)	Spring No.	Identifying Colors
Single	0-10	13	blue/yellow
	10-50	14	black/yellow
	40-100	9	red/yellow
	100-200	10	green/blue
	200-280	special	bellville washers
Double	30-125	14	black/yellow
		9	red/yellow
	50-200	9	red/yellow
		10	green/blue

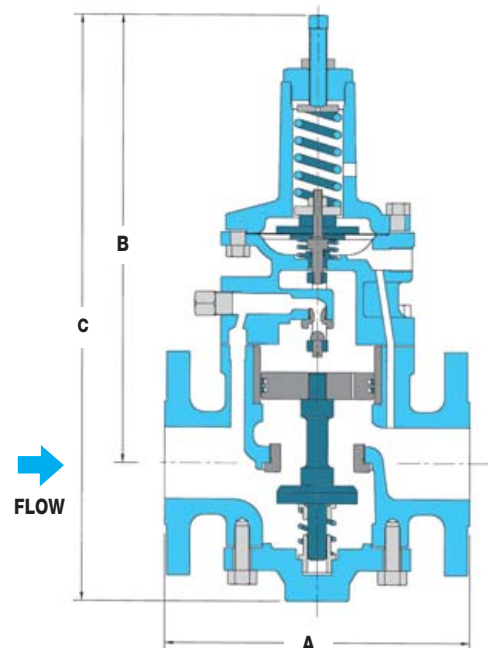

402 & 403 Series Pressure Regulating Valve

DIMENSIONS & WEIGHTS – inches/pounds

Size	Face-to-Face A			Centerline to Top B		Overall Height C		Weight (lbs)
	NPT Threaded	150# Flanged	300# Flanged	Single Spring	Double Spring	Single Spring	Double Spring	
1/2"	4 ¹ / ₂			12	14 ³ / ₈	14 ³ / ₈	16 ³ / ₄	19
3/4"	4 ¹ / ₂			12	14 ³ / ₈	14 ³ / ₈	16 ³ / ₄	19
1"	4 ¹ / ₂			12	14 ³ / ₈	14 ³ / ₈	16 ³ / ₄	19
1 1/4"	8 ³ / ₁₆			12 ³ / ₄	15 ¹ / ₈	16 ¹ / ₈	18 ¹ / ₂	36
1 1/2"	8 ³ / ₁₆			12 ³ / ₄	15 ¹ / ₈	16 ¹ / ₈	18 ¹ / ₂	36
2"	8 ³ / ₄	8 ¹ / ₄	8 ³ / ₄	13	15 ³ / ₈	17 ¹ / ₈	19 ¹ / ₂	50
2 1/2"		9 ¹ / ₈	9 ³ / ₄	13 ³ / ₄	16 ¹ / ₈	18 ¹ / ₄	20 ⁵ / ₈	70
3"		9 ³ / ₄	10 ¹ / ₂	14 ³ / ₄	16 ¹ / ₈	19 ³ / ₄	22 ¹ / ₈	82
4"		13 ¹ / ₂	14	16	18 ³ / ₈	24	26 ³ / ₈	170

DIRECT-OPERATED
REGULATING VALVES

CAPACITIES – Steam (lbs/hr); Air (SCFM)

Inlet/Outlet Pressures (PSIG)

Inlet Press.	Outlet Press.	1/2", 3/4"		1"		1 1/4"		1 1/2"		2"		2 1/2"		3"		4"	
		Steam	Air	Steam	Air	Steam	Air	Steam	Air	Steam	Air	Steam	Air	Steam	Air	Steam	Air
20	0-10	175	60	425	145	600	204	850	289	1300	442	2750	935	3850	1309	4900	1666
	0-10	270	88	655	213	924	300	1309	425	2002	650	4235	1375	5929	1925	7546	2450
30	20	203	67	493	162	696	228	986	323	1508	494	3190	1045	4466	1463	5684	1862
	0-20	385	130	935	315	1320	444	1870	629	2860	962	6050	2035	8470	2849	10780	3626
50	30	343	116	833	281	1176	396	1666	561	2548	858	5390	1815	7546	2541	9604	3234
	0-50	690	231	1675	561	2364	792	3349	1122	5122	1716	10835	3630	15169	5082	19306	6468
100	60	637	214	1547	519	2184	732	3094	1037	4732	1586	10010	3355	14014	4697	17836	5978
	80	455	151	1105	366	1560	516	2210	731	3380	1118	7150	2365	10010	3311	12740	4214
125	0-60	865	287	2100	697	2964	984	4199	1394	6422	2132	13585	4510	19019	6314	24206	8036
	70	805	270	1955	655	2760	924	3910	1309	5980	2002	12650	4235	17710	5929	22540	7546
150	100	588	196	1428	476	2016	672	2856	952	4368	1456	9240	3080	12936	4312	16464	5488
	0-70	1019	343	2474	833	3492	1176	4947	1666	7566	2548	16005	5390	22407	7546	28518	9604
200	100	858	287	2083	697	2940	984	4165	1394	6370	2132	13475	4510	18865	6314	24010	8036
	125	609	214	1479	519	2088	732	2958	1037	4524	1586	9570	3355	13398	4697	17052	5978
250	0-100	1337	445	3247	1080	4584	1524	6494	2159	9932	3302	21010	6985	29414	9779	37436	12446
	150	1001	333	2431	808	3432	1140	4862	1615	7436	2470	15730	5225	22022	7315	28028	9310
300	175	739	245	1794	595	2532	840	3587	1190	5486	1820	11605	3850	16247	5390	20678	6860
	0-125	1652	550	4012	1335	5664	1884	8024	2669	12272	4082	25960	8635	36344	12089	46256	15386
400	175	1358	452	3298	1097	4656	1548	6596	2193	10088	3354	21340	7095	29876	9933	38024	12642
	200	1138	378	2763	918	3900	1296	5525	1836	8450	2808	17875	5940	25025	8316	31850	10584
450	0-150	2016	665	4896	1615	6912	2280	9792	3230	14976	4940	31680	10450	44352	14630	56448	18620
	200	2016	665	4896	1615	6912	2280	9792	3230	14976	4940	31680	10450	44352	14630	56448	18620
500	250	1250	417	3035	1012	4284	1428	6069	2023	9282	3094	19635	6545	27489	9163	34986	11662
	0-200	2657	875	6452	2125	9108	3000	12903	4250	19734	6500	41745	13750	58443	19250	74382	24500
600	280	2146	711	5211	1726	7356	2436	10421	3451	15938	5278	33715	11165	47201	15631	60074	19894
	0-225	2975	984	7225	2389	10200	3372	14450	4777	22100	7306	46750	15455	65450	21637	83300	27538
700	280	2975	984	7225	2389	10200	3372	14450	4777	22100	7306	46750	15455	65450	21637	83300	27538

Note: For capacities of other gases multiply the air capacities by the following factors: Argon-0.85 CO₂-0.81 Helium-2.69 Nitrogen-1.02

BACK PRESSURE-RELIEF VALVES

R Series & 10691

Watson McDaniel reserves the right to change the designs and/or materials of its products without notice.
©2010 Watson McDaniel Company

Relief & Back-Pressure Regulating Valves

Model	R Series & *10691 Series
Service	Liquids
Sizes	1/2", 3/4", 1", 1 1/4", 1 1/2", 2", 3"
Connections	NPT
Body & Seat Material	Body: Bronze Seat: Bronze or EPDM*
Valve Material	Stainless Steel (1/2" – 1 1/2") Bronze (2" – 3")
Max. Inlet Pressure	300 PSIG

* For tight shut-off, use Model 10691 with EPDM soft seat. Available in 1/2", 3/4" & 1" sizes only.



Series 10691
Relief Valve has Soft EPDM Seat for tight shut-off in sizes 1/2", 3/4" & 1"

DESIGN PRESSURE/TEMPERATURE RATING – PMA/TMA

NPT 300 PSIG @ 180°F

PRESSURE-ADJUSTING SPRING RANGES

Relief Pressure (PSIG)	Spring No. – Color
1-6 (R only)	4, yellow*
5-35	3, silver
25-100	2, blue
75-300	1, red

*1/2" – 1 1/2" only

TYPICAL APPLICATIONS

The **R Series & 10691 Series** Back Pressure Relief Valves are used in the following applications:

- Water pump bypass for irrigation, sprinkler systems on golf courses, fountains and fire protection systems
- Fuel oil pump bypass on commercial systems or large residential systems

Caution: Not to be used as an emergency or safety relief valve.

FEATURES & OPTIONS

- **Four Springs** – easily interchanged to cover pressures from 1 to 300 PSIG
- **Heavy-duty bronze valve body**
- **10691 Series has EPDM Seat** for tight shut-off (1/2" - 1")

PRESSURE ADJUSTMENT

To adjust set pressure of valve, remove top cap, loosen lock nut and adjust pressure with steel setting screw. Rotating the screw clockwise increases the compression on the spring thereby increasing the set pressure. Rotating the screw counter-clockwise lowers the set pressure. Tighten the lock nut and replace top cap and gasket when desired set pressure is reached.

HOW TO SIZE/ORDER

- Specify:
- Regulator: **R-Series** or **10691**
 - Size based on capacity chart
 - Spring range or relief pressure

Examples: **1" R-Series – 5-35 PSIG relief pressure range**
1" R-Series – 20 PSIG (factory set)

Note: Units are not factory set unless specified.

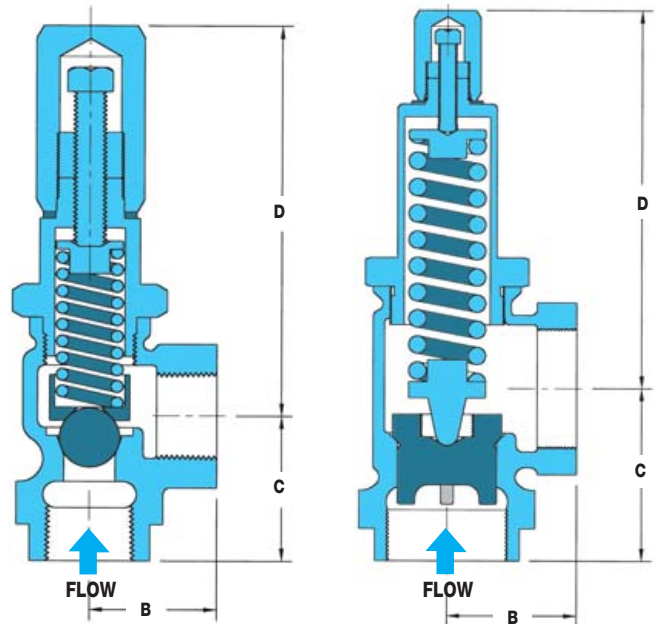

1/2" thru 1 1/2"

2" & 3"

DIMENSIONS & WEIGHTS – inches/pounds

Size	B	C	D	Weight (lbs)
1/2"	1 1/8	1 1/2	3 5/8	1.5
3/4"	1 3/8	1 3/4	5 1/2	2
1"	1 5/8	2 1/4	6	3
1 1/4"	1 7/8	2 3/8	6	6
1 1/2"	2 3/16	2 5/8	6 7/8	8
2"	2 1/2	2 5/16	8 3/4	10
3"	3 7/8	4 1/8	10 7/8	25

Note: Model 10691 available only in sizes 1/2" thru 1".

DIRECT-OPERATED
REGULATING VALVES

BACK PRESSURE-RELIEF VALVES

R Series & 10691

Relief & Back-Pressure Regulating Valves

CAPACITIES – Water (GPM)

At 10% Over Set Pressure								
Spring Range (PSIG)	Set Pressure (PSIG)	1/2"	3/4"	1"	1 1/4"	1 1/2"	2"	3"
1-6	3	1.2	2.2	3.2	4.3	5.4	-	-
5-35	10	0.3	0.4	0.4	0.5	0.5	0.6	0.7
5-35	20	0.6	0.7	0.8	1.0	1.1	1.3	1.6
25-100	50	1.0	1.3	1.6	1.8	2.2	2.6	3.2
25-100	75	1.4	1.9	2.3	2.8	3.4	4.0	5.0
75-300	100	1.9	2.5	3.2	3.8	4.6	5.4	6.9
75-300	200	3.4	4.4	5.8	6.9	8.2	9.7	12.3

At 20% Over Set Pressure								
Spring Range (PSIG)	Set Pressure (PSIG)	1/2"	3/4"	1"	1 1/4"	1 1/2"	2"	3"
1-6	3	2.2	3.4	4.6	5.8	7.1	-	-
5-35	10	0.6	0.8	1.1	1.3	1.4	1.8	2.2
5-35	20	1.4	1.9	2.4	3.0	3.4	4.1	4.8
25-100	50	1.8	2.0	3.1	3.8	4.4	5.4	6.4
25-100	75	2.3	3.2	4.0	4.8	5.6	6.9	8.1
75-300	100	3.6	4.2	5.0	6.3	7.0	7.3	8.9
75-300	200	6.5	7.6	9.0	11.2	12.4	13.1	16.0

DIRECT-OPERATED
REGULATING VALVES

The R Series Relief Valve water capacities at both 10% and 20% over "Set Pressure" are tabulated in the above table. Enter the chart at the desired "Set Pressure" in the gray column and read the capacity in GPM to determine proper Valve Size. Select a spring with a relief range that includes the "Set Pressure" required. **Example: A 1" valve set at 50 PSIG will pass 3.1 GPM if the system pressure exceeds the set point by 20%.**

HOW IT WORKS

The Relief Valve is actuated by the system pressure on the inlet side of the valve. Valve loading is provided by a spring. The adjustment is done by removing the cap and rotating the screw clockwise or counter-clockwise.

Spring load balances against the opening force of the upstream (or relief) pressure. Valve will open at the slightest increase in pressure above the spring set point, and will close when the excess pressure has been relieved.

The higher the system pressure is above the relief set point pressure, the more flow the valve will pass. It is therefore typical to specify the maximum capacity of a back pressure relief valve at 10% & 20% over set pressure.

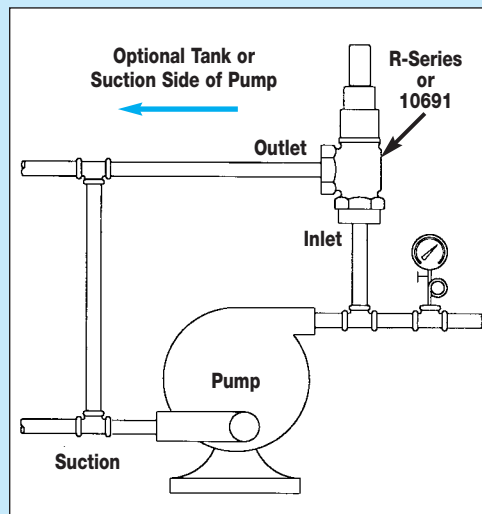

A Relief Valve allows water to recirculate through the pump even when the discharge valve on the pump is completely closed. As a rule, a minimum of 20% of the pump capacity must recirculate to prevent overheating of the pumped liquid.

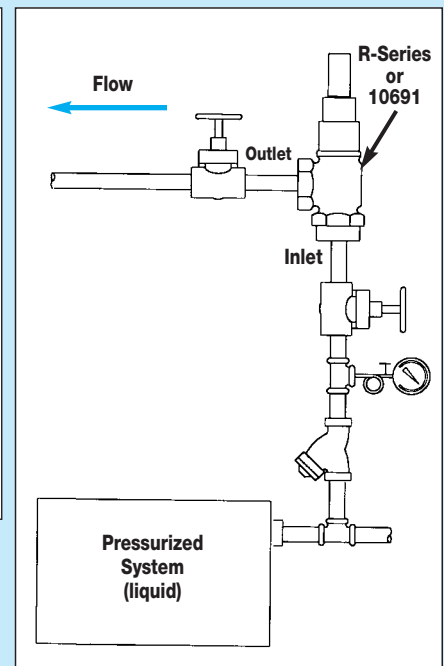

BACK PRESSURE RELIEF VALVES

3040 Series

Relief & Back Pressure Regulating Valve

Watson McDaniel reserves the right to change the designs and/or materials of its products without notice.
©2010 Watson McDaniel Company

Model	3040 Series
Service	Water, Oil, other Liquids, Air
Sizes	1/2", 3/4", 1", 1 1/4", 1 1/2", 2"
Connections	NPT, 125# & 250# Flanged
Body Material	Bronze - 1/2" - 1 1/2" Threaded Cast Iron - 2" Threaded Cast Iron - 2" Flanged
Disc Material	Buna-N/Teflon - 200°F max Viton (optional) - 300°F max
Diaphragm	Neoprene/Nylon - 200°F max Viton (optional) - 300°F max
Max. Inlet Pressure	250 PSIG



DESIGN PRESSURE/TEMPERATURE RATING – PMA/TMA

NPT	300 PSIG @ 200°F
125# FLG	125 PSIG @ 200°F
250# FLG	250 PSIG @ 200°F

TYPICAL APPLICATIONS

The **3040 Series** Back Pressure Valves relieve upstream pressure in a variety of processes. Automatically maintains desired maximum pressure in a vessel or system by relieving excess pressure into lower pressure return line or to atmosphere. Ideally suited for use as pump bypass control valve by maintaining constant pump discharge pressures. Used as a continuously operating valve for protection against overpressure conditions.

CAUTION: Not to be used as an emergency or safety relief valve.

FEATURES & OPTIONS

- Soft Seat for tight shut-off
- Easy maintenance
- Self-contained
- Fast response
- Accurate control
- Optional Viton trim for 300°F service

PRESSURE ADJUSTMENT

Rotating the adjustment screw clockwise increases the compression on the spring, thereby increasing the set pressure. Rotating the adjustment screw counter-clockwise, lowers the set pressure. Tighten lock nut after adjustment.

HOW TO SIZE/ORDER

- Specify:
- Regulator **3040 Series**
 - Size based on capacity chart
 - Spring range or relief pressure

Example: **2" 3040 Series – 5-35 PSIG spring range**

PRESSURE-ADJUSTING SPRING RANGES

Relief Pressure (PSIG)	Spring No.
1-12	4*
5-35	3
20-70	2
40-125	1

* 1/2" - 1" only

DIMENSIONS & WEIGHTS – inches/pounds

Size	Face-to-Face A			B	C	Weight (lbs)
	NPT Threaded	125# Flanged	250# Flanged			
1/2"	4 ¹ / ₈			2 ⁵ / ₁₆	9	10
3/4"	4 ¹ / ₈			2 ⁵ / ₁₆	9	10
1"	4 ¹ / ₈			2 ⁵ / ₁₆	9	10
1 1/4"	4 ¹³ / ₁₆			3 ¹ / ₄	12 ³ / ₄	15
1 1/2"	5 ³ / ₁₆			3 ¹ / ₂	13 ¹ / ₄	17
2"	9 ¹ / ₂	10 ³ / ₈	10 ⁷ / ₈	5 ¹ / ₂	16 ³ / ₄	45

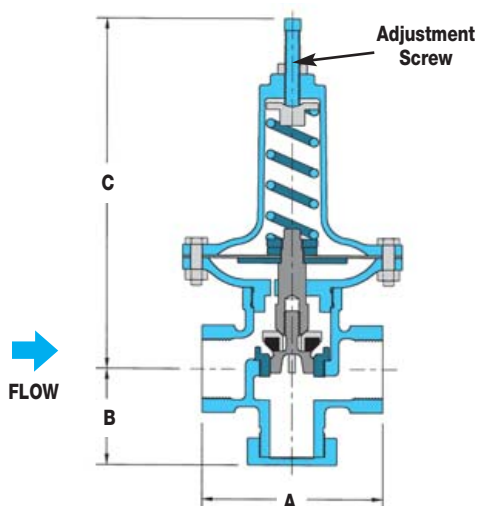

BACK PRESSURE RELIEF VALVES

3040 Series

Relief & Back Pressure Regulating Valve

CAPACITIES – Water (GPM)

		At 10% Over Set Pressure					
Spring Range (PSIG)	Set Pressure (PSIG)	1/2"	3/4"	1"	1 1/4"	1 1/2"	2"
1-12	5	4.0	8.0	10.0	–	–	–
5-35	10	5.7	11.4	14.3	29	43	71
5-35	20	8.1	16.2	20.3	41	61	101
20-70	50	12.7	25.4	31.8	64	95	159
40-125	75	15.6	31.2	39.0	78	117	195
40-125	100	18.0	36.0	45.0	90	135	225
40-125	125	20	40	50	100	150	250

		At 20% Over Set Pressure					
Spring Range (PSIG)	Set Pressure (PSIG)	1/2"	3/4"	1"	1 1/4"	1 1/2"	2"
1-12	5	4.4	8.8	11.2	–	–	–
5-35	10	6.3	12.5	16.0	32	47	79
5-35	20	8.9	17.8	22.7	45	67	113
20-70	50	14.0	27.	35.6	71	105	177
40-125	75	17.2	34.3	43.7	87	129	217
40-125	100	19.8	39.6	50.4	101	149	250
40-125	125	22	44	56	112	166	278

CAPACITIES – Air (SCFM)

		At 10% Over Set Pressure					
1/2"	3/4"	1"	1 1/4"	1 1/2"	2"		
31	55	111	–	–	–		
39	70	141	203	297	422		
56	100	201	290	424	603		
106	191	381	551	805	1144		
148	266	532	768	1123	1596		
190	341	682	986	1441	2047		
231	416	833	1203	1758	2499		

		At 20% Over Set Pressure					
1/2"	3/4"	1"	1 1/4"	1 1/2"	2"		
32	57	113	–	–	–		
41	73	146	211	308	438		
59	106	212	306	447	635		
114	204	409	591	863	1226		
159	287	573	828	1210	1719		
205	369	737	1065	1556	2212		
250	451	901	1302	1903	2704		

The 3040 Series Relief Valve water and air capacities at both 10% and 20% over "Set Pressure" are tabulated in the above tables. Enter the chart at the desired "Set Pressure" in the gray column and read the capacity in GPM or SCFM to determine proper Valve Size. Select a spring with a relief range that includes the "Set Pressure" required. Example: A 1" valve set at 50 PSIG will pass 35.6 GPM water or 409 SCFM air if the system pressure exceeds the set point by 20%.

DIRECT-OPERATED REGULATING VALVES

HOW IT WORKS

The 3040 Series Back Pressure Valve senses upstream pressure acting on the underside of the diaphragm through a port in the bottom diaphragm case.

An increase in the upstream pressure above the set point will compress the spring and allow the valve to open. The spring will close the valve as the upstream pressure decreases to the set point.

The higher the system pressurizes above the relief set point pressure, the more flow the valve will pass. It is therefore typical to specify the maximum capacity of a back pressure relief valve at 10% & 20% over set pressure.

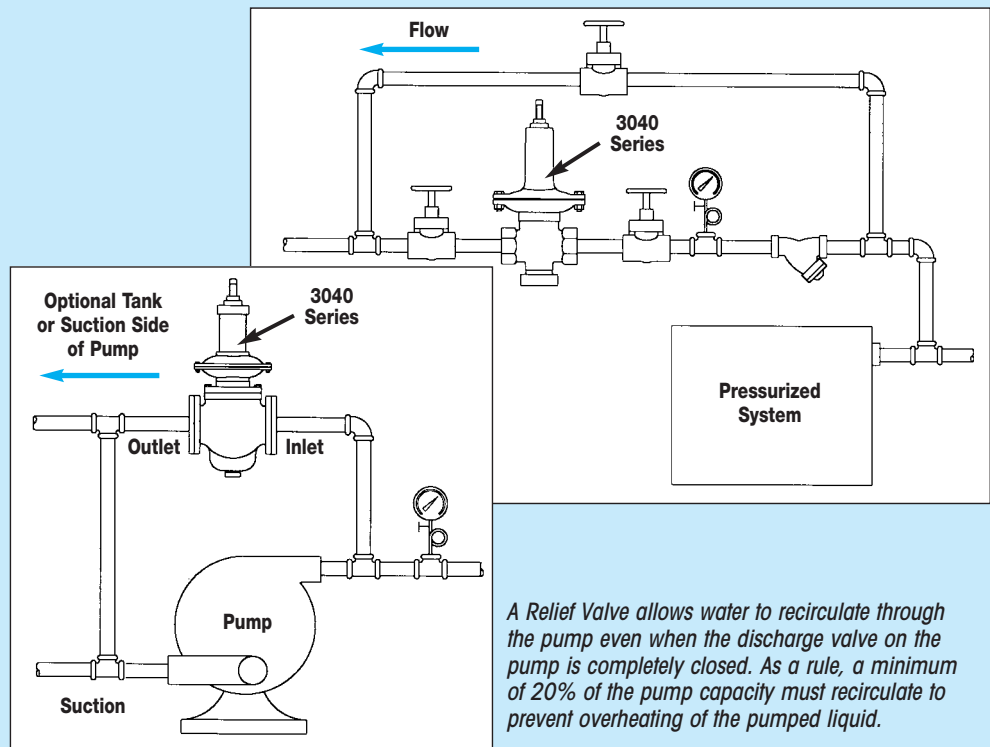

A Relief Valve allows water to recirculate through the pump even when the discharge valve on the pump is completely closed. As a rule, a minimum of 20% of the pump capacity must recirculate to prevent overheating of the pumped liquid.

TEMPERATURE REGULATORS

W91/W94 Series

Self-Operated Temperature Regulators

Watson McDaniel reserves the right to change the designs and/or materials of its products without notice.
©2010 Watson McDaniel Company

Design & Operation

W91 – Non-Indicating

W94 – Dial Thermometer

DIRECT-OPERATED
REGULATING VALVES

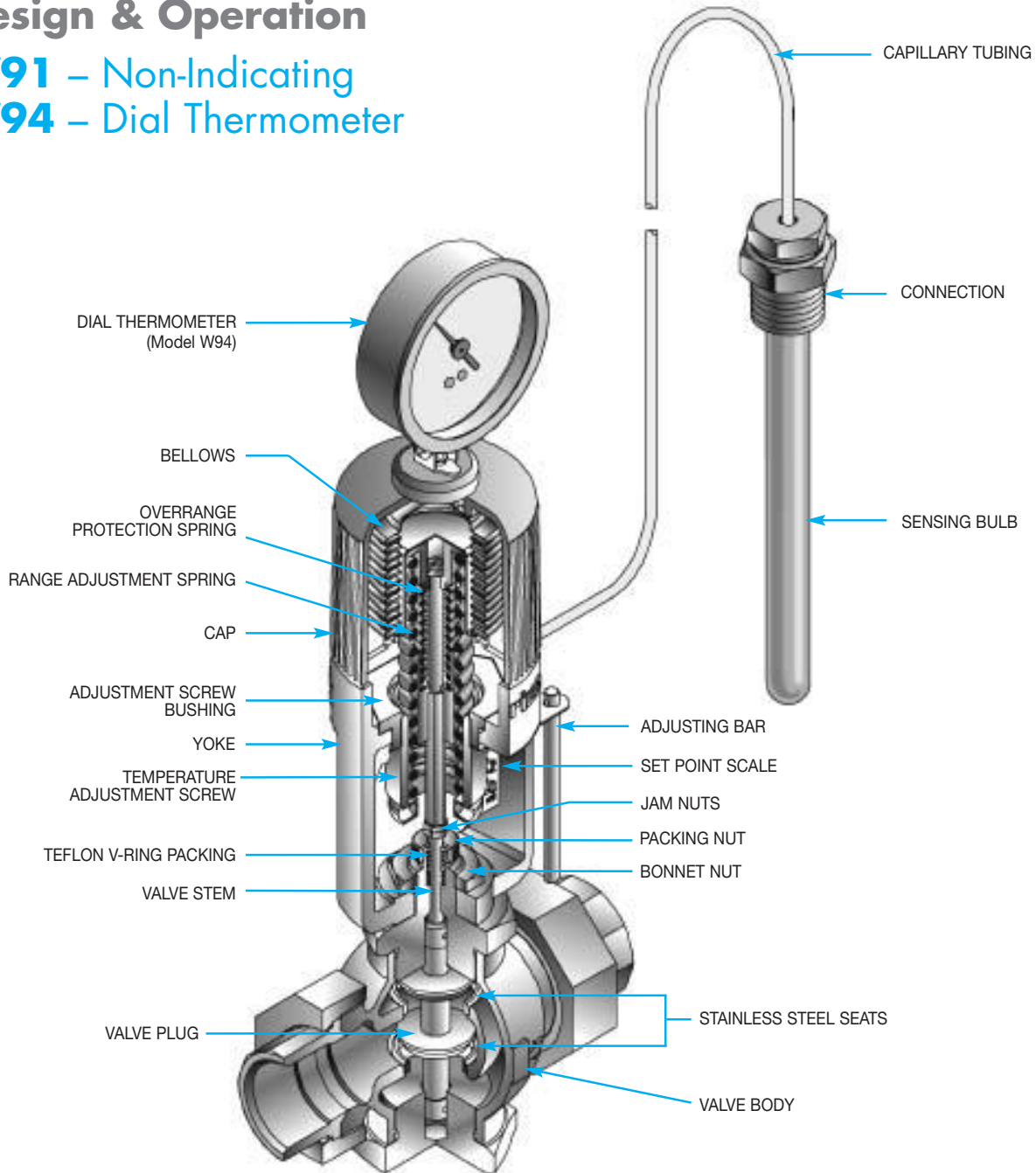

Housing Assembly

The housing consists of a cap and yoke constructed from precision die cast aluminum. This assembly ensures permanent alignment with the valve body, while protecting the bellows assembly. The yoke includes a set point scale used to reference the setting of the temperature adjustment screw. The entire housing is finished in a corrosion resistant, baked blue epoxy.

TEMPERATURE REGULATORS

W91/W94 Series Self-Operated Temperature Regulators

Design & Operation

Description

The **W91/W94** Self-Operating Temperature Regulator is a mechanically operated device designed to regulate system temperature by modulating the flow of a heating or cooling fluid in response to temperature changes.

Principles of Operation

The **W91/W94** Temperature Regulator is a fully self-contained unit, requiring no external power source (i.e., compressed air or electricity). Regulation takes place when the sensing element (bulb) of the thermal system is exposed to changes in temperature. The thermal system is charged with a predetermined amount of vapor fill, which, when heated, will cause a bellows within the unit's actuator housing to expand. As the bellows expands, it compresses a return spring while simultaneously moving the valve stem downward to stroke the valve. When the process temperature decreases (or in the event of thermal system failure), the return spring will move the valve stem upward to the "out" position. The choice of valve action (stem **In-To-Close for Heating** or stem **In-To-Open for Cooling**) will determine the system failure position.

Direct-Acting – HEATING

Direct-Acting actuators are designed to move the valve stem closed (**in-to-close**) as the control signal (temperature) increases.

Reverse-Acting – COOLING

Reverse-Acting actuators are designed to move the valve stem open (**in-to-open**) as the control signal (temperature) increases.

Selecting a Temperature Regulator

The **W91/W94** Temperature Regulator is recommended for controlling the flow on relatively stable systems, where small valve stroke modulations will correct temperature drift. Where sudden or large load changes, or rapid temperature changes occur, a pneumatically or electrically powered Control Valve should be specified. Please consult the Control Valves section of this catalog.

Actuator

The actuator consists of the following assemblies: housing, bellows and spring return, and thermal system. Two actuator models are available:

- **Model W91** is non-indicating.
- **Model W94** is equipped with an integral dial thermometer to indicate sensing bulb temperature.

TEMPERATURE REGULATORS

W91/W94 Series

Self-Operated Temperature Regulators

Watson McDaniel reserves the right to change the designs and/or materials of its products without notice.
©2010 Watson McDaniel Company

Design & Operation

Bellows & Spring Return Assembly

The accordion type bellows is corrosion resistant to provide accurate response for the life of the regulator. An adjusting bar is provided to turn the brass temperature adjustment screw, which compresses or expands the range adjustment spring, thereby setting the control point of the unit.

Thermal System Assembly

The thermal system (sensing bulb and capillary tubing) is available in copper (for best heat transfer) or 316 stainless steel (for corrosive applications) and can be ordered with a variety of protective coverings, including Teflon or stainless steel spiral armor. Capillary tubing lengths can be specified from 8 to 52 feet.

Integral Dial Thermometer

The integral dial thermometer (Model **W94**) displays the temperature at the sensing bulb. This allows for easy adjustment of the temperature set point, as well as continuous monitoring of the application, without the installation of an additional thermometer. The thermometer has a 3 1/2" dialface and can be rotated and tilted for maximum readability.

Temperature Range

Nominal ranges from 20°F (-10°C) through 440°F (225°C) are available. The nominal range defines the entire temperature range of the unit. The service conditions and choice of valve style and action will determine the actual operating range (recommended working span) of the unit. The nominal range should be selected so that the set point falls within the recommended working span for the specified valve style and action. Models **W91/W94** include an overrange protection spring, which allows the sensing bulb to be heated 100°F above the upper limit of the unit's nominal range for system cleaning or temporary situations.

Accuracy

The **W91/W94** Temperature Regulator is a "set-and-forget" regulating device. Once the proper control point setting has been achieved, the unit requires virtually no adjustments and very little maintenance. Control point accuracy is dependent upon the sensing bulb location, load change size and speed, and valve size. The sensing bulb must be installed in an area within the process that is most representative of overall process conditions. Care should be taken not to locate the bulb in close proximity to the valve, as the regulator might respond to temperature changes before the process has had time to reach the control point. Where sudden or large load changes occur, a pneumatically or electrically powered Control Valve should be specified. Please consult the Control Valves section of this catalog.

Sensing Bulb Installation:

Care must be taken to ensure that entire length of the sensing bulb is immersed into the medium at the sensing location. Partial immersion will result in faulty control. When the sensing bulb is installed into a pipeline, constant flow must be continued through the line in order to maintain an active thermal signal to the bulb. Should a closed valve cause stoppage of flow to the bulb, a reduced bypass flow must be installed to maintain the thermal signal.

The sensing bulb is designed to be installed in either a horizontal position or a vertical position with the tip down. If the tip must be installed upwards, please specify when ordering, as a special bulb construction is required.

TEMPERATURE REGULATORS

W91/W94 Series

Self-Operated Temperature Regulators

Design & Operation

Accuracy (continued)

Valve sizing also plays a major part in regulator performance. A valve that is too small will not be able to provide the desired capacity during peak load conditions, while a valve that is too large may overshoot the control point and operate with the valve plug too close to the seat, resulting in undue wear of the plug and seat. As part of a well-designed system, a properly sized valve (operating in the 60-90% open position) can control to within 2 to 5 °F.

Valve

W91/W94 Temperature Regulators are available with a wide variety of globe valves in various styles, materials, connections and sizes.

Style

W91/W94 Regulator Valves are offered in single-seated, double-seated and three-way designs:

- **Single-Seated Balanced Valves** are designed for heating applications where tighter shut-off is required. The leakage rate is approximately 0.1% of the maximum capacity.
- **Double-Seated Balanced Valves** are designed for cooling applications where a slight amount of leakage is normally acceptable. Since temperature fluctuations may cause expansion and contraction across the seats, tight shut-off is not always possible. The leakage rate can be up to approximately 0.5% of the maximum capacity.
- **3-Way Valves** are used for mixing two flows together, or for diverting a flow to or around a device (bypass). In order to produce consistent flow quantity for stable operation, the pressure drop across both flow paths (inlet to outlet) must be nearly equal.

3-Way Valves are of the Sleeve-Type (common port on the bottom). This type is most commonly used for diverting applications; however, due to its design it can also be used for mixing applications. The Sleeve-Type design is constructed with an O-ring around the sleeve. This O-ring is suitable for water or glycol type service, up to a maximum of 300°F. A higher temperature O-ring for use with other fluids, such as oil, or for temperatures up to 410°F, is available. Consult factory.

Thermowell

For applications in which the process media may be corrosive or contained under pressure, the use of a thermowell is required to prevent damage to the sensing bulb. A thermowell will also facilitate the removal of the sensing bulb and thermal system from the operating process. Thermowells are available in a variety of connection styles, materials and lengths.

CAUTION:
Temperature Regulators are not considered shut-off valves. A pressure surge may force a single seated valve plug open. The W91/W94 Temperature Regulator is a balanced equilibrium system at the set point and provides no power to tightly seat the valve plug. A separate power driven or hand actuated valve is required to ensure tight shut-off when necessary.

CAUTION:
3-Way Valves are not designed for use in steam applications.

Note: to ensure minimum response time, Heat Transfer Paste should be applied to the sensing portion of the bulb before installation.

DIRECT-OPERATED
REGULATING VALVES

TEMPERATURE REGULATORS

W91/W94 Series

Self-Operated Temperature Regulators

Watson McDaniel reserves the right to change the designs and/or materials of its products without notice.
©2010 Watson McDaniel Company

Design & Operation

Action

Single-Seated Valves are available as stem In-To-Close (Normally Open) for Heating applications. Double-Seated Valves are available as stem In-To-Open (Normally Closed) for Cooling applications. 3-Way Valves can be plumbed for either mixing or diverting service.

Temperature Regulator Valve Action		
Application	Stem Action	Normal (Fail) Position
Heating	In-To-Close	Normally Open
Cooling	In-To-Open	Normally Closed

Body & Material and Connection

W91/W94 Temperature Regulators are available with bronze and cast iron valve bodies with Union, Flanged and Threaded connections.

Trim

Valve trim is composed of the stem and plug assembly, and the seats within the ports. Single and double-seated bronze bodied valves employ a stainless steel, tapered plug for enhanced modulation. The valve plug is both top and bottom guided to ensure positive seating alignment. 3-Way valves use a stainless steel sleeve and brass seating surface to change flow direction within the body.

Packing

Valves feature a self-energizing Teflon V-Ring packing, which reduces leakage around the valve stem. V-Ring packing is spring loaded to maintain proper compression and does not require manual adjustment.

Size

The proper sizing of a regulating valve is one of the most important factors in its selection. A valve that is too small will not be able to provide the desired capacity during peak load conditions, while a valve that is too large may overshoot the control point and operate with the valve plug too close to the seat, resulting in undue wear of the plug and seat. The valve coefficient (C_v) is used to determine the maximum capacity of a valve. From this value, a valve body with the appropriate port size can be selected. Port sizes from 1/8" through 4" and connection sizes from 1/2" through 4" are available. Please consult the Valve Selection section of this catalog.

Valve Coefficient (C_v):

The rated valve coefficient is used to describe the relative flow capacity of the valve based on standard test conditions. Please refer to the Valve Selection Section for detailed information.

TEMPERATURE REGULATORS

W91/W94 Series

Self-Operated Temperature Regulators

Typical Applications for Temperature Regulators

W94 Heating Fuel Oil To Proper Temperature

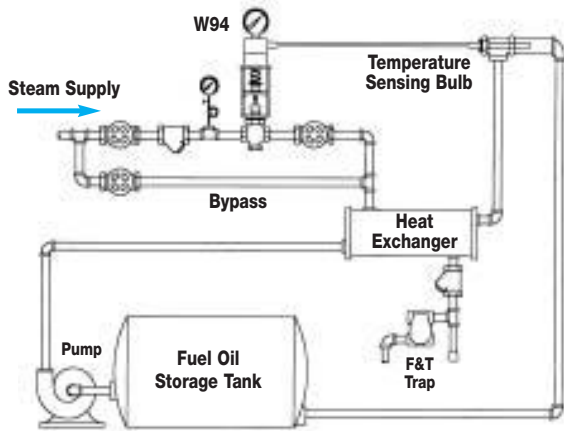

W94 Elevating Temperature Of A Plating Or Finishing Tank

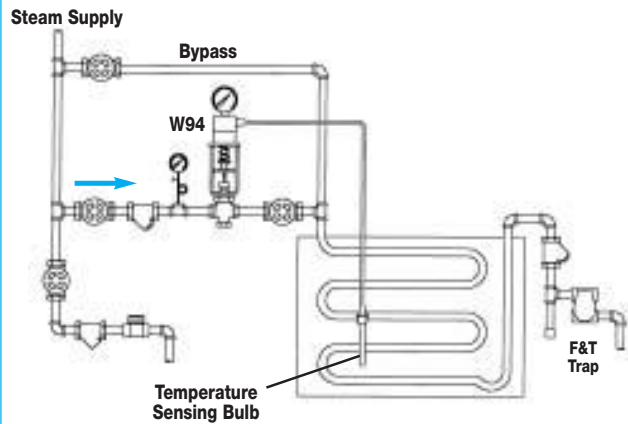

W91 Used for Regulating Steam Flow In An Autoclave/Sterilizer

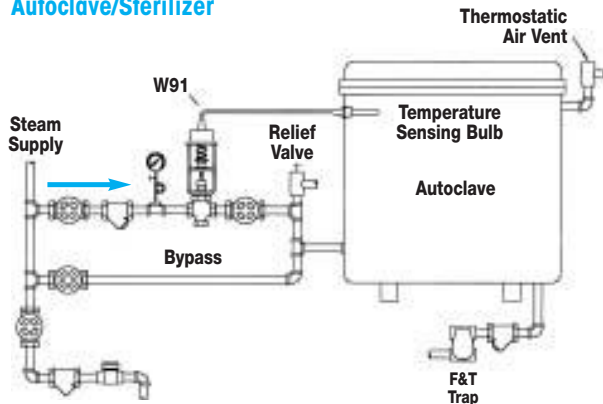

W94 Used In A Drying Oven Application

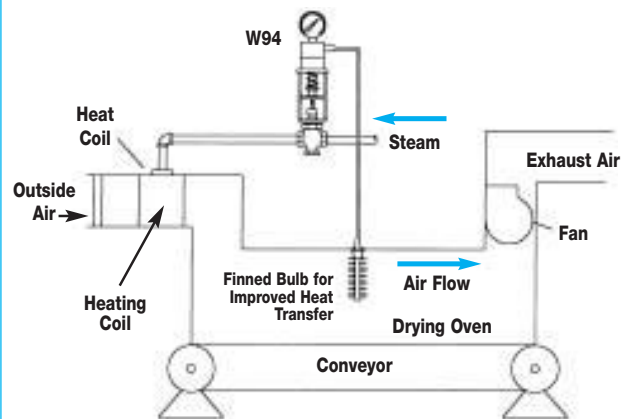

W91 Used to Reduce Oil Temperature In A Heat Exchanger

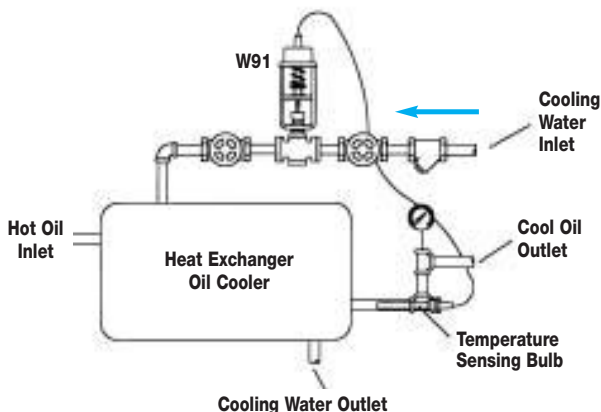

W91 Used To Control Water Flow In A Grinding Mill For Temperature Reduction

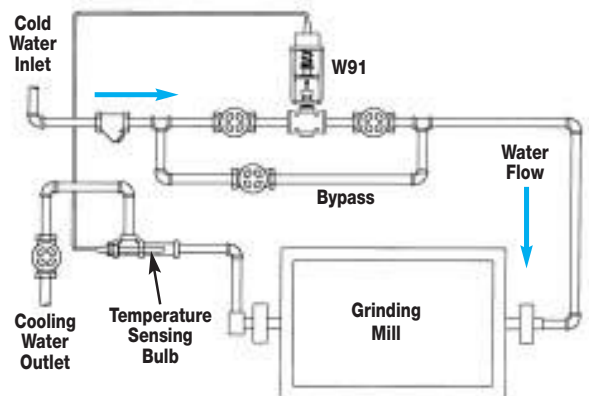

DIRECT-OPERATED REGULATING VALVES

TEMPERATURE REGULATORS

W91/W94 Series

Self-Operated Temperature Regulators

Watson McDaniel reserves the right to change the designs and/or materials of its products without notice.
©2010 Watson McDaniel Company

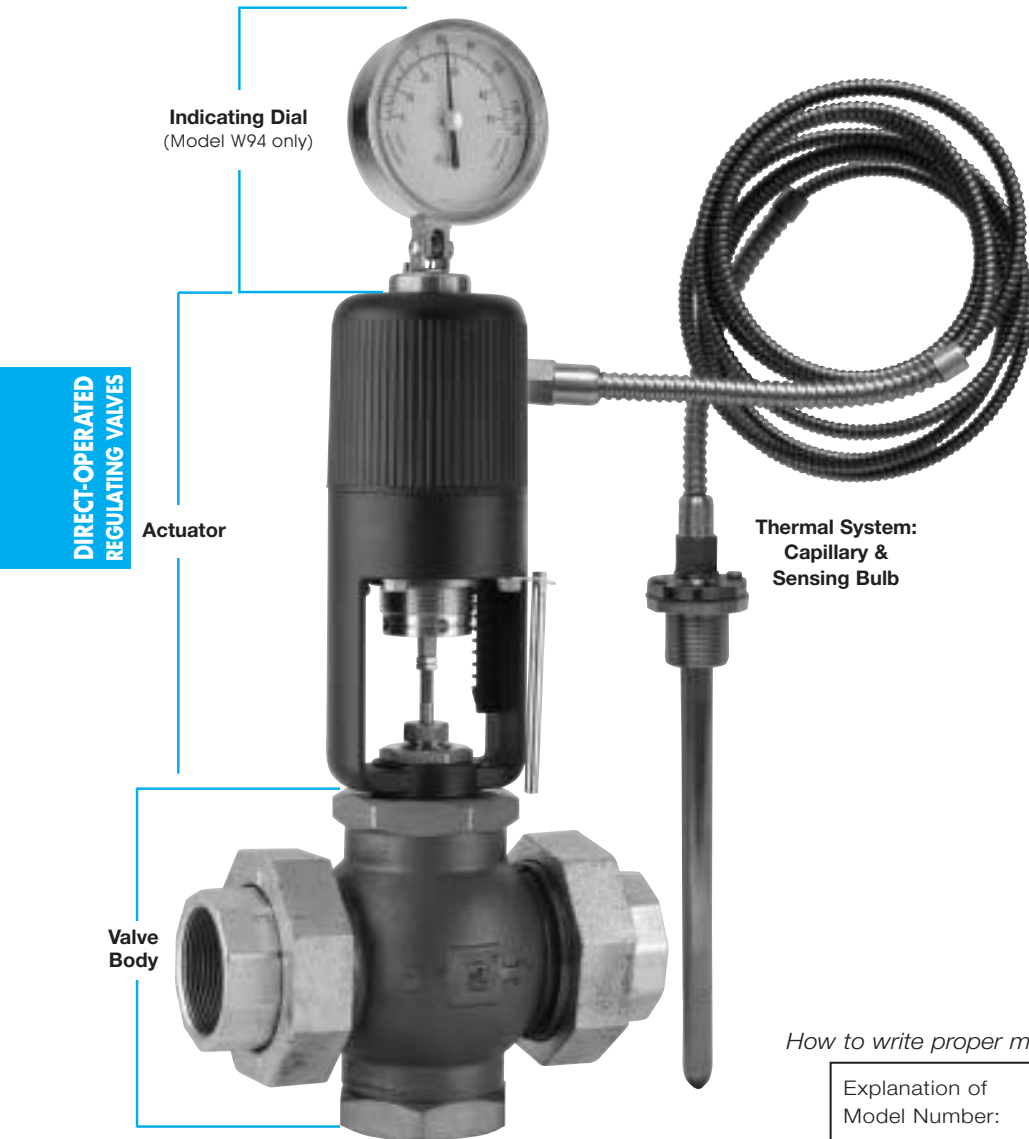

- ▶ Self-Operating Design
- ▶ Indicating & Non-Indicating Models Available
- ▶ Heavy Duty Die Cast Aluminum Housing
- ▶ 1/2" thru 4" Valve Sizes
- ▶ Fully Enclosed Bellows
- ▶ Internal Overrange protection

The **W91 & W94** Self-Operating Temperature Regulators are the preferred choice of original equipment manufacturers, mechanical contractors and specifying engineers. These regulators require no external power source and are ideal for regulating the temperature of tanks, process streams and various types of industrial equipment. The Actuator is noted for its rugged die-cast aluminum housing, fully enclosed bellows assembly and internal overrange protection.

- ▶ Model **W91** (without indicating dial) features a lower profile and should be specified where space constraints may be an issue.
- ▶ Model **W94** (with indicating dial) will allow the operator to verify the process temperature and to aid in temperature adjustment.

Thermowells:

For applications in which the process media may be corrosive or contained under pressure, the use of a thermowell is required to prevent damage to the sensing bulb. A thermowell will also facilitate the removal of the sensing bulb and thermal system from the operating process.

How to write proper model number:

Explanation of Model Number:	W91	06	08	S15	175-13
	model	temp. range	cap. length	bulb type	valve body
Model Number:	W910608S15175-13				

HOW TO ORDER

Models	Temperature Range	Capillary Length	Bulb	Valve Body Selection
W91 Non-Indicating	01 - 14	08 8 Feet (std)	S15 (brass bulb) (standard)	Refer to Valve Body Section
W94 Indicating Dial	Refer to Temperature Range Chart	12 12 Feet 16 16 Feet 20 20 Feet 24 24 Feet	S16 (stainless bulb)	(Omit this selection if purchasing Actuator only)

Note: Thermowells are ordered separately.
See page 175 for model numbers & lengths.

TEMPERATURE REGULATORS

W91/W94 Series

Self-Operated Temperature Regulators

Model	W91/W94
Service	Water, Steam, Other Liquids
Sizes	1/2" – 4"
Connections	Threaded, Union Ends, 125# FLG 250# FLG (optional)
Body Material	1/2" – 1 1/2" Bronze/Stainless Steel 2" Cast Iron (Direct-acting) 2" Bronze (Reverse-acting) 2 1/2" – 4" Cast Iron
Seat Material	Stainless Steel
Max. Inlet Pressure	250 PSIG

W91

Non-Indicating Actuator

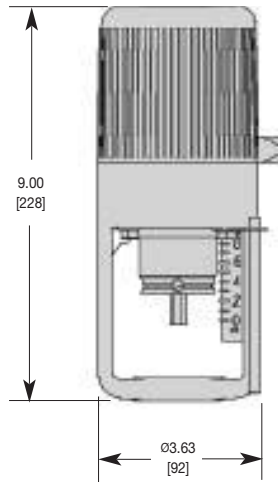

W94

Indicating Actuator

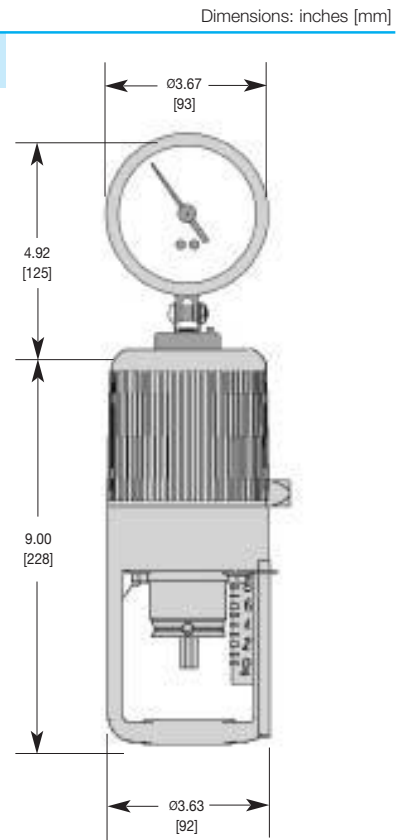

DIRECT-OPERATED
REGULATING VALVES

Specifications

Actuator Models

W91 - Non-Indicating
W94 - Indicating Dial

Dial Thermometer

3 1/2" dial, stainless steel case, swivel and angle adjustment (Model W94 only)

Housing

Die cast aluminum, epoxy powder coated blue finish

Bellows

High pressure brass, corrosion resistant, tin plated finish

Overrange Protection

Upper range limit +100°F for temporary situations

Approximate Shipping Weight

Actuator

W91 6.0 lbs [2.7 kg]
W94 6.6 lbs [3.0 kg]

Valve

See Valve Selection tables

TEMPERATURE REGULATORS

W91/W94 Series

Self-Operated Temperature Regulators

Watson McDaniel reserves the right to change the designs and/or materials of its products without notice.
©2010 Watson McDaniel Company

Temperature Range Chart

W91 & W94 Actuators				
Range Code	Nominal Range		Recommended Working Span *	
	01	20 to 70 °F	-10 to 20 °C	40 to 65 °F
02*	40 to 90 °F	5 to 30 °C	65 to 85 °F	20 to 30 °C
03	30 to 115 °F	0 to 45 °C	85 to 110 °F	30 to 45 °C
04	50 to 140 °F	10 to 60 °C	110 to 135 °F	45 to 60 °C
05	75 to 165 °F	25 to 70 °C	135 to 160 °F	60 to 70 °C
06	105 to 195 °F	40 to 90 °C	160 to 190 °F	70 to 90 °C
07	125 to 215 °F	55 to 100 °C	190 to 210 °F	90 to 100 °C
09	155 to 250 °F	70 to 120 °C	210 to 245 °F	100 to 120 °C
10	200 to 280 °F	95 to 135 °C	245 to 275 °F	120 to 135 °C
11	225 to 315 °F	110 to 155 °C	275 to 310 °F	135 to 155 °C
12	255 to 370 °F	125 to 185 °C	305 to 365 °F	155 to 185 °C
13	295 to 420 °F	145 to 215 °C	365 to 415 °F	185 to 215 °C
14	310 to 440 °F	155 to 225 °C	415 to 435 °F	215 to 225 °C

* The recommended working span typically falls within the upper third of the nominal range.

Bulb & Capillary Style

ORDER CODE	Connection Style & Material	Bulb Material	Capillary Tubing Material	Capillary Length in Ft.			
				8, 12, 16	20	24	
S15	Brass Union Hub	Copper	Copper with Stainless Steel Spiral Armor	A	13"	16"	20"
				U	12.25"	15.25"	19.25"
S16	Stainless Steel Union Hub	Stainless Steel	Stainless Steel with Stainless Steel Spiral Armor	A	13"	16"	20"
				U	12.25"	15.25"	19.25"

Other Options available. Consult Factory.

Bulb Installation: (refer to diagram below)

The 1" NPT Union Hub is not physically attached to the bulb. The 1" NPT Union Hub is threaded into a tank or vessel. The bulb slides thru the 1" NPT Union Hub and is held in place and sealed with the Union Nut, which freely turns on the stainless steel armor protected capillary. When using a Thermowell, the 1" NPT Union Hub is discarded and the Union Nut threads into the Thermowell.

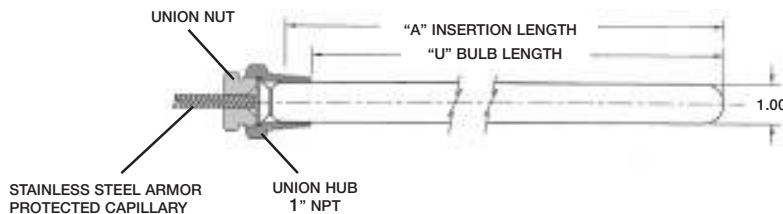

DIRECT-OPERATED REGULATING VALVES

TEMPERATURE REGULATORS

W91/W94 Series

Self-Operated Temperature Regulators

Thermowell Selection

Dimensions (inches)

BULB

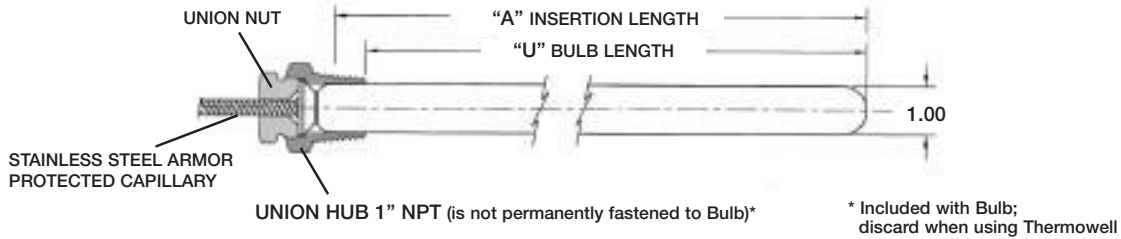

THERMOWELL

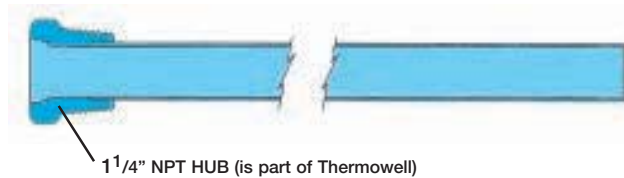

Note: to ensure minimum response time, Heat Transfer Paste should be applied to the sensing portion of the bulb before installation.

BULB inside THERMOWELL

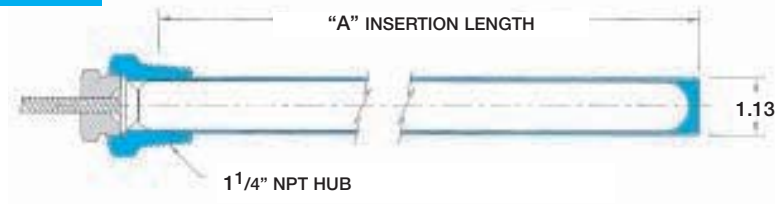

For applications in which the process media may be corrosive or contained under pressure, the use of a thermowell is required to prevent damage to the sensing bulb. A thermowell will also facilitate the removal of the sensing bulb and thermal system from the operating process. Because the sensing bulb is isolated from the fluid, this allows the sensing bulb to be removed without having to drain the liquid below the bulb insertion point.

THERMOWELLS - Model Numbers & Lengths

Brass Model No.	Stainless Steel Model No.	Nominal Length	"A" INSERTION LENGTH (in.)		Capillary Length in Feet
			BULB	THERMOWELL	
536-S2	536-S6	13"	12.25	13.00	8, 12 or 16
536-SE2	536-SE6	16"	15.25	16.00	20
536-WE2	536-WE6	20"	19.25	20.00	24

- Notes:
- 1) Other connections and lengths may be available, consult factory.
 - 2) External pressure rating on Brass is 500 PSI max.
 - 3) External pressure rating on 316 SS is 1000 PSI max.

TEMPERATURE REGULATORS

W91/W94 Series

Single Seated Valve Bodies

HEATING

Single Seat • 1/2" – 4"

Dimensions in inches

Stem In-To-Close for Heating

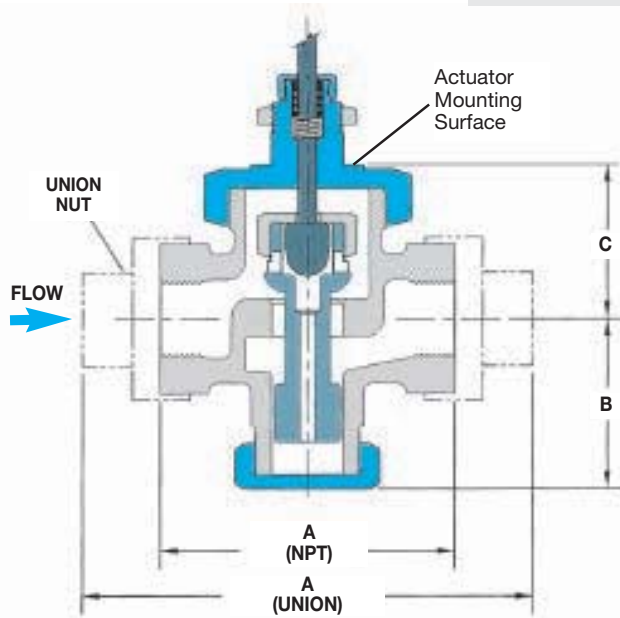

THREADED & UNION

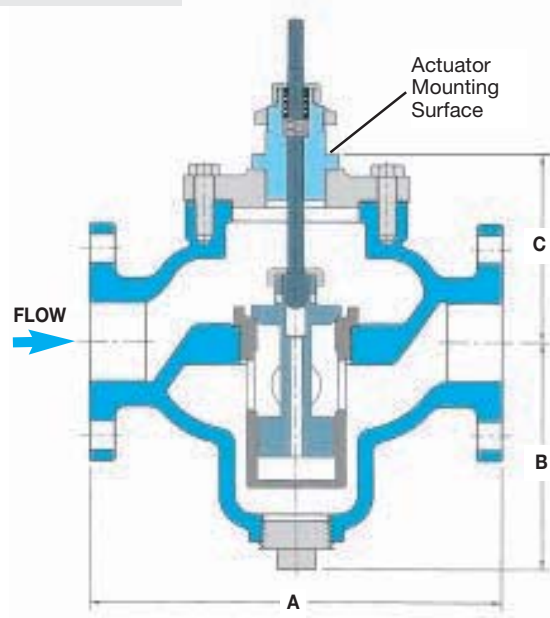

FLANGED

DIRECT-OPERATED
REGULATING VALVES

Specifications

Body Material	Trim Material	Connection	Pressure & Temperature Rating
1/2" - 1 1/2" Bronze/Stainless	Stainless Steel	Threaded or Malleable Iron Union Ends	125 PSI @ 450°F
2" Cast Iron	Stainless Steel	Threaded	250 PSI @ 450°F
2" - 4" Cast Iron	Stainless Steel	125# Flanged	125 PSI @ 450°F
		250# Flanged	250 PSI @ 450°F

Valve Body Selection

Valve Body Number (In-To-Close Heating)		Size Connection	Capacity Cv	Maximum Close-Off Pressure (PSI ΔP)		Dimensions						Approx. Ship. Wt. (lbs) [kg]
NPT	Union					A Threaded	A 125# FLG	A 250# FLG	A Union	B	C	
175-12-N	175-12-U	1/2"	3.2	250		4.125	x	x	6.50	2.375	2.12	14 [6.35]
175-13-N	175-13-U	3/4"	6.3	250		4.125	x	x	6.50	2.375	2.12	14 [6.35]
175-14-N	175-14-U	1"	10.8	200		4.125	x	x	7.00	2.375	2.12	14 [6.35]
175-15-N	175-15-U	1 1/4"	15.9	200		4.81	x	x	7.50	3.25	2.50	17 [7.7]
175-16-N	175-16-U	1 1/2"	22.4	200		5.19	x	x	8.00	3.50	2.69	18 [8.2]
175-17-N		2"	33.1	150		9.50	x	x	x	5.75	4.75	50 [22.7]
FLANGED				Valve Type								
125#	250#			Standard	Special							
175-17-125	175-17-250	2"	33.1	150	-	x	10.375	10.875	x	5.75	4.75	80 [36.3]
175-18-125	175-18-250	2 1/2"	47.5	65	150	x	10.625	11.25	x	7.00	5.00	96 [43.6]
175-19-125	175-19-250	3"	68.2	50	150	x	10.875	11.625	x	8.00	5.75	110 [49.9]
175-20-125	175-20-250	4"	109.5	40	150	x	10.50	13.125	x	8.75	6.50	160 [72.6]

Note: For 2 1/2" - 4" sizes, consult factory for proper actuators.

TEMPERATURE REGULATORS

W91/W94 Series

Capacity Chart for Single Seated Valves

Watson McDaniel reserves the right to change the designs and/or materials of its products without notice.
©2010 Watson McDaniel Company

CAPACITIES – Steam (lbs/hr)		SINGLE SEATED VALVES							
Inlet Pressure (PSIG)	Size & Valve Body Number								
	1/2"	3/4"	1"	1 1/4"	1 1/2"	2"	2 1/2"	3"	4"
	175-12	175-13	175-14	175-15	175-16	175-17	175-18	175-19	175-20
1	91	180	309	454	640	946	1357	1949	3129
3	103	203	348	512	722	1066	1530	2197	3527
5	115	226	387	570	803	1187	1703	2445	3926
10	144	283	486	715	1007	1488	2135	3066	4922
15	173	341	584	859	1211	1789	2568	3686	5919
20	202	398	682	1004	1415	2090	3000	4307	6915
25	231	455	780	1149	1618	2392	3432	4928	7912
30	260	513	879	1294	1822	2693	3864	5548	8908
40	319	627	1075	1583	2230	3295	4729	6790	10,901
50	377	742	1272	1872	2638	3898	5593	8031	12,894
60	435	857	1468	2162	3045	4500	6458	9272	14,887
70	493	971	1665	2451	3453	5102	7322	10,513	16,880
80	552	1086	1861	2740	3861	5705	8187	11,755	18,873
90	610	1200	2058	3030	4268	6307	9051	12,996	20,866
100	668	1315	2255	3319	4676	6910	9916	14,237	22,859
125	814	1602	2746	4043	5695	8416	12,077	17,340	27,841
150	959	1888	3237	4766	6714	9922	14,238	20,443	32,823
175	1105	2175	3729	5490	7734				
200	1250	2462	4220	6213	8753				
250	1542	3035							

Note: Verify that Maximum Close-Off Pressure for 2" - 4" models does not exceed max rating for selected Valve Body Number and Type. (Refer to Valve Body Number chart on previous page)

DIRECT-OPERATED REGULATING VALVES

Notes: 1) For reduced-port 1/2" valves, consult factory. 2) All steam capacities based on Critical Drop (Choked Flow).

CAPACITIES – Water (GPM)		SINGLE SEATED VALVES							
Pressure (PSI ΔP)	Size & Valve Body Number								
	1/2"	3/4"	1"	1 1/4"	1 1/2"	2"	2 1/2"	3"	4"
	175W-12	175W-13	175W-14	175W-15	175W-16	175W-17	175W-18	175W-19	175W-20
1	3.2	6.3	11	16	22	33	48	68	110
3	5.5	11	19	28	39	57	82	118	190
5	7.2	14	24	36	50	74	106	152	245
10	10	20	34	50	71	105	150	216	346
15	12	24	42	62	87	128	184	264	424
20	14	28	48	71	100	148	212	305	490
25	16	32	54	80	112	166	238	341	548
30	18	35	59	87	123	181	260	374	600
40	20	40	68	101	142	209	300	431	693
50	23	45	76	112	158	234	336	482	774
60	25	49	84	123	174	256	368	528	848
70	27	53	90	133	187	277	397	571	916
80	29	56	97	142	200	296	425	610	979
90	30	60	102	151	213	314	451	647	1039
100	32	63	108	159	224	331	475	682	1095
125	36	70	121	178	250	370	531	762	1224
150	39	77	132	195	274	405	582	835	1341
175	42	83	143	210	296				
200	45	89	153	225	317				
250	51	100							

Note: When 175 Type Single Seated Valves are used with water, add **W** to the Valve Body Number.

Example:
175-17-N becomes 175W-17-N

Note: Verify that Maximum Close-Off Pressure for 2" - 4" models does not exceed max rating for selected Valve Body Number and Type. (Refer to Valve Body Number chart on previous page)

TEMPERATURE REGULATORS

W91/W94 Series

Watson McDaniel reserves the right to change the designs and/or materials of its products without notice.
©2010 Watson McDaniel Company

Steam Required for Heating Water

Steam flow required through a temperature regulator (lbs/hr) to heat a specified number of gallons of water per hour (gal/hr)

TABLE 1 - Steam Flow Required in Pounds Per Hour (lbs/hr)

Temp Increase (°F)	Gallons of Water per Hour To Be Heated												Temp Increase (°F)
	25	50	100	200	300	500	700	1000	2000	4000	10,000	20,000	
5°	1	2	4	8	12	21	29	41	83	166	415	830	5°
10°	2	4	8	16	25	41	58	83	166	332	830	1660	10°
15°	3	6	12	25	37	62	87	124	249	498	1245	2490	15°
20°	4	8	17	33	50	83	116	166	332	664	1660	3320	20°
25°	5	10	20	42	62	104	145	207	415	830	2075	4150	25°
30°	6	12	25	50	75	124	174	249	498	996	2490	4980	30°
40°	8	16	33	66	100	166	232	332	664	1328	3320	6640	40°
50°	10	21	42	83	124	207	290	415	830	1660	4150	8300	50°
60°	12	25	50	100	149	249	348	498	996	1992	4980	9960	60°
70°	15	29	58	116	174	290	407	581	1162	2324	5810	11,620	70°
80°	17	33	67	133	199	332	465	664	1328	2656	6640	13,280	80°
90°	19	38	75	149	224	373	523	747	1494	2988	7470	14,940	90°
100°	21	42	83	166	249	415	581	830	1660	3320	8300	16,600	100°
115°	24	48	95	191	286	477	668	955	1909	3818	9544	19,088	115°
130°	27	54	108	216	324	539	755	1079	2158	4316	10,790	21,580	130°
145°	30	60	120	241	361	601	842	1200	2400	4812	12,030	24,060	145°
160°	33	66	133	266	398	664	929	1328	2656	5312	13,280	26,560	160°
175°	36	72	145	290	436	726	1017	1452	2900	5810	14,524	29,048	175°
200°	41	83	166	332	498	830	1162	1660	3320	6640	16,600	33,200	200°
225°	47	94	187	374	560	934	1307	1867	3735	7470	18,680	37,360	225°
250°	52	104	207	415	622	1037	1452	2075	4150	8300	20,750	41,500	250°

DIRECT-OPERATED REGULATING VALVES

HEATING WATER: The amount of steam required to heat water can be found using chart above.

Example: To heat 1000 gallons per hour of water from 40°F to 140°F (Temp. increase 100°F) requires 830 lbs/hr of steam.

HEATING FUEL OIL: The amount of steam required to heat fuel oil is half of that to heat water. Use half the value found in chart above.

Example: To heat 1000 gallons per hour of fuel oil from 40°F to 140°F (Temp. increase 100°F) requires 415 lbs/hr of steam.

CAPACITY FORMULAS FOR STEAM LOADS

When BTU Load is Known	Capacity of steam required (lbs/hr)	= $\frac{\text{BTU}}{1000}$
When Square Feet Equivalent Direct Radiation (EDR) is Known	Capacity of steam required (lbs/hr)	= $\frac{\text{Sq. ft. of EDR}}{4}$
When Heating Water with Steam	Capacity of steam required (lbs/hr)	= $\frac{\text{GPM} \times \text{Temp Rise } ^\circ\text{F}}{2}$
When Heating Fuel Oil with Steam	Capacity of steam required (lbs/hr)	= $\frac{\text{GPM} \times \text{Temp Rise } ^\circ\text{F}}{4}$
When Heating Air with Steam Coils	Capacity of steam required (lbs/hr)	= $\frac{\text{CFM} \times \text{Temp Rise } ^\circ\text{F}}{900}$

TEMPERATURE REGULATORS

W91/W94 Series

Double Seated Valve Bodies

COOLING

Dimensions in inches [mm]

Double Seat • 3/4" – 4"

Stem In-To-Open
for Cooling

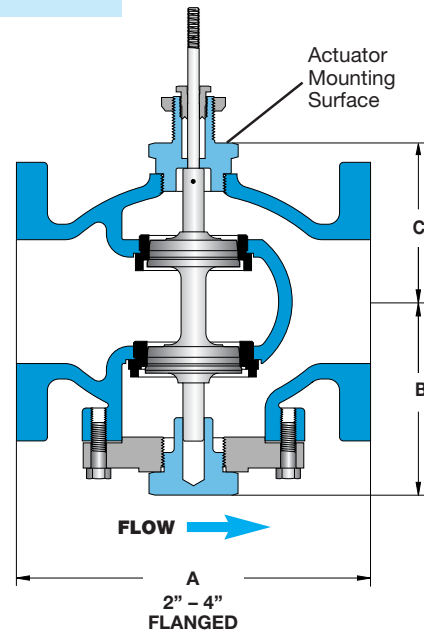
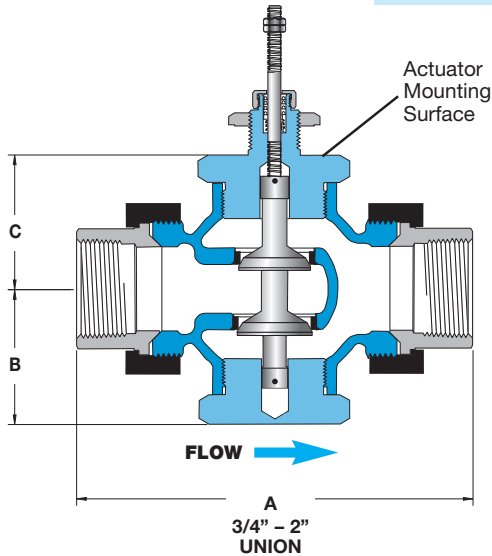

DIRECT-OPERATED
REGULATING VALVES

Specifications

Body Material	Trim Material	Trim Style Connection	Pressure & Temperature Rating
3/4" - 2" Bronze	Stainless Steel	Threaded with Malleable Iron Union Ends	250 PSI @ 410°F (210°C)
2 1/2" - 4" Cast Iron	Stainless Steel	125# Flanged	125 PSI @ 350°F (149°C)

Valve Body Selection – Threaded

Valve Body Number (In-To-Open Cooling)	Size		Capacity C _v	Maximum Close-Off Pressure (PSI ΔP)	Dimensions			Approximate Shipping Wt. (lbs) [kg]
	Connection (NPT)	Nominal Port			A	B	C	
A24	3/4	3/4"	8	250	5.6 [142]	2.3 [58]	2.3 [58]	5.0 lbs [2.25 kg]
A33	1	1"	12	250	6.0 [152]	2.3 [58]	2.3 [58]	6.1 lbs [2.75 kg]
A44	1 1/4	1 1/4"	21	250	7.2 [183]	2.6 [66]	2.6 [66]	10.1 lbs [4.55 kg]
A55	1 1/2	1 1/2"	30	250	7.7 [196]	2.6 [66]	2.6 [66]	11.1 lbs [5.00 kg]
A66	2	2"	47	250	8.6 [218]	3.1 [79]	3.1 [79]	17.0 lbs [7.65 kg]

Valve Body Selection – Flanged

Valve Body Number (In-To-Open Cooling)	Size		Capacity C _v	Maximum Close-Off Pressure (PSI ΔP)	Dimensions			Approximate Shipping Wt. (lbs) [kg]
	Connection	Nominal Port			A	B	C	
B74	2 1/2"	2 1/2"	69	65	7.8 [198]	4.8 [122]	5.4 [137]	45 lbs [20 kg]
B79	3"	3"	90	50	9.0 [229]	5.0 [127]	5.6 [142]	70 lbs [32 kg]
B84	4"	4"	196	40	11.4 [290]	6.3 [160]	6.5 [165]	100 lbs [45 kg]

TEMPERATURE REGULATORS

W91/W94 Series

Capacity Chart for Double Seated Valves

Watson McDaniel reserves the right to change the designs and/or materials of its products without notice.
©2010 Watson McDaniel Company

COOLING

CAPACITIES – Water (GPM)		DOUBLE SEATED VALVES						
Pressure Drop (PSI ΔP)	Size, Valve Body Number & Coefficient (Cv)							
	3/4"	1"	1 1/4"	1 1/2"	2"	2 1/2"	3"	4"
	A24 ITO Cv = 8	A33 ITO Cv = 12	A44 ITO Cv = 21	A55 ITO Cv = 30	A66 ITO Cv = 47	B74 ITO Cv = 69	B79 ITO Cv = 90	B84 ITO Cv = 196
1	8	12	21	30	47	69	90	196
3	14	21	36	52	81	120	156	339
5	18	27	47	67	105	154	201	438
10	25	38	66	95	149	218	285	620
15	31	46	81	116	182	267	349	759
20	36	54	94	134	210	309	402	877
25	40	60	105	150	235	345	450	980
30	44	66	115	164	257	378	493	1074
40	51	76	133	190	297	436	569	1240
50	57	85	148	212	332	488	636	
60	62	93	163	232	364			
70	67	100	176	251	393			
80	72	107	188	268	420			
90	76	114	199	285	446			
100	80	120	210	300	470			
125	89	134	235	335	525			
150	98	147	257	367	576			
175	106	159	278	397	622			
200	113	170	297	424	665			
225	120	180	315	450	705			
250	126	190	332	474	743			

ITO = In-to-Open

DIRECT-OPERATED
REGULATING VALVES

TEMPERATURE REGULATORS

W91/W94 Series

BRONZE

3-Way Valve Bodies

Dimensions in inches [mm]

3-Way • 1/2" – 2"

for Mixing or Diverting

MIXING FLOW DIAGRAM

DIVERTING FLOW DIAGRAM

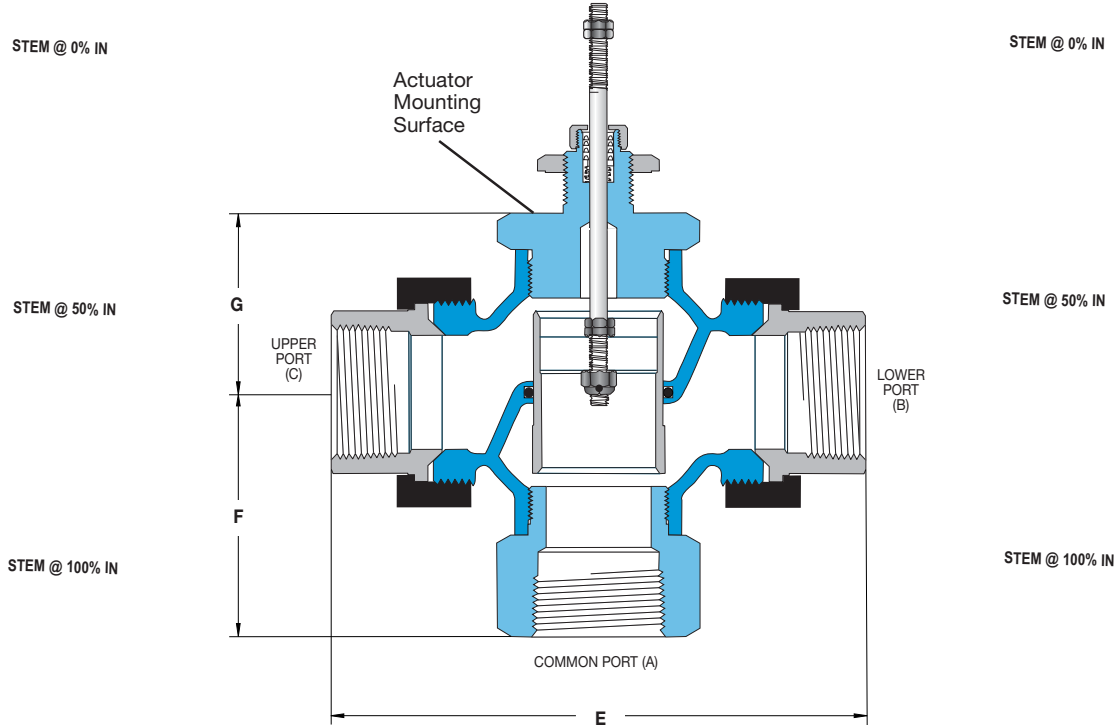

DIRECT-OPERATED
REGULATING VALVES

CAUTION: 3-Way Valves are not designed for use in steam applications. To properly control the mixing of two flows, inlet pressures at ports B and C should be as equal as possible.

Specifications

Body Material	Trim Material	Connection	Pressure & Temperature Rating
Bronze	Bronze	Threaded with Malleable Iron Union Ends	250 PSI @ 300°F (149°C)

Valve Body Selection

Valve Body Number	Size		Capacity C _v	Maximum Close-Off Pressure (PSI ΔP)	Dimensions			Approximate Shipping Wt.
	Connection (NPT)	Nominal Port			E	F	G	
A18	1/2"	1/2"	2.8	250	4.8 [122]	1.8 [46]	1.8 [46]	2.9 lbs [1.31 kg]
A25	3/4"	3/4"	5.6	250	5.6 [142]	2.3 [58]	2.3 [58]	4.7 lbs [2.12 kg]
A34	1"	1"	8.4	250	6.0 [152]	2.3 [58]	2.3 [58]	5.7 lbs [2.57 kg]
A45	1 1/4"	1 1/4"	15	250	7.2 [183]	2.8 [71]	2.6 [66]	9.5 lbs [4.28 kg]
A56	1 1/2"	1 1/2"	21	250	7.7 [196]	3.5 [89]	2.6 [66]	11.1 lbs [5.00 kg]
A67	2"	2"	33	250	8.6 [218]	4.1 [104]	3.1 [79]	16.7 lbs [7.55 kg]

TEMPERATURE REGULATORS

W91/W94 Series

3-Way Valve Bodies

CAST IRON

3-Way • 2 1/2" – 4"

Dimensions in inches [mm]

for Mixing or Diverting

MIXING FLOW DIAGRAM

DIVERTING FLOW DIAGRAM

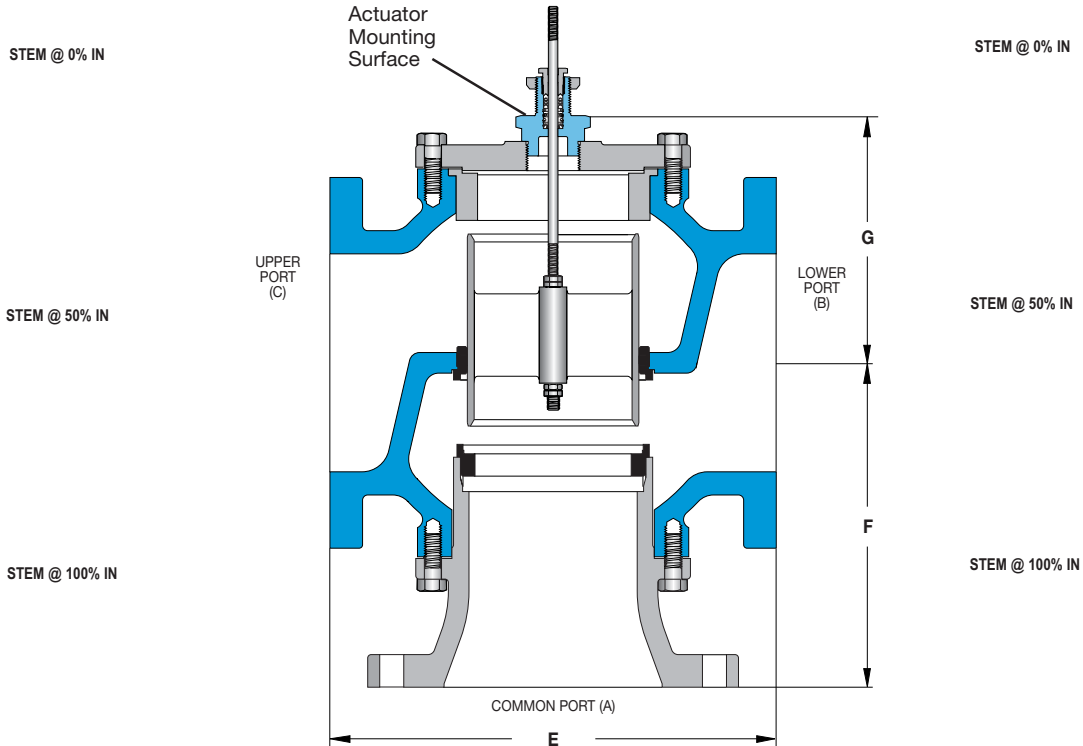

DIRECT-OPERATED
REGULATING VALVES

CAUTION: 3-Way Valves are not designed for use in steam applications. To properly control the mixing of two flows, inlet pressures at ports B and C should be as equal as possible.

Specifications

Body Material	Trim Material	Connection	Pressure & Temperature Rating
Cast Iron	Bronze	125# Flanged	125 PSI @ 300°F (149°C)

Valve Body Selection

Valve Body Number	Size		Capacity C _v	Maximum Close-Off Pressure (PSI ΔP)	Dimensions			Approximate Shipping Wt.
	Connection	Nominal Port			E	F	G	
B75	2 1/2"	2 1/2"	58	125	9.0 [229]	7.1 [180]	5.2 [132]	62 lbs [28 kg]
B80	3"	3"	72	125	10.0 [254]	8.0 [203]	6.0 [152]	80 lbs [36 kg]
B85	4"	4"	102	125	13.0 [330]	10.0 [254]	6.9 [175]	140 lbs [64 kg]

TEMPERATURE REGULATORS

W91/W94 Series

Capacity Chart for 3-Way Valves

CAPACITIES – Water (GPM)		3-WAY VALVES							
Pressure Drop (PSI ΔP)	Size, Valve Body Number & Coefficient (Cv)								
	1/2"	3/4"	1"	1 1/4"	1 1/2"	2"	2 1/2"	3"	4"
	A18 Cv = 2.8	A25 Cv = 5.6	A34 Cv = 8.4	A45 Cv = 15	A56 Cv = 21	A67 Cv = 33	B75 Cv = 58	B80 Cv = 72	B85 Cv = 102
1	2.8	5.6	8.4	15	21	33	58	72	102
3	4.8	10	15	26	36	57	100	125	177
5	6.3	13	19	34	47	74	130	161	228
10	8.9	18	27	47	66	104	183	228	323
15	11	22	33	58	81	128	225	279	395
20	13	25	38	67	94	148	259	322	456
25	14	28	42	75	105	165	290	360	510
30	15	31	46	82	115	181	318	394	559
40	18	35	53	95	133	209	367	455	645
50	20	40	59	106	148	233	410	509	721
60	22	43	65	116	163	256	449	558	790
70	23	47	70	125	176	276	485	602	853
80	25	50	75	134	188	295	519	644	912
90	27	53	80	142	199	313	550	683	968
100	28	56	84	150	210	330	580	720	1020
125	31	63	94	168	235	369	648	805	1140
150	34	69	103	184	257	404			
175	37	74	111	198	278	437			
200	40	79	119	212	297	467			
225	42	84	126	225	315	495			
250	44	89	133	237	332	522			

Note: Oil service or high temperature service requires special O-ring.

DIRECT-OPERATED
REGULATING VALVES

Control Valves

CONTROL
VALVES



W910 COMPACT
CONTROL VALVE

Control Valves



TA901
I/P TRANSDUCER



ELECTRONIC
TEMPERATURE
SENSOR
RTD or THERMOCOUPLE



TR890
ELECTRONIC
PID CONTROLLER



TA987
AIR FILTER/REGULATOR

CONTROL
VALVES

Control Valves

Page No.

W910 Series Compact Control Valve

186-196

The **W910 Series Pneumatic Control Valve** offers high quality at an economical price, incorporating many features found only on more expensive units. Models are available to provide the proper flow response required by the application.

Controllers & Sensors

197-205

Understanding a Control Loop

197

Controllers – Design & Operation

198-199

TR890 Series Electronic PID Controller

200-201

TA901 Series Electropneumatic I/P Transducer

202

TA987 Air Filter/ Regulator (for TA901 Pneumatic Control Device)

203

Electronic Temperature Sensors (RTD or Thermocouple)

204

Thermowells (for Temperature Sensors)

205

CONTROL VALVES

W910 Series

Compact Control Valve

Watson McDaniel reserves the right to change the designs and/or materials of its products without notice.
©2010 Watson McDaniel Company

Models	W910A, W910B, W910C, W910TB, W910EPA, W910EPC
Service	Water, Steam, Other Liquids
Sizes	1/2", 3/4", 1", 1 1/4", 1 1/2", 2", 2 1/2", 3", 4"
Connections	Union Ends, 125# Flanged, 250# Flanged (optional)
Body Material	1/2" – 2" Bronze, 2 1/2" – 4" Cast Iron
Seat Material	Stainless Steel
Max. Inlet Pressure	250 PSIG

DESIGN PRESSURE/TEMPERATURE RATING – PMA/TMA

Union Ends 250 PSIG @ 450° F
125# FLG 125 PSIG @ 450° F



Description

A control valve is a device capable of modulating flow at varying degrees between minimal flow and full capacity in response to a signal from an external control device. The control valve, often referred to as "the final control element," is a critical part of any control loop, as it performs the physical work and is the element that directly affects the process.

Principles of Operation

A control valve is comprised of an actuator mounted to a valve. The valve modulates flow through movement of a valve plug in relation to the port(s) located within the valve body. The valve plug is attached to a valve stem, which, in turn, is connected to the actuator. The actuator, which can be pneumatically or electrically operated, directs the movement of the stem as dictated by the external control device.

Pneumatic/Diaphragm Actuated

Watson McDaniel Pneumatic Actuators are direct acting and utilize an air signal from an external control device to create a modulating control action. The force of the air signal is received into the actuator through a top port and distributed across the full area of the actuator's diaphragm. The diaphragm presses down on the diaphragm plate and spring return assembly, which then moves the valve stem and plug assembly downward to stroke the valve. This actuator will move to a stem-out position in the event of air signal failure. The choice of valve action (stem-In-To-Close or stem-In-To-Open) will determine its signal failure position.

The **W910 Series Pneumatic Control Valve** offers high quality at an economical price, incorporating many features found only on more expensive units. The following Models are available to provide the proper flow response required by the application:

- ▶ The **W910A, W910B & W910C** are used for On/Off control applications, providing a quick-opening flow response when used with single or double seated valves.
- ▶ The **W910TB** is used for proportional or PID control applications, providing a throttling flow response when used with double seated or 3-way valves.
- ▶ The **W910EPA & W910EPC** are used for proportional or PID control applications, providing equal percentage flow response when used with single seated valves.

CONTROL VALVES

W910 Series

Compact Control Valve

Specifications

Actuator Model	Diaphragm Size	Control Action	Input Signal
W910A	7"	On/Off	15 PSIG
W910B	10"	On/Off	15 PSIG
W910C	12"	On/Off	15 PSIG
W910TB	10"	Throttling*	3-15 PSIG
W910EPA	7"	Equal Percentage	3-15 PSIG
W910EPC	12"	Equal Percentage	3-15 PSIG

* Includes 3-Way Valves

Actuator Housing

Die cast aluminum, epoxy powder coated blue finish.

Setting Scale

Integral to housing

Adjustment Screw

Brass

Adjustment Screw Bushing

Lubricant impregnated sintered bronze

Range Adjustment Spring

Cadmium plated

Pressure Plate

Aluminum

Diaphragm

Nylon reinforced EDPM

Air Pressure to Diaphragm

30 PSIG maximum

Air Pressure Connection

1/8" NPT Female

Operating Temperature

Ambient:

-40°F (-40°C) to 180°F (82°C)

Process Flow:

-40°F (-40°C) to 410°F (210°C)

Units: inches [mm]

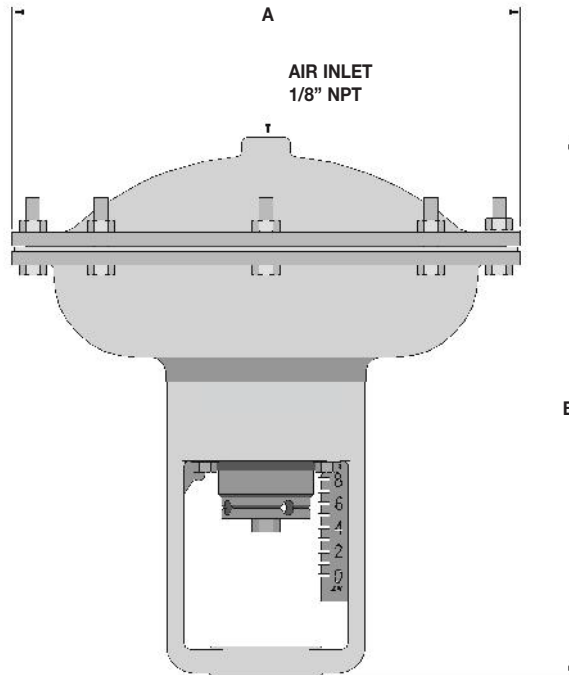

Actuator Number	A	B	Approx. Shipping Weight
W910A	7.0 [178]	9.8 [249]	6.6 lbs [2.97 kg]
W910B	9.3 [236]	9.8 [249]	8.5 lbs [3.83 kg]
W910C	11.4 [290]	9.8 [249]	12.0 lbs [5.41 kg]
W910TB	9.3 [236]	9.8 [249]	9.6 lbs [4.32 kg]
W910EPA	7.0 [178]	9.8 [249]	7.6 lbs [3.42 kg]
W910EPC	11.4 [290]	9.8 [249]	13.1 lbs [5.90 kg]

Actuator

- W910 Series Pneumatic Actuators are used in conjunction with the W910 Series Control Valve. Choose the appropriate Actuator model based on the intended service.

HOW TO ORDER

Sample Order Number: **W910TB - A56**

Actuator Model	Control Action	Valve Body Number
W910A W910B W910C	On/Off	Refer to pages 188-190
W910TB	Throttling	Refer to pages 191-193
W910EPA W910EPC	Equal Percentage	Refer to page 188

Procedure:

- Determine the Actuator Model (W910A, W910B, W910C, W910TB, W910EPA or W910EPC) required.

Note: Refer to the maximum close-off pressure columns in the Valve Body Selection tables to determine the Actuator size required by your application.

- Determine the Valve Body Number based on the Valve Size, style and material required by the application.

Note: Consult the Valve Selection tables on the following pages to determine the required Valve Body Number.

CONTROL VALVES

W910 Series

Valve Body for W910A, W910B, W910C, W910EPA & W910EPC

BRONZE

Single Seat • 1/2" – 2"

**Stem In-To-Close
(normally open)**

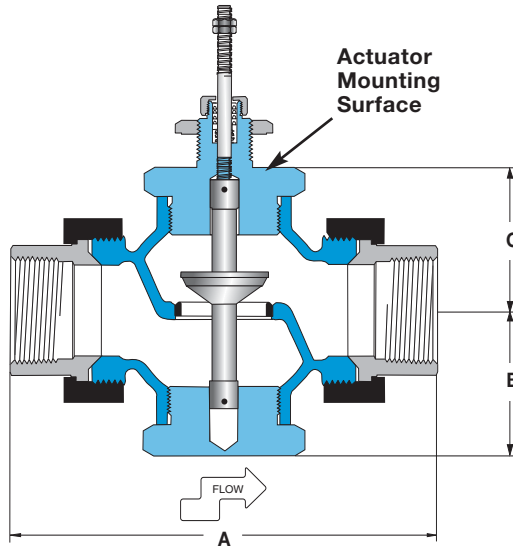

**Stem In-To-Open
(normally closed)**

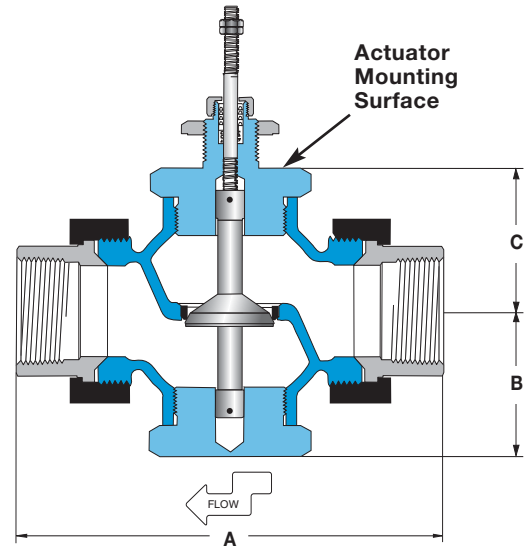

CONTROL VALVES

Specifications

Body Material	Trim Material	Trim Style	Connection	Pressure & Temperature Rating
Bronze	Stainless Steel	ML or EP	NPT with Malleable Iron Union Ends	250 PSI @ 410°F (210°C)

ML = Modified Linear (On/Off); EP = Equal Percentage

Valve Body Selection

In-To-Close (Normally Open)				Maximum Close-Off Pressure (PSI ΔP)				Dimensions			Approximate Shipping Wt.
Valve Body No. ML	EP	Size Connection (NPT)	C _v	W910A	W910B	W910C	W910EPC	A	B	C	
A14	E14	1/2"	2.8	250	x	x	250	4.8 [122]	1.8 [46]	1.8 [46]	3.0 lbs [1.35 kg]
A19	E19	3/4"	5.6	250	x	x	250	5.6 [142]	2.3 [58]	2.3 [58]	4.9 lbs [2.21 kg]
A26	E26	1"	8.4	200	250	x	200	6.0 [152]	2.3 [58]	2.3 [58]	6.0 lbs [2.70 kg]
A36	E36	1 1/4"	15	100	250	x	150	7.2 [183]	2.6 [66]	2.6 [66]	9.7 lbs [4.37 kg]
A47	E47	1 1/2"	21	50	150	250	100	7.7 [196]	2.6 [66]	2.6 [66]	10.8 lbs [4.86 kg]
A58	E58	2"	33	25	50	250	50	8.6 [218]	3.1 [79]	3.1 [79]	16.3 lbs [7.34 kg]

In-To-Open (Normally Closed)				Maximum Close-Off Pressure (PSI ΔP)				Dimensions			Approximate Shipping Wt.
Valve Body No. ML	EP	Size Connection (NPT)	C _v	W910A	W910B	W910C	W910EPA	A	B	C	
A15	E15	1/2"	2.8	250	x	x	250	4.8 [122]	1.8 [46]	1.8 [46]	3.0 lbs [1.35 kg]
A22	E22	3/4"	5.6	250	x	x	250	5.6 [142]	2.3 [58]	2.3 [58]	4.9 lbs [2.21 kg]
A30	E30	1"	8.4	200	x	x	200	6.0 [152]	2.3 [58]	2.3 [58]	6.0 lbs [2.70 kg]
A41	E41	1 1/4"	15	150	x	x	150	7.2 [183]	2.6 [66]	2.6 [66]	9.7 lbs [4.37 kg]
A52	E52	1 1/2"	21	100	x	x	100	7.7 [196]	2.6 [66]	2.6 [66]	10.8 lbs [4.86 kg]
A63	E63	2"	33	50	x	x	50	8.6 [218]	3.1 [79]	3.1 [79]	16.3 lbs [7.34 kg]

All dimensions are inches [mm].

CONTROL VALVES

W910 Series

BRONZE

Valve Body for W910A, W910B & W910C

Double Seat • 3/4" – 2"

**Stem In-To-Close
(normally open)**

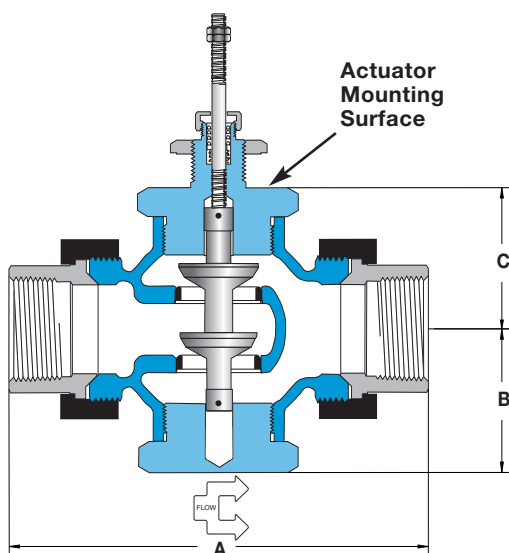

**Stem In-To-Open
(normally closed)**

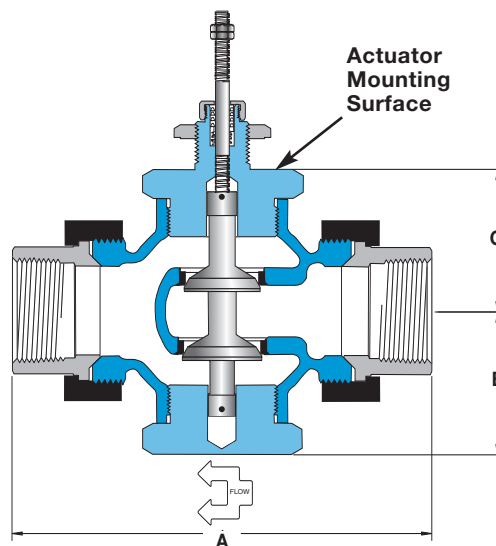

CONTROL VALVES

Specifications

Body Material	Trim Material	Trim Style	Connection	Pressure & Temperature Rating
Bronze	Stainless Steel	Modified Linear	NPT with Malleable Iron Union Ends	250 PSI @ 410°F (210°C)

Valve Body Selection

In-To-Close (Normally Open)				Maximum Close-Off Pressure (PSI ΔP)			Dimensions			Approximate Shipping Wt.
Valve Body Number	Size		C _v	W910A	W910B	W910C	A	B	C	
	Connection (NPT)	Nominal Port								
A21	3/4"	3/4"	8	250	x	x	5.6 [142]	2.3 [58]	2.3 [58]	5.0 lbs [2.25 kg]
A29	1"	1"	12	250	x	x	6.0 [152]	2.3 [58]	2.3 [58]	6.1 lbs [2.75 kg]
A39	1 1/4"	1 1/4"	21	250	x	x	7.2 [183]	2.6 [66]	2.6 [66]	10.1 lbs [4.55 kg]
A50	1 1/2"	1 1/2"	30	250	x	x	7.7 [196]	2.6 [66]	2.6 [66]	11.1 lbs [5.00 kg]
A61	2"	2"	47	200	x	x	8.6 [218]	3.1 [79]	3.1 [79]	17.0 lbs [7.65 kg]

In-To-Open (Normally Closed)				Maximum Close-Off Pressure (PSI ΔP)			Dimensions			Approximate Shipping Wt.
Valve Body Number	Size		C _v	W910A	W910B	W910C	A	B	C	
	Connection (NPT)	Nominal Port								
A24	3/4"	3/4"	8	250	x	x	5.6 [142]	2.3 [58]	2.3 [58]	5.0 lbs [2.25 kg]
A33	1"	1"	12	250	x	x	6.0 [152]	2.3 [58]	2.3 [58]	6.1 lbs [2.75 kg]
A44	1 1/4"	1 1/4"	21	250	x	x	7.2 [183]	2.6 [66]	2.6 [66]	10.1 lbs [4.55 kg]
A55	1 1/2"	1 1/2"	30	250	x	x	7.7 [196]	2.6 [66]	2.6 [66]	11.1 lbs [5.00 kg]
A66	2"	2"	47	200	x	x	8.6 [218]	3.1 [79]	3.1 [79]	17.0 lbs [7.65 kg]

All dimensions are inches [mm].

CONTROL VALVES

W910 Series

Valve Body for W910A, W910B & W910C

CAST IRON

Double Seat • 2½" – 4"

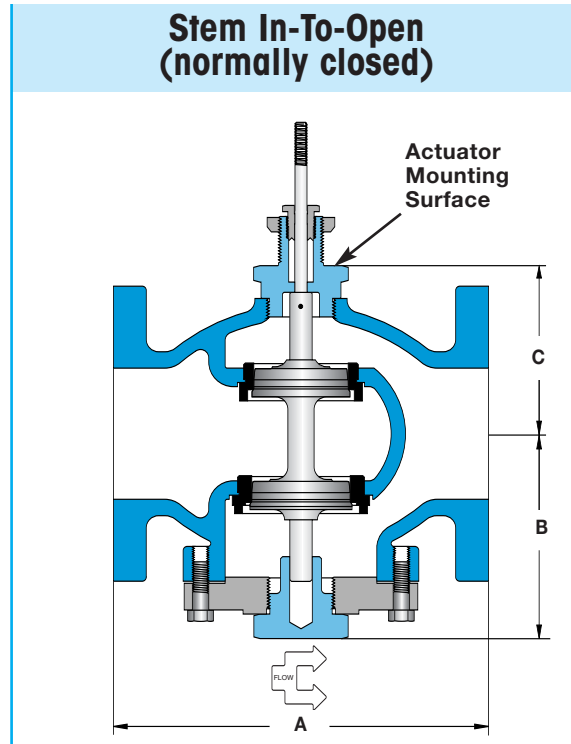
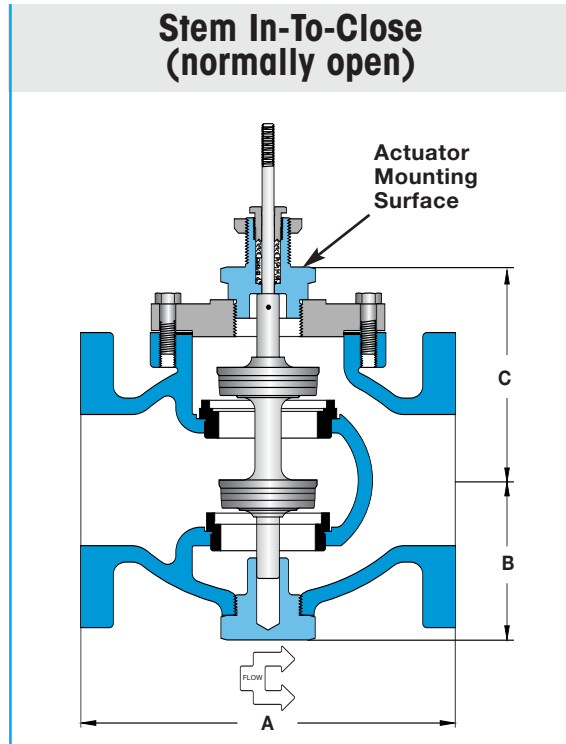

CONTROL VALVES

Specifications

Body Material	Trim Material	Trim Style	Connection	Pressure & Temperature Rating
Cast Iron	Stainless Steel	Modified Linear	125# Flanged	125 PSI @ 350°F (176°C)

Valve Body Selection

In-To-Close (Normally Open)				Maximum Close-Off Pressure (PSI ΔP)			Dimensions			Approximate Shipping Wt.
Valve Body Number	Size		C _v	W910A	W910B	W910C	A	B	C	
	Connection	Nominal Port								
B73	2½"	2½"	69	125	x	x	7.8 [198]	4.8 [122]	5.4 [137]	45 lbs [20 kg]
B78	3"	3"	90	125	x	x	9.0 [229]	5.0 [127]	5.6 [142]	70 lbs [32 kg]
B83	4"	4"	196	125	x	x	11.4 [290]	6.3 [160]	6.5 [165]	100 lbs [45 kg]

In-To-Open (Normally Closed)				Maximum Close-Off Pressure (PSI ΔP)			Dimensions			Approximate Shipping Wt.
Valve Body Number	Size		C _v	W910A	W910B	W910C	A	B	C	
	Connection	Nominal Port								
B74	2½"	2½"	69	125	x	x	7.8 [198]	4.8 [122]	5.4 [137]	45 lbs [20 kg]
B79	3"	3"	90	125	x	x	9.0 [229]	5.0 [127]	5.6 [142]	70 lbs [32 kg]
B84	4"	4"	196	125	x	x	11.4 [290]	6.3 [160]	6.5 [165]	100 lbs [45 kg]

All dimensions are inches [mm].

BRONZE

Single or Double Seat
1/2" – 2"

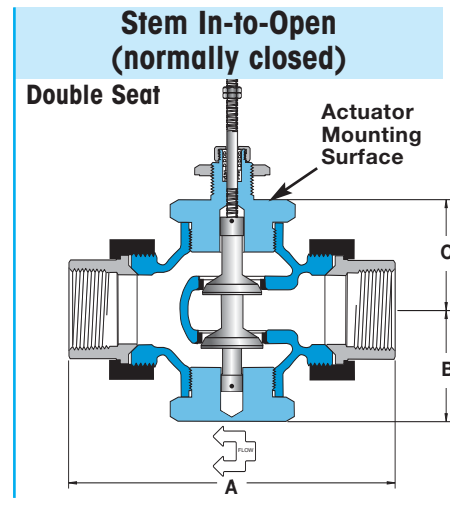
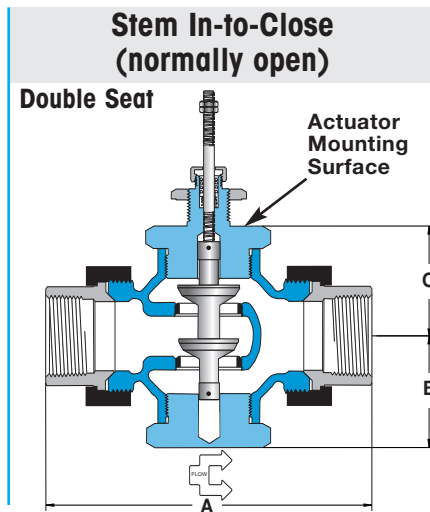
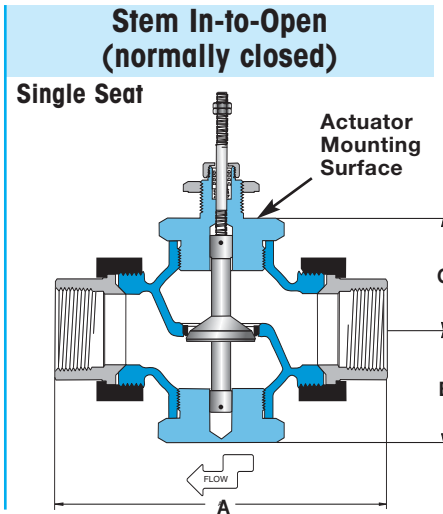
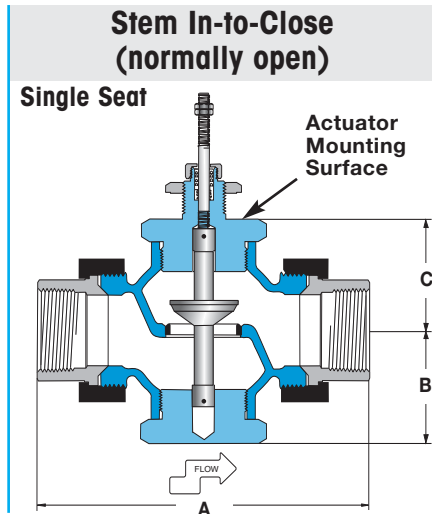

CONTROL VALVES

Specifications

Body Material	Trim Material	Trim Style	Connection	Pressure & Temperature Rating
Bronze	Stainless Steel	Modified Linear	NPT with Malleable Iron Union Ends	250 PSI @ 410°F (210°C)

Valve Body Selection

Valve Body Number	ITC Normally Open	ITO Normally Closed	Size		Number of Seats	C _v	Maximum Close-Off Pressure (PSI ΔP) Actuator W910TB	Dimensions			Approximate Shipping Wt.
			Connection (NPT)	Nominal Port				A	B	C	
A02	A03	1/2"	1/8"	1	0.17	250	4.8 [122]	1.8 [46]	1.8 [46]	3.0 lbs [1.35 kg]	
A05	A06	1/2"	3/16"	1	0.35	250	4.8 [122]	1.8 [46]	1.8 [46]	3.0 lbs [1.35 kg]	
A08	A09	1/2"	1/4"	1	0.7	250	4.8 [122]	1.8 [46]	1.8 [46]	3.0 lbs [1.35 kg]	
A11	A12	1/2"	3/8"	1	1.4	250	4.8 [122]	1.8 [46]	1.8 [46]	3.0 lbs [1.35 kg]	
A14	A15	1/2"	1/2"	1	2.8	250	4.8 [122]	1.8 [46]	1.8 [46]	3.0 lbs [1.35 kg]	
A21	A24	3/4"	3/4"	2	8	250	5.6 [142]	2.3 [58]	2.3 [58]	5.0 lbs [2.25 kg]	
A29	A33	1"	1"	2	12	250	6.0 [152]	2.3 [58]	2.3 [58]	6.1 lbs [2.75 kg]	
A39	A44	1 1/4"	1 1/4"	2	21	250	7.2 [183]	2.6 [66]	2.6 [66]	10.1 lbs [4.55 kg]	
A50	A55	1 1/2"	1 1/2"	2	30	250	7.7 [196]	2.6 [66]	2.6 [66]	11.1 lbs [5.00 kg]	
A61	A66	2"	2"	2	47	250	8.6 [218]	3.1 [79]	3.1 [79]	17.0 lbs [7.65 kg]	

All dimensions are inches [mm].

CONTROL VALVES

W910 Series

Valve Body for W910TB

BRONZE

3-Way • 1/2" – 2"

for Mixing or Diverting

**MIXING
FLOW DIAGRAM**

**DIVERTING
FLOW DIAGRAM**

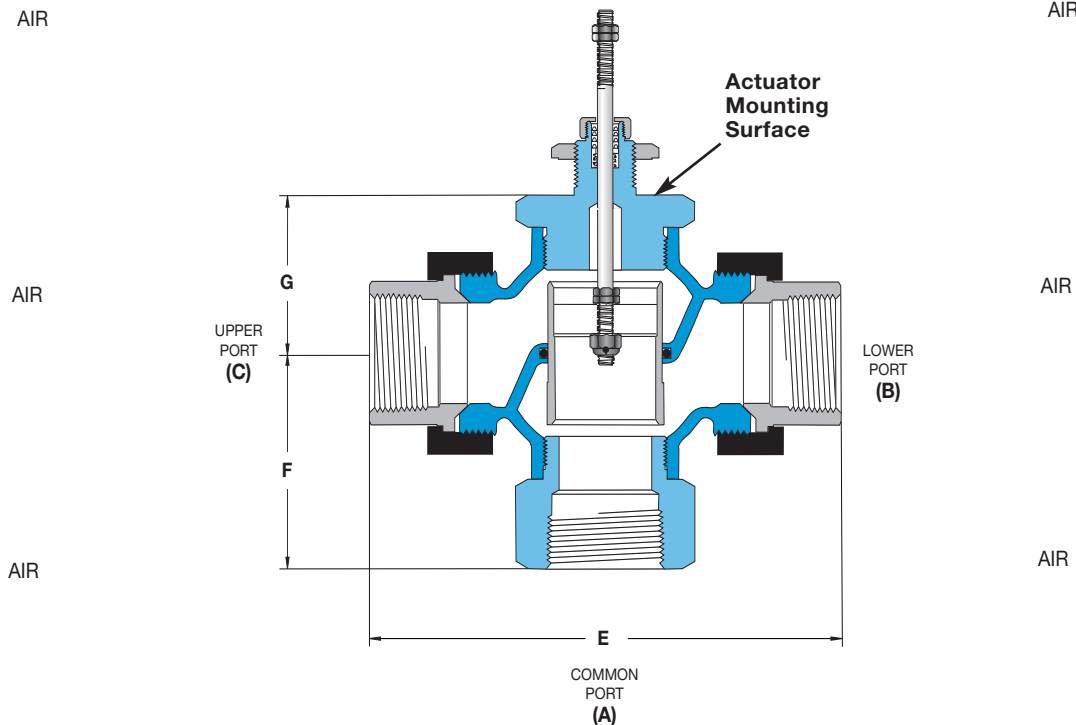

CONTROL VALVES

CAUTION: 3-Way Valves are not designed for use in steam applications. To properly control the mixing of two flows, inlet pressures at ports B and C should be as equal as possible.

Specifications

Body Material	Trim Material	Trim Style	Connection	Pressure & Temperature Rating
Bronze	Bronze	Modified Linear	NPT with Malleable Iron Union Ends	250 PSI @ 300°F (149°C)

Valve Body Selection

Mixing or Diverting				Maximum Close-Off Pressure (PSI ΔP)				
Valve Body Number	Size		C _v	Actuator W910TB	Dimensions			Approximate Shipping Wt.
	Connection (NPT)	Nominal Port			E	F	G	
A18	1/2"	1/2"	2.8	250	4.8 [122]	1.8 [46]	1.8 [46]	2.9 lbs [1.31 kg]
A25	3/4"	3/4"	5.6	250	5.6 [142]	2.3 [58]	2.3 [58]	4.7 lbs [2.12 kg]
A34	1"	1"	8.4	250	6.0 [152]	2.3 [58]	2.3 [58]	5.7 lbs [2.57 kg]
A45	1 1/4"	1 1/4"	15	250	7.2 [183]	2.8 [71]	2.6 [66]	9.5 lbs [4.28 kg]
A56	1 1/2"	1 1/2"	21	250	7.7 [196]	3.5 [89]	2.6 [66]	11.1 lbs [5.00 kg]
A67	2"	2"	33	250	8.6 [218]	4.1 [104]	3.1 [79]	16.7 lbs [7.55 kg]

All dimensions are inches [mm].

CAST IRON

CONTROL VALVES

W910 Series

Valve Body for W910TB

3-Way • 2 1/2" – 4"

for Mixing or Diverting

MIXING
FLOW DIAGRAM

DIVERTING
FLOW DIAGRAM

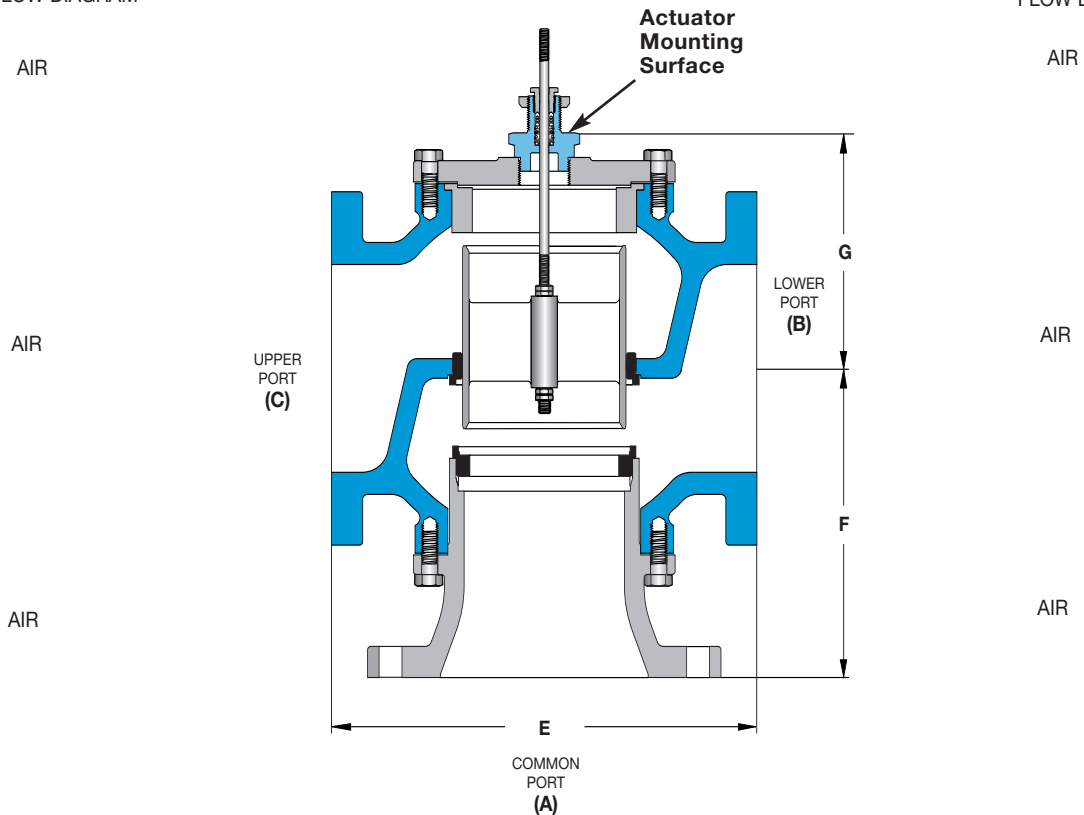

CONTROL
VALVES

CAUTION: 3-Way Valves are not designed for use in steam applications. To properly control the mixing of two flows, inlet pressures at ports B and C should be as equal as possible.

Specifications

Body Material	Trim Material	Trim Style	Connection	Pressure & Temperature Rating
Cast Iron	Bronze	Modified Linear	125# Flanged	125 PSI @ 300°F (149°C)

Valve Body Selection

Mixing or Diverting			Maximum Close-Off Pressure (PSI ΔP)		Dimensions			Approximate Shipping Wt.
Valve Body Number	Size Connection (NPT)	Nominal Port	C _v	Actuator W910TB	E	F	G	
B75	2 1/2"	2 1/2"	58	125	9.0 [229]	7.1 [180]	5.2 [132]	62 lbs [28 kg]
B80	3"	3"	72	125	10.0 [254]	8.0 [203]	6.0 [152]	80 lbs [36 kg]
B85	4"	4"	102	125	13.0 [330]	10.0 [254]	6.9 [175]	140 lbs [64 kg]

All dimensions are inches [mm].

CONTROL VALVES

W910 Series

Capacity Charts

CAPACITIES – Steam (lbs/hr)		SINGLE SEATED VALVES					
Inlet Pressure (PSIG)	Size, Body Number & Coefficient (Cv)						
	1/2"	3/4"	1"	1 1/4"	1 1/2"	2"	
	A14/E14 ITC Cv = 2.8	A19/E19 ITC Cv = 5.6	A26/E26 ITC Cv = 8.4	A36/E36 ITC Cv = 15	A47/E47 ITC Cv = 21	A58/E58 ITC Cv = 33	
1	80	160	240	428	599	942	
3	90	180	270	483	676	1062	
5	100	201	301	537	752	1182	
10	126	252	377	674	943	1482	
15	151	302	454	810	1134	1782	
20	177	353	530	946	1325	2082	
25	202	404	606	1083	1516	2382	
30	228	455	683	1219	1701	2682	
40	279	557	838	1492	2089	3283	
50	329	659	988	1765	2471	3883	
60	380	761	1141	2038	2853	4483	
70	431	863	1294	2310	3235	5083	
80	482	964	1447	2583	3617	5683	
90	533	1066	1599	2856	3999	6283	
100	584	1168	1752	3129	4380	6884	
125	711	1423	2134	3811	5335	8384	
150	839	1677	2516	4493	6290	9884	
175	966	1932	2898	5175	7245	11385	
200	1093	2187	3280	5857	8200	12885	
250	1348	2696	4044	7221	10109	15886	

Note:
Verify that Maximum Close-Off Pressure does not exceed max rating for selected valve body number and actuator. (Refer to Valve Body No. charts for Single Seated Valves.)

Note: All steam capacities based on Critical Drop (Choked Flow).

CAPACITIES – Water (GPM)		SINGLE SEATED VALVES					
Pressure Drop (PSI ΔP)	Size, Body Number & Coefficient (Cv)						
	1/2"	3/4"	1"	1 1/4"	1 1/2"	2"	
	A14/E14 ITC A15/E15 ITO Cv = 2.8	A19/E19 ITC A22/E22 ITO Cv = 5.6	A26/E26 ITC A30/E30 ITO Cv = 8.4	A36/E36 ITC A41/E41 ITO Cv = 15	A47/E47 ITC A52/E52 ITO Cv = 21	A58/E58 ITC A63/E63 ITO Cv = 33	
1	2.8	5.6	8.4	15	21	33	
3	4.8	10	15	26	36	57	
5	6.3	13	19	34	47	74	
10	8.9	18	27	47	66	104	
15	11	22	33	58	81	128	
20	13	25	38	67	94	148	
25	14	28	42	75	105	165	
30	15	31	46	82	115	181	
40	18	35	53	95	133	209	
50	20	40	59	106	148	233	
60	22	43	65	116	163	256	
70	23	47	70	125	176	276	
80	25	50	75	134	188	295	
90	27	53	80	142	199	313	
100	28	56	84	150	210	330	
125	31	63	94	168	235	369	
150	34	69	103	184	257	404	
175	37	74	111	198	278	437	
175	37	74	111	198	278	437	
200	40	79	119	212	297	467	
225	42	84	126	225	315	495	
250	44	89	133	237	332	522	

Note:
Verify that Maximum Close-Off Pressure does not exceed max rating for selected valve body number and actuator. (Refer to Valve Body No. charts for Single Seated Valves.)

ITC = In-to-Close; ITO = In-to-Open

CONTROL VALVES

W910 Series

Capacity Charts

CAPACITIES – Steam (lbs/hr)		DOUBLE SEATED VALVES						
Inlet Pressure (PSIG)	Size, Body Number & Coefficient (Cv)							
	3/4"	1"	1 1/4"	1 1/2"	2"	2 1/2"	3"	4"
	A21 ITC Cv = 8	A29 ITC Cv = 12	A39 ITC Cv = 21	A50 ITC Cv = 30	A61 ITC Cv = 47	B73 ITC Cv = 69	B78 ITC Cv = 90	B83 ITC Cv = 196
1	288	343	599	856	1342	1970	2569	5595
3	257	386	676	965	1513	2221	2896	6308
5	287	430	752	1075	1684	2472	3224	7021
10	359	539	943	1347	2111	3099	4042	8803
15	432	648	1134	1620	2538	3726	4861	10585
20	505	757	1325	1893	2966	4354	5679	12368
25	578	866	1516	2166	3393	4981	6497	14150
30	650	975	1707	2439	3820	5609	7316	15932
40	796	1194	2089	2984	4675	6864	8953	19497
50	941	1412	2471	3530	5530	8119	10589	23080
60	1087	1630	2853	4075	6385	9380	12240	26650
70	1232	1848	3235	4621	7240	10640	13870	30210
80	1378	2067	3617	5167	8094	11890	15510	33780
90	1523	2285	3999	5712	8949	13150	17150	37350
100	1669	2503	4380	6258	9804	14400	18790	40920
125	2032	3049	5335	7622	11941	17540	22880	49830
150	2396	3594	6290	8986	14078			
175	2760	4140	7245	10350	16215			
200	3124	4685	8200	11714	18352			
250	3851	5777	10109	14442	22625			

Note: All steam capacities based on Critical Drop (Choked Flow).

CAPACITIES – Water (GPM)		DOUBLE SEATED VALVES						
Pressure Drop (PSI ΔP)	Size, Body Number & Coefficient (Cv)							
	3/4"	1"	1 1/4"	1 1/2"	2"	2 1/2"	3"	4"
	A21 ITC A24 ITO Cv = 8	A29 ITC A33 ITO Cv = 12	A39 ITC A44 ITO Cv = 21	A50 ITC A55 ITO Cv = 30	A61 ITC A66 ITO Cv = 47	B73 ITC B74 ITO Cv = 69	B78 ITC B79 ITO Cv = 90	B83 ITC B84 ITO Cv = 196
1	8	12	21	30	47	69	90	196
3	14	21	36	52	81	120	156	339
5	18	27	47	67	105	154	201	438
10	25	38	66	95	149	218	285	620
15	31	46	81	116	182	267	349	759
20	36	54	94	134	210	309	402	877
25	40	60	105	150	235	345	450	980
30	44	66	115	164	257	378	493	1074
40	51	76	133	190	297	436	569	1240
50	57	85	148	212	332	488	636	1386
60	62	93	163	232	364	534	697	1518
70	67	100	176	251	393	577	753	1640
80	72	107	188	268	420	617	805	1753
90	76	114	199	285	446	655	854	1859
100	80	120	210	300	470	690	900	1960
125	89	134	235	335	525	771	1006	2191
150	98	147	257	367	576			
175	106	159	278	397	622			
200	113	170	297	424	665			
225	120	180	315	450	705			
250	126	190	332	474	743			

ITC = In-to-Close; ITO = In-to-Open

CONTROL VALVES

CONTROL VALVES

W910 Series

Capacity Charts

CAPACITIES – Water (GPM)

3-WAY VALVES

Inlet pressures should be within 5% of each other. Specify if service is for other than water.

Pressure Drop (PSI ΔP)	Size, Body Number & Coefficient (Cv)								
	1/2"	3/4"	1"	1 1/4"	1 1/2"	2"	2 1/2"	3"	4"
	A18 Cv = 2.8	A25 Cv = 5.6	A34 Cv = 8.4	A45 Cv = 15	A56 Cv = 21	A67 Cv = 33	B75 Cv = 58	B80 Cv = 72	B85 Cv = 102
1	2.8	5.6	8.4	15	21	33	58	72	102
3	4.8	10	15	26	36	57	100	125	177
5	6.3	13	19	34	47	74	130	161	228
10	8.9	18	27	47	66	104	183	228	323
15	11	22	33	58	81	128	225	279	395
20	13	25	38	67	94	148	259	322	456
25	14	28	42	75	105	165	290	360	510
30	15	31	46	82	115	181	318	394	559
40	18	35	53	95	133	209	367	455	645
50	20	40	59	106	148	233	410	509	721
60	22	43	65	116	163	256	449	558	790
70	23	47	70	125	176	276	485	602	853
80	25	50	75	134	188	295	519	644	912
90	27	53	80	142	199	313	550	683	968
100	28	56	84	150	210	330	580	720	1020
125	31	63	94	168	235	369	648	805	1140
150	34	69	103	184	257	404			
175	37	74	111	198	278	437			
200	40	79	119	212	297	467			
225	42	84	126	225	315	495			
250	44	89	133	237	332	522			

Note: Oil service or high temperature service requires special O-ring.

CAPACITIES – Steam (lbs/hr) SINGLE SEATED

Inlet Pressure (PSIG)	Size, Body Number & Coefficient (Cv)			
	1/8"	3/16"	1/4"	3/8"
	Reduced Port A02 ITC Cv = 0.17	Reduced Port A05 ITC Cv = 0.35	Reduced Port A08 ITC Cv = 0.7	Reduced Port A11 ITC Cv = 1.4
1	4.9	10	20	40
3	5.5	11	23	45
5	6.1	13	25	50
10	7.6	16	31	63
15	9.2	19	38	76
20	11	22	44	88
25	12	25	51	101
30	14	28	57	114
40	17	35	70	139
50	20	41	82	165
60	23	48	95	190
70	26	54	108	216
80	29	60	121	241
90	32	67	133	267
100	35	73	146	292
125	43	89	178	356
150	51	105	210	419
175	59	121	241	483
200	66	137	273	547
250	82	168	337	674

Note: All steam capacities based on Critical Drop (Choked Flow).

CAPACITIES – Water (GPM) SINGLE SEATED

Pressure Drop (PSI ΔP)	Size, Body Number & Coefficient (Cv)			
	1/8"	3/16"	1/4"	3/8"
	Reduced Port A02 ITC A03 ITO Cv = 0.17	Reduced Port A05 ITC A06 ITO Cv = 0.35	Reduced Port A08 ITC A09 ITO Cv = 0.7	Reduced Port A11 ITC A12 ITO Cv = 1.4
1	0.2	0.4	0.7	1.4
3	0.3	0.6	1.2	2.4
5	0.4	0.8	1.6	3.1
10	0.5	1.1	2.2	4.4
15	0.7	1.4	2.7	5.4
20	0.8	1.6	3.1	6.3
25	0.9	1.8	3.5	7.0
30	0.9	1.9	3.8	7.7
40	1.1	2.2	4.4	8.9
50	1.2	2.5	4.9	10
60	1.3	2.7	5.4	11
70	1.4	2.9	5.9	12
80	1.5	3.1	6.3	13
90	1.6	3.3	6.6	13
100	1.7	3.5	7.0	14
125	1.9	3.9	7.8	16
150	2.1	4.3	8.6	17
175	2.2	4.6	9.3	19
200	2.4	4.9	10	20
250	2.7	5.5	11	22

ITC = In-to-Close; ITO = In-to-Open

Control Loop

Understanding a Control Loop

SEMI-INSTANTANEOUS WATER HEATER TEMPERATURE CONTROL LOOP

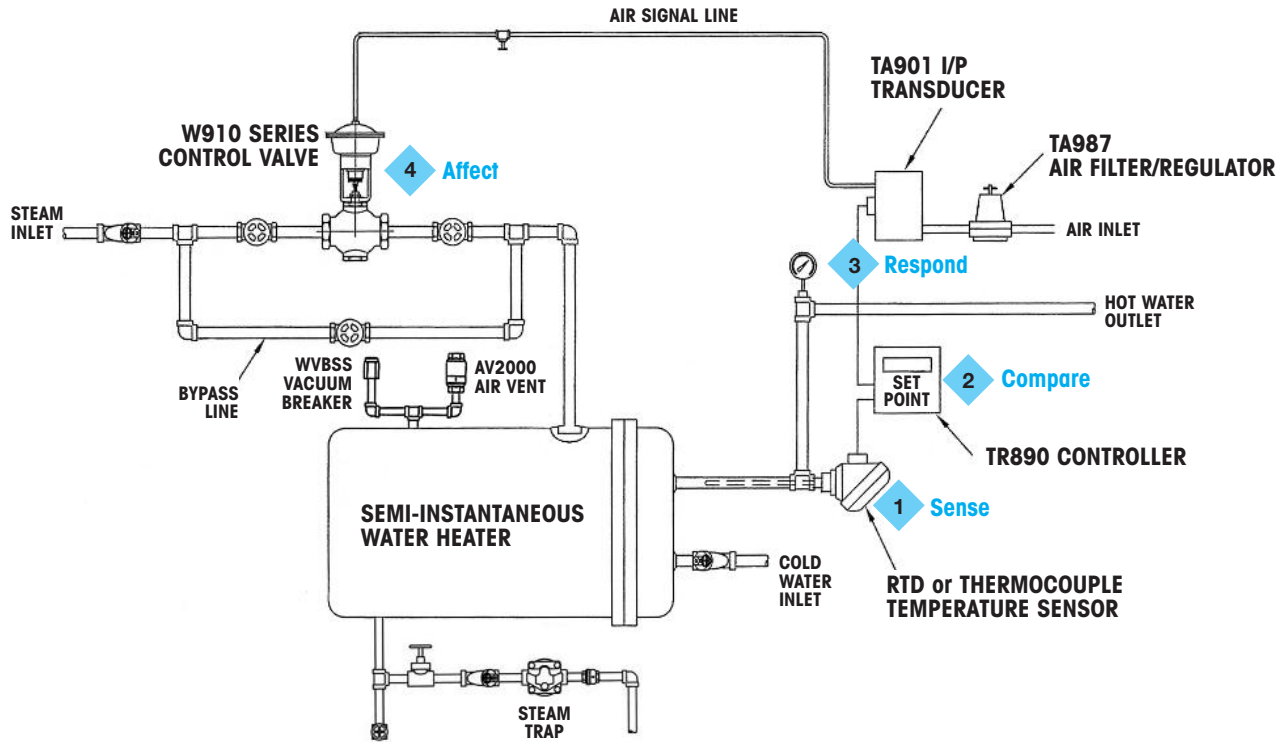

CONTROL VALVES

Control Loop

A control loop is a process management system designed to maintain a process variable at a desired set point. Each step in the loop works in conjunction with the others to manage the system. Once the set point has been established, the control loop operates using a four-step process.

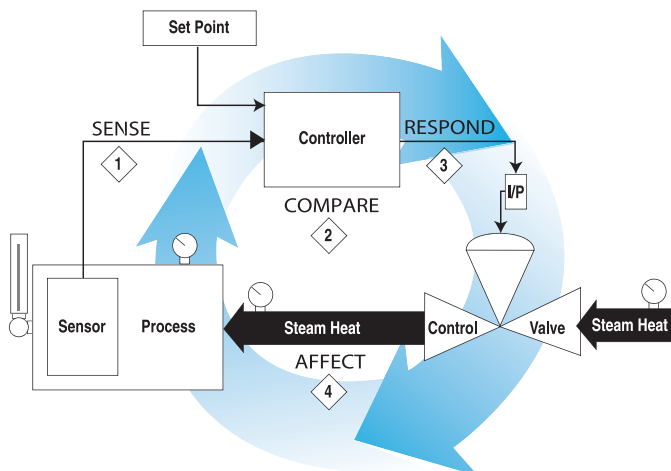

1 Sense

Measure the current condition of the process using a sensor, which can be an electronic (thermocouple, RTD or transmitter) or mechanical device (thermal system).

2 Compare

Evaluate the measurement of the current condition against the set point using an electronic or electric contact controller.

3 Respond

React to any error that may exist between the measured value and set point by generating a corrective pneumatic or electric control signal.

4 Affect

Actuate a final control element (valve, heater or other device) that will produce a change in the process variable.

The loop continually cycles through the steps, affecting the process variable in order to maintain the desired set point. Watson McDaniel is unique in its ability to provide all of the necessary components to create a complete control loop.

Controllers

Design & Operation

Description

A controller is a comparative device that receives an input signal from a measured process variable, compares this value with that of a predetermined control point value (set point), and determines the appropriate amount of output signal required by the final control element to provide corrective action within a control loop. Watson McDaniel offers an **Electronic PID Controller**, which uses electrical signals and digital algorithms to perform its receptive, comparative and corrective functions.

Principles of Operation (Electronic PID Controller)

An electronic sensor (thermocouple, RTD or transmitter) installed at the measurement location continuously sends an input signal to the controller. At set intervals, the controller compares this signal to a predefined set point. If the input signal deviates from the set point, the controller sends a corrective electric output signal to the control element. This electric signal must be converted to a pneumatic signal when used with an air operated valve, such as a Watson McDaniel W910 Series Control Valve. The conversion can be made using a Watson McDaniel TA901 I/P Transducer, which converts a 4 to 20 mA electric signal to a 3 to 15 PSI air signal.

Features (Electronic PID Controller)

An electronic controller is best suited for applications where large load changes are encountered and/or fast response changes are required. Watson McDaniel Electronic Controllers have full auto-tuning and PID capabilities, and offer a host of available options, including user selectable inputs and ranges, outputs, setback functions and alarms.

PID Control is a feature of most Watson McDaniel Electronic Controllers. PID combines the proportional, integral and derivative functions into a single unit.

- **Proportional (P)** — Proportional control reacts to the size of the deviation from set point when sending a corrective signal. The size of the corrective signal can be adjusted in relation to the size of the error by changing the width of the proportional band. A narrow proportional band will cause a large corrective action in relation to a given amount of error, while a wider proportional band will cause a smaller corrective action in relation to the same amount of error.
- **Integral (I)** — Integral control reacts to the length of time that the deviation from set point exists when sending a corrective signal. The longer the error exists, the greater the corrective signal.
- **Derivative (D)** — Derivative control reacts to the speed in which the deviation is changing. The corrective signal will be proportional to the rate of change within the process.

Auto-Tuning

Auto-tuning will automatically select the optimum values for **P**, **I** and **D**, thus eliminating the need for the user to calculate and program these values at system startup. This feature can be overridden when so desired. On some models, the control element can be manually operated.

Selecting an Electronic PID Controller

All Watson McDaniel Electronic Controllers are designed to control the temperature or pressure of general industrial equipment and should be carefully selected to meet the demands of the particular application. The information contained within this catalog is offered only as a guide to assist in making the proper selection. Selection of the proper controller is the sole responsibility of the user. Improper application may cause process failure, resulting in possible personal injury or property damage.

Case Size

Case Size selection is determined by both available and designed space, and controller features. Watson McDaniel Electronic Controllers are available in the following panel sizes: 48 x 48 mm ($1/16$ DIN), 72 x 72 mm, 96 x 96 mm ($1/4$ DIN) and 48 x 96 mm ($1/8$ DIN). The depth of the unit varies with the model selected.

Input

The Input is the measurement signal received by the controller from the sensor. A variety of input types are available, including thermocouple, RTD, voltage and current.

Control Output

The Control Output is the corrective signal transmitted from the controller to the control element. Various control output types are available, including contact, voltage, current and solid state relay driver.

Analog Output

The Analog Output is an optional secondary signal that transmits the measurement signal from the controller to a remote data acquisition device, such as a recorder, personal computer or display unit.

Alarms

Most models can be ordered with alarms, event outputs, or heater break alarms, which signal an external device to perform a specific task at a predetermined set point.

Setback Function

This feature, optionally available on some models, is designed to provide energy savings in applications where the process is idled at regular intervals through the connection of an external timer or switch.

CONTROL VALVES

TR890 Series

Electronic PID Controllers • Features PID & Auto-tuning



Multiple Sizes

± 0.3% Accuracy

Keyboard Programmable

Reverse or Direct Acting

Manual Output Override

The **TR890 Series** Electronic PID Controller is designed for use on applications where large load changes are expected, or extreme accuracy and fast response times are needed. With full auto-tune capabilities and a large selection of available inputs, the TR890 Series is ideally suited for use with a Watson McDaniel Control Valve.

Use of a Watson McDaniel No. TA987 Air Filter/Regulator is recommended for filtering and regulating the pressure of plant compressed air, and for delivering clean, dry air at the proper pressure to pneumatic control devices.

Approximate Shipping Weights:

TR891: 0.4 lbs [0.17 kg]
 TR892: 0.6 lbs [0.28 kg]
 TR893: 0.7 lbs [0.33 kg]
 TR894: 0.5 lbs [0.24 kg]

Specifications

Models	TR891: 48 x 48 mm (1/16 DIN) TR892: 72 x 72 mm TR893: 96 x 96 mm (1/4 DIN) TR894: 96 x 48 mm (1/8 DIN)
Control	Control Mode: Auto-Tuning PID Action: Reverse acting (field switchable to direct acting)
Proportional Band	Off, 0.1-999.9% Full Scale Integral Time: Off, 1-6000 sec. Derivative Time: Off, 1-3600 sec.
Accuracy	± 0.3%
Display	Process Value: 4 Digit, 20 mm red LED Set Value: 4 digit, 10.2 mm green LED Sampling Cycle: 0.25 seconds
Inputs	Multi: (switchable between) ▶ Thermocouple: B, R, S, K, E, J, T, N, PL II, WRe5-26 (U,L (DIN 43710) ▶ RTD: Platinum 100 Ω, 3-Wire ▶ mV: (scalable) -10-10, 0-10, 0-20, 0-50, 10-50, 0-100 mV DC Current: (scalable) 4-20, 0-20 mA Voltage: -1-1, 0-1, 0-2, 0-5, 1-5, 0-10 VDC
Control Output	Current: 4-20 mA (load resistance: 600 Ω maximum) Contact: Proportional cycle, 1-120 sec. (capacity: 240 VAC 2 A resistive / 1.2 A inductive) SSR Drive Voltage: Proportional cycle 1-120 sec. (output rating: 12 ± 1.5 VDC / 30 mA maximum) Voltage: 0-10 VDC Load Current 2 mA max
Power Requirements	Supply Voltage: 100-240 VAC, 50/60 Hz or 24 VAC/VDC 50/60 Hz Consumption: 100-240 VAC, 15VA 24 VDC, 8W 24 VAC, 9VA
Data Storage	Nonvolatile EEPROM memory
Case Material	Polyphenylene Oxide (PPO)
Ambient Temp.	14°F (-10°C) to 122°F (50°C)
Humidity	Maximum: 90% RH, non-condensing
Event Outputs	(Contact Capacity: 240 VAC, 1 A/resistive load) Dual Event Outputs (High and/or Low Alarms) Single Event Output + Heater Break Alarm (includes CT30A sensor) Single Event Output + Heater Break Alarm (includes CT50A sensor)
Options:	Analog Output: 0-10 mV DC (output resistance 10 Ω) Analog Output: 4-20 mA DC (load resistance 300 Ω max) Analog Output: 0-10 VDC (load current 2 mA max) Digital Input (switch) including: Setback Function setting range of -1999 - 5000, standby or DA/RA Selection Operated by either non-voltage contact or open collector

CONTROL VALVES

TR890 Series

Electronic PID Controllers

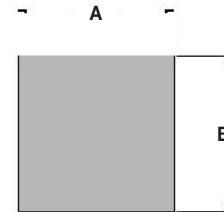
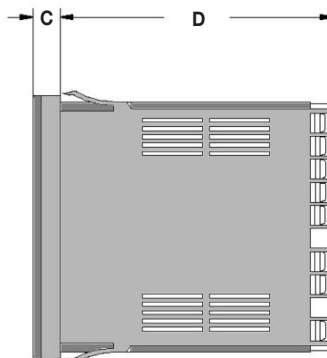
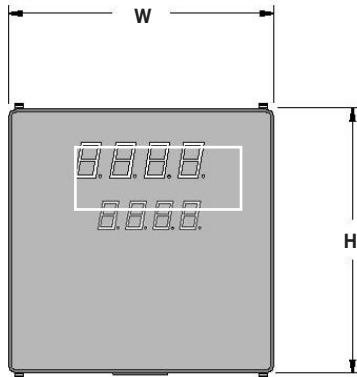

PANEL CUTOUT DIMENSIONS

HOW TO ORDER

Sample Order Number: **TR893 8 A C 90 1 00**

Model	Input	Control Output	Power Supply	Event Output	Options
TR891	8 Multi	A 4-20 mA	90 100-240 VAC, 50/60 Hz	0 None	00 None
TR892	4 mA	C On/Off Contact	08 24 VAC/VDC, 50/60 Hz	1 Dual Event (high and/or low)	30 Analog Output (0-10 mVDC)
TR893	6 VDC	D SSR Driver		2 Single Event (high or low) and heater break CT30A	40 Analog Output (4-20 mA)
TR894		E 0-10 VDC		3 Single Event (high or low) and heater break CT50A	60 Analog Output (0-10 VDC)

Event Outputs 2 or 3 require Control Outputs C or D

CONTROL VALVES

Electronic PID Controller Dimensions – units: inches [mm].

*Not available with Model TR891

Model	A	B	C	D	H	W
TR891	1.77 [45]	1.77 [45]	0.43 [11]	3.94 [100]	1.89 [48]	1.89 [48]
TR892	2.68 [68]	2.68 [68]	0.43 [11]	3.94 [100]	2.83 [72]	2.83 [72]
TR893	3.63 [92]	3.63 [92]	0.43 [11]	3.94 [100]	3.78 [96]	3.78 [96]
TR894	1.77 [45]	3.63 [92]	0.43 [11]	3.94 [100]	3.78 [96]	3.78 [96]

Programmable Ranges

Thermocouple Inputs				RTD Inputs				Current & Voltage Inputs	
T/C Type	Range Code	Fahrenheit Range	Celsius Range	Range Code	Fahrenheit Range	Range Code	Celsius Range	Range Code	Range (User-scalable Readout)
B*	15	0° to 3300°F	0° to 1800°C	47	-300° to 1100°F	31	-200° to 600°C	71	-10-10 mV
E	21	0° to 1300°F	0° to 700°C	48	-150.0° to 200.0°F	32	-100.0° to 100.0°C	72	0-10 mV
J	22	0° to 1100°F	0° to 600°C	49	-150° to 600°F	33	-100.0° to 300.0°C	73	0-20 mV
K	18	-150° to 750°F	-100.0° to 400.0°C	50	-50.0° to 120.0°F	34	-50.0° to 50.0°C	74	0-50 mV
K	19	0° to 1500°F	0° to 800°C	51	0.0° to 120.0°F	35	0.0° to 50.0°C	75	10-50 mV
K	20	0° to 2200°F	0° to 1200°C	52	0.0° to 200.0°F	36	0.0° to 100.0°C	76	0-100 mV
L	28	0° to 1100°F	0° to 600°C	53	0.0° to 400.0°F	37	0.0° to 200.0°C	81	-1-1 V
N	24	0° to 2300°F	0° to 1300°C	54	0° to 1000°F	38	0.0° to 500.0°C	82	0-1 V
PL II	25	0° to 2300°F	0° to 1300°C					83	0-2 V
R	16	0° to 3100°F	0° to 1700°C					84	0-5 V
S	17	0° to 3100°F	0° to 1700°C					85	1-5 V
T	23	-300° to 400°F	-199.9° to 200.0°C					86	0-10 V
U	24	-300° to 400°F	-199.9° to 200°C					94	0-20 mA
WRe5-26	26	0° to 4200°F	0° to 2300°C					95	4-20 mA

Range Codes are not required for ordering, but are used for field programming.

*750°F (400°C) falls below the accuracy range

CONTROL VALVES

TA901 Series

I/P Transducer • Electropneumatic



- ▶ 4 to 20 mA Input
- ▶ 3 to 15 PSI Output
- ▶ Intrinsically Safe
- ▶ Zero and Span Adjustments

The **TA901 Electropneumatic (I/P) Transducer** converts a milliamp current signal to a linearly proportional pneumatic output pressure. This transducer is designed for control applications that require a high degree of reliability and repeatability. The TA901 is used in the control operation of valve actuators and pneumatic valve positioners in the petrochemical, HVAC, energy management, textile, paper, and food & drug industries.

The TA901 I/P Transducer is tested and approved by Factory Mutual as Intrinsic Safe Class I, II and III, Division I, Groups C, D, E, F and G when installed in accordance with the Installation, Operation and Maintenance Instructions. It should be installed in a vertical position in a vibration-free area.

The Watson McDaniel TA987 Air Filter/Regulator is recommended for filtering and regulating the pressure of plant compressed air, and for delivering clean, dry air at the proper pressure to pneumatic control devices.

Specifications

<p>Model TA901</p> <p>Input 4-20 mA</p> <p>Output 1-17 PSIG Per ANSI/FCI 87-2 (can be calibrated to provide 1-9 PSIG or 9-17 PSIG)</p> <p>Volume Booster Built-in volume booster allows flow capacity up to 20 SCFM</p> <p>Connections Pneumatic: 1/4" NPT Electric: 1/2" NPT</p>	<p>Air Requirements Clean, oil-free, dry air filtered to 40 microns</p> <p>Minimum Supply Pressure: 3 PSIG</p> <p>Maximum Supply Pressure: 100 PSIG</p> <p>Sensitivity: < ±0.1% of span per PSIG</p> <p>Air Consumption: 0.03 SCFH typical</p> <p>Flow Rate: 4.5 SCFM at 25 PSIG supply</p> <p>Relief Capacity: 2.0 SCFM at 5 PSIG above 20 PSIG setpoint</p>	<p>Mounting Pipe, panel or bracket in a vibration-free area. Field adjustment will be required if mounted in a nonvertical position.</p> <p>Adjustment Adjustable zero and span</p> <p>Accuracy Terminal Based Linearity: < ±0.75% of span Repeatability: < 0.5% of span Hysteresis: < 1.0% of span Response Time: < 0.25 sec. @ 3-15 PSIG</p>	<p>Intrinsic Safety Tested and approved by Factory Mutual as Intrinsically Safe Class I, II and III, Division I, Groups C, D, E, F and G when installed in accordance with Installation, Operation and Maintenance Instructions</p> <p>Ambient Temperature -20°F (-30°C) to 140°F (60°C)</p> <p>Approximate Shipping Weight 2.1 lbs [0.94 kg]</p>
--	---	---	--

CONTROL VALVES

HOW TO ORDER

Please order using Item Number: **TA901**

Unit: inches [mm].

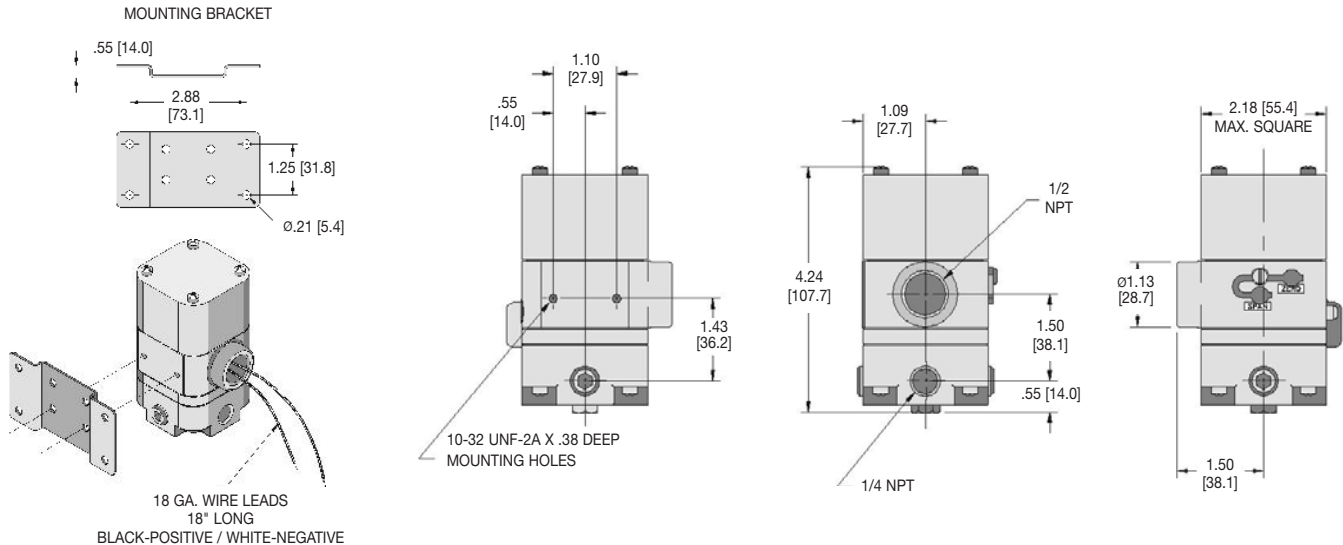

CONTROL VALVES

TA987

Air Filter/Regulator



- ▶ **Cast Aluminum Housing**
- ▶ **Removable Nylon Mesh Filter**
- ▶ **Low Air Consumption**
- ▶ **Drip Well**

The **TA987 Air Filter/Regulator** is recommended for filtering and regulating the pressure of plant compressed air, and for delivering clean, dry air at the proper pressure to pneumatic control devices. Supply air enters the inlet port, passes through the filtering element, and exits through the reducing valve to the outlet port. The filtering element removes particles as small as 40 microns. A drip well is provided for the accumulation of oil and water and a drain cock is included to allow purging of the unit. The filtering element is readily accessible for cleaning by removal of the drip well bowl.

The maximum allowable supply pressure to TA987 Air Filter/Regulator is 250 PSIG. Improper application may cause failure of the regulator, resulting in possible personal injury or property damage.

Specifications

Model TA987	Air Requirements (cont.) Flow Rate: 20 SCFM at 100 PSIG supply/20 PSIG output Relief Capacity: 0.1 SCFM at 5 PSIG above setpoint Effect of Supply Pressure Variation: < 0.2 PSIG for 25 PSIG	Filter Removes particles 40 microns or greater Port Size 1/4" NPT Housing Cast aluminum	Mounting Side, pipe, panel or through body Ambient Temperature -20°F (-30°C) to 160°F (71°C) Approximate Shipping Weight 1.9 lbs [0.86 kg]
Air Requirements Maximum Supply Pressure: 250 PSIG Output Range: 0 to 30 PSIG, adjustable Sensitivity: 0.036 PSIG Air Consumption: < 6 SCFH			

CONTROL VALVES

Units: inches [mm].

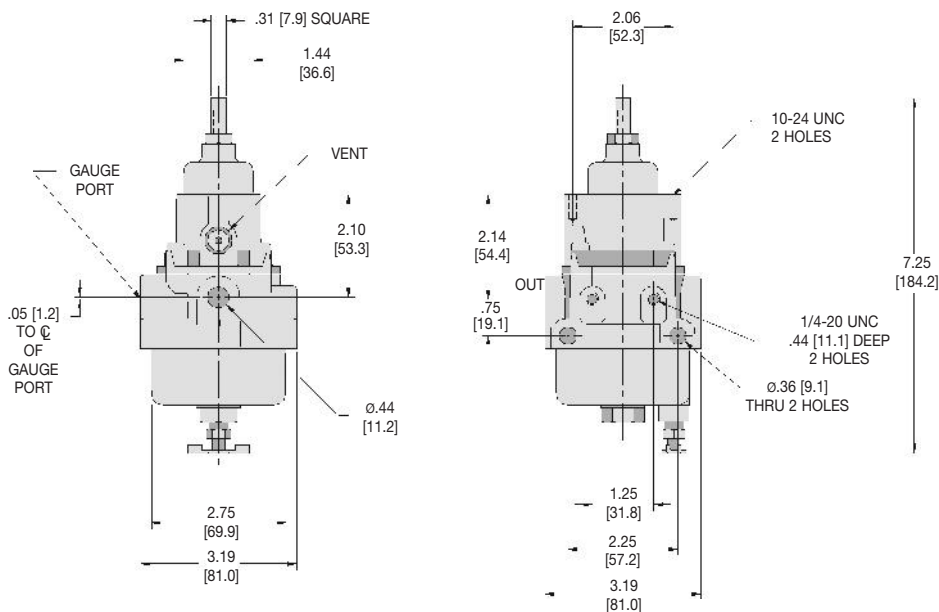

CONTROL VALVES

Electronic Temperature Sensors

Connection Head Type • RTD & Thermocouple



- ▶ Thermocouple or RTD
- ▶ Cast Aluminum, Polypropylene or Stainless Steel Head
- ▶ Weather Proof
- ▶ Welded or Spring Loaded Stem

The Watson McDaniel **Connection Head** is available with both Type J and Type K Thermocouples, as well as RTD sensors. The weather proof head provides a conduit connection and is available in cast aluminum (screw cover), polypropylene (flip cover) and stainless steel (screw cover). The stem is either welded directly to the 1/2" NPT threaded connection, or is spring-loaded to provide maximum sensitivity. The spring-loaded stem must always be installed in a thermowell.

Extension wire and transmitter accessories are also available. Please consult factory.

For applications where the process media may be corrosive or contained under pressure, the use of a thermowell is required to prevent damage to the sensor and facilitate its removal from the process. To prevent leakage of the process media, spring loaded sensors must always be installed in a thermowell.

Specifications

Sensors	Description
TJD	Type J T/C
TKD	Type K T/C
TDD	100 Ω RTD
TMD	1000 Ω RTD
Hot Junction	
	T/C: Ungrounded RTD: Platinum, 3-Wire
Stem	316 stainless steel 1/4" diameter
Insulation	Ceramic
Head	Cast aluminum, polypropylene or stainless steel
Process Connection	
	1/2" NPT welded or spring-loaded
Conduit Connection	
	3/4" NPT Female
Approximate Shipping Weight	
	1.1 lbs [0.50 kg]

CONTROL VALVES

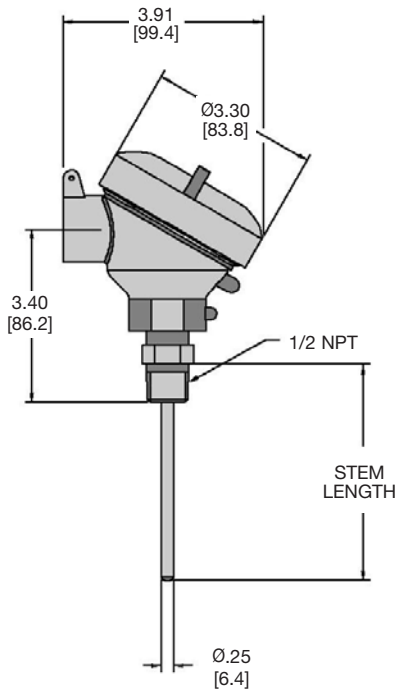

Units: inches [mm]

Sensor Specifications

Thermocouple

Type	Color Code	Positive Lead	Negative Lead	Temperature Range
J	Black	Iron* (Fe) [white]	Constantan (Cu-Ni) [red]	32° to 1382°F (0° to 750°C)
K	Yellow	Nickel-Chromium (Ni-Cr) [yellow]	Nickel-Aluminum* (Ni-Al) [red]	32° to 2282°F (0° to 1250°C)

*magnetic lead

RTD

Type	Material	Resistance @ 0°C	Temperature Coefficient	Temperature Range
D	Platinum (Pt)	100 Ω	α = 0.00385 Ω/Ω/°C	-50° to 700°F (-45° to 400°C)
M	Platinum (Pt)	1000 Ω	α = 0.00385 Ω/Ω/°C	-50° to 700°F (-45° to 400°C)

HOW TO ORDER

Sample Order Number: **TJD Z 04 U W A**

Sensor	Stem Style	Stem Length	Hot Junction	Connection	Head Material
TJD Type J T/C	Z 316SS, 1/4" O.D.	02 2 1/2" Stem	U Ungrounded (T/C)	S Spring Loaded, 1/2" NPT	A Aluminum
TKD Type K T/C		04 4" Stem	D 3-Wire (RTD)	W Welded, 1/2" NPT	P Polypropylene
TDD 100 Ω RTD		06 6" Stem			S Stainless Steel
TMD 1000 Ω RTD		09 9" Stem			
		12 12" Stem			

Other sensor styles available. Please consult factory.

Other Lengths: Specify in inches (24" maximum)

Thermowells

for RTD & Thermocouple Temperature Sensors

Standard (2 1/2" - 6")

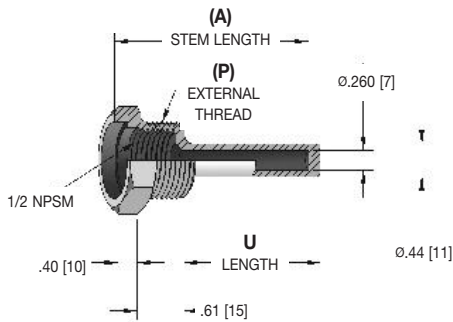

Standard (9" - 24")

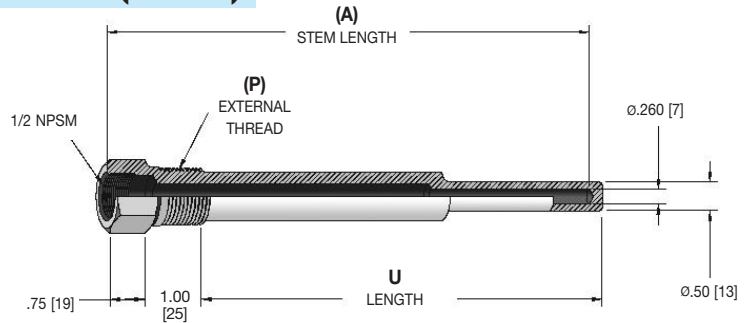

with Lagging Extension (4" - 24")

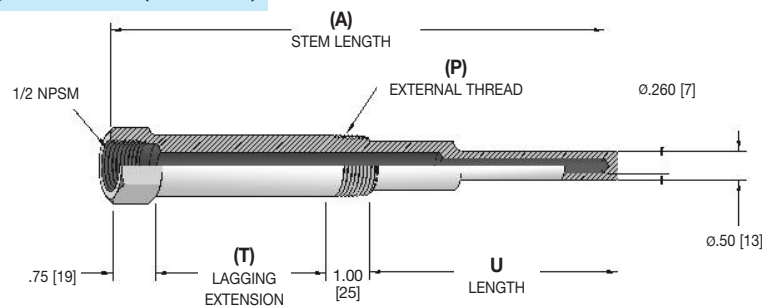

Units inches: [mm]

Lengths

(A) Stem Length	Standard U Length	Lagging (T) Lagging Extension	U Length
2 1/2"	1.75 [44]	—	—
4"	2.50 [64]	1.00 [25]	1.50 [38]
6"	4.50 [114]	2.00 [51]	2.50 [64]
9"	7.50 [191]	3.00 [76]	4.50 [114]
12"	10.50 [267]	3.00 [76]	7.50 [191]
15"	13.50 [343]	3.00 [76]	10.50 [267]
18"	16.50 [419]	3.00 [76]	13.50 [343]
24"	22.50 [572]	3.00 [76]	19.50 [495]

Pressure Ratings (PSI)

Material	Operating Temperature					
	70°F	200°F	400°F	600°F	800°F	1000°F
Carbon steel	5000	5000	4800	4600	3500	-
304 stainless steel	6550	6000	4860	4140	3510	3130
316 stainless steel	6540	6400	6000	5270	5180	4660
Monel	5530	4990	4660	4450	4450	-
Brass	3170 PSI @ 150°F, 2930 PSI @ 350°F					

Selection of the proper thermowell is the sole responsibility of the user. Temperature and pressure limitations must be considered. Improper application may cause failure of the thermowell, resulting in possible personal injury or property damage. For correct use and application, please refer to the Thermowells For Thermometers And Electrical Temperature Sensors Standard ASME B40.9.

HOW TO ORDER

Sample Order Number: **76-4J6**

Thermowell Style	(P) External Thread	(A) Stem Length	(T) Lagging Extension	Material
76 -Sensor, Stepped Shank (2 1/2" - 6" Stem Straight Shank)	3 1/2 NPT*	D 2 1/2" Stem	A 1" Extension (4" Stem only)	2 Brass
	4 3/4 NPT	G 4" Stem	C 2" Extension (6" Stem only)	3 Steel
	5 1 NPT*	J 6" Stem	E 3" Extension (9" thru 24" Stem only)	4 Monel
		M 9" Stem	Omit if No Extension	5 304SS
		R 12" Stem		6 316SS
		V 15" Stem		
		Wa 18" Stem		
		Wk 24" Stem		

*Not available with 2 1/2" Stem Length

Other thermowell styles available. Please consult factory.

Liquid Drainers



LIQUID
DRAINERS

Liquid Drainers

Model/Series	Type	Body Material	PMO (PSIG)	Sizes	Connection	Page No.
WLDE WLDES	Float Float	Ductile Iron Cast Steel	200 300	1 1/2", 2", 2 1/2" 2 1/2"	NPT NPT, SW, FLG	208-209
WLD600 WLD601	Float Float	Carbon Steel 316 Stainless Steel	450	3/4" – 4"	NPT, SW, FLG	210-211
WLD1400	Float	Ductile Iron	300	1/2" – 2"	NPT	212-213
WLD1500	Inverted Bucket	Cast Iron	200	3/4", 1"	NPT	214-215
WLD1703S	Thermodynamic	Stainless Steel	250	1/2"	NPT	216
WLD1800/1800R	Guided Float	Stainless Steel	400	1/2", 3/4"	NPT	217-218
WLD1900	Float	Cast Iron	250	3/4" – 2"	NPT	219-221
Installation Guidelines for Liquid Drain Traps						222-223

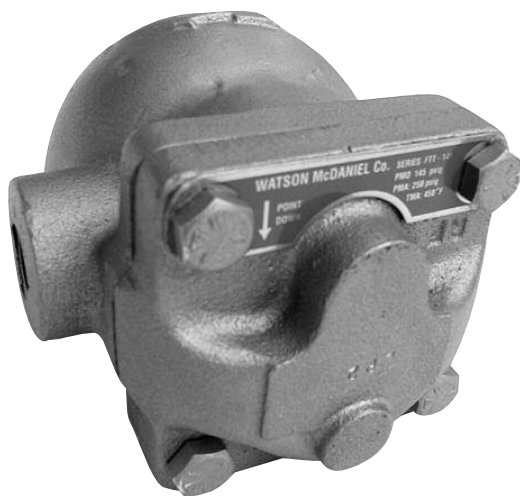

LIQUID
DRAINERS



LIQUID DRAINERS

WLDE/WLDES Series

Float Type Liquid Drain Trap

Watson McDaniel reserves the right to change the designs and/or materials of its products without notice.
©2010 Watson McDaniel Company

Model	WLDE	WLDES
Sizes	1 1/2", 2", 2 1/2"	2 1/2"
Connections	NPT	NPT, SW, Flanged
Body Material	Ductile Iron	Cast Steel
PMO Max. Operating Pressure	200 PSIG	300 PSIG
TMO Max. Operating Temperature	450°F	450°F
PMA Max. Allowable Pressure	300 PSIG up to 450°F	300 PSIG up to 750°F
TMA Max. Allowable Temperature	450°F @ 300 PSIG	750°F @ 300 PSIG



TYPICAL APPLICATIONS

The **WLDE/WLDES Series** high-capacity condensate drainers meet the flow requirements that are typically found in heavy industrial process applications for air and other gases.

HOW IT WORKS

This liquid drainer has a float-operated valve that gives the trap a modulating flow characteristic. The amount of liquid flowing into the drainer is sensed by the float which positions the main valve to discharge the liquid at the same rate as it is received.

FEATURES

- Ductile Iron or Cast Steel body and cover
- All stainless steel internals for long service life
- High capacity liquid removal
- Rugged construction design for heavy industrial use
- In-line repairable

SAMPLE SPECIFICATION

The liquid drain trap shall be float operated with a ductile iron or cast steel body and all stainless steel internals. The unit shall be in-line repairable and equipped with a FNPT threaded connection for the use of a balance line.

INSTALLATION

The installation should include isolation valves to facilitate maintenance and an in-line strainer. The trap must be level and upright for the float mechanism to operate. The 2" and 2 1/2" traps should not be supported by the piping alone. Trap must be sized and properly located in the system. Piping hook-up must include an equalizing line.

MAINTENANCE

Close isolation valves prior to any maintenance. All working components can be replaced with the drain trap remaining in the pipeline. Repair kits include float, valve seat & disc, and gaskets. For full maintenance details see Installation and Maintenance Manual.

MATERIALS

Body & Cover	WLDE - Ductile Iron WLDES - Cast Steel
Cover Screw	Carbon Steel, Gr 5
Cover Gasket	Garlock
Valve Discs	Stainless Steel, AISI 303
Main Valve Assembly Housing	Stainless Steel, AISI 304
Valve Assembly Gasket	Garlock
Ball Float	Stainless Steel, AISI 304
All other components	Stainless Steel

LIQUID DRAINERS

WLDE/WLDES Series

Float Type Liquid Drain Trap

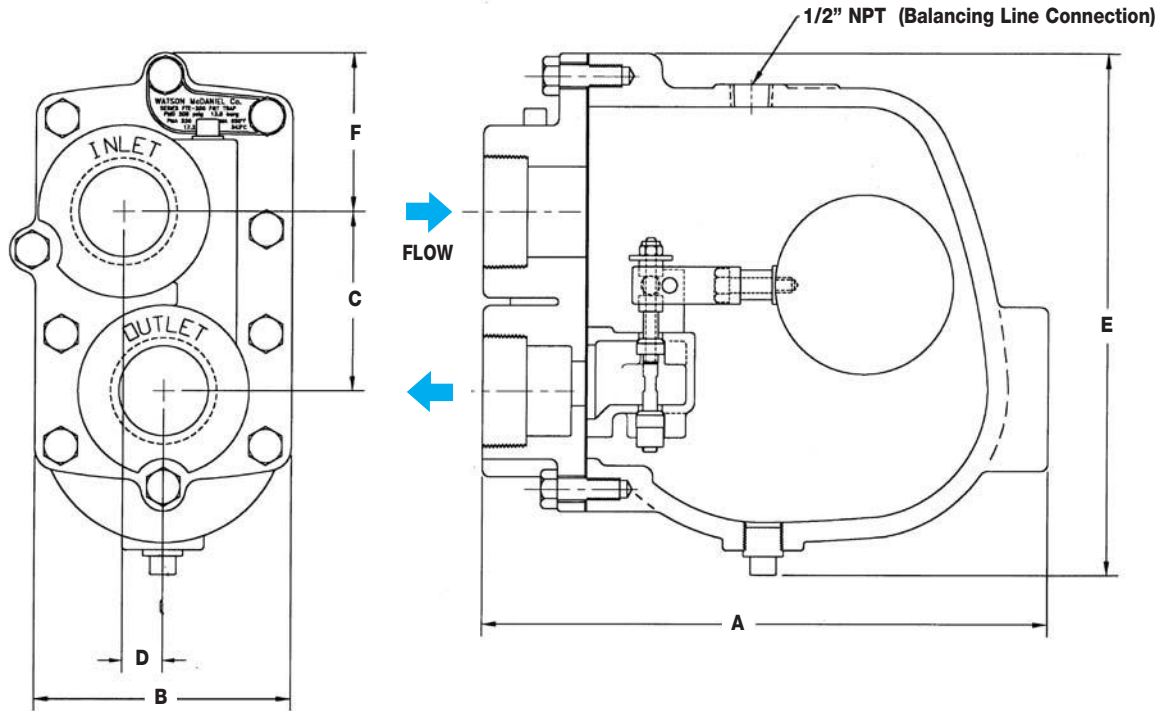

DIMENSIONS & WEIGHTS — inches / pounds								
Model-PMO Size (PSIG)	A	B	C	D	E	F	Weight (lbs)	
WLDE-20 2"	12 ¹ / ₈	5 ¹ / ₁₆	4 ¹ / ₂	1/2	11 ¹ / ₈	3 ¹⁵ / ₁₆	44	
WLDE-50 2"	16	8 ⁷ / ₁₆	7 ⁵ / ₁₆	1 ⁷ / ₁₆	15 ¹ / ₈	3 ¹ / ₈	91	
WLDE-50 2 ¹ / ₂ "	15 ¹ / ₂	8 ⁷ / ₁₆	7 ⁵ / ₁₆	1 ⁷ / ₁₆	15 ¹ / ₈	3 ¹ / ₈	91	
WLDE-125 2 ¹ / ₂ "	15 ¹ / ₂	8 ⁷ / ₁₆	7 ⁵ / ₁₆	1 ⁷ / ₁₆	15 ¹ / ₈	3 ¹ / ₈	92	
WLDE-200 1 ¹ / ₂ "	9 ¹ / ₈	4 ⁵ / ₁₆	3	1 ¹ / ₁₆	8 ¹³ / ₁₆	2 ¹ / ₈	23	
WLDE-200 2"	12 ¹ / ₈	5 ¹ / ₁₆	4 ¹ / ₂	1/2	11 ¹ / ₈	3 ¹⁵ / ₁₆	50	
WLDE-200 2 ¹ / ₂ "	15 ¹ / ₂	8 ⁷ / ₁₆	7 ⁵ / ₁₆	1 ⁷ / ₁₆	15 ¹ / ₈	3 ¹ / ₈	92	
WLDES-300 2 ¹ / ₂ "	15 ¹ / ₂	8 ⁷ / ₁₆	7 ⁵ / ₁₆	1 ⁷ / ₁₆	15 ¹ / ₈	3 ¹ / ₈	92	

HOW TO SIZE/ORDER

Determine differential pressure and capacity (lbs/hr) required. Locate differential pressure on capacity chart; move down column to capacity required. Make sure to select the correct model based on the required inlet pressure. Example:

Application: 80,000 lbs/hr at 100 PSIG working pressure and 5 PSI differential pressure
 Size/Model: 2¹/₂" WLDE-125 @ 87,294 lbs/hr

LIQUID DRAINERS

CAPACITIES — Cold Water (lbs/hr)																	
Model-PMO (PSIG)	Size	Orifice Size	Differential Pressure (PSI)														
			1/4	1/2	1	2	5	10	15	20	40	50	75	100	125	150	200
WLDE-20	2"	.937"	3929	5556	7858	11113	17571	24849	30433	35141							
WLDE-50	2"	2.125"	12248	18153	25312	37751	62218	90068	106565	123365	161302	176522					
WLDE-50	2 ¹ / ₂ "	2.125"	19520	27605	39039	55209	87294	123452	151197	174588	246904	276047					
WLDE-125	2 ¹ / ₂ "	2.125"	19520	27605	39039	55209	87294	123452	151197	174588	246904	276047	338088	390390	436469		
WLDE-200	1 ¹ / ₂ "	.375"	1051	1486	2102	2973	4700	6647	8141	9401	13295	14864	18205	21021	23502	25745	29728
WLDE-200	2"	.75"	3403	4813	6807	9626	15220	21525	26363	30441	43050	48131	58949	68068	76102	83366	96263
WLDE-200	2 ¹ / ₂ "	1.5"	11100	15713	22200	31427	49690	70273	86066	99381	140546	157135	192450	222200	248452	272165	314269
WLDES-300	2 ¹ / ₂ "	1.5"	11100	15713	22200	31427	49690	70273	86066	99381	140546	157135	192450	222200	248452	272165	314269

Note: Capacity for 250 PSI Differential Pressure = 365,232 lbs/hr; for 300 PSI Differential Pressure = 427,024 lbs/hr (for WLDES-300 only).

LIQUID DRAINERS

WLD600/601 Series

Float Type Liquid Drain Trap

Watson McDaniel reserves the right to change the designs and/or materials of its products without notice.
©2010 Watson McDaniel Company

Model	WLD600 / WLD601
Sizes	3/4", 1", 1 1/2", 2", 3", 4"
Connections	NPT, SW, Flanged
Body Material WLD600	Carbon Steel
Body Material WLD601	316 Stainless Steel
PMO Max. Operating Pressure	450 PSIG
TMO Max. Operating Temperature	750°F
PMA Max. Allowable Pressure	*990 PSIG @ 100°F
TMA Max. Allowable Temperature	*750°F @ 670 PSIG

* 3/4"- 2" only.

Note: For dimensions and capacities of 3" & 4" liquid drain traps, refer to model FT600 in the Steam Trap section.



TYPICAL APPLICATIONS

The **WLD600/WLD601 Series** are used in applications where immediate and continuous discharge of large amounts of liquid is required. Typically used in heavy industrial process applications for draining condensate from air or other gases.

HOW IT WORKS

This liquid drainer has a float-operated valve that gives the trap a modulating flow characteristic. The amount of liquid flowing into the drainer is sensed by the float which positions the main valve to discharge the liquid at the same rate as it is received.

FEATURES

- All stainless steel internals for long service life
- Body & cover available in Carbon Steel or 316 SS
- Rugged construction designed for heavy industrial applications
- In-line repairable

SAMPLE SPECIFICATION

The liquid drain trap shall be float operated with a cast steel body (or stainless steel body for WLD601) and all stainless steel internals. The unit shall be in-line repairable and equipped with a FNPT threaded connection for the use of a balance line.

INSTALLATION

The installation should include isolation valves to facilitate maintenance and an in-line strainer. The trap must be level and upright for the float mechanism to operate. The 2"– 4" traps should not be supported by the piping alone. Trap must be sized and properly located in the system. Piping hook-up must include an equalizing line.

MAINTENANCE

Close isolation valves prior to any maintenance. All working components can be replaced with the drain trap remaining in the pipeline. Repair kits include float, valve seat & disc and gaskets. For full maintenance details see Installation and Maintenance Manual.

OPTIONS

316 SS Body & Cover: use Model WLD601.

MATERIALS

Body & Cover WLD600	Cast Steel, ASTM A-216 WCB
Body & Cover WLD601	Cast 316 SS
Cover Studs	Steel, SA 193, Gr B7
Cover Nuts	Steel, SA 194, Gr 2H
Cover Gasket	Stainless Steel Reinforced Grafoil
Valve Assembly	Stainless Steel, AISI 431
Gasket, Valve Assembly	Stainless Steel Reinforced Grafoil
Pivot Assembly	Stainless Steel, 17-4 PH
Mounting Screws	Stainless Steel Hex Head, 18-8
Float	Stainless Steel, ASTM 240 TY 304

HOW TO SIZE/ORDER

Determine differential pressure and capacity (lbs/hr) required. Locate differential pressure on capacity chart; move down column to capacity required. Make sure to select the correct model based on the required inlet pressure. Example:

Application: 2,000 lbs/hr at 325 PSIG working pressure and 250 PSI differential pressure

Size/Model: 1" **WLD600-450** @ 2,060 lbs/hr

LIQUID DRAINERS

WLD600/601 Series

Float Type Liquid Drain Trap

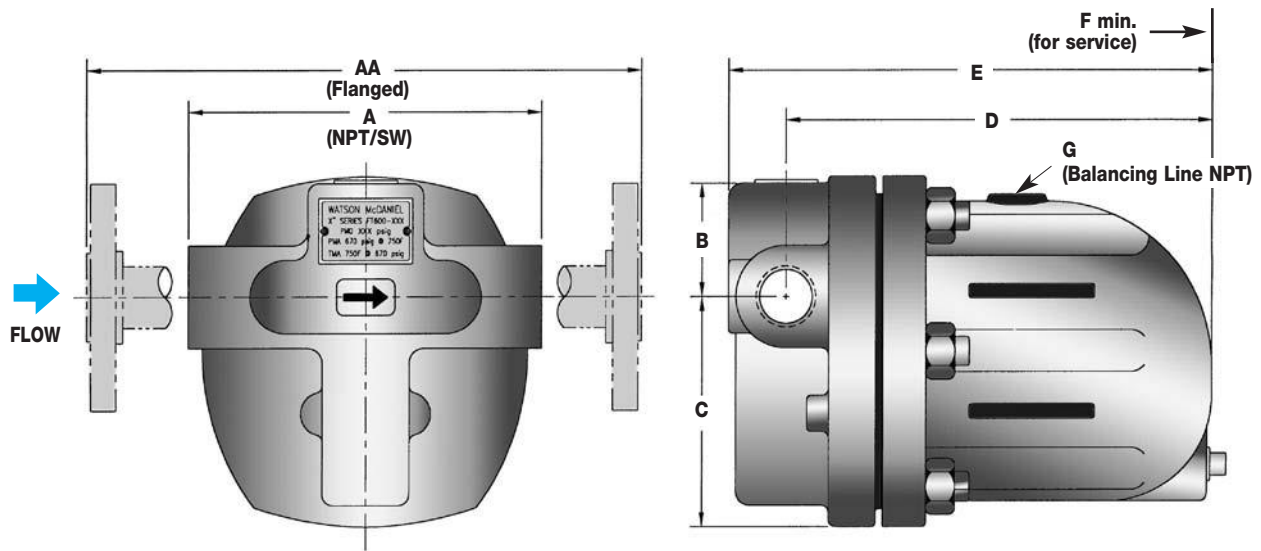

DIMENSIONS & WEIGHTS — inches / pounds

Size	A	AA	B	C	D	E	F	G *	Weight (lbs)	
									NPT/SW	FLG
3/4"	6 1/8	10 1/8	2 1/8	37/16	77/16	87/16	5 13/16	3/8	25	31
1"	6 1/2	10 7/16	2 1/2	5 1/2	87/16	9 1/2	6 5/16	3/8	31	36
1 1/2"	9 13/16	14	37/16	9	107/16	11 15/16	7 13/16	1/2	82	91
2"	11 13/16	16	3 1/8	77/16	11 1/8	13 5/16	6 13/16	1/2	93	107

* Balancing Port available with 1/2" flanged connection. Specify on order.

CAPACITIES — Cold Water (lbs/hr)

PMO	Size (in.)	Orifice (in.)	Differential Pressure (PSI)																	
			2	5	10	20	30	40	50	65	70	80	100	145	200	250	300	350	450	
65	3/4"	.156	340	520	730	1010	1220	1440	1560	1770										
65	1"	.276	1390	2140	2970	4130	5000	5730	6370	7210										
65	1 1/2"	.689	4160	6430	8920	12380	15000	17190	19110	21630										
65	2"	1.122	14730	22720	31540	43790	53060	60790	67570	76500										
145	3/4"	.126	210	320	450	620	760	870	960	1090	1130	1200	1340	1590						
145	1"	.205	690	1070	1490	2060	2500	2870	3190	3610	3740	3980	4420	5270						
145	1 1/2"	.591	2360	3630	5050	7010	8490	9730	10810	12240	12670	13500	15000	17890						
145	2"	.807	5840	9010	12510	17370	21040	24110	26800	30340	31420	33470	37200	44360						
200	3/4"	.106	170	260	360	500	600	690	770	870	900	960	1060	1270	1480					
200	1"	.185	450	690	960	1330	1620	1850	2060	2330	2410	2570	2860	3410	3970					
200	1 1/2"	.531	1650	2550	3540	4910	5950	6820	7580	8580	8890	9470	10520	12540	14610					
200	2"	.657	2890	4460	6190	8590	10410	11930	13250	15010	15540	16560	18400	21940	25540					
300	3/4"	.079	80	130	180	250	300	340	380	430	450	480	530	630	730	820	890			
300	1"	.156	340	520	730	1010	1220	1400	1560	1770	1830	1950	2160	2580	3010	3340	3640			
300	1 1/2"	.531	1650	2550	3540	4910	5950	6820	7580	8580	8890	9470	10520	12540	14610	16230	17700			
300	2"	.657	2890	4460	6190	8590	10410	11930	13250	15010	15540	16560	18400	21940	25540	28930	30950			
450	3/4"	.063	50	70	100	140	160	190	210	240	250	260	290	350	400	450	490	530	590	
450	1"	.126	210	320	450	620	760	870	960	1090	1130	1200	1340	1590	1860	2060	2250	2420	2720	
450	1 1/2"	.531	1650	2550	3540	4910	5950	6820	7580	8580	8890	9470	10520	12540	14610	16230	17700	19040	21440	
450	2"	.657	2890	4460	6190	8590	10410	11930	13250	15010	15540	16560	18400	21940	25540	28390	30950	33290	37490	

LIQUID DRAINERS

LIQUID DRAINERS

WLD1400 Series

Float Type Liquid Drain Trap

Watson McDaniel reserves the right to change the designs and/or materials of its products without notice.
©2010 Watson McDaniel Company

Model	WLD1400
Sizes	1/2", 3/4", 1", 1 1/2", 2"
Connections	NPT
Body Material	Ductile Iron
PMO Max. Operating Pressure	300 PSIG
TMO Max. Operating Temperature	450°F
PMA Max. Allowable Pressure	300 PSIG up to 450°F
TMA Max. Allowable Temperature	450°F @ 300 PSIG

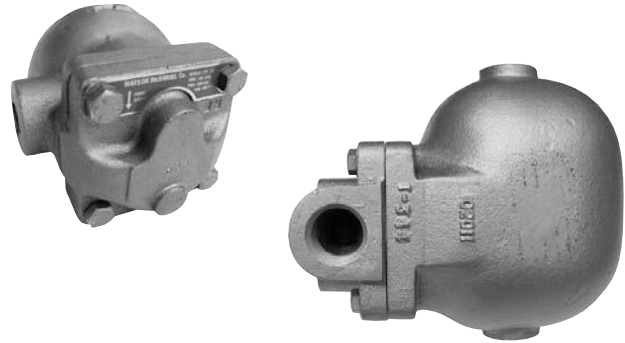

TYPICAL APPLICATIONS

The **WLD1400 Series** is used on air and gas applications as drip traps on piping runs as well as drainage for systems and various process vessels that have moderate condensate loads.

HOW IT WORKS

This liquid drainer has a float-operated valve that gives the trap a modulating flow characteristic. The amount of liquid flowing into the drainer is sensed by the float which positions the main valve to discharge the liquid at the same rate as it is received.

FEATURES

- All stainless steel internals
- Hardened valve seat for longer service life
- Ductile Iron body
- In-line repairable

SAMPLE SPECIFICATION

The liquid drain trap shall be float operated with a ductile iron body, all stainless steel internals and a hardened valve seat. The unit shall be in-line repairable and equipped with a FNPT threaded connection for the use of a balance line.

INSTALLATION

The installation should include isolation valves to facilitate maintenance and an in-line strainer. The trap must be level and upright for the float mechanism to operate. Trap must be sized and properly located in the system. Piping hook-up must include an equalizing line for drainers 1" and larger.

MAINTENANCE

Close isolation valves prior to any maintenance. All working components can be replaced with the drain trap remaining in the pipeline. Repair kits include float, valve seat & disc, and gaskets. For full maintenance details see Installation and Maintenance Manual.

HOW TO SIZE/ORDER

Determine differential pressure and capacity (lbs/hr) required. Locate differential pressure on capacity chart; move down column to capacity required. Make sure to select the correct model based on the required inlet pressure. Example:

Application: 3,500 lbs/hr at 15 PSIG working pressure and 2 PSI differential pressure

Size/Model: 1 1/2" **WLD1416-065** @ 4,300 lbs/hr

LIQUID DRAINERS

WLD1400 Series

Float Type Liquid Drain Trap

WLD1400 1/2" & 3/4"

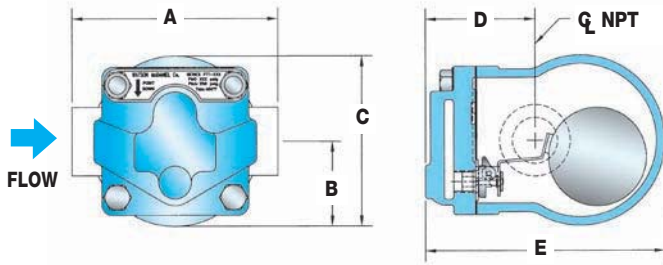

WLD1400 1"

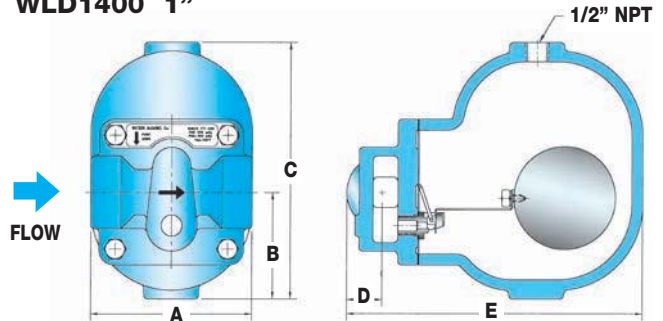

WLD1400 1 1/2" & 2"

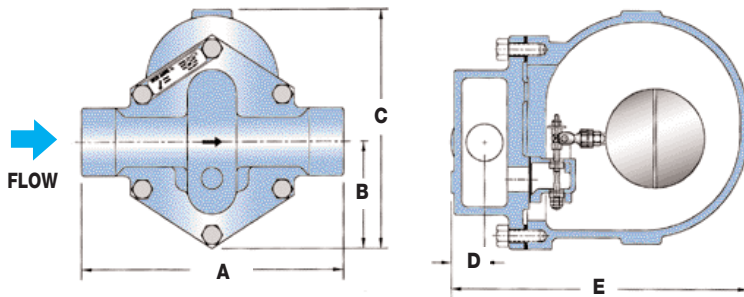

DIMENSIONS & WEIGHTS – inches/pounds

Size	A	B	C	D	E	Weight
1/2", 3/4"	4.8	1.9	3.9	2.5	5.5	6
1"	4.8	3.1	7.5	1.1	8.8	16
1 1/2"	10.6	4.3	9.6	1.4	12	40
2"	11.9	4.3	9.6	1.4	12	40

MATERIALS

Body & Cover	Ductile Iron
Gasket	Garlock 3400
Cover Screws	Stainless Steel, Gr 5
Float	Stainless Steel, AISI 304
Internals	Stainless Steel, 300 Series
Valve Seat	Stainless Steel, 17-4 PH
Valve Disc	Stainless Steel, AISI 420F

CAPACITIES – Cold Water (lbs/hr)

Model	Size	PMO (PSIG)	Orifice Size	Differential Pressure (PSI)																		
				1	2	5	10	15	20	30	40	50	65	75	100	125	145	200	225	300		
WLD1412-065	1/2"	65	.157"	250	340	530	730	880	1010	1230	1410	1560	1770									
WLD1413-065	3/4"	65	.157"	250	340	530	730	880	1010	1230	1410	1560	1770									
WLD1414-065	1"	65	.273"	980	1360	2090	2910	3520	4040	4890	5600	6220	7050									
WLD1416-065	1 1/2"	65	.157"	3125	4300	6600	9350	11225	13250	16350	18700	20950	23500									
WLD1417-065	2"	65	.273"	10600	14900	23300	31500	38150	44750	53600	61850	69200	76375									
WLD1412-145	1/2"	145	.100"	110	150	230	320	380	440	530	610	680	770	940	1050	1130	1200					
WLD1413-145	3/4"	145	.100"	110	150	230	320	380	440	530	610	680	770	940	1050	1130	1200					
WLD1414-145	1"	145	.202"	490	670	1040	1440	1750	2000	2430	2780	3090	3500	4290	4760	5110	5350					
WLD1416-145	1 1/2"	145	.100"	1575	2175	3400	4650	5525	6325	7750	8950	9925	11000	12300	13975	15300	16500					
WLD1417-145	2"	145	.202"	3875	5450	8575	11500	12350	13200	20950	24050	27175	31050	34150	38500	42225	45950					
WLD1412-225	1/2"	225	.079"	60	80	130	180	220	250	300	340	380	430	530	590	630	690	740	780			
WLD1413-225	3/4"	225	.079"	60	80	130	180	220	250	300	340	380	430	530	590	630	690	740	780			
WLD1414-225	1"	225	.184"	320	450	690	960	1160	1330	1610	1850	2050	2330	2850	3170	3400	3710	3960	4100			
WLD1416-250	1 1/2"	250	.079"	1000	1375	2150	3050	3600	4100	5025	5775	6400	7300	8050	8900	9750	10550	12450	13150			
WLD1417-250	2"	250	.184"	1900	2675	4250	5850	7000	8225	10050	11595	12950	15125	16700	18300	20200	22100	25850	27100			
WLD1414-300	1"	300	.153"	230	320	500	690	840	960	1170	1340	1480	1680	2060	2290	2460	2680	2860	3020	3460		

LIQUID DRAINERS

WLD 1500 Series

Inverted Bucket Liquid Drain Trap

Watson McDaniel reserves the right to change the designs and/or materials of its products without notice.
©2010 Watson McDaniel Company

Model	WLD1501, WLD1502, WLD1504, WLD1521, WLD1522, WLD1524
Sizes	3/4", 1"
Connections	NPT
Body Material	Cast Iron
PMO Max. Operating Pressure	200 PSIG
TMO Max. Operating Temperature	450°F
PMA Max. Allowable Pressure	250 PSIG up to 450°F

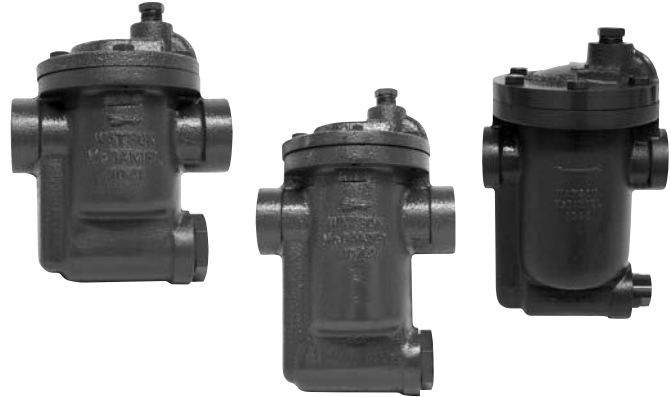

WLD1521/1522/1524
with Strainer

Note:

Trap should be ordered with an internal check valve or a separate check valve needs to be placed in-line during installation on the discharge side of the trap.

TYPICAL APPLICATIONS

The **WLD1500 Series** Inverted Bucket Liquid Drain Traps are recommended for the removal of oil and liquids from compressed air systems.

HOW IT WORKS

When there is condensate in the system, the inverted bucket inside the liquid drain trap sits on the bottom of the unit due to its weight. This allows condensate to enter the trap and to be discharged through the seat orifice located at the top. When air enters the trap, the bucket floats to the surface and closes off the discharge valve, containing the air in the system. Eventually, air is bled off through a small port in the top of the bucket and the bucket sinks, repeating the cycle.

FEATURES

- Hardened stainless steel valves and seat
- Only two moving parts
- Scrubber wire in air vent of bucket
- Discharge orifice at top, allowing for superior oil removal
- In-line repairable

SAMPLE SPECIFICATION

Drain trap shall be an inverted bucket trap design with cast iron body, all stainless steel internals, hardened valve & seat, plus a scrubber wire. The unit shall be in-line repairable.

INSTALLATION

Installation should include isolation valves for maintenance purposes and an in-line strainer. Trap must be installed in upright position to function properly. It may be necessary to prime the bucket trap by filling it with water through the priming port, prior to startup.

MAINTENANCE

Close isolation valves prior to any maintenance. All working components can be replaced with the drain trap remaining in the pipeline. Repair kits include lever & seat assembly, strainer screen and gaskets. For full maintenance details see Installation and Maintenance Manual.

MATERIALS

Body & Cover	Cast Iron, ASTM A-278 Class 30
Nuts & Bolts	High-Tensile Steel
Gasket	Non-Asbestos Fiber
Bucket	Stainless Steel
Scrubber	Stainless Steel
Lever & Seat Assembly	Stainless Steel
Valve & Seat	Hardened Stainless Steel
Integral Strainer*	Stainless Steel

* WLD1521, WLD1522 & WLD1524 models only.

LIQUID DRAINERS

WLD1500 Series

Inverted Bucket Liquid Drain Trap

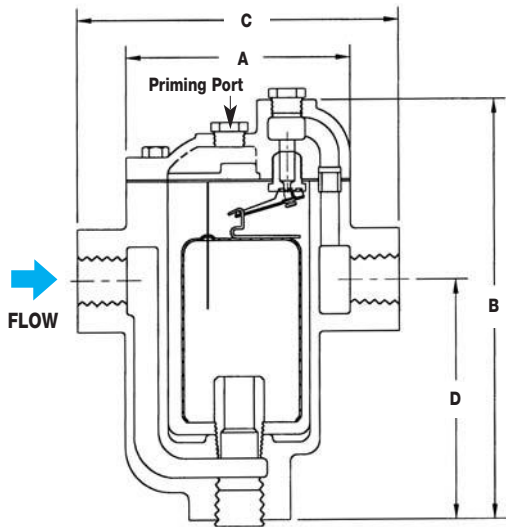

WLD1501/1502/1504

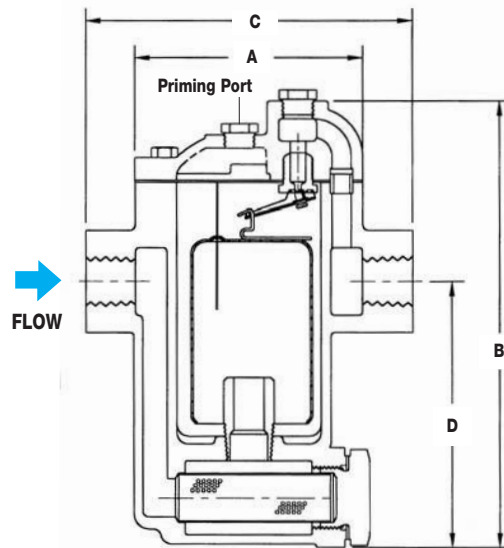

WLD1521/1522/1524
with Strainer

DIMENSIONS & WEIGHTS — inches / pounds

Model	Size	A	B	C	D	Weight
WLD1501	3/4"	3 ¹³ / ₁₆	5 ⁷ / ₁₆	5	2 ¹³ / ₁₆	5
WLD1502	3/4"	3 ¹³ / ₁₆	6 ¹⁵ / ₁₆	5	4 ⁵ / ₁₆	6
WLD1504	1"	7	11 ¹³ / ₁₆	7 ¹³ / ₁₆	7	27
WLD1521	3/4"	3 ¹³ / ₁₆	6 ¹ / ₈	5	3 ⁷ / ₁₆	5.5
WLD1522	3/4"	3 ¹³ / ₁₆	7 ¹ / ₈	5	4 ⁷ / ₁₆	6
WLD1524	1"	7	12 ⁷ / ₁₆	7 ¹³ / ₁₆	7 ⁷ / ₁₆	30

CAPACITIES — Cold Water (lbs/hr)

Model	PMO (PSIG)	Size	Differential Pressure (PSI)										
			2	5	10	25	50	80	100	125	150	180	200
WLD1501 WLD1521	150	3/4"	145	220	325	510	720	900	1010	1130	1215		
WLD1502 WLD1522	200	3/4"	170	260	380	595	835	1045	1175	1315	1410	1550	1645
WLD1504 WLD1524	200	1"	500	760	1105	1740	2460	3065	3450	3865	4140	4555	4835

HOW TO SIZE/ORDER

Determine differential pressure and capacity (lbs/hr) required. Locate differential pressure on capacity chart; move down column to capacity required. Make sure to select the correct model based on the required inlet pressure. Example:

Application: 200 lbs/hr at 30 PSIG working pressure and 5 PSI differential pressure

Size/Model: 3/4" WLD1521-150 @ 220 lbs/hr (with strainer)

LIQUID DRAINERS

WLD1703S

Thermodynamic Drain Trap

Watson McDaniel reserves the right to change the designs and/or materials of its products without notice.
©2010 Watson McDaniel Company

Model	WLD1703S
Sizes	1/2"
Connections	NPT
Body Material	Stainless Steel
Options	Blowdown Valve
PMO Max. Operating Pressure	250 PSIG
TMO Max. Operating Temperature	750°F
PMA Max. Allowable Pressure	915 PSIG up to 250°F
TMA Max. Allowable Temperature	610°F @ 750 PSIG

TYPICAL APPLICATION

The **WLD1703S** is used on air and gas applications as drip traps on system mains and other piping runs. These drain traps are ideal for outdoor applications where units are subject to freezing.

HOW IT WORKS

The thermodynamic liquid drain trap has a cyclic on/off operation with a disc that is pushed open when condensate is present and pulled closed when the gas tries to escape.

FEATURES

- Rugged, stainless steel body and hardened seat
- Handles a wide range of pressures up to 250 PSIG
- Works in any position (horizontal preferable)
- Integral strainer with blowdown option
- Three-holed balanced discharge
- Freezeproof in vertical flow-down position

SAMPLE SPECIFICATION

Drain Trap shall be thermodynamic disc type with an all stainless steel construction. Body shall have a built-in strainer with optional blowdown valve. Integral seat design and disc to be hardened for long service life. Unit shall be capable of installation in any orientation and self-draining when mounted vertically with flow direction downwards.

INSTALLATION

Drain Trap can be installed in any position; however, horizontal is preferred. Installation should include isolation valves for maintenance purposes.

MAINTENANCE

Dirt is the most common cause of premature failure. The strainer should be periodically cleaned. For full maintenance details see Installation and Maintenance Manual.



WLD1703SB with Strainer & Blowdown Valve

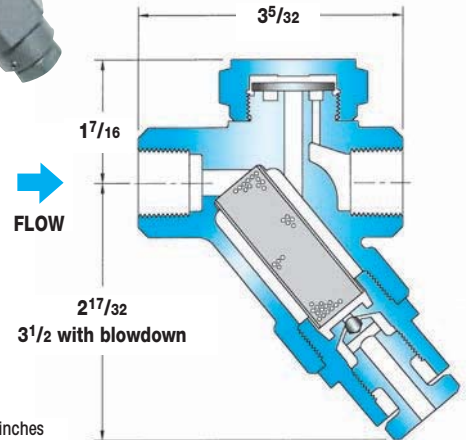

Units: inches

WLD1703S with Strainer
WLD1703SB with Strainer & Blowdown Valve

OPTIONS

Blowdown valve for easy maintenance.

MATERIALS

Body	Stainless Steel, AISI 420F
Disc	Stainless Steel, AISI 420
Cap	Stainless Steel, AISI 416
Strainer Screen	Stainless Steel, AISI 304
Blowdown Valve*	Stainless Steel, AISI 303

* WLD1703SB model only.

HOW TO SIZE/ORDER

Select working pressure in capacity chart; read number underneath to determine capacity (lbs/hr). Example:

Application: 500 lbs/hr at 80 PSIG inlet pressure

Size/Model: 1/2" **WLD1703S** @ 530 lbs/hr

CAPACITIES — Cold Water (lbs/hr)

Model	Size	Inlet Pressure (PSIG)											
		2	5	10	25	50	80	100	125	150	180	200	250
WLD1703S	1/2"	90	130	190	300	425	530	600	670	715	790	835	955
WLD1703SB	1/2"	90	130	190	300	425	530	600	670	715	790	835	955

Note: 1) Maximum back pressure not to exceed 80% of inlet pressure.

2) To determine gallons per minute of flow, divide values in chart by 500. Example: 600 lbs/hr = 600 ÷ 500 = 1.2 GPM

LIQUID DRAINERS

WLD1800/1800R Series

Guided Float Type Liquid Drain Trap

Model	WLD1800, WLD1800R
Sizes	1/2", 3/4"
Connections	NPT
Body Material	Stainless Steel
PMO Max. Operating Pressure	400 PSIG
TMO Max. Operating Temperature	500°F
PMA Max. Allowable Pressure	400 PSIG @ 500°F
TMA Max. Allowable Temperature	500°F @ 400 PSIG



WLD1800
(Non-Repairable)



WLD1800R
(Repairable)

TYPICAL APPLICATIONS

The **WLD1800/1800R Series** are used on industrial air and gas applications for drainage of liquid from systems.

HOW IT WORKS

This liquid drainer has a float-operated valve that gives the trap a modulating flow characteristic. The amount of liquid flowing into the drainer is sensed by the float which positions the main valve to discharge the liquid at the same rate as it is received.

FEATURES

- **Stainless steel body**
- **All stainless steel internals for longer service life**
- **Guided float ensures proper valve seating on every cycle**
- **Repairable unit available (WLD1800R)**

SAMPLE SPECIFICATION

The liquid drain trap shall have a guided-float operation with a tamper proof seal welded stainless steel body and all stainless steel internals. The unit shall be available with an in-line repairable version. All units to be equipped with FNPT threaded end connections.

INSTALLATION

The installation should include isolation valves to facilitate maintenance and an in-line strainer. The trap must be level and upright for the float mechanism to operate. Trap must be sized and properly located in the system.

MAINTENANCE

Close isolation valves prior to any maintenance. The WLD1800 is non-repairable unit. With the WLD1800R all working components can be replaced. Repair kits include float, lever & seat assembly, and gaskets. For full maintenance details see Installation and Maintenance Manual.

MATERIALS

Body	Stainless Steel, AISI 304
Inlet & Outlet Fittings	Stainless Steel, AISI 304
Float Assembly	Stainless Steel, AISI 304
Valve & Lever Assembly	Stainless Steel, AISI 303
Seat	Hardened Stainless Steel
*Gasket (Repairable only)	Grafoil
Washer, Seat	302 Stainless Steel
*Bolt, Hex, HD	Stainless Steel, AISI 316
*Nut, Jam	Stainless Steel, 18-8

* WLD1800R repairable models only.

LIQUID DRAINERS

WLD1800/1800R Series

Guided Float Type Liquid Drain Trap

DIMENSIONS — inches / pounds				
Model	Orifice Size	Size (Inlet x Outlet)	Height A	Weight (lbs)
WLD1811	.078"	3/4" x 1/2"	7.5	4
WLD1811R			7.9	5
WLD1812		3/4" x 3/4"	7.5	4
WLD1812R			7.9	5
WLD1813		1/2" x 1/2"	7.5	4
WLD1813R			7.9	5
WLD1821	.101"	3/4" x 1/2"	7.5	4
WLD1821R			7.9	5
WLD1822		3/4" x 3/4"	7.5	4
WLD1822R			7.9	5
WLD1823		1/2" x 1/2"	7.5	4
WLD1823R			7.9	5
WLD1831	.125"	3/4" x 1/2"	7.5	4
WLD1831R			7.9	5
WLD1832		3/4" x 3/4"	7.5	4
WLD1832R			7.9	5
WLD1833		1/2" x 1/2"	7.5	4
WLD1833R			7.9	5

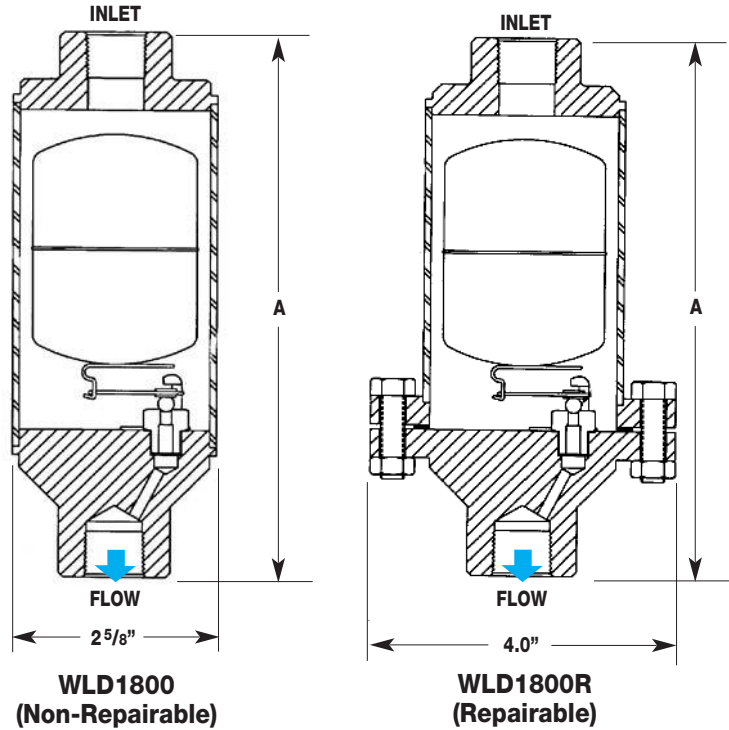

LIQUID DRAINERS

CAPACITIES — Cold Water (lbs/hr)																			
Series	PMO* (PSIG)	Orifice Size	Differential Pressure (PSI)																
			1	2	5	10	15	20	30	50	100	150	175	200	250	275	300	350	400
WLD1810	400	.078"	60	80	120	130	180	260	315	400	570	700	750	800	900	940	1050	1050	1120
WLD1820	255	.101"	90	120	175	195	275	385	470	610	860	1050	1125	1200	1350	1425			
WLD1830	175	.125"	160	230	325	365	510	730	790	1150	1630	2000	2150						

* PMO based on a liquid with a specific gravity of 1.0. Consult factory for the PMO of a liquid with specific gravity less than 1.0.

CAPACITY CORRECTION FACTORS																		
Specific Gravity	1	.98	.96	.94	.92	.90	.88	.86	.84	.82	.80	.75	.70	.65	.60	.55	.50	
Correction Factor	1	.99	.98	.97	.959	.949	.938	.927	.917	.906	.894	.886	.873	.860	.847	.834	.821	.807

Note: To obtain capacity with a liquid other than water, multiply water capacity by correction factor.

HOW TO SIZE/ORDER

Determine differential pressure and capacity (lbs/hr) required. Locate differential pressure on capacity chart; move down column to capacity required. Make sure to select the correct model based on the required inlet pressure. Example:

Application: 1,000 lbs/hr at 250 PSIG working pressure and 200 PSI differential pressure
 Size/Model: 3/4" x 3/4" **WLD1822** @ 1,200 lbs/hr (non-repairable) or 3/4" x 3/4" **WLD1822R** @ 1,200 lbs/hr (repairable)

WLD1900 Series

Float Type Liquid Drain Trap

Watson McDaniel reserves the right to change the designs and/or materials of its products without notice.
©2010 Watson McDaniel Company

Model	WLD1900
Sizes	3/4", 1", 1 1/4", 1 1/2", 2"
Connections	NPT
Body Material	Cast Iron
PMO Max. Operating Pressure	250 PSIG
TMO Max. Operating Temperature	450°F
PMA Max. Allowable Pressure	250 PSIG up to 450°F
TMA Max. Allowable Temperature	450°F @ 250 PSIG



WLD1900
3/4" & 1"



WLD1900
2"



WLD1900
1 1/4" & 1 1/2"

TYPICAL APPLICATIONS

The **WLD1900 Series** is used in applications where immediate and continuous discharge of liquid is required. Typically used in process applications for draining condensate from air or other gases.

HOW IT WORKS

This liquid drainer has a float-operated valve that gives the trap a modulating flow characteristic. The amount of liquid flowing into the drainer is sensed by the float which positions the main valve to discharge the liquid at the same rate as it is received.

FEATURES

- All stainless steel internals
- Hardened valve seat for longer service life
- Cast Iron body
- In-line repairable

SAMPLE SPECIFICATION

The liquid drain trap shall be float operated with a cast iron body, all stainless steel internals and a hardened valve seat. The unit shall be in-line repairable and equipped with a FNPT threaded connection for the use of a balance line.

INSTALLATION

The installation should include isolation valves to facilitate maintenance and an in-line strainer. The trap must be level and upright for the float mechanism to operate. Trap must be sized and properly located in the system.

MAINTENANCE

Close isolation valves prior to any maintenance. All working components can be replaced with the drain trap remaining in the pipeline. Repair kits include float, valve seat & disc, and gaskets. For full maintenance details see Installation and Maintenance Manual.

MATERIALS

Body	Cast Iron
Cover	Cast Iron
Gasket	Garlock 3400
Cover Screws	Stainless Steel, Gr 5
Float	Stainless Steel, AISI 304
Internals	Stainless Steel, 300 Series
Valve Seat	Stainless Steel, 17-4 PH
Valve Disc	Stainless Steel, AISI 420F

LIQUID DRAINERS

WLD1900 Series

Watson McDaniel reserves the right to change the designs and/or materials of its products without notice.
©2010 Watson McDaniel Company

Float Type Liquid Drain Trap

DIMENSIONS – inches/pounds

Drawing	Model	Size	PMO (PSIG)	Weight (lbs)
A	WLD1913-015	3/4"	15	9
A	WLD1914-015	1"	15	9
A	WLD1915-015	1 1/4"	15	9
C	WLD1916-015	1 1/2"	15	21
D	WLD1917-015	2"	15	53
A	WLD1913-030	3/4"	30	9
A	WLD1914-030	1"	30	9
A	WLD1915-030	1 1/4"	30	9
C	WLD1916-030	1 1/2"	30	21
D	WLD1917-030	2"	30	53
A	WLD1913-090	3/4"	90	9
A	WLD1914-090	1"	90	9
C	WLD1915-090	1 1/4"	90	21
C	WLD1916-090	1 1/2"	90	21
D	WLD1917-090	2"	90	53
A	WLD1913-150	3/4"	150	9
A	WLD1914-150	1"	150	9
C	WLD1915-150	1 1/4"	150	21
C	WLD1916-150	1 1/2"	150	21
D	WLD1917-150	2"	150	53
B	WLD1913-200	3/4"	200	20
B	WLD1914-200	1"	200	20
C	WLD1915-200	1 1/4"	200	21
C	WLD1916-200	1 1/2"	200	21
D	WLD1917-200	2"	200	53
B	WLD1913-250	3/4"	250	20
B	WLD1914-250	1"	250	20
C	WLD1915-250	1 1/4"	250	21
C	WLD1916-250	1 1/2"	250	21
D	WLD1917-250	2"	250	53

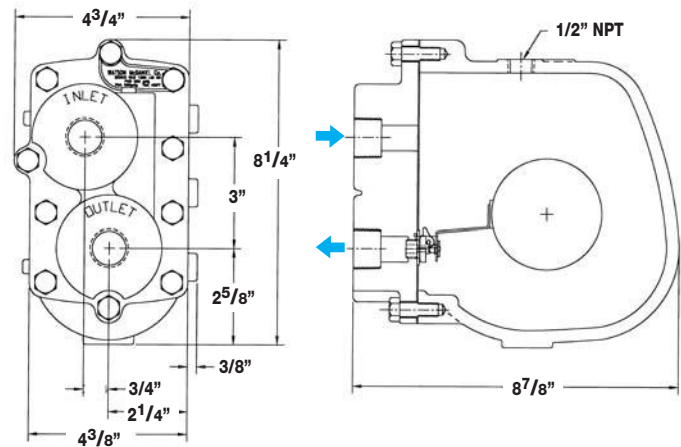

DRAWING - B

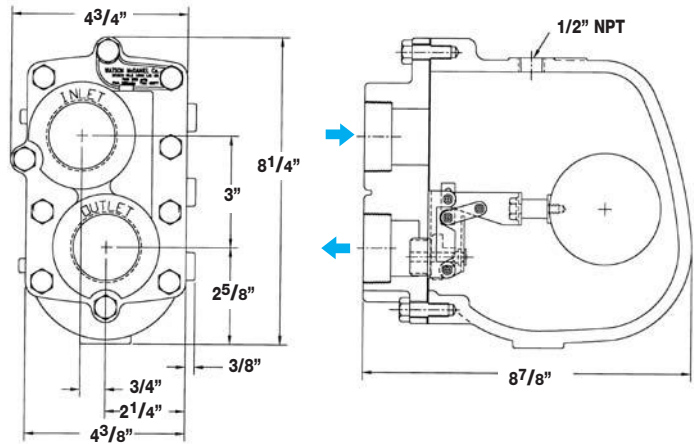

DRAWING - C

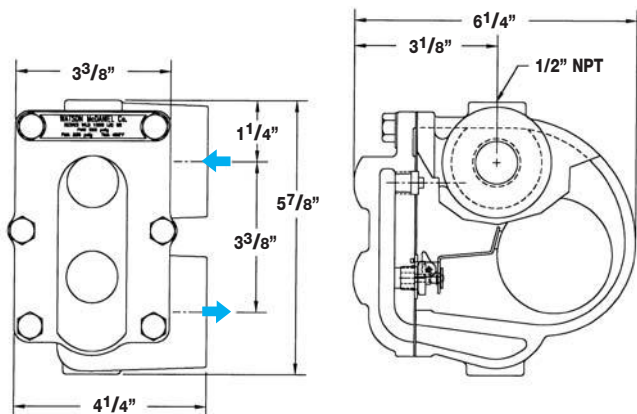

DRAWING - A

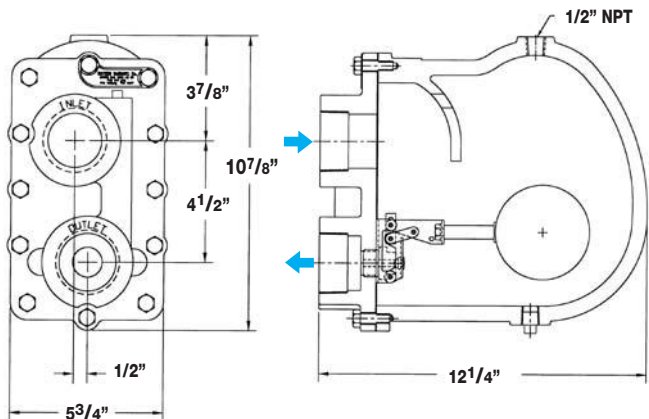

DRAWING - D

LIQUID DRAINERS

LIQUID DRAINERS

WLD1900 Series

Float Type Liquid Drain Trap

HOW TO SIZE/ORDER

Determine differential pressure and capacity (lbs/hr) required. Locate differential pressure on capacity chart; move down column to capacity required. Make sure to select the correct model based on the required inlet pressure. Example:

Application: 3,000 lbs/hr at 30 PSIG working pressure and 5 PSI differential pressure

Size/Model: 1 1/2" **WLD1916-030**

CAPACITIES – Cold Water (lbs/hr)

Model	Size	PMO (PSIG)	Orifice Size	Differential Pressure (PSI)																
				1	2	5	10	15	20	30	40	50	75	100	125	150	175	200	225	250
WLD1913-015	3/4"	15	.250"	910	1260	1940	2690	3260												
WLD1914-015	1"	15	.250"	910	1260	1940	2690	3260												
WLD1915-015	1 1/4"	15	.312"	1130	1570	2420	3360	4070												
WLD1916-015	1 1/2"	15	.500"	2400	3330	5140	7140	8650												
WLD1917-015	2"	15	.625"	3000	4170	6430	8920	10810												
WLD1913-030	3/4"	30	.228"	830	1150	1770	2450	2970	3410	4130										
WLD1914-030	1"	30	.228"	830	1150	1770	2450	2970	3410	4130										
WLD1915-030	1 1/4"	30	.228"	830	1150	1770	2450	2970	3410	4130										
WLD1916-030	1 1/2"	30	.390"	2200	3060	4710	6540	7930	9080	11000										
WLD1917-030	2"	30	.500"	2400	3330	5140	7140	8650	9910	12000										
WLD1913-090	3/4"	90	.166"	260	360	550	770	930	1060	1290	1480	1640	1990							
WLD1914-090	1"	90	.166"	260	360	550	770	930	1060	1290	1480	1640	1990							
WLD1915-090	1 1/4"	90	.312"	1130	1570	2420	3360	4070	4660	5650	6470	7190	8710							
WLD1916-090	1 1/2"	90	.312"	1130	1570	2420	3360	4070	4660	5650	6470	7190	8710							
WLD1917-090	2"	90	.422"	1350	1870	2890	4010	4860	5570	6740	7730	8590	10400							
WLD1913-150	3/4"	150	.128"	150	210	330	450	550	630	760	870	970	1170	1340	1490	1590				
WLD1914-150	1"	150	.128"	150	210	330	450	550	630	760	870	970	1170	1340	1490	1590				
WLD1915-150	1 1/4"	150	.250"	910	1260	1940	2690	3260	3740	4530	5190	5760	6980	8000	8890	9800				
WLD1916-150	1 1/2"	150	.250"	910	1260	1940	2690	3260	3740	4530	5190	5760	6980	8000	8890	9800				
WLD1917-150	2"	150	.332"	1200	1670	2580	3580	4330	4960	6010	6890	7650	9270	10620	11810	12500				
WLD1913-200	3/4"	200	.166"	260	360	550	770	930	1060	1290	1480	1640	1990	2280	2530	2760	2970	3150		
WLD1914-200	1"	200	.166"	260	360	550	770	930	1060	1290	1480	1640	1990	2280	2530	2760	2970	3150		
WLD1915-200	1 1/4"	200	.250"	910	1260	1940	2690	3260	3740	4530	5190	5760	6980	8000	8890	9690	10420	11100		
WLD1916-200	1 1/2"	200	.250"	910	1260	1940	2690	3260	3740	4530	5190	5760	6980	8000	8890	9690	10420	11100		
WLD1917-200	2"	200	.281"	1960	2720	4200	5830	7060	8090	9800	11230	12480	15120	17320	19250	20980	22570	23800		
WLD1913-250	3/4"	250	.128"	150	210	330	450	550	630	760	870	970	1170	1340	1490	1630	1750	1860	1970	2070
WLD1914-250	1"	250	.128"	150	210	330	450	550	630	760	870	970	1170	1340	1490	1630	1750	1860	1970	2070
WLD1915-250	1 1/4"	250	.203"	600	830	1280	1770	2150	2460	2980	3420	3800	4600	5270	5860	6390	6870	7320	7740	8140
WLD1916-250	1 1/2"	250	.203"	600	830	1280	1770	2150	2460	2980	3420	3800	4600	5270	5860	6390	6870	7320	7740	8140
WLD1917-250	2"	250	.250"	910	1260	1940	2690	3260	3740	4530	5190	5760	6980	8000	8890	9690	10420	11100	11740	12340

LIQUID DRAINERS

Installation Guidelines

Watson McDaniel reserves the right to change the designs and/or materials of its products without notice.
©2010 Watson McDaniel Company

for Liquid Drain Traps

PROPER INSTALLATION OF LIQUID DRAINERS

Liquid Drain Traps are primarily used to remove condensation from air and other non-condensable gas lines. The proper liquid drain trap should be selected based on several parameters, including installation limitations, pressure conditions and the amount of liquid to be drained.

If a **Ball & Float Type Drain Trap** is selected, typically it is necessary to add a Balancing (or Equalizing) Line to allow any air or gases trapped in the drainer to escape. If the Balancing Line is not installed, these gases can prevent proper operation by air-binding the trap. Inverted Bucket Type & Disc Type Traps will self-vent eliminating the risk of air-binding and therefore do not require Balancing Lines.

Figure 1 Draining Condensate from an Air Line Drip Pocket with a Float Type Drainer

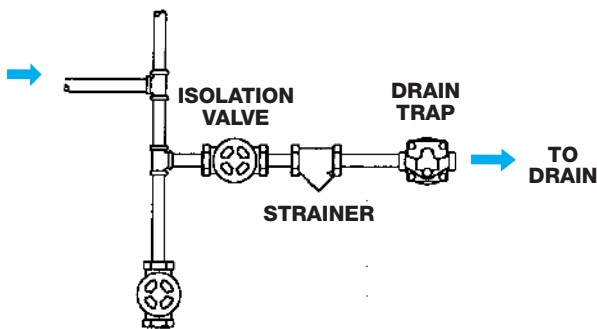

Due to the small amount of condensate normally found in drip leg applications, a small Ball & Float Type Liquid Drainer can be used and a Balancing Line is not required. However, a minimum pipe connection size of 3/4" is recommended for this type of application.

Figure 2 Draining Condensate from a Separator on a Large Air Main with a Float Type Drainer

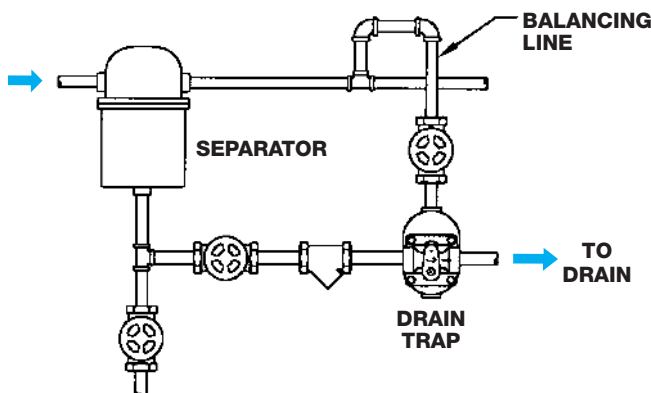

Due to the large amount of condensate normally found in air mains or from the discharge of air compressors, a larger Ball & Float Type Liquid Drainer must be used and a Balancing Line is required.

Installation Guidelines

for Liquid Drain Traps (continued)

Figure 3 Draining Condensate from a Receiver with a Float Type Drainer

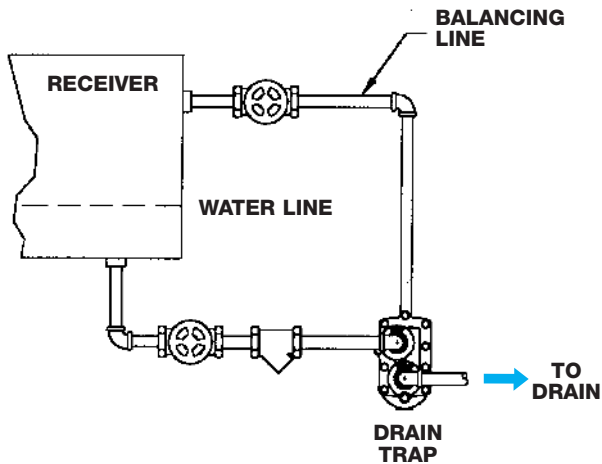

When draining a receiver, a large trap is typically required in order to handle the liquid load. If a Ball & Float Type Liquid Drainer is used, a Balancing Line is required. Make certain that the Balancing Line connection to the receiver is above the water line.

Figure 4 Draining Condensate from a Receiver with an Inverted Bucket Trap

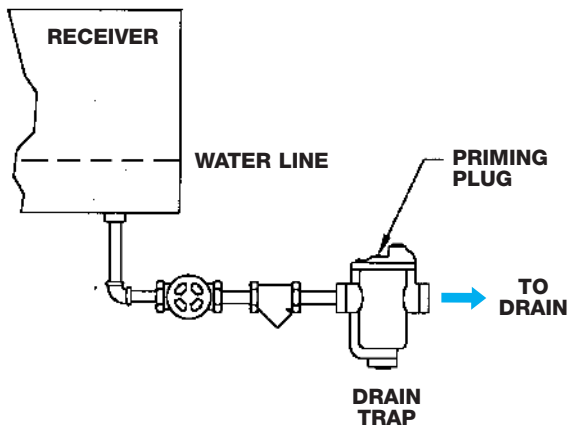

In this example, an Inverted Bucket Type Liquid Drain Trap is used. The Inverted Bucket Trap has a small internal orifice which permits the venting of air, and therefore does not require a Balancing Line. However, it is important to make certain that the Inverted Bucket Trap is primed with liquid before operation.

Note: See installation manual for proper priming procedures.

Specialty Products



STAINLESS STEEL CHECK VALVES

Watson McDaniel Check Valves are available in all 316 SS construction in 1/2" thru 3" sizes and were specifically designed to handle the difficult environments associated with steam and hot condensate service. As a standard procedure, check valves should be installed on the discharge side of all steam traps to eliminate backflow into the trap. With the specially designed 1/4 PSI low cracking pressure spring, these check valves come standard on all Watson McDaniel Pressure Motive Pumps.



Y-STRAINERS

Strainers remove scale and dirt from steam systems and are designed to protect critical components such as Regulators and Steam Traps from damage. These strainers are available in Cast Iron, Carbon Steel and Stainless Steel up to 4" in size.



SUCTION/MIXING TEES

This is a unique and specialized product used for blending, mixing, aeration or even heating by mixing steam and water together. Available in Cast Iron, Bronze and Stainless Steel.



DRIP PAN ELBOWS

Drip Pan Elbows are used to collect and remove condensate. Typically used with steam boilers, pressure relief valves, safety valves and steam pressure vessels and lines.



EJECTORS

Ejectors are used for non electric pumping of fluids or evacuating a tank or vessel of air or other gases. Commonly used on sterilizing equipment for pre and post evacuation of the chamber.



AIR ELIMINATORS

Air Eliminators are used on tanks or piping systems to vent entrained air without allowing the liquid inside the tank or piping to escape. Available in Cast Iron and Stainless Steel.

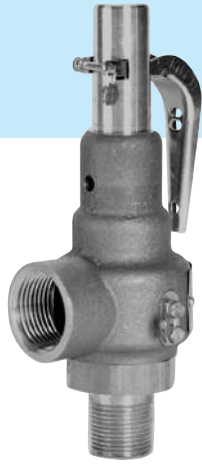

SAFETY RELIEF VALVES

Pressure relief valve standards regarding design, installation, performance and certification are covered in codes developed by the American Society of Mechanical Engineers (ASME) in Section I (for power boilers) and Section VIII (for pressure vessels). Watson McDaniel Safety Relief Valves are ASME qualified for steam service and are available in Bronze and Cast Iron in 1/2" thru 6" sizes.

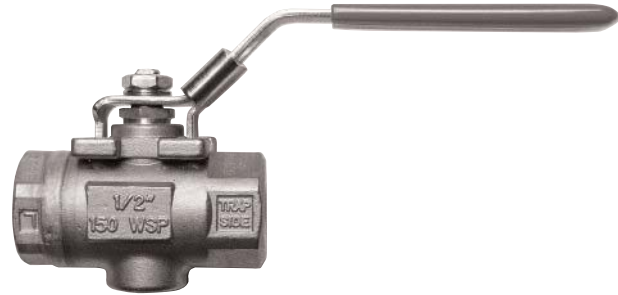

STEAM TRAP TEST VALVES

Test Valves can be installed downstream of any steam trap to visually inspect the discharge of condensate from the traps. Available in Bronze and Stainless Steel up to 1" in size.



EXHAUST HEADS

Exhaust heads are used to separate entrained water from steam prior to being discharged directly to the atmosphere, preventing damage to rooftops and other equipment.



VACUUM BREAKERS

Vacuum Breakers "break the vacuum" caused by the condensing of steam or draining of liquid. These are primarily positioned on the top of heat exchangers, allowing condensate to properly drain from the system.



FREEZE/SCALD PROTECTION VALVES

Freeze Protection valves automatically open and dump liquid to protect equipment from freeze damage. Scald Protection valves automatically open and dump overheated liquid from a system to protect personnel from possible injury due to scalding.



STEAM HUMIDIFIERS

Watson McDaniel offers a complete line of steam humidification products for controlling humidity in commercial offices, hospitals, warehouses and various types of industrial facilities.



THERMOSTATIC AIR VENTS

Air Vents purge unwanted air from steam systems which can inhibit the steam from entering process equipment, vessels and piping. Air vents should be placed at all high points in the system but primarily on all pieces of heat transfer equipment.



AIR/STEAM MOISTURE SEPARATORS

Separators are used for the removal of entrained moisture in steam and compressed air lines. Separators should be placed before all regulating valves to eliminate problems caused by water logging and wire drawing of the valve seats.

SPECIALTY PRODUCTS

Specialty Products

Model/Series	Product	Body Material	PMO (PSIG)	Sizes	Connection	Page No.
WSI, WIP, WSX	Steam Humidifiers	Stainless Steel	60	–	–	227-231
WSVB	Safety Relief Valve	Bronze	250	1/2" - 2 1/2"	NPT	232-233
WSVI	Safety Relief Valve	Cast Iron	250	1 1/2" - 6"	NPT, FLG	234-235
WCYI	Strainer	Cast Iron	125-500	1/2" - 4"	NPT, FLG	236
WCSY	Strainer	Carbon Steel	600	1/2" - 2"	NPT, SW	237
WSSY	Strainer	Stainless Steel	600	1/2" - 2"	NPT, SW	237
SUCTION TEE	Mixing Tee	Cast Iron, Bronze, SS	250-450	1/2" - 3"	NPT	238-239
W-EJECT/ELL/LM	Ejector	Cast Iron, Bronze	100	1/2" - 2"	NPT	240-243
AV813W	Air Eliminator	Cast Iron	150	3/4"	NPT	244
AE1800/1800R	Air Eliminator	Stainless Steel	400	1/2", 3/4"	NPT	245
AV2000C	Air Vent	Stainless Steel	650	1/2", 3/4"	NPT	246
AVT125	Air Vent	Brass	125	1/2", 3/4"	NPT	247
WDS	Separator	C.I., Carbon Steel	250/300	3/4" - 12"	NPT, SW, FLG	248-249
WCIS	Separator	Cast Iron	145/200	3/4" - 4"	NPT, FLG	250-251
WEH	Exhaust Head	C.I., Carbon Steel, SS	NA	1" - 10"	NPT, FLG	252-253
WVBSS	Vacuum Breaker	Stainless Steel	300	1/2"	NPT	254
WSSCV	Check Valve	Stainless Steel	500	1/2" - 3"	NPT, SW	255
WFPV	Freeze Protection Valve	Stainless Steel	200	1/2"	NPT	256
WSPV	Scald Protection Valve	Stainless Steel	200	1/2", 3/4"	NPT	257
WDPL	Drip Pan Elbow	Cast Iron	250	3/4" - 8"	NPT, FLG	258
WFLV	Flash Tank	Carbon Steel	150	6", 8", 12", 16"	FLG	259
WSTTV	Steam Trap Test Valve	Bronze, Stainless Steel	150	1/2" - 1"	NPT	260

Steam Humidifiers

Steam Injection

Humidification Overview

Single Tube Humidifier

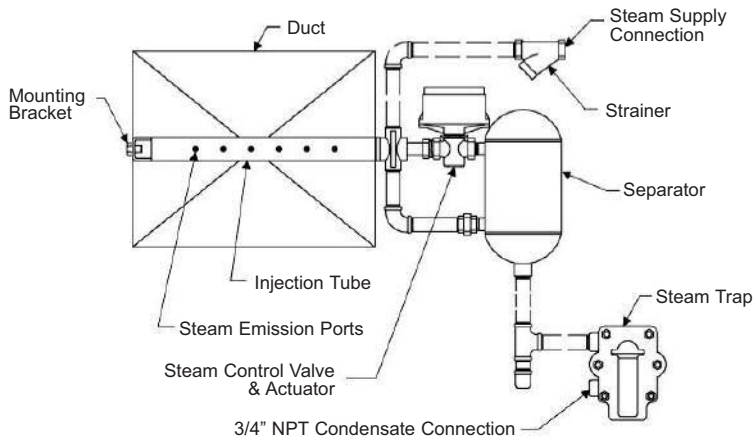

Single Tube (WSI)

- For direct injection of steam humidification into air stream
- Many tube length options to accommodate various duct widths
- Recommended for relatively small duct heights where dissipation distance is not critical

Multiple Tube Humidifier

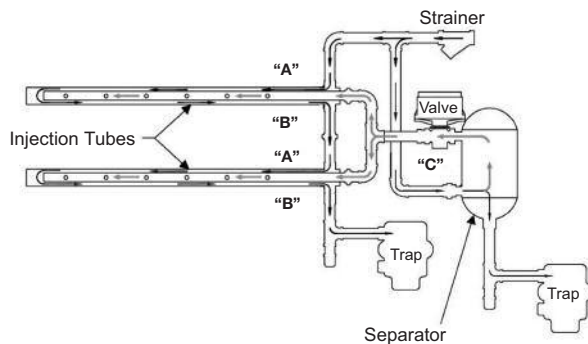

Multiple Tube (WSI)

- Used for improved dissipation distances in duct heights above 20"
- Number of tubes can be selected to optimize performance
- Many tube length options to accommodate various duct widths

Insty-Pac Manifold-Style Humidifier

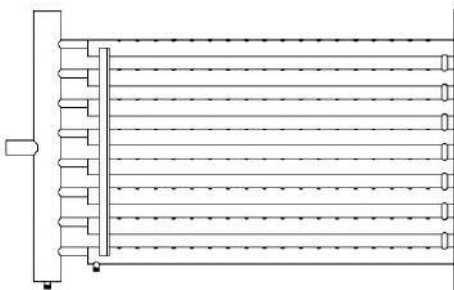

Insty-Pac (WIP)

- Custom-engineered manifold design for job-specific requirements
- Used when dissipation distances are critical for optimum air stream humidification
- Number of tubes properly selected to achieve design requirements

SPECIALTY PRODUCTS

Steam Humidifiers

Steam Injection

Watson McDaniel reserves the right to change the designs and/or materials of its products without notice.
©2010 Watson McDaniel Company

Humidification Overview



Steam Heat Exchanger (WSX)

- Provides humidification for today's stringent indoor air quality requirements
- Utilizes boiler steam to heat tap water providing injection steam free from chemical or mineral carry-over
- Ideal for use where electric humidifiers would be cost-prohibitive

Mini-Mult Front View

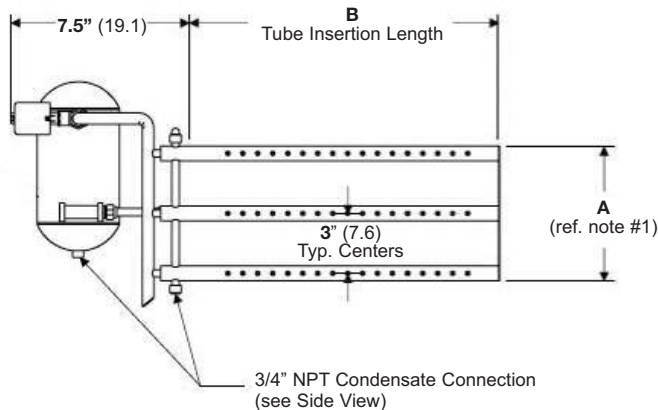

Mini-Mult

- Designed for applications that require small humidification loads in a small duct size
- Ideal for any high humidity job where fast steam dissipation in cool air in a short-run duct is essential
- Number of tubes can be specified per duct size and job requirements

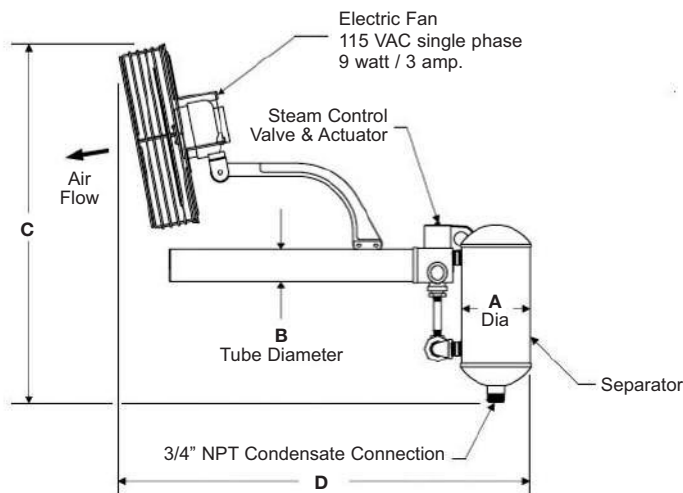

Area Type

- Designed for applications that require humidification without the use of duct work
- Ideal for area humidity control in paper, textile or wood manufacturing applications as well as printing plants and storage areas

SPECIALTY PRODUCTS

WSI & WIP

Steam Humidifiers



**Series "WSI"
Steam Injection
Humidifiers**



**Series "WIP"
INSTY-PAC
Steam Injection
Humidifiers**

TYPICAL APPLICATIONS

A Steam Injection Humidifier supplies precise humidity control from the facility steam boiler into the air stream. Typically used in manufacturing plants, printing plants, commercial offices, hospitals and any other facilities which require a critical balance between temperature and humidity control.

HOW IT WORKS

The Steam Injection Humidifier receives steam directly from the boiler (live steam), removes the condensate and injects the dry steam into the duct work or an air stream. Live steam enters a steam jacket to preheat the injection tube. Steam then flows into the separator where condensate is removed. Dry steam is then discharged through the injection tube for circulation into the air stream.

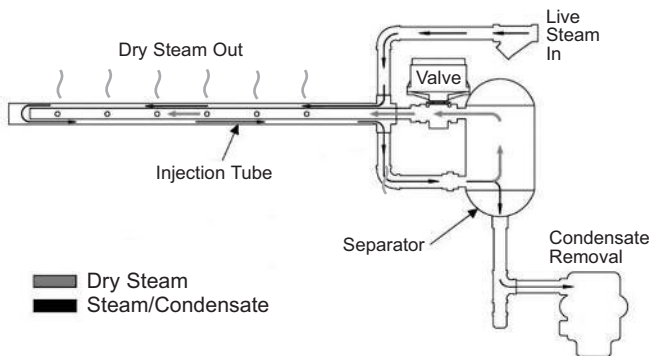

MATERIALS

Separator	304 SS
Dispersion Tube	304 SST

FEATURES

- Provides accurate humidity control
- Simple and cost efficient system to meet high humidity requirements
- Available for regular or purified boiler steam
- Available for single or multiple tube applications
- Capacities up to 2900 lbs/hr
- Pressure ranges from 2-60 PSIG
- Available for pneumatic or electric controls
- All stainless steel distributors and nozzles ensure permanent bond
- Separator & Steam Jacket included to provide highest quality steam

INSTALLATION

Distributor must be mounted level in a straight section of duct, with steam outlets facing into the air stream. A steam trap should be installed on the separator outlet, allowing for proper condensate removal. Also include a strainer upstream of humidifier inlet.

MAINTENANCE

The strainer should be cleaned periodically. The valve, actuator, steam trap and temperature switch should be inspected annually to confirm proper operation. For full maintenance details, see installation and maintenance manual.

HOW TO ORDER

Consult factory for sizing and selection. Provide required humidification load, steam pressure at humidifier inlet, duct dimensions, actuator type and any accessories.

SPECIALTY PRODUCTS

WSI & WIP

Watson McDaniel reserves the right to change the designs and/or materials of its products without notice.
©2010 Watson McDaniel Company

Steam Humidifiers

Single Tube

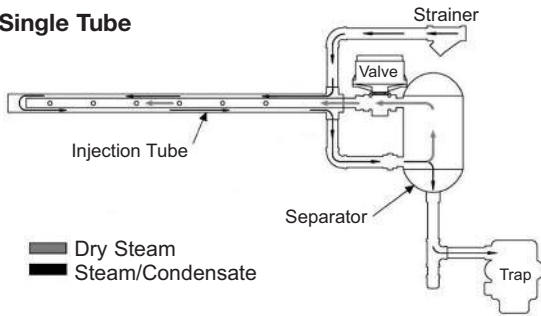

Multiple Tube

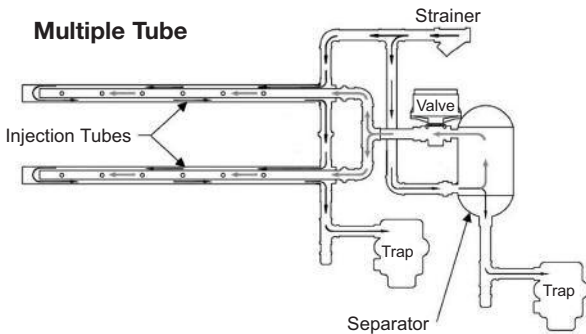

Insty-Pac Tube

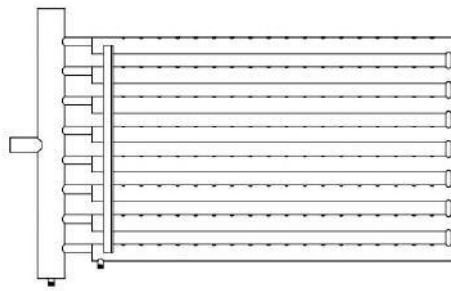
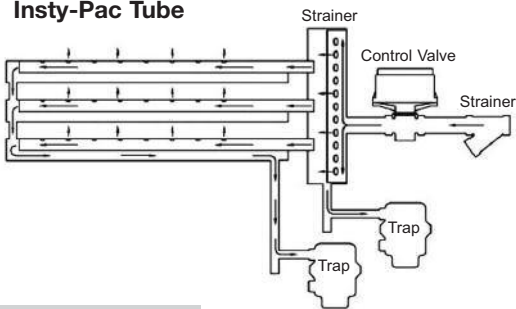

To prevent condensation on in-duct objects, such as dampeners, coils, filters or turning vanes, it is very important that the dissipation distance be shorter than the distance from the humidifier to the in-duct object. The following recommendations should be used when designing a multiple injection tube system:

Duct Height	Recommended Qty. of Tubes †
Up to 36"	2
37" - 48"	3
49" - 72"	4
73" - 96"	5
Above 96"	6

† Final duct relative humidity, air velocity and available dissipation distance will affect the quantity of tubes required.

MODEL NUMBERS

Insty Pac	Single Tube	Multi Tube	Valve / Size Cv / NPT	Steam Pressure to Humidifier Supply Connection (PSIG)																						
				2	3	4	5	6	7	8	9	10	11	12	13	14	15	20	25	30	35	40	45	50	55	60
BP-1	50-10	50	.10 (1/2")	1.6	1.9	2.3	2.6	2.8	3.0	3.2	3.4	3.6	3.8	4.0	4.2	4.3	4.4	5.1	5.7	6.3	6.8	7.3	7.7	8.1	8.5	8.9
			.22 (1/2")	3.5	4.2	5.0	5.6	6.5	6.6	7.1	7.6	8	8	9	9	10	10	11	13	14	15	16	17	18	19	20
			.40 (1/2")	6.4	7.6	9.1	10	11	12	13	14	15	15	16	16	17	18	20	23	25	27	29	31	33	34	36
			.75 (1/2")	12	14	17	19	21	23	24	26	27	28	30	31	32	33	38	43	47	50	54	57	60	63	66
			.95 (1/2")	15	18	21	24	27	29	31	33	34	36	38	39	40	42	48	54	59	64	68	72	76	80	84
			1.30 (1/2")	21	24	29	33	36	39	42	44	47	49	51	53	55	57	66	74	80	87	93	99	104	109	114
			1.75 (1/2")	28	33	40	44	49	52	55	60	63	66	69	72	74	76	88	99	107	116	124	132	139	146	153
			2.20 (1/2")	35	41	50	55	61	66	71	75	79	82	86	90	93	95	111	123	134	146	156	165	174	183	192
			2.80 (1/2")	45	53	64	70	78	84	90	96	100	104	109	114	118	121	141	157	171	186	199	210	221	233	244
			3.25 (1/2")	52	61	73	82	90	96	104	110	116	121	127	132	137	140	163	181	198	214	229	244	257	270	282
BP-2	60-20	60	4.40 (1/2")	70	83	98	110	121	130	141	149	157	163	172	178	185	190	221	244	256	290	310	328	345	363	381
			5.50 (3/4")	85	104	123	138	150	161	176	186	196	204	213	222	231	235	275	305	333	360	385	408	430	451	471
			6.20 (3/4")	96	117	138	155	169	182	198	210	220	230	240	250	259	265	310	343	372	403	434	459	485	508	529
BP-3	70-20	70	7.50 (3/4")	116	142	166	186	204	220	238	253	265	277	289	302	312	320	373	412	450	487	525	555	585	614	640
			8.20 (1")	123	155	180	204	223	240	261	275	290	303	313	328	341	349	407	443	488	529	570	603	635	668	703
BP-4	80-30	80	10.0 (1")	150	189	220	248	272	293	317	335	354	370	380	400	414	423	497	540	595	645	695	735	770	810	850
			12.0 (1")	180	228	264	296	326	351	378	402	422	441	456	465	492	505	595	648	714	774	828	876	-	-	-
BP-5	N/A	90	20.0 (1-1/4")	300	375	440	494	540	582	630	666	702	736	750	772	814	834	990	1060	1180	1280	1376	1460	-	-	-
			28.0 (1-1/4")	420	511	612	686	756	812	873	927	980	1024	1044	1075	1128	1165	1383	1484	1638	1778	1912	2044	-	-	-

SPECIALTY PRODUCTS

TYPICAL APPLICATIONS

Steam Heat Exchanger Humidifiers can be used for humidification applications where steam injection is to be used, but chemically treated boiler steam is not allowable. They provide humidification to meet stringent indoor air quality requirements and are ideal for use where electric humidifiers would be cost-prohibitive.

HOW IT WORKS

The WSX Steam Heat Exchanger Humidifier works by utilizing existing boiler steam to heat tap water, providing injection steam free from chemical or mineral carry-over. Several steam injection dispersion methods are available to suit the application requirements.

FEATURES

- Single unit capacity up to 2,035 lbs/hr
- 304 Stainless Steel reservoir construction
- Stainless Steel heat exchanger
- Unique side-entry heat exchanger provides a large clean out access section without disturbing the cover or injection tube system's steam supply piping
- Pneumatic modulating steam control valve
- Tri-Probe level controller
- Adjustable surface water flusher
- Motorized drain valve with brass body
- User-adjustable automatic drain system
- Float & Thermostatic steam trap(s)
- Inlet "Y" strainer(s)



OPTIONS

- INTAC microprocessor controller
- Electric modulating actuator
- Factory-mounted control panel
- NEMA 4 weather-tight control panel
- Control panel door lock
- Seasonal End-of-Use drain system
- Door interlock safety switch
- Factory-insulated reservoir
- Support legs
- Wall brackets
- Freeze protection
- Stand-by water temperature sensing
- Blower Pack for area humidification
- Variable air volume control
- Outdoor air temperature sensing
- Drain tempering kit
- Remote INTAC microprocessor controller
- Outdoor enclosure

Humidifier Capacity – lbs/hr (kg/hr) †

Model	Steam Pressure in at the control valve – PSIG (kPa)			
	5 (34.5)	10 (69.0)	13 (89.6)	15 (103.4)
SX-1R	32 (14.5)	76 (34.5)	100 (45.3)	122 (55.3)
SX-2R	52 (23.6)	108 (48.9)	140 (63.5)	169 (76.7)
SX-3R	102 (46.3)	228 (103.4)	292 (132.5)	348 (157.8)
SX-4R	192 (87.1)	484 (219.5)	655 (297.1)	753 (341.7)
SX-8R	370 (167.8)	840 (381.0)	1200 (544.3)	1350 (612.4)
SX-12R	560 (254.0)	1265 (573.8)	1810 (821.0)	2035 (923.1)

† Actual humidifier capacity may vary due to the heat loss from the humidifier reservoir. The ambient air temperature, air velocity and injection tube system will affect the rate of the heat loss from the reservoir.

The capacities shown are based on a non-insulated humidifier reservoir tested in a 70°F environment.

SPECIALTY PRODUCTS

WSVB Series

Watson McDaniel reserves the right to change the designs and/or materials of its products without notice.
©2010 Watson McDaniel Company

Safety Valves "UV" Steam-ASME Section VIII Pressure Vessels

Model	WSVB
Sizes	1/2", 3/4", 1", 1 1/4", 1 1/2", 2", 2 1/2"
Connections	NPT
Body Material	Bronze
PMO Max. Operating Pressure	250 PSIG (steam)
TMO Max. Operating Temperature	406 °F

TYPICAL APPLICATIONS

The **WSVB** Safety Relief Valves are used for over-pressure protection on unfired pressure vessels in saturated steam systems.

HOW IT WORKS

As safety valves open on a non-compressible fluid application, the disc lifts directly proportional to the increase in system pressure over the valve set point. Safety relief valves not only provide over pressure protection resulting from thermal expansion of liquids, but will respond with a rapid full opening "pop" action on systems which contain or generate steam, air or gas.

FEATURES

- **Stainless Steel springs**
- **Teflon®-PFA seat resists corrosive boiler chemicals**
- **Two control rings for maximum performance & adjustability**
- **Tapped body drain allows piping of condensate away from equipment**

SAMPLE SPECIFICATION

Safety valves shall be cast bronze construction with stainless steel springs, Teflon-PFA seats and stainless steel stems. Units shall be qualified to the ASME Boiler Code, Section VIII and suitable for steam service.

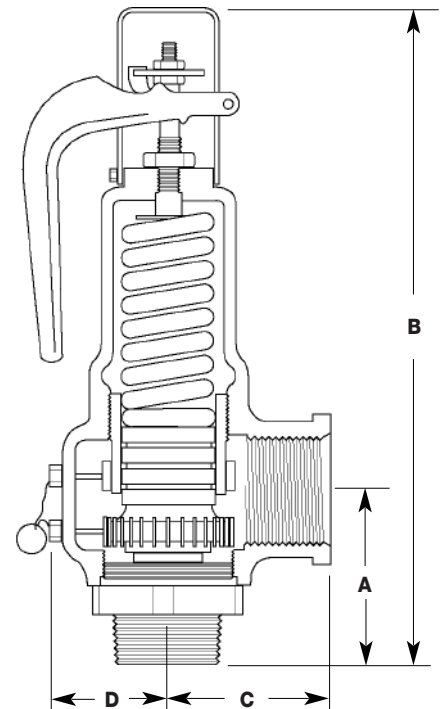

DIMENSIONS & WEIGHTS – inches / pounds

Model No.	Orifice Size	Inlet x Outlet MNPT x FNPT	A	B	C	D	Weight (lbs)
WSVB-12M-13S-D	D	1/2" x 3/4"	2.21	6.52	1.37	0.84	1.6
WSVB-13M-13S-D	D	3/4" x 3/4"	2.21	6.52	1.37	0.84	1.6
WSVB-13M-14S-E	E	3/4" x 1"	2.50	7.16	1.75	1.06	2.0
WSVB-14M-14S-E	E	1" x 1"	2.64	7.30	1.75	1.06	2.2
WSVB-14M-15S-F	F	1" x 1 1/4"	2.95	9.34	2.00	1.44	4.1
WSVB-15M-15S-F	F	1 1/4" x 1 1/4"	2.95	9.34	2.00	1.44	4.3
WSVB-15M-16S-G	G	1 1/4" x 1 1/2"	3.38	11.01	2.37	1.69	7.4
WSVB-16M-16S-G	G	1 1/2" x 1 1/2"	3.38	11.01	2.37	1.69	7.6
WSVB-16M-17S-H	H	1 1/2" x 2"	3.63	11.96	2.75	2.06	11.5
WSVB-17M-17S-H	H	2" x 2"	3.63	11.96	2.75	2.06	11.6
WSVB-16S-18S-J	J	1 1/2" FNPT x 2 1/2" FNPT	3.80	14.00	3.50	2.06	20.0
WSVB-17M-18S-J	J	2" x 2 1/2"	4.06	14.25	3.50	2.06	19.9
WSVB-18M-18S-J	J	2 1/2" x 2 1/2"	4.50	14.68	3.50	2.06	20.8

MATERIALS

Body	Bronze
Guide Ring	Brass
Disc	Brass
Seat Insert	Teflon®-PFA
Stem	SST

SPECIALTY PRODUCTS

WSVB Series

Safety Relief Valves "UV" Steam-ASME Section VIII Pressure Vessels

CAPACITIES – Pounds of saturated steam per hour (lbs/hr)						
Set Pressure (PSIG)	Orifice "D" .129" Diameter	Orifice "E" .230" Diameter	Orifice "F" .359" Diameter	Orifice "G" .586" Diameter	Orifice "H" .919" Diameter	Orifice "J" 1.509" Diameter
15	179	320	499	820	1279	2100
20	207	369	576	945	1474	2421
25	234	418	652	1070	1670	2742
30	262	467	729	1195	1865	3063
35	292	521	813	1333	2080	3416
40	322	574	897	1471	2295	3769
45	352	628	981	1609	2510	4122
50	383	682	1065	1747	2725	4475
55	413	736	1149	1885	2941	4828
60	443	790	1233	2022	3156	5181
65	473	844	1317	2160	3371	5535
70	503	897	1401	2298	3586	5888
75	534	951	1485	2436	3801	6241
80	564	1005	1569	2574	4016	6594
85	594	1059	1653	2712	4231	6947
90	624	1113	1737	2849	4446	7300
95	654	1167	1821	2987	4661	7653
100	684	1220	1905	3125	4876	8007
105	715	1274	1989	3263	5091	8360
110	745	1328	2073	3401	5306	8713
115	775	1382	2157	3539	5521	9066
120	805	1436	2241	3677	5736	9419
125	835	1489	2325	3814	5951	9772
130	866	1543	2409	3952	6167	10125
135	896	1597	2493	4090	6382	10479
140	926	1651	2577	4228	6597	10832
145	956	1705	2661	4366	6812	11185
150	986	1759	2745	4504	7027	11538
155	1017	1812	2829	4641	7242	11891
160	1047	1866	2913	4779	7457	12244
165	1077	1920	2997	4917	7672	12597
170	1107	1973	3081	5055	7887	12951
180	1167	2081	3249	5331	8317	13657
190	1228	2189	3417	5606	8747	14363
200	1288	2296	3585	5882	9177	15069
210	1349	2404	3753	6158	9608	15776
220	1409	2512	3921	6433	10038	16482
230	1469	2619	4089	6709	10468	17188
240	1530	2727	4257	6985	10898	17894
250	1590	2834	4425	7260	11328	18601
Approx. 1 PSI Incr.	6.0	10.8	16.8	27.6	43.0	70.6

Notes: 1) Ratings are 90% of actual capacity.
 2) For Set Pressures over 250 PSIG, consult factory.
 3) For other sizes, consult factory.

SPECIALTY PRODUCTS

SPECIALTY PRODUCTS

WSVI Series

Watson McDaniel reserves the right to change the designs and/or materials of its products without notice.
©2010 Watson McDaniel Company

Safety Valves "UV" Steam-ASME Section VIII Pressure Vessels

Model	WSVI
Sizes	1 1/2", 2", 2 1/2", 3", 4", 6"
Connections	NPT, Flanged
Body Material	Cast Iron
PMO Max. Operating Pressure	250 PSIG (Steam)
TMO Max. Operating Temperature	422° F



TYPICAL APPLICATIONS

The **WSVI** Safety Valves are used for over-pressure protection on unfired pressure vessels in saturated steam systems.

HOW IT WORKS

As safety valves open on a non-compressible fluid application, the disc lifts directly proportional to the increase in system pressure over the valve set point. Safety valves not only provide over pressure protection resulting from thermal expansion of liquids, but will respond with a rapid full opening "pop" action on systems which contain or generate steam air or gas.

FEATURES

- Stainless Steel wetted trim nozzle & disc
- Metal to metal seating, lapped to optimum flatness
- Two control rings assure maximum performance & adjustability

SAMPLE SPECIFICATION

Safety valves shall be high capacity design with cast iron construction featuring rust-proof steel stems, springs, washers and metal-to-metal lapped seats. Units shall be qualified to the ASME Boiler Code Section VIII and suitable for steam service.

DIMENSIONS & WEIGHTS – inches / pounds

Model No.	Valve Size Inlet x Outlet	Orifice Size	A	B	C	Hex Flat D	Weight (lbs)
WSVI-16F-18S-J	1 1/2" 250# x 2 1/2" FNPT	J	15	4	4.31		35
WSVI-17F-19S-K	2" 250# x 3" FNPT	K	16	4	4.63		36
WSVI-17S-19S-K	2" FNPT x 3" FNPT	K	16	4	4.63	3.75	37
WSVI-18F-19S-K	2 1/2" 250# x 3" FNPT	K	16	4	4.63		41
WSVI-19F-19S-K	3" 250# x 3" FNPT	K	16	4	4.63		45
WSVI-18F-20S-L	2 1/2" 250# x 4" FNPT	L	22	5.13	5.63		84
WSVI-18S-20S-L	2 1/2" FNPT x 4" FNPT	L	22	5.13	5.63	5.38	81
WSVI-19F-20S-L	3" 250# x 4" FNPT	L	22	5.13	5.63		85
WSVI-20F-20S-L	4" 250# x 4" FNPT	L	22	5.13	5.63		90
WSVI-19S-20S-M	3" FNPT x 4" FNPT	M	22	5.13	5.63	5.38	80
WSVI-19F-20S-M	3" 250# x 4" FNPT	M	22	5.13	5.63		87
WSVI-20F-20S-M	4" 250# x 4" FNPT	M	22	5.13	5.63		95
WSVI-20F-22F-N	4" 250# x 6" 125#	N	28	7.25	6.75		210
WSVI-20F-22F-P	4" 250# x 6" 125#	P	28	7.25	6.75		215
WSVI-22F-23F-Q	6" 250# x 8" 125#	Q	42	10	9.25		530
WSVI-22F-23F-R	6" 250# x 8" 125#	R	42	10	9.25		530

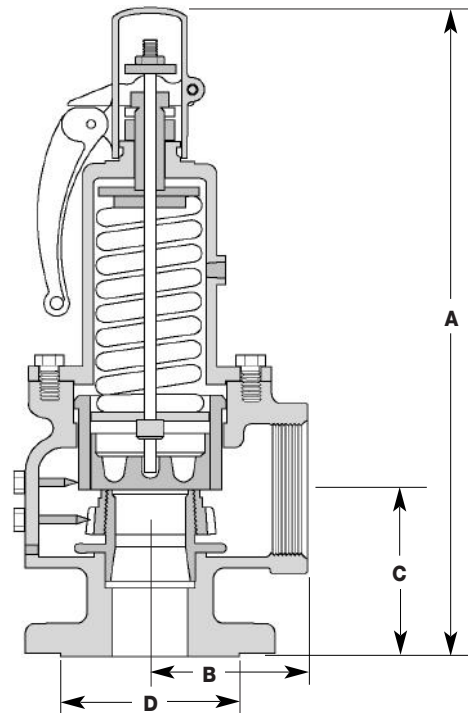

MATERIALS

Body	Cast Iron
Guide Ring	Brass
Disc	SST
Stem	Steel-Plated

SPECIALTY PRODUCTS

SPECIALTY PRODUCTS

WSVI Series

Safety Relief Valves "UV" Steam-ASME Section VIII Pressure Vessels

CAPACITIES – Pounds of saturated steam per hour (lbs/hr)

Set Pressure (PSIG)	Orifice Letter / Area in Square Inches							
	"J" = 1.358	"K" = 1.926	"L" = 2.990	"M" = 3.774	"N" = 4.550	"P" = 6.692	"Q" = 11.593	"R" = 16.798
15	2008	2848	4421	5580	6728	9895	17141	24820
20	2315	3283	5097	6433	7756	11408	19762	28615
25	2622	3719	5773	7287	8785	12921	22383	32410
30	2929	4154	6449	8140	9814	14434	25004	36205
35	3267	4633	7193	9079	10945	16098	27887	40379
40	3604	5112	7936	10017	12077	17762	30771	44554
45	3942	5591	8680	10956	13208	19426	33654	48729
50	4280	6070	9423	11894	14340	21091	36537	52903
55	4618	6549	10167	12833	15471	22755	39420	57078
60	4955	7028	10911	13771	16603	24419	42303	61252
65	5293	7507	11654	14710	17735	26083	45186	65427
70	5631	7986	12398	15649	18866	27748	48069	69601
75	5969	8465	13141	16587	19998	29412	50952	73776
80	6306	8944	13885	17526	21129	31076	53835	77951
85	6644	9423	14629	18464	22261	32740	56719	82125
90	6982	9902	15372	19403	23392	34405	59602	86300
95	7319	10381	16116	20341	24524	36069	62485	90474
100	7657	10860	16859	21280	25655	37733	65368	94649
105	7995	11339	17603	22218	26787	39397	68251	98823
110	8333	11818	18346	23157	27919	41062	71134	102998
115	8670	12297	19090	24096	29050	42726	74017	107173
120	9008	12776	19834	25034	30182	44390	76900	111347
125	9346	13255	20577	25973	31313	46055	79783	115522
130	9684	13734	21321	26911	32445	47719	82666	119696
135	10021	14213	22064	27850	33576	49383	85550	123871
140	10359	14692	22808	28788	34708	51047	88433	128045
145	10697	15171	23552	29727	35839	52712	91316	132220
150	11034	15650	24295	30666	36971	54376	94199	136395
155	11372	16129	25039	31604	38103	56040	97082	140569
160	11710	16608	25782	32543	39234	57704	99965	144744
165	12048	17087	26526	33481	40366	59369	102848	148918
170	12385	17566	27270	34420	41497	61033	105731	153093
175	12723	18045	28013	35358	42629	62697	108614	157267
180	13061	18524	28757	36297	43760	64361	111497	161442
185	13399	19003	29500	37236	44892	66026	114381	165617
190	13736	19482	30244	38174	46023	67690	117264	169791
195	14074	19961	30988	39113	47155	69354	120147	173966
200	14412	20440	31731	40051	48287	71018	123030	178140
205	14749	20919	32475	40990	49418	72683	125913	182315
210	15087	21398	33218	41928	50550	74347	128796	186489
215	15425	21876	33962	42867	51681	76011	131679	190664
220	15763	22355	34706	43806	52813	77675	134562	194839
225	16100	22834	35449	44744	53944	79340	137445	199013
230	16438	23313	36193	45683	55076	81004	140329	203188
235	16776	23792	36936	46621	56207	82668	143212	207362
240	17113	24271	37680	47560	57339	84332	146095	211537
245	17451	24750	38424	48498	58471	85997	148978	215711
250	17789	25229	39167	49437	59602	87661	151861	219886
Approx. 1 PSI incr.	68	96	149	188	226	333	577	835

Notes: 1) Ratings are 90% of actual capacity. 2) For Set Pressures over 250 PSIG, consult factory. 3) For other sizes, consult factory.
 4) ASME Section I – Steam Boilers – pounds of saturated steam per hour @ 3% or 2 PSIG accumulation (whichever is greater).
 5) ASME Section VIII – Pressure Vessels – pounds of saturated steam per hour @ 10 % or 3 PSIG accumulation (whichever is greater).

SPECIALTY PRODUCTS

SPECIALTY PRODUCTS

WCIY Series

Cast Iron Y-Type Strainers

Watson McDaniel reserves the right to change the designs and/or materials of its products without notice.
©2010 Watson McDaniel Company

Model	WCIY
Sizes	1/2", 3/4", 1", 1 1/4", 1 1/2", 2", 2 1/2", 3", 4"
Connections	NPT, Flanged
Body Material	Cast Iron



PRESSURE/TEMPERATURE RATINGS

NPT	250 PSIG @ 406°F - Steam
NPT	400 PSIG @ 150°F - WOG
125# FLG	125 PSIG @ 450°F - Steam
125# FLG	200 PSIG @ 150°F - WOG
250# FLG	250 PSIG @ 450°F - Steam
250# FLG	500 PSIG @ 150°F - WOG

Note: WOG = Water, Oil or Gas.



FLOW

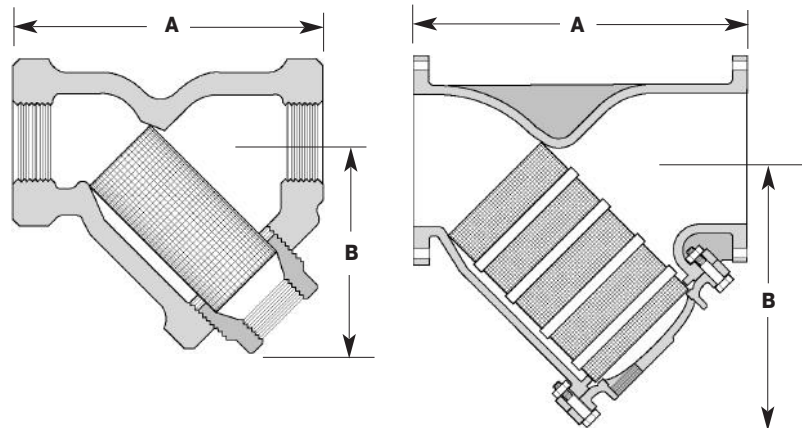

TYPICAL APPLICATIONS

The WCIY Y-Strainer is used to strain dirt particles from fluid in pipelines and provide inexpensive protection for costly pumps, meters, valves, traps, turbines and compressors.

FEATURES

- Machined seat assures perfect fit for screen
- Blowdown connection & easily removable stainless steel cylindrical screens for easy maintenance
- Durable cast iron body

INSTALLATION

The strainer should be installed in the flow direction as indicated on the body in either a vertical down or horizontal pipeline. The strainer must be accessible for periodic cleaning.

DIMENSIONS & WEIGHTS – inches / pounds

Size/Connection	Model	A	B	Blowdown NPT	Weight (lbs)	Screen Opening
1/2" NPT	WCIY-12-020S250	3 ³ / ₁₆	2 ¹ / ₁₆	3/8	1.5	0.033
3/4" NPT	WCIY-13-020S250	3 ³ / ₄	2 ⁷ / ₁₆	3/8	2.5	0.033
1" NPT	WCIY-14-020S250	4	2 ⁷ / ₁₆	3/4	3	0.033
1 1/4" NPT	WCIY-15-020S250	5	3 ³ / ₈	3/4	5.5	0.033
1 1/2" NPT	WCIY-16-020S250	5 ³ / ₄	3 ⁷ / ₈	1	8	0.033
2" NPT	WCIY-17-020S250	7	4 ³ / ₄	1 1/2	13	0.033
2" 125# FLG	WCIY-17-020F125	8 ⁷ / ₈	6	1/2	22	0.033
2" 250# FLG	WCIY-17-020F250	8 ⁷ / ₈	6 ¹ / ₂	1/2	28	0.033
2 1/2" NPT	WCIY-18-045S250	9 ¹ / ₄	5 ⁷ / ₈	1 1/2	22	0.045
2 1/2" 125# FLG	WCIY-18-045F125	10 ³ / ₄	8	1	35	0.045
2 1/2" 250# FLG	WCIY-18-045F250	11 ¹ / ₄	7	1	38	0.045
3" NPT	WCIY-19-045S250	10	6	1 1/2	30	0.045
3" 125# FLG	WCIY-19-045F125	11 ¹ / ₂	8 ³ / ₄	1	43	0.045
3" 250# FLG	WCIY-19-045F250	11 ⁵ / ₈	8	1	54	0.045
4" 125# FLG	WCIY-20-045F125	13 ⁷ / ₈	9 ¹ / ₂	1 1/4	75	0.045
4" 250# FLG	WCIY-20-045F250	14 ¹ / ₂	10 ³ / ₄	1	110	0.125

MATERIALS

Body	Cast Iron, A126 CLASS B
Plug	Cast Iron, A126 CLASS B
Cover	Cast Iron, A126 CLASS B
*Screen	Stainless Steel
*Gasket	Blue Guard

*Recommended spare parts.

SPECIALTY PRODUCTS

WCSY/WSSY Series

Y-Type Strainers - Carbon Steel/Stainless Steel

Model	WCSY, WSSY
Sizes	1/2", 3/4", 1", 1 1/4", 1 1/2", 2"
Connections	NPT, SW
Body Material	Carbon Steel (WCSY) Stainless Steel (WSSY)

PRESSURE/TEMPERATURE RATINGS

Carbon Steel	NPT	600 PSIG @ 839°F
Stainless Steel	NPT	600 PSIG @ 1124°F

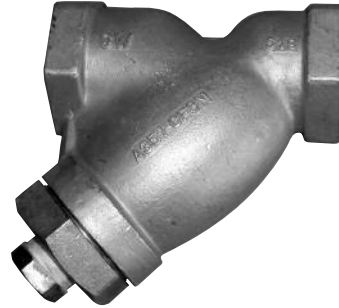

TYPICAL APPLICATION

The **WCSY/WSSY** Y-Strainers are used to strain dirt particles from fluid in pipelines and provide inexpensive protection for costly pumps, meters, valves, traps, turbines and compressors.

FEATURES

- Machined seat assures perfect fit for screen
- Blowdown connection & easily removable stainless steel cylindrical screens for easy maintenance
- Choice of carbon steel or stainless steel bodies

INSTALLATION

The strainer should be installed in the flow direction as indicated on the body in either a vertical down or horizontal pipeline. The strainer must be accessible for periodic cleaning.

MATERIALS

WCSY CARBON STEEL MODEL

Body	Carbon Steel, A216 GR WCB
Plug	Carbon Steel, A216 GR WCB
Cover	Carbon Steel, A216 GR WCB
Screen	Stainless Steel
Gasket	Blue Guard

WSSY STAINLESS STEEL MODEL

Body	Stainless Steel, A351 GR CF8M
Plug	Stainless Steel, A351 GR CF8M
Cover	Stainless Steel, A351 GR CF8M
Screen	Stainless Steel
Gasket	Blue Guard

HOW TO ORDER

Specify connection size and connection configuration (NPT or SW) that will meet application requirements.

DIMENSIONS & WEIGHTS – inches / pounds

Size NPT	A	B	Blowdown NPT	Weight (lbs)	Screen Opening
1/2"	3	2 ⁷ / ₁₆	1/4	2	0.033
3/4"	3 ³ / ₄	2 ¹⁵ / ₁₆	3/8	3	0.033
1"	4 ⁵ / ₈	3 ³ / ₄	3/8	5	0.033
1 1/4"	5	4	3/4	7	0.033
1 1/2"	5 ⁵ / ₈	4 ¹³ / ₁₆	3/4	10	0.033
2"	7	6 ¹ / ₈	1	15	0.045

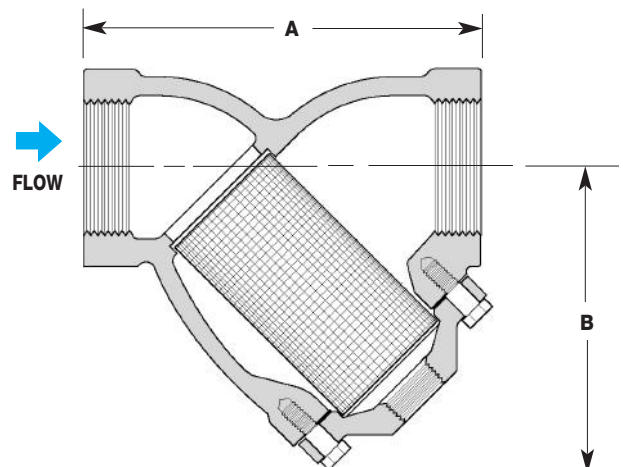

SPECIALTY PRODUCTS

Suction/Mixing Tee

Cast Iron, Bronze or Stainless Steel

Watson McDaniel reserves the right to change the designs and/or materials of its products without notice.
©2010 Watson McDaniel Company

Model	Suction Tee	
Sizes	1/2", 3/4", 1", 1 1/4", 1 1/2", 2", 2 1/2", 3"	
Connections	NPT	
Body Material	Cast Iron	125# & 250#
	Bronze	250#
	Stainless Steel	300#

PRESSURE/TEMPERATURE RATINGS

Cast Iron	NPT	250 PSIG @ 406°F
Bronze	NPT	300 PSIG @ 422°F
Stainless Steel	NPT	450 PSIG @ 400°F



TYPICAL APPLICATIONS

The Watson McDaniel Cast Iron, Bronze or Stainless Steel **Suction Tee** is a specialized type of pipe fitting used for blending, agitation, recirculation, mixing, aeration and heating.

HOW IT WORKS

Heating by Direct Steam Injection: When using a Suction Tee for heating by direct steam injection, the Suction Tee must be completely submerged in the liquid being heated. When steam enters the primary inlet side of the Suction Tee, a low pressure condition is created inside the Suction Tee body. This causes the liquid inside the tank to circulate through the suction tee and intermix with the steam causing the liquid to be heated.

Mixing: When liquid is pumped through the primary inlet of a Suction Tee, a low pressure region is created inside the Suction Tee body. When a Suction Tee is submerged, the liquid inside the tank will circulate through the secondary inlet of the Suction Tee causing a mixing action to occur. An alternate method when mixing two different liquids is to pump one liquid through the primary inlet and the other liquid through the secondary inlet of the Suction Tee.

Aeration: A tank or reservoir of liquid can be aerated by connecting the secondary inlet of the Suction Tee to an air or gas line under pressure while pumping liquid through the primary inlet.

FEATURES

- Available in cast iron, bronze or stainless steel
- No moving parts
- Quiet operation
- Replaces mixing pumps, propellers & other mechanical devices

INSTALLATION

Installation should include a strainer and isolation valves for maintenance purposes.

MAINTENANCE

Watson McDaniel Suction Tee will operate for extended periods of time and requires no maintenance.

MATERIALS

CAST IRON MODEL	
Body	Cast Iron, A126 CLASS 30
Plug	Cast Iron, A126 CLASS 30
BRONZE MODEL	
Body	Bronze, ASTM B-62
Plug	Brass
STAINLESS STEEL MODEL	
Body	Stainless Steel, A351 GR CF8M
Plug	Stainless Steel, A351 GR 316

SPECIALTY PRODUCTS

Suction/Mixing Tee

Cast Iron, Bronze or Stainless Steel

DIMENSIONS & WEIGHTS – inches / pounds

Pipe Size	A	B	C	D	E	Weight (lbs)
125# Cast Iron Body & Bronze 250#						
1/2"	3 ³ / ₄	1 ¹ / ₂	2 ¹ / ₄	1 ³ / ₄	1/4	1.5
3/4"	5	1 ⁷ / ₈	3 ¹ / ₈	3 ¹ / ₈	3/8	3.25
1"	5 ⁵ / ₈	2 ³ / ₁₆	3 ⁷ / ₁₆	2 ¹ / ₂	5/8	4
1 ¹ / ₄ "	5 ³ / ₄	2 ¹ / ₄	3 ¹ / ₂	2 ¹ / ₂	11/16	4.75
1 ¹ / ₂ "	6 ¹ / ₁₆	2 ⁷ / ₁₆	3 ⁵ / ₈	2 ⁷ / ₈	7/8	5.50
2"	7	2 ⁷ / ₈	4 ¹ / ₈	3	15/16	7
2 ¹ / ₂ "	8 ³ / ₈	3 ¹ / ₂	4 ⁷ / ₈	3 ⁵ / ₁₆	1	11.75
3"	9 ¹ / ₂	4 ¹ / ₈	5 ³ / ₈	3 ⁷ / ₈	1 ⁵ / ₁₆	20.50
250# Cast Iron Body & Stainless Steel 300#						
1"	6 ¹ / ₁₆	2 ⁵ / ₁₆	3 ³ / ₄	2 ¹¹ / ₁₆	11/16	6.75
1 ¹ / ₄ "	6 ³ / ₁₆	2 ³ / ₈	3 ¹³ / ₁₆	2 ¹³ / ₁₆	11/16	8
1 ¹ / ₂ "	6 ¹ / ₂	2 ¹³ / ₁₆	3 ¹¹ / ₁₆	2 ⁷ / ₈	7/8	10.50
2"	7 ³ / ₈	3 ¹ / ₁₆	4 ⁵ / ₁₆	3 ¹ / ₄	15/16	16.50

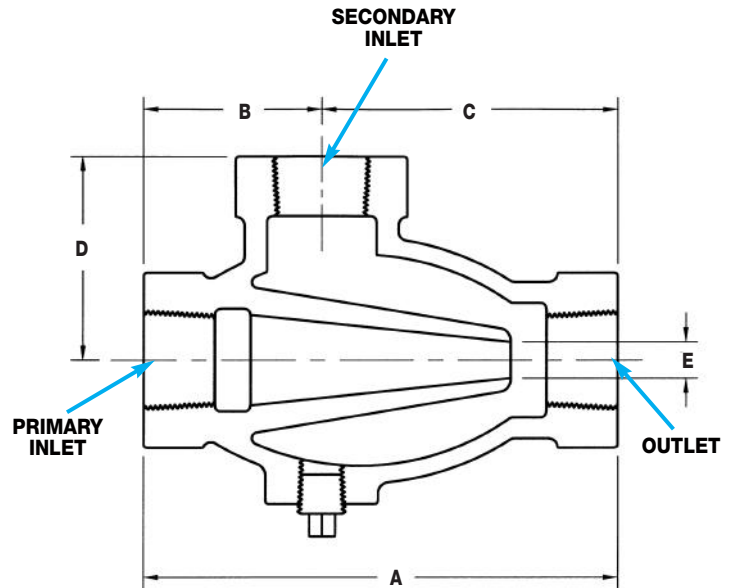

CAPACITIES – Steam (lbs/hr)

Size	Supply Pressure (PSIG)																	
	5	10	15	20	25	30	35	40	45	50	55	60	65	75	85	100	125	150
1/2"	66	96	114	135	156	165	174	207	240	258	276	294	312	354	396	456	552	630
3/4"	108	138	168	198	228	255	282	309	336	363	390	402	414	504	564	648	792	936
1"	312	390	468	549	630	711	792	882	972	1026	1080	1170	1260	1428	1584	1800	2232	2556
1 ¹ / ₄ "	444	558	672	783	894	1005	1116	1230	1344	1461	1578	1689	1800	2010	2232	2592	3168	3708
1 ¹ / ₂ "	612	756	900	1026	1152	1332	1512	1674	1836	1980	2124	2286	2448	2772	3060	3528	4320	5040
2"	798	1008	1206	1410	1614	1815	2016	2214	2412	2610	2808	3024	3240	3636	3996	4680	5652	6696
2 ¹ / ₂ "	912	1152	1368	1584	1800	2052	2304	2538	2772	2997	3222	3447	3672	4140	4608	5292	6480	7560
3"	1332	1656	1980	2304	2628	2970	3312	3636	3960	4302	4644	4986	5328	5976	6600	7620	9300	10800

APPLICATIONS

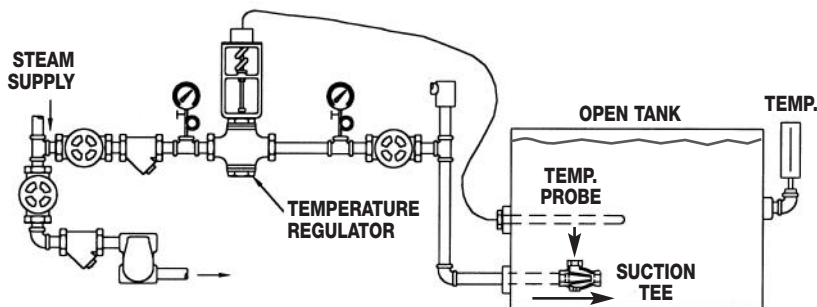

Controlling temperature of large open tank by steam injection

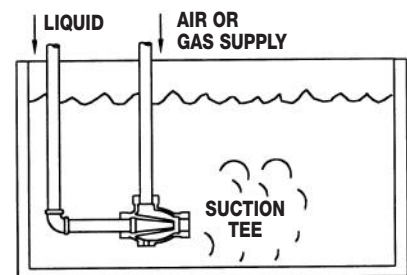

Aeration or Agitation

SPECIALTY PRODUCTS

SPECIALTY PRODUCTS

Ejectors

Syphons, Eductors, Exhausters & Injectors

Watson McDaniel reserves the right to change the designs and/or materials of its products without notice.
©2010 Watson McDaniel Company

Model	W-EJECT, W-ELL, W-LM
Sizes	1/2" - 2"
Connections	NPT
Body Material	Bronze (1/2" - 1 1/2") Cast Iron (2")
PMO Max. Operating Pressure	100 PSIG
TMO Max. Operating Temperature	130°F
PMA Max. Allowable Pressure	250 PSIG up to 450°F
TMA Max. Allowable Temperature	450°F @ 250 PSIG

Note: Minimum Operating Pressure for W-ELL & W-LM is 20 PSIG.



W-ELL & W-LM



W-EJECT

TYPICAL APPLICATIONS

Watson McDaniel **Ejectors** perform a variety of functions depending on the application and motive fluid (steam or water) used. See performance charts on the following pages. Applications include: exhausting, agitating, aerating, circulating, pumping and mixing.

HOW IT WORKS

Using water, steam or air pressure as the motive force, ejectors operate on the principle that a high velocity flow through a nozzle will create a pressure drop in the area around the nozzle discharge. The resulting vacuum will induce flow into the secondary inlet of the ejector.

FEATURES

- No moving parts
- Can be used with water or steam pressure
- Submersible
- Available in cast iron or bronze

SAMPLE SPECIFICATION

Ejectors shall be constructed from bronze or cast iron. Units shall be capable of using steam, water or air as a motive force.

INSTALLATION

See installation examples on following page.

MATERIALS

Body (1/2" - 1 1/2")	Bronze
Body (2")	Cast Iron
Nozzles (all sizes)	Bronze

Note: W-ELL & W-LM for liquid motive service only.

SPECIALTY PRODUCTS

Ejectors

Syphons, Eductors, Exhausters & Injectors

W-EJECT

DIMENSIONS – inches

Size	Connection Sizes *			Dimensions			
	S. Inlet	Discharge	P. Inlet	A	B	C	D
Bronze Body & Nozzles							
1/2"	1/2	1/2	1/4	3 1/4	17/16	1 13/16	1 1/8
3/4"	3/4	3/4	3/8	4	1 1/2	2 1/2	1 3/8
1"	1	1	1/2	5 1/8	2 1/4	2 7/8	1 5/8
1 1/4"	1 1/4	1 1/4	3/4	5 7/8	2 7/16	3 7/16	1 13/16
1 1/2"	1 1/2	1 1/2	3/4	6 1/4	2 11/16	3 9/16	1 15/16

Cast Iron Body with Bronze Nozzles

2"	2	2	1	7 1/4	3 3/8	4 1/8	2 3/8
----	---	---	---	-------	-------	-------	-------

* Connections are female NPT.

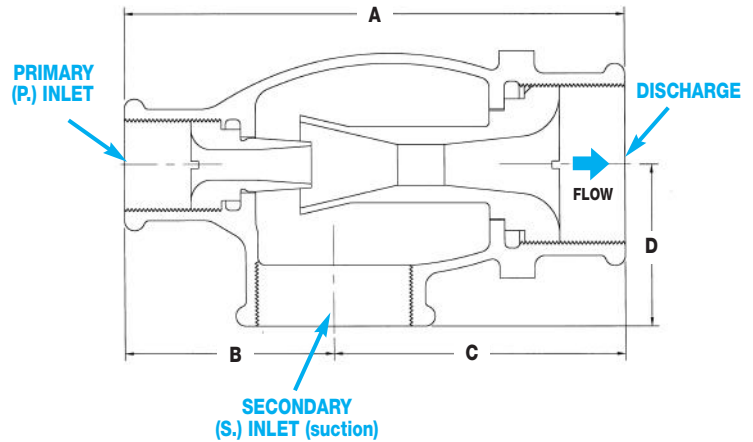

W-ELL / W-LM

Bronze Body & Nozzles

DIMENSIONS – inches

Size	Connection Sizes **			Dimensions		
	S. Inlet	Discharge	P. Inlet	A	B	D
3/4"	3/4	3/4	1/2	5 13/16	2	1 3/8
1"	1	1	3/4	7 1/8	2 5/16	1 3/4
1 1/4"	1 1/4	1 1/4	1	9	2 7/16	2 1/8

** Connections are male NPT.

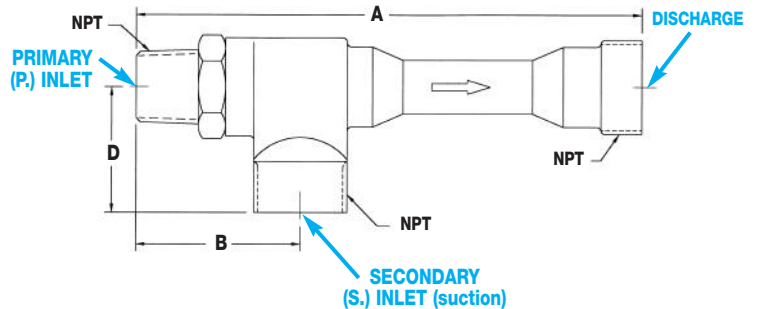

Ejectors shown Pumping Liquid

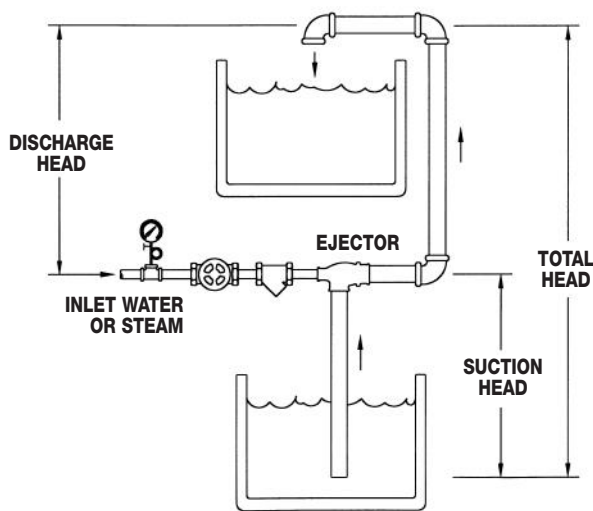

It is always desirable to keep the Ejector as close to the actual liquid being pumped as possible. The maximum height the liquid can be pumped depends on the pressure of the "motive" liquid or steam available. Please refer to the capacity graphs for maximum flow rates and maximum achievable heads.

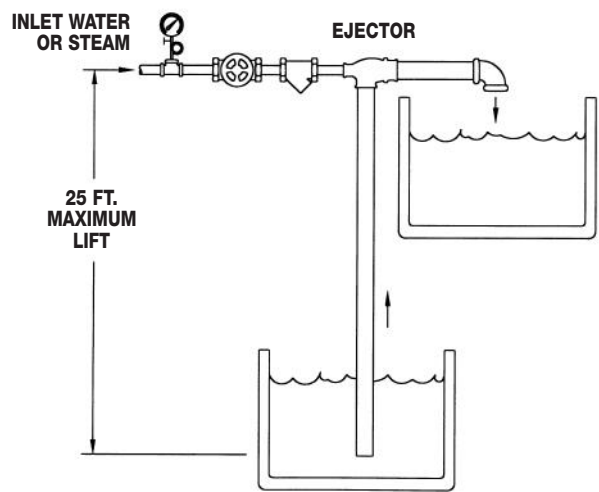

The maximum height that water or any liquid with a specific gravity of 1 can be lifted is 25 feet. Increases in the temperature of the liquid being lifted will cause this maximum height to decrease. Pumping liquids in excess of 130°F is not recommended. Please consult factory with any specific application.

Ejector Sizing

Watson McDaniel reserves the right to change the designs and/or materials of its products without notice.
©2010 Watson McDaniel Company

Example 1

A #14 1" Ejector using 60 lbs. of water pressure as a motive force will pump water to a maximum height of 40 ft. When pumping water to a height of 20 ft. using 60 lbs. of water pressure, the amount of water being pumped is 700 gal/hr.

Example 2

A #14 1" Ejector using 60 lbs. of steam pressure as a motive force will pump water to a maximum height of 60 ft. When pumping water to a height of 53 ft. using 60 lbs. of steam pressure, the amount of water being pumped is 650 gal/hr.

#12 (1/2") Water Ejector

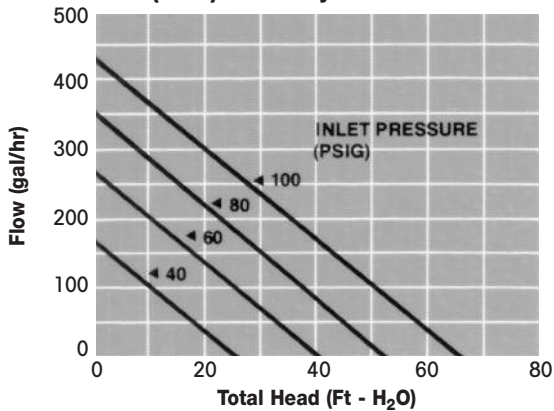

#12 (1/2") Steam Ejector

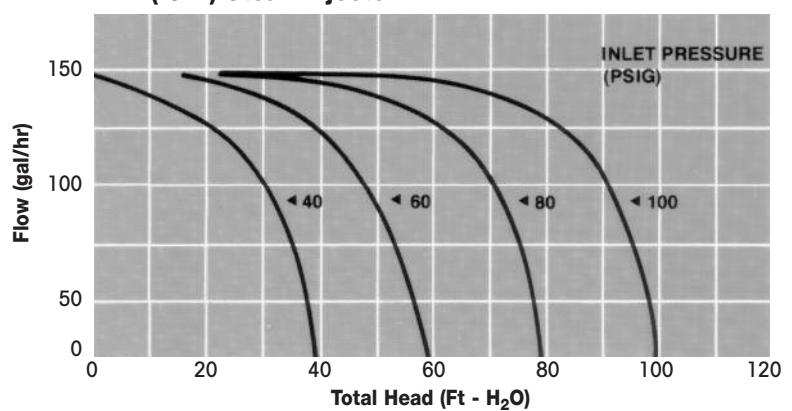

#13 (3/4") Water Ejector

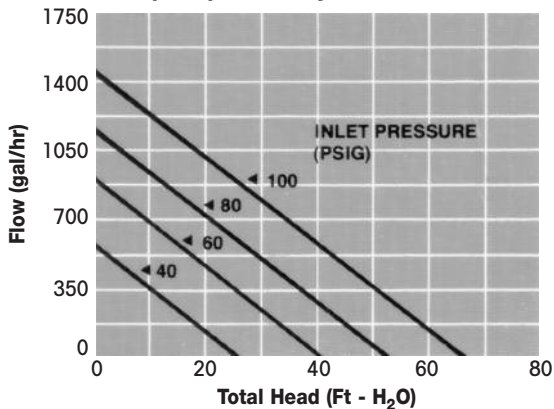

#13 (3/4") Steam Ejector

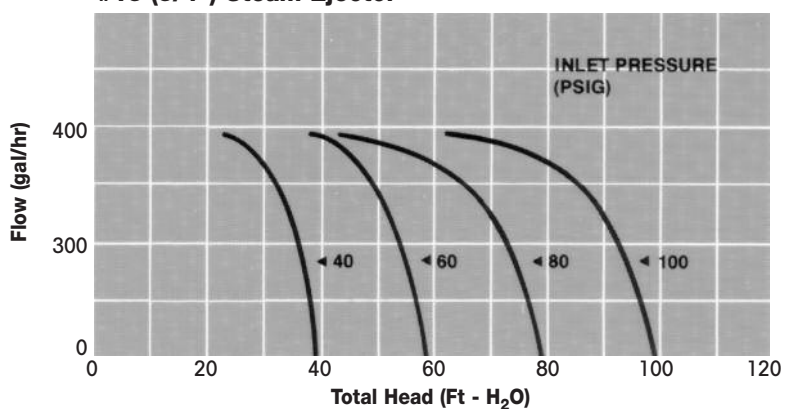

#14 (1") Water Ejector

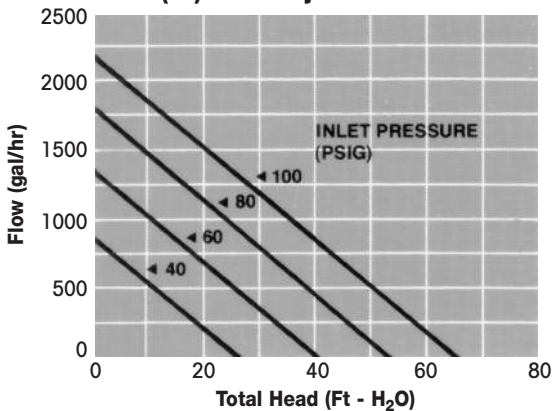

#14 (1") Steam Ejector

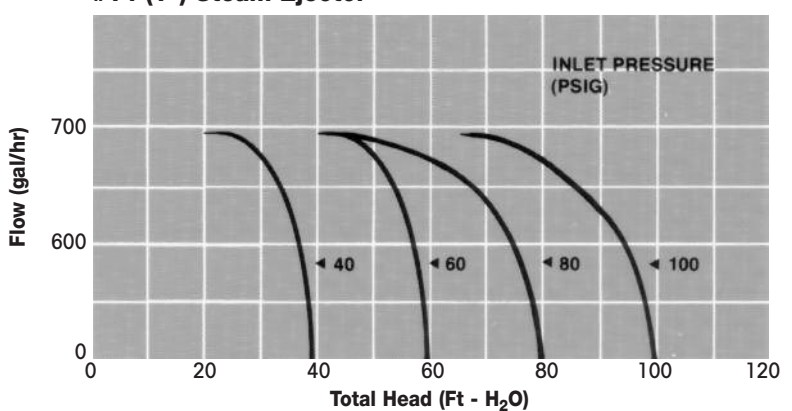

Ejector Sizing

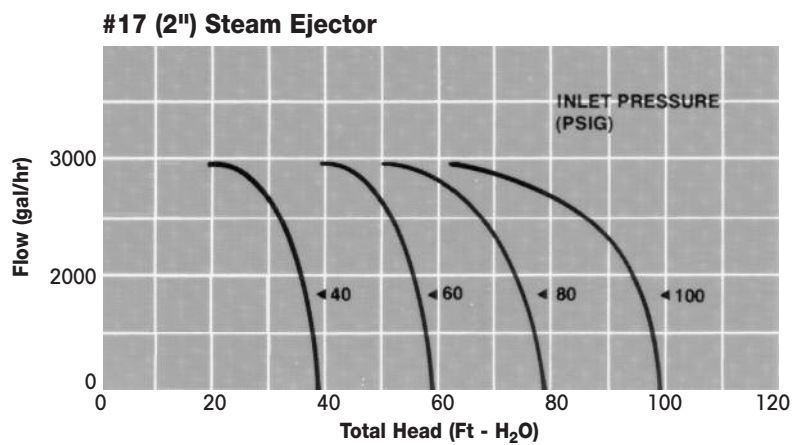
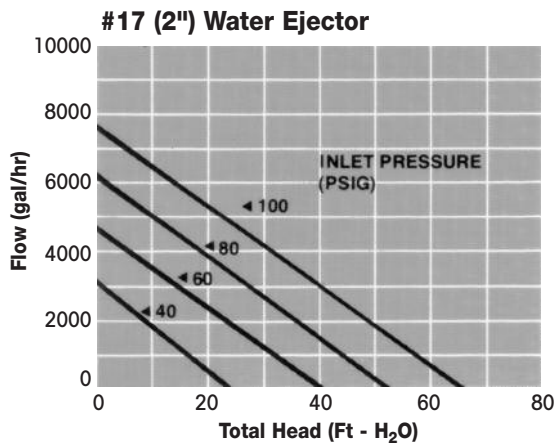
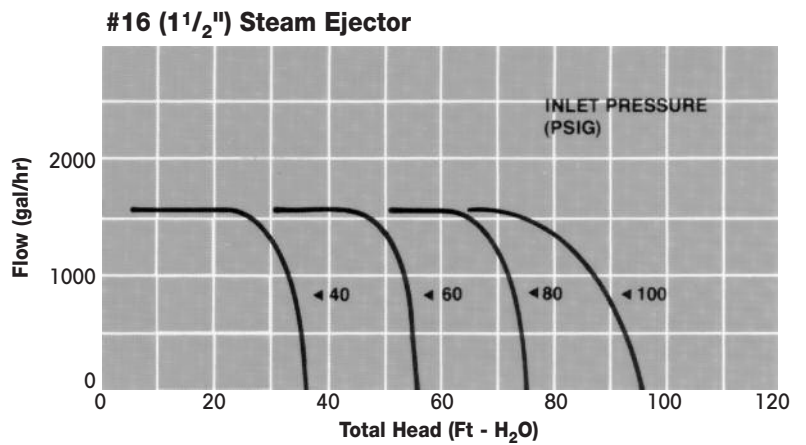
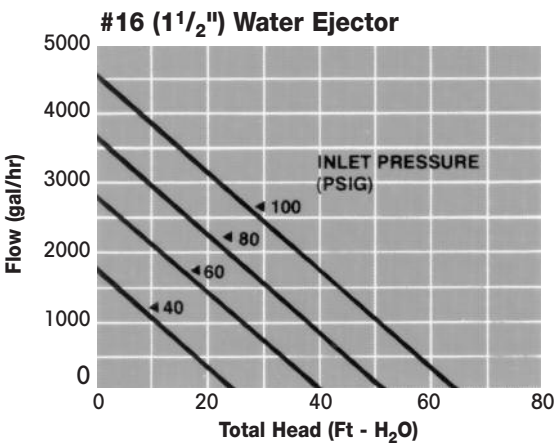
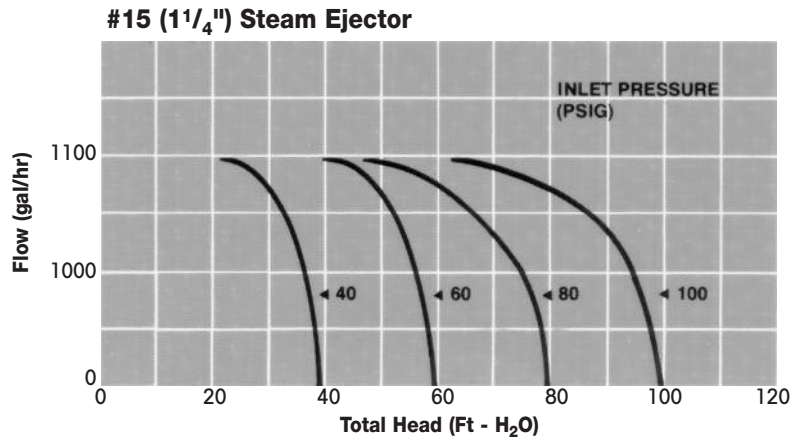
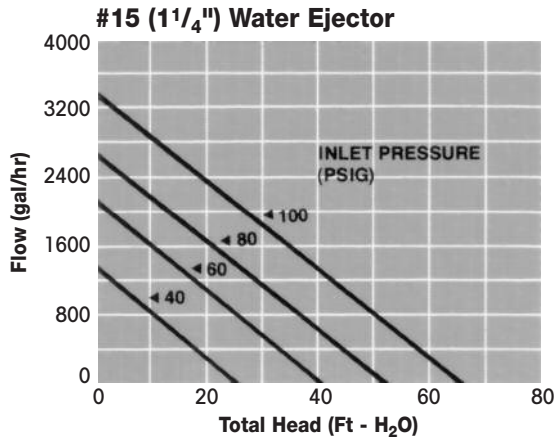

SPECIALTY
PRODUCTS

SPECIALTY PRODUCTS

AV813W

Air Eliminator

Watson McDaniel reserves the right to change the designs and/or materials of its products without notice.
©2010 Watson McDaniel Company

Model	AV813W
Sizes	3/4"
Connections	NPT
Body Material	Cast Iron
PMO Max. Operating Pressure	150 PSIG
TMO Max. Operating Temperature	300°F
PMA Max. Allowable Pressure	150 PSIG up to 350°F
TMA Max. Allowable Temperature	353°F @ 150 PSIG



TYPICAL APPLICATIONS

The **AV813W** Air Eliminator is used for the removal of air and other gases from vessels or piping systems without allowing the contained liquid to escape.

HOW IT WORKS

The valve and seat assembly inside the air eliminator is connected to a stainless steel float. When there is no liquid in the body of the air eliminator, the float will be in the down position allowing air or other gases in the vessel or piping system to escape. When liquid enters the body, it will lift the float and the valve will be closed off before any liquid can escape.

FEATURES

- Rugged cast iron housing
- Simple design for easy maintenance
- Stainless steel internals
- Optional Viton Valve Head for high temperatures & tight shut-off

SAMPLE SPECIFICATION

Air Eliminator shall be of cast iron construction with stainless steel internals and soft EPDM seat for tight shut-off. Optional Viton seat is available for elevated temperatures and tight shut-off.

INSTALLATION & MAINTENANCE

The AV813W should be located at a high point in the system or vessel. The unit must be installed level and upright with flow upward for the float mechanism to operate properly. Isolation valves should be installed for ease of maintenance.

MATERIALS

Cover	Cast Iron, ASTM A-126, Class B
Body	Cast Iron, ASTM A-126, Class B
Gasket	Grafoil
Seat Yoke	Stainless Steel, Type 304
Valve Seat	Stainless Steel, Type 304
Pivot Pin	Stainless Steel, Type 304
Valve Head	EPDM (Viton optional)
Lever	Stainless Steel, Type 304
Float	Stainless Steel, Type 304
Washer	Stainless Steel, Type 304
Screw & Washer	Stainless Steel, Type 304

DIMENSIONS – inches

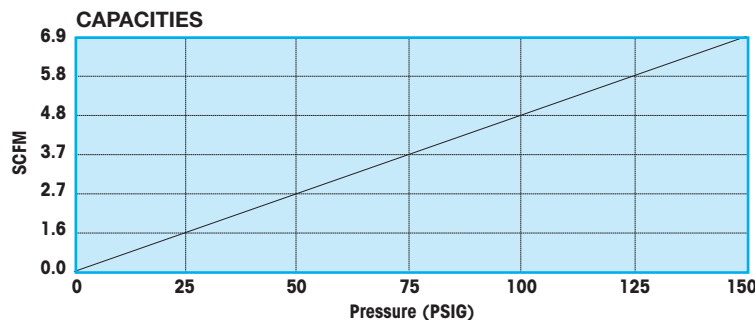
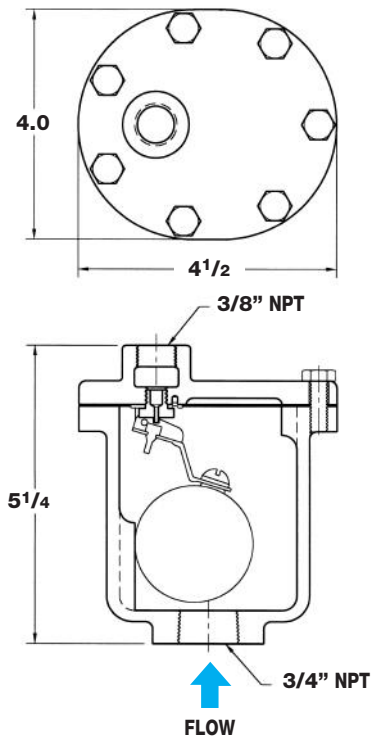

SPECIALTY PRODUCTS

AE1800/1800R Series

Air Eliminator

Model	AE1800, AE1800R
Sizes	1/2", 3/4"
Connections	NPT
Body Material	Stainless Steel
PMO Max. Operating Pressure	400 PSIG
TMO Max. Operating Temperature	500°F
PMA Max. Allowable Pressure	400 PSIG up to 500°F
TMA Max. Allowable Temperature	500°F @ 400 PSIG



TYPICAL APPLICATION

The **AE1800** Air Eliminator is used for the removal of air and other gases from vessels or piping systems without allowing the contained liquid to escape.

HOW IT WORKS

The valve and seat assembly inside the air eliminator is connected to a stainless steel float. When there is no liquid in the body of the air eliminator, the float will be in the down position allowing air or other gases in the vessel or piping system to escape. When liquid enters the body, it will lift the float and the valve will be closed off before any liquid can escape.

FEATURES

- All stainless steel body & internals
- Hardened SST seat (55 Rc) for longer service life
- Repairable units available (AE1800R Series)

INSTALLATION & MAINTENANCE

The AE1800 should be located at a high point in the system or vessel. The unit must be installed level and upright with flow upward for the float mechanism to operate properly. Isolation valves should be installed for ease of maintenance.

DIMENSIONS – inches / pounds

Model & Orifice Size			Size (Inlet x Outlet)	Height A	Weight (lbs)
.078"	.101"	.125"			
AE1811	AE1821	AE1831	3/4" x 1/2"	7.5	4
AE1811R	AE1821R	AE1831R		7.9	5
AE1812	AE1822	AE1832		3/4" x 3/4"	7.5
AE1812R	AE1822R	AE1832R	7.9		5
AE1813	AE1823	AE1833	1/2" x 1/2"		7.5
AE1813R	AE1823R	AE1833R		7.9	5

MATERIALS

Body & Shell	Stainless Steel, AISI 304
Float Assembly	Stainless Steel, AISI 304
Valve & Lever Assembly	Hardened Stainless Steel, 55 Rc
Seat	Stainless Steel, AISI 420
Washer, Seat	302 SS
*Gasket	Grafoil
*Bolt, Hex, HD	Stainless Steel, AISI 316
*Nut	Stainless Steel, 18-8

* AE1800R Repairable models only.

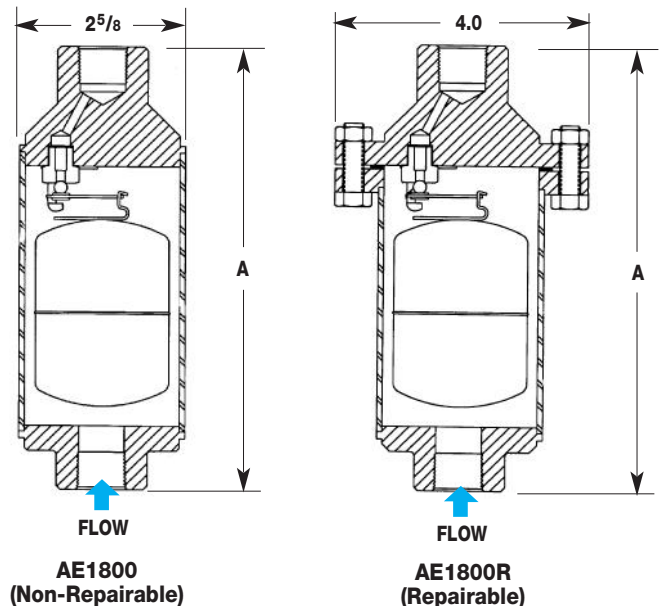

CAPACITIES – Air (SCFM)

Series	Orifice Size	PMO* (PSIG)	Inlet Pressure (PSIG)																						
			5	7	9	12	15	20	25	30	40	50	60	70	80	90	100	110	120	125	150	180	265	300	400
AE1810	.078"	400	1.0	1.1	1.3	1.5	1.7	1.9	2.2	2.5	3.1	3.4	3.7	4.2	5.4	6.0	6.8	7.2	7.5	7.9	9.4	11.2	16.3	18.4	24.4
AE1820	.101"	265	1.7	1.9	2.1	2.4	2.6	3.1	3.5	4.0	4.8	5.3	5.7	6.6	8.4	9.3	10.2	11.1	12	12.4	14.5	17.3	24.8	-	-
AE1830	.125"	180	2.5	3.0	3.4	3.9	4.3	5.1	5.8	6.5	8.0	8.7	9.5	10.9	13.9	15.4	16.9	18.4	19.9	20.5	24.4	29.6	-	-	-

Note: Specify Model Number when ordering. Example: **AE1812R** (.078" Orifice, 3/4" x 3/4", 400 PSIG max, Repairable unit)

* PMO based on liquids with specific gravity of 1. Consult factory for PMO for liquids of other specific gravity values.

SPECIALTY PRODUCTS

AV2000C

Thermostatic Air Vent

Watson McDaniel reserves the right to change the designs and/or materials of its products without notice.
©2010 Watson McDaniel Company

Model	AV2000C
Sizes	1/2", 3/4"
Connections	NPT
Body Material	Stainless Steel
PMO Max. Operating Pressure	650 PSIG
TMO Max. Operating Temperature	Saturated Steam Temp.
PMA Max. Allowable Pressure	1032 PSIG @ 100°F
TMA Max. Allowable Temperature	750°F @ 800 PSIG



TYPICAL APPLICATIONS

The **AV2000C** is used on industrial steam applications up to 650 PSIG for the removal of air and non-condensable gases from process equipment, vessels and piping.

HOW IT WORKS

The thermostatic air vent contains a welded stainless steel thermal element that expands when heated and contracts when cooled. When air and non-condensable gases are present, the valve is in the open discharge position. When steam reaches the air vent, the element expands and closes the valve off tightly.

FEATURES

- Welded stainless steel thermal element
- Hardened stainless steel seat and valve plugs for extended service life
- Integral strainer to protect from contamination
- Steam pressures up to 650 PSIG
- Special Subcool Options Available

SAMPLE SPECIFICATION

Air Vent shall have a thermal element operation with a seal-welded tamper-proof stainless steel construction. All internals shall be stainless steel, featuring an integral strainer and hardened seating system.

INSTALLATION

The air vent should be located at a high point in the system or vessel. The air vent can be installed in any orientation. An isolation valve should be installed to facilitate removal and replacement without system shut-down. Unit is seal-welded and non-repairable.

MATERIALS

Housing	Stainless Steel, ASTM A351-CF3
Thermal Element	Stainless Steel
Valve & Seat	Hardened Stainless Steel, 40 Rc
Strainer Screen .033" perf.	Stainless Steel

HOW TO ORDER

Specify model, pipe size and orifice size. If orifice size is not specified, the standard 5/16" diameter will be used.

DIMENSIONS – inches

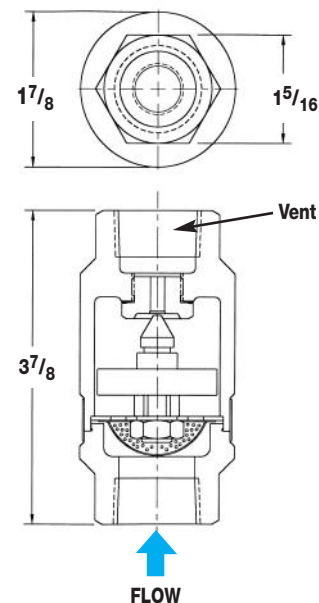

CAPACITIES – Air (SCFM)

Model	Orifice Size	PMO (PSIG)	Inlet Pressure (PSIG)																	
			2	5	10	25	50	100	125	150	200	250	300	350	400	450	500	550	600	650
AV2001C	3/16"	650	5.2	6.2	7.7	12.4	20.2	35.9	43.9	51.5	67.2	82.8	98.5	114	130	145	161	177	192	208
AV2003C	5/16"	650	10.7	12.6	15.8	25.4	41.4	73.3	89.4	105	137	169	201	233	265	297	329	361	393	425

SPECIALTY PRODUCTS

AVT125

Thermostatic Air Vent

Model	AVT125
Sizes	1/2", 3/4"
Connections	NPT
Body Material	Forged Brass
PMO Max. Operating Pressure	125 PSIG
TMO Max. Operating Temperature	353°F
PMA Max. Allowable Pressure	125 PSIG up to 450°F
TMA Max. Allowable Temperature	450°F @ 125 PSIG

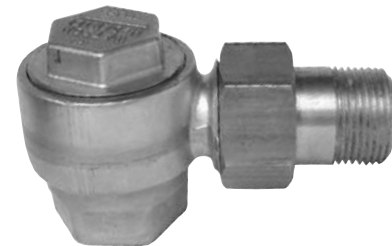

TYPICAL APPLICATIONS

The **AVT125** is used on steam applications up to 125 PSIG for removal of air and non-condensable gases from process equipment, vessels and piping.

HOW IT WORKS

The thermostatic air vent contains a welded stainless steel thermal element that expands when heated and contracts when cooled. When air and non-condensable gases are present, the valve is in the open discharge position. When steam reaches the air vent, the element expands and closes the valve off tightly.

FEATURES

- Simple design for easy maintenance
- All Stainless Steel Internals
- Thermal element is the only moving part

SAMPLE SPECIFICATION

Air Vent shall have a stainless steel thermal element operation with forged brass construction, featuring a union nipple inlet connection. The valve and seat shall be stainless steel.

INSTALLATION & MAINTENANCE

The AVT125 should be located at a high point in the system or vessel. The air vent can be installed in any orientation. An isolation valve should be installed to facilitate repair without system shut-down. Unit is in-line repairable. Repair kits are available.

MATERIALS

Body & Cover	Forged Brass, CA 377
Element	Welded Stainless Steel, AISI 302
Spring	Stainless Steel, AISI 304
Seat	Stainless Steel, AISI 303
Gasket	Brass, ASTM B-21
Union Nipple	Brass, ASTM B-16
Union Nut	Brass, ASTM B-16

CAPACITIES – Air (SCFM)

Size	Orifice Size	Inlet Pressure (PSIG)					
		5	10	25	50	100	125
1/2"	.25"	9	13	22	37	65	80
3/4"	.30"	12	16	27	46	82	100

DIMENSIONS & WEIGHTS – inches / pounds

Size	A	B	C	D	Weight
1/2"	2 ¹³ / ₁₆	1 ³ / ₁₆	1	2 ¹ / ₈	2.75
3/4"	3 ¹ / ₁₆	1 ³ / ₁₆	1	2 ¹ / ₈	2.75

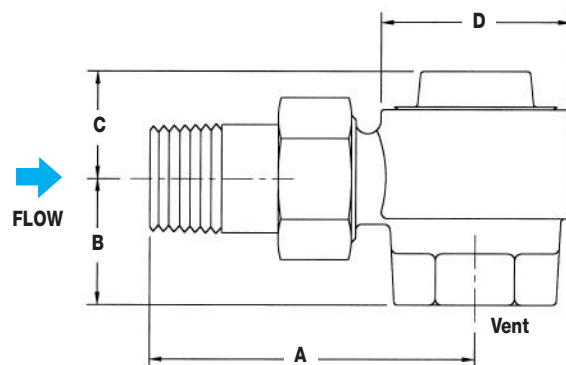

SPECIALTY PRODUCTS

WDS Series

Air/Steam Moisture Separator

Watson McDaniel reserves the right to change the designs and/or materials of its products without notice.
©2010 Watson McDaniel Company

Model	WDS	
Body Material	Cast Iron	Carbon Steel
Sizes	3/4", 1", 1 1/4", 1 1/2", 2", 2 1/2", 3", 4"	1", 1 1/4", 1 1/2", 2", 2 1/2", 3", 4", 5", 6", 8", 10", 12"
Connections	NPT, 125# Flanged	NPT, SW, 150# & 300# Flanged
PMO Max. Operating Pressure	250 PSIG	300 PSIG (NPT & SW)
Pressure/ Temperature Rating	NPT: 250 PSIG @ 450°F 125# FLG: 150 PSIG @ 450°F	NPT, SW: 1000 PSIG @ 650°F 150# FLG: 150 PSIG @ 450°F 300# FLG: 500 PSIG @ 650°F

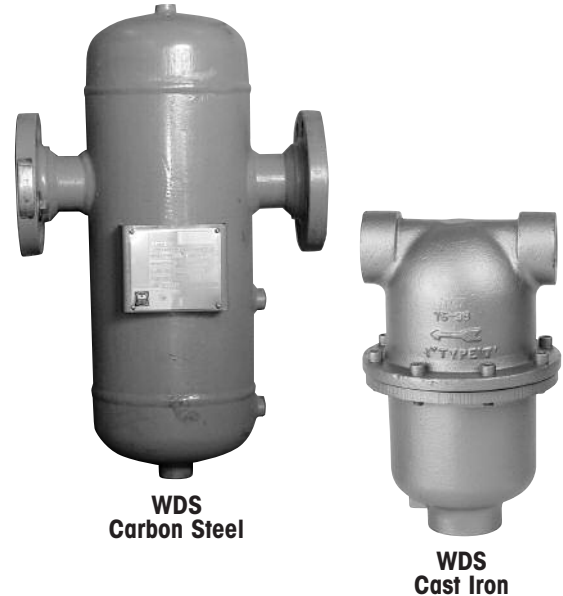

TYPICAL APPLICATIONS

The **WDS Series** Separators are used for the removal of entrained liquid or solids from steam. Effective in applications where the system has an entrained liquid flow rate of up to 40% by weight of the unit's flow capacity.

HOW IT WORKS

Moisture-laden steam enters the inlet of the separator where it is deflected in a centrifugal downward motion. The entrained moisture is separated out by reduction in velocity. Separated liquid then falls below the Vortex Containment Plate where it cannot be re-entrained. Dry, clean steam then flows upward and exits through the outlet of the separator.

FEATURES

- High efficiency: 99% of all particles 10 microns and larger
- Minimum pressure drop
- Gauge ports on 3" & 4" cast iron units
- Standard gauge ports on 2 1/2"-12" carbon steel units
- ASME Code constructed

SAMPLE SPECIFICATION

Steam Moisture Separator shall be "T" style for horizontal piping installations. Separator to be code constructed in cast iron or carbon steel and available in FNPT and flanged connections.

INSTALLATION

The WDS Steam Moisture Separator must be installed in a horizontal run of pipe. Exercise standard piping and structural practices when installing this unit. Proper drainage of the separator utilizing a float & thermostatic steam trap is essential for proper operation.

MATERIALS

WDS Cast Iron Model	All Parts Cast Iron
WDS Carbon Steel Model	All Parts Fabricated Carbon Steel

CAPACITIES – Steam (lbs/hr)

Size	Operating Pressure (PSIG)											
	5	10	25	50	100	150	200	250	300	400*	450*	500*
3/4", 1"	192	219	289	384	536	661	772	872	964	1132	1210	1284
1 1/4"	305	348	459	609	851	1050	1225	1384	1531	1797	1921	2038
1 1/2"	434	495	653	868	1211	1495	1744	1970	2179	2559	2734	2902
2"	769	877	1156	1536	2143	2646	3087	3487	3857	4529	4839	5136
2 1/2"	1220	1391	1834	2437	3401	4199	4900	5535	6121	7188	7680	8151
3"	1912	2181	2876	3821	5333	6583	7682	8677	9597	11269	12041	12779
4"	3183	3632	4787	6362	8878	10959	12788	14446	15977	18760	20046	21274
5"	4823	5501	7252	9637	13449	16603	19373	21884	24203	28420	30367	32229
6"	7465	8516	11226	14917	20818	25699	29988	33874	37464	43992	47006	49887
8"	12444	14196	18713	24867	34704	42840	49989	56468	62452	73334	78359	83161
10"	19376	22104	29137	38720	54036	66705	77836	87924	97241	114186	122009	129487
12"	28560	32580	42947	57071	79648	98320	114728	129597	143331	168306	179836	190859

* Not to be used for steam service at these pressures. For air service only.

SPECIALTY PRODUCTS

WDS Series

Air/Steam Moisture Separator

CAST IRON

WDS CAST IRON NPT MODEL DIMENSIONS – inches / pounds

Size (NPT)	A	B	C	Vent NPT	Drain NPT	Gauge Centers G	Weight (lbs)
3/4"	5 1/2	10 1/8	5 3/4	1/4	3/4	N/A	23
1"	6	10 1/8	6 3/4	1/4	1	N/A	26
1 1/4"	6	10 3/8	7	1/4	1	N/A	30
1 1/2"	7 1/4	13 1/8	8 1/8	1/4	1	N/A	45
2"	8 1/8	15 5/8	8 1/2	1/4	1	N/A	50
2 1/2"	12	18 1/4	11 3/8	1/4	1 1/4	N/A	95
3"	11	18 1/4	11 3/8	1/4	1 1/4	3 1/2	90

WDS CAST IRON FLANGED MODEL DIMENSIONS – inches / pounds

Size (Flanged)	A	B	C	Vent NPT	Drain NPT	Gauge Centers G	Weight (lbs)
2"	10 1/2	13 3/4	8 1/2	1/4	1	N/A	50
3"	14	16	11 3/8	1/4	1 1/4	4 3/4	95
4"	15 7/8	19 3/8	14	1/4	1 1/4	5 3/4	195

CAST IRON WDS

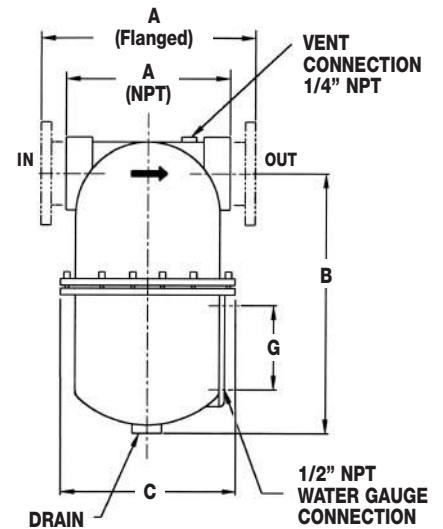

CARBON STEEL

WDS CARBON STEEL MODEL DIMENSIONS – inches / pounds

Size	NPT & SW		150# & 300# FLG		Gauge Centers G	NPT Drain		Weight (lbs)			
	A	A	B	C		D	Std.	Opt.	NPT & SW	150# FLG	300# FLG
1"	6 3/8	10 1/2	10 1/2	12	5 9/16	Opt.	1	1 1/2	29	33	35
1 1/4"	6 3/8	10 1/2	10 1/2	12	5 9/16	Opt.	1	1 1/2	30	35	37
1 1/2"	7 5/8	11 1/2	12 1/2	14	6 5/8	Opt.	1	2	55	50	56
2"	7 7/8	11 1/2	12 1/2	14	6 5/8	Opt.	1	2	57	55	59
2 1/2"	–	16	15	22	8 5/8	5 3/4	1	2	–	100	110
3"	–	18	18	26	10 3/4	5 3/4	1 1/2	2 1/2	–	140	150
4"	–	20	22	31	12 3/4	5 3/4	1 1/2	2 1/2	–	195	220
5"	–	22	26	36	14	7 7/8	1 1/2	2 1/2	–	230	290
6"	–	24	30	41	16	7 7/8	1 1/2	2 1/2	–	350	380
8"	–	28	37	50	18	7 7/8	2	3	–	475	610
10"	–	34	55	70	24	7 7/8	2	3	–	780	1180
12"	–	38	58	75	28	7 7/8	2 1/2	4	–	940	1510

Note: 1" - 2" units are Cast Steel; 2 1/2" and up are Fabricated Steel.

CARBON STEEL WDS

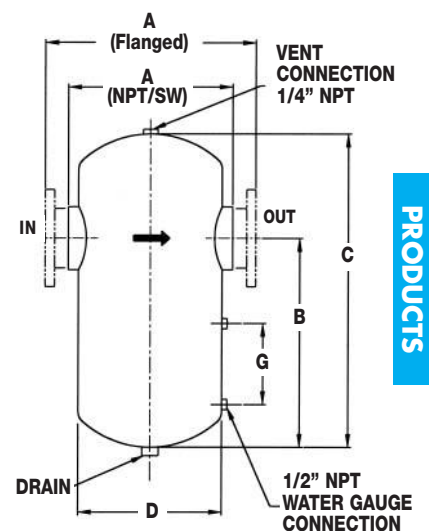

SPECIALTY PRODUCTS

SPECIALTY PRODUCTS

WCIS Series

Air/Steam Moisture Separator

Watson McDaniel reserves the right to change the designs and/or materials of its products without notice.
©2010 Watson McDaniel Company

Model	WCIS1	WCIS2	WCIS3
Sizes	3/4", 1"	1 1/2", 2"	2" to 4"
Connections	NPT	NPT	ANSI 125#
Body Material	Cast Iron	Cast Iron	
PMO Max. Operating Pressure	200 PSIG	145 PSIG	
TMO Max. Operating Temperature	388°F	363°F	
PMA Max. Allowable Pressure	232 PSIG @ 0-248°F 160 PSIG @ 572°F	232 PSIG @ 0-248°F 188 PSIG @ 428°F	
TMA Max. Allowable Temperature	572°F @ 160 PSIG	428°F @ 0-188 PSIG	

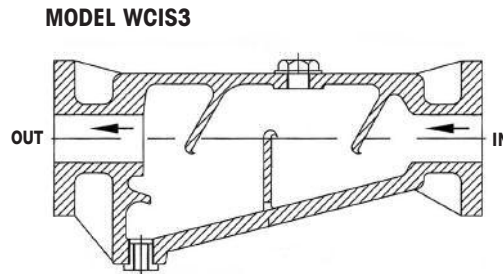
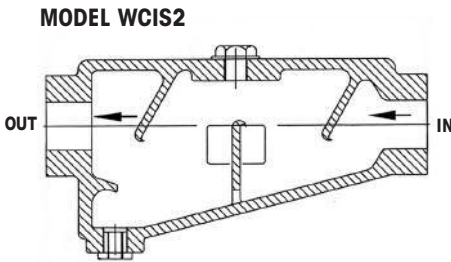
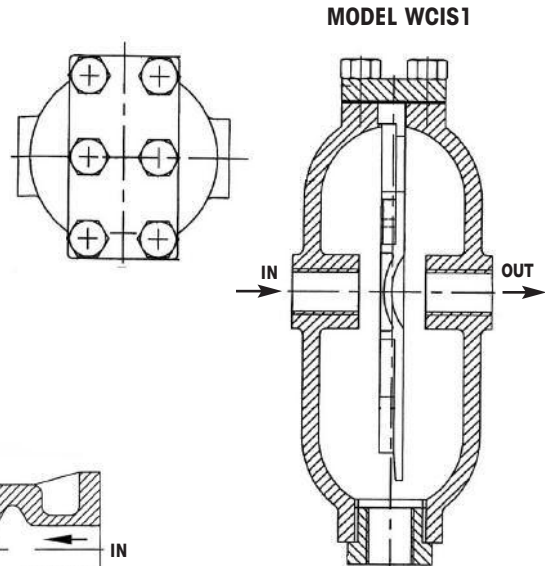

TYPICAL APPLICATIONS

- On steam mains, as a drip station ahead of steam pressure reducing or temperature control valves
- On the steam inlet to laundry presses and other process equipment which require dry saturated steam
- On the compressed air supply to sensitive instruments and before filters

HOW IT WORKS

When a vapor entrained with moisture enters the steam separator, a series of baffles change its flow direction several times. During the process, the baffles in the housing collect impinging water droplets that are carried in the vapor. Gravity causes the accumulated water droplets and other foreign particles to fall to the drain and exit through an external trap. This allows clean, dry vapor to exit at the outlet of the separator.

FEATURES

- Extracts nearly all moisture and solids > 10 microns
- Optimal gravity discharge
- Long-lasting cast iron construction

SAMPLE SPECIFICATION

Moisture Separator shall be of the high efficiency impingement type having a pressure drop that does not exceed an equivalent length of pipe. Body shall be iron with threaded or flanged connections. A threaded bottom drain shall be provided for the installation of a trap to discharge any accumulated liquid.

INSTALLATION

Install a horizontal pipeline with the drain directly below the line. Recommended trap is a continuous draining float operated type.

MAINTENANCE

The trap at the separator drain should be serviced periodically according to the manufacturer's instructions. The separator itself requires no maintenance.

MATERIALS

WCIS1 Body & Cover	Cast Iron ASTM A 126 GR CLB
WCIS2/3 Body	
WCIS1 Gasket	Semi-rigid Graphite Laminate
WCIS2/3 Gasket	Reinforced Exfoliated Graphite
Bolts	Steel UNF, BS 1766 Gr 5
Bushing	Malleable Iron
Plug	Malleable Iron

SPECIALTY PRODUCTS

WCIS Series

Air/Steam Moisture Separator

MODEL WCIS2

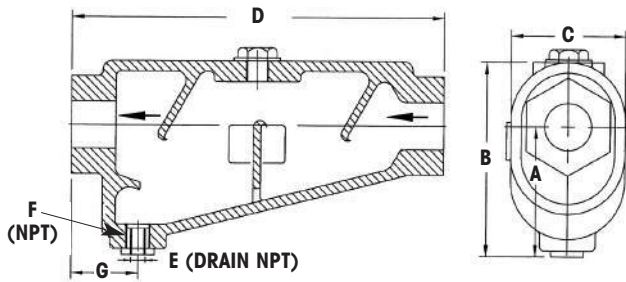

MODEL WCIS3

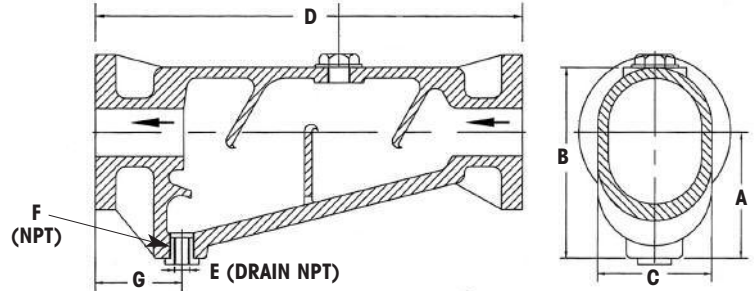

WCIS2 DIMENSIONS with threaded connections - in./mm

Size	A	B	C	D	E	F	G	Weight
1 1/2"	4 11/16 119	6 1/2 165	3 1/2 89	12 304	1/2" -	1 1/2" -	2 3/8 60	24 lb 11 kg
2"	5 15/16 150	8 1/4 210	4 1/2 115	15 11/16 398	1/2" -	1 1/2" -	2 7/8 73	42.0 lb 19 kg

WCIS3 DIMENSIONS with flanged connections - in./mm

Size	A	B	C	D	E	F	G	Weight
2"	5 3/8 137	8 1/8 207	4 13/16 122	18 457	1/2" -	1 1/2" -	3 3/4 94	67 lb 30.5 kg
2 1/2"	6 3/4 172	9 5/8 244	5 3/4 147	15 15/16 404	3/4" -	1 1/2" -	3 7/8 98	67 lb 30.5 kg
3"	6 3/4 172	10 254	6 1/8 155	19 1/16 484	1" -	1 1/2" -	3 7/8 98	86 lb 39 kg
4"	9 7/16 233	13 3/8 337	7 13/16 197	27 1/4 692	1" -	1 1/2" -	4 13/16 122	172 lb 78 kg

MODEL WCIS1

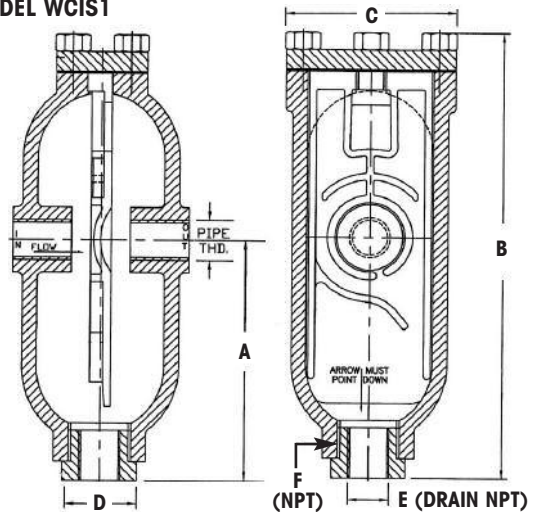

WCIS1 DIMENSIONS (nominal) - inches/mm

Size	A	B	C	D	E	F	Weight
3/4"	6 1/16 155	10 1/4 260	4 7/16 112	4 7/16 112	1/2" -	1 1/2" -	15 lb 7 kg
1"	9 229	15 1/4 388	5 7/8 149	6 1/16 155	1/2" -	2" -	30 lb 14 kg

Recommended Air Capacities in SCFM

Size	Operating Pressure (PSIG)						
	20	40	60	80	100	145	200
3/4"	31	51	67	87	102	148	194
1"	51	82	108	138	169	245	322
1 1/2"	123	190	262	334	406	587	
2"	206	437	437	556	674	968	
2 1/2"	288	623	623	793	957	1380	
3"	370	803	803	1019	1236	1776	
4"	643	1385	1385	1756	2132	3059	

Recommended Saturated Steam Capacities in lbs/hr

Size	Operating Pressure (PSIG)						
	5	10	25	50	100	145	200
3/4"	68	82	128	203	349	496	635
1"	110	133	208	330	567	804	1030
1 1/2"	260	317	494	783	1347	1845	
2"	429	523	814	1292	3220	3041	
2 1/2"	612	746	1162	1844	3168	4340	
3"	946	1153	1795	2848	4893	6702	
4"	1630	1985	3092	4906	8427	11542	

SPECIALTY PRODUCTS

WEH Series

Exhaust Head

Watson McDaniel reserves the right to change the designs and/or materials of its products without notice.
©2010 Watson McDaniel Company

Model	WEHC	WEHF	WEHFSS
Sizes	1", 1 1/2", 2", 2 1/2", 3", 4", 5", 6", 8", 10"	2 1/2", 3", 4", 5", 6", 8", 10"	
Connections	NPT, 125# Flanged	150# Flanged	
Body Material	Cast Iron	Carbon Steel	Stainless Steel



TYPICAL APPLICATIONS

The **WEH Series** Exhaust Heads are used to separate entrained water and particles from steam prior to being discharged directly to the atmosphere. Typically used to eliminate water damage to rooftops and other equipment.

HOW IT WORKS

Exhaust heads use the cyclonic effect where the velocity of the steam is used to generate centrifugal motion that whirls the steam and throws the entrained water to the wall of the unit where it is released to a drain below. Correct sizing of exhaust heads for steam service is important in order to assure the highest possible desiccation of the steam.

FEATURES

- Up to 99% of particles 10 microns and larger are separated from discharging steam
- Maximizes separation of water and steam
- Contains Vortex Containment Plate

SAMPLE SPECIFICATION

Steam Exhaust Head shall be a cyclone design for vertical venting to atmosphere. Unit shall have a vortex containment plate feature to prevent re-entrainment of liquid. Exhaust Head to be constructed in cast iron, carbon steel or stainless steel and available in FNPT and flanged connections.

INSTALLATION

The WEH Steam Exhaust Head must be installed at the top of a vertical vent pipe. Exercise standard piping and structural practices when installing this unit. Proper drainage of the exhaust head is essential for proper operation. Pipe the drain connection of the exhaust head to a roof gutter or down spout.

MATERIALS

WEHC	All Parts Cast Iron
WEHF	All Parts Fabricated Carbon Steel
WEHFSS	All Parts Fabricated Stainless Steel

HOW TO ORDER

Refer to the capacity chart to determine which model is required to satisfy the application requirements.

Available sizes & connections:

Cast Iron

NPT - 1", 1 1/2", 2", 2 1/2", 3", 4"
125# Flanged - 4", 5", 6", 8", 10"

Carbon Steel & Stainless Steel

150# Flanged - 2 1/2", 3", 4", 5", 6", 8", 10"

SPECIALTY PRODUCTS

WEH Series

Exhaust Head

WEHC (Cast Iron)

WEHC DIMENSIONS (inches), WEIGHTS & CAPACITIES

Size	Inlet Connection	A	B	Drain NPT	Weight (lbs)	Capacity*
1"	NPT	5 ¹ / ₄	6 ¹ / ₈	1/2	11	160
1 ¹ / ₂ "	NPT	5 ¹ / ₄	6 ¹ / ₈	1/2	11	370
2" & 2 ¹ / ₂ "	NPT	7 ¹ / ₂	8 ⁷ / ₈	3/4	25	1,000
3"	NPT	8 ³ / ₄	11 ¹ / ₄	3/4	40	2,100
4"	NPT	10	11 ⁷ / ₈	1	50	2,700
4"	125# FLG	10	15	1	68	2,700
5"	125# FLG	13	14	1 ¹ / ₂	90	4,000
6"	125# FLG	14 ³ / ₄	18 ³ / ₄	1 ¹ / ₂	115	6,000
8"	125# FLG	18	20	2	190	10,500
10"	125# FLG	23	24	2	335	16,000

* Capacity in pounds of exhaust steam per hour at atmospheric pressure of 14.7 PSIA.

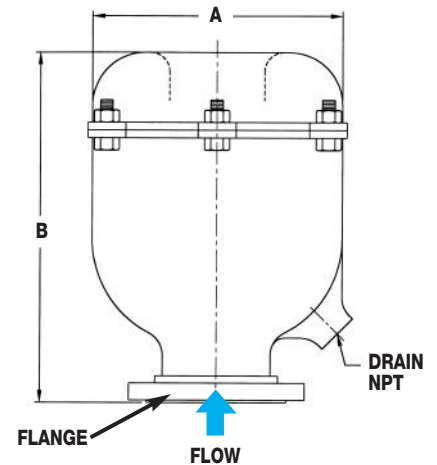
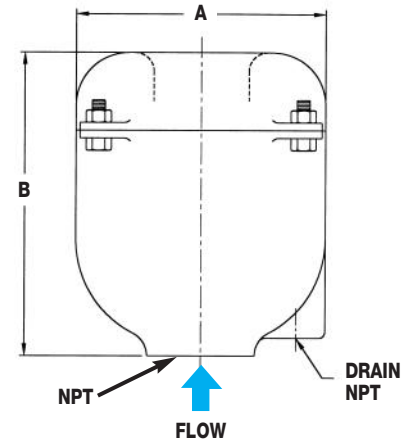

WEHF (Carbon Steel) & WEHFSS (Stainless Steel)

WEHF/SS DIMENSIONS (inches), WEIGHTS & CAPACITIES

Inlet Size	Inlet Connection	A	B	Drain NPT	Weight (lbs)	Capacity*
2 ¹ / ₂ "	150# FLG	8 ⁵ / ₈	16	1	55	1,000
3"	150# FLG	10 ³ / ₄	19	1 ¹ / ₂	65	1,600
4"	150# FLG	14	24	1 ¹ / ₂	100	2,700
5"	150# FLG	16	26	1 ¹ / ₂	130	4,000
6"	150# FLG	18	30	1 ¹ / ₂	140	6,000
8"	150# FLG	20	36	2	240	10,500
10"	150# FLG	24	42	2	390	16,000

* Capacity in pounds of exhaust steam per hour at atmospheric pressure of 14.7 PSIA.

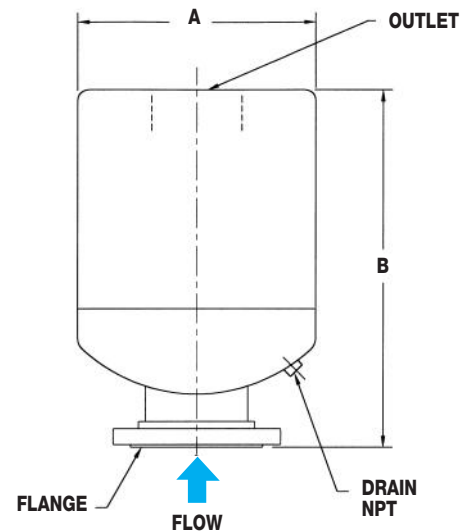

SPECIALTY PRODUCTS

SPECIALTY PRODUCTS

WVBSS

Stainless Steel Vacuum Breaker

Watson McDaniel reserves the right to change the designs and/or materials of its products without notice.
©2010 Watson McDaniel Company

Model	WVBSS
Sizes	1/2"
Connections	NPT
Body Material	Stainless Steel
PMO Max. Operating Pressure	300 PSIG
TMO Max. Operating Temperature	752°F
PMA Max. Allowable Pressure	300 PSIG up to 752°F
TMA Max. Allowable Temperature	752°F @ 300 PSIG



TYPICAL APPLICATIONS

The **WVBSS** Vacuum Breaker is used on heat exchangers, air coils, jacketed kettles, pressing machines, boiler feed water tanks, sparge systems, water lines or anywhere else an unwanted vacuum may occur. The WVBSS allows air to enter the steam or liquid system in order to "break the vacuum" caused by the condensing of steam or draining of liquid from a system. The elimination of vacuum is necessary to allow proper drainage of liquid from process systems.

HOW IT WORKS

The Vacuum Breaker functions like a simple check valve. Outside air is allowed to enter the system through the air inlet. However, when steam or water try to escape, the vacuum breaker closes off tightly.

FEATURES

- All stainless steel construction
- Small & compact

SAMPLE SPECIFICATION

Vacuum Breakers shall be of all stainless steel construction with a hardened stainless steel ball valve design.

INSTALLATION

Unit must be installed in a vertical position and should be placed at the highest point in the system.

MATERIALS

Body	Stainless Steel, Series 300
Ball	Hardened Stainless Steel
Nameplate	Stainless Steel, Series 300

DIMENSIONS – inches

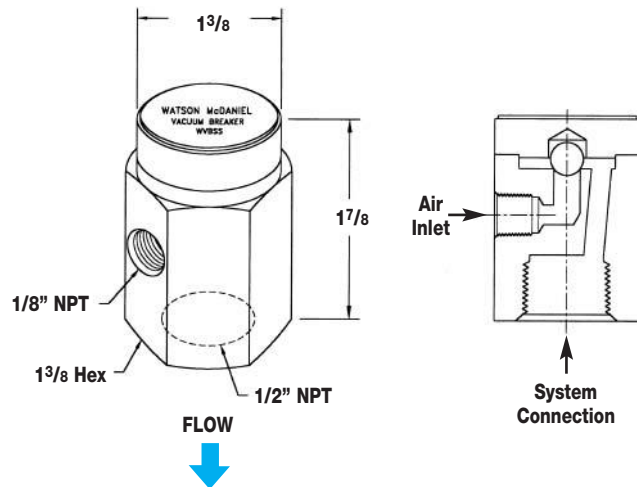

CAPACITIES – Air (SCFM)

Size NPT	inches Hg Vacuum					
	2	4	6	8	10	12
1/2"	2.4	3.4	4.0	4.3	4.7	4.9

SPECIALTY PRODUCTS

WSSCV Series

Stainless Steel Check Valves

Model	WSSCV
Sizes	1/2", 3/4", 1", 1 1/4", 1 1/2", 2", 3"
Connections	NPT, SW
Body Material	316 Stainless Steel
PMO Max. Operating Pressure	500 PSIG
PMA Max. Allowable Pressure	750°F PSIG @ 100°F
TMA Max. Allowable Temperature	850°F @ 420 PSIG

Note: WSSCV is supplied with standard spring for 1/4 PSIG cracking pressure; optional 5 PSIG cracking pressure spring is available upon request.

TYPICAL APPLICATIONS

The Model **WSSCV** is an all stainless steel in-line check valve for steam, gas, or liquid service. It provides tight shut-off, minimizes water hammer and also stops recycling of pumps by preventing back flow of liquid. Used in the petrochemical, pulp & paper, textile and food & beverage industries. The WSSCV all stainless steel check valves will operate much longer and are less problematic than bronze or cast iron check valves.

FEATURES & OPTIONS

- **316 Stainless Steel Body and Internals**
- **Low cracking Pressure on spring (1/4 PSI) to minimize resistance and maximize flow.**
- **Available with optional 5 PSI cracking pressure (must specify at time of order)**
- **Available with NPT, SW, or optional Flanged connections**
- **Spring made from Inconel-X-750 to handle extreme temperature as well as corrosive applications**
- **Body is seam welded to eliminate O-rings or gasket seals which can be affected by high temperature steam or hot condensate**
- **Spring assisted closing of check valve to minimize noise and wear**

SAMPLE SPECIFICATION

Check valve shall have a 316 stainless steel body and disc. Spring shall be made from Inconel-X-750. Check valve body to be seam welded together to eliminate need for O-ring or gasket.



MATERIALS

Body	316 Stainless Steel
Disc	316 Stainless Steel
Spring	Inconel-X-750

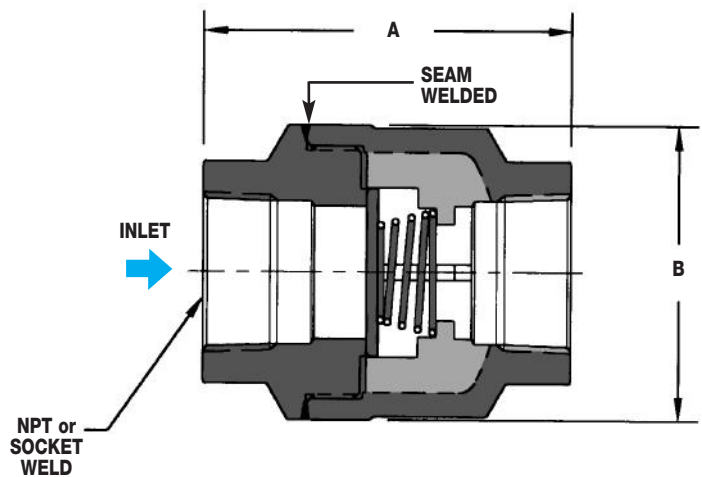

DIMENSIONS & SPECIFICATIONS – inches/pounds

Size	1/2"	3/4"	1"	1 1/4"	1 1/2"	2"	3"
MODEL	WSSCV-12	WSSCV-13	WSSCV-14	WSSCV-15	WSSCV-16	WSSCV-17	WSSCV-19
A	2.69	3.00	3.32	3.81	4.75	5.03	6.87
B	1.62	2.12	2.56	3.06	3.44	4.38	6.19
Weight (lbs)	1.1	1.5	1.9	3.8	4.7	7.7	18.8
Standard Cracking Pressure*	0.25	0.25	0.25	0.25	0.25	0.25	0.25
Optional Cracking Pressure*	5.0	5.0	5.0	5.0	5.0	5.0	5.0
Cv	7	13	22	39	54	93	180

* **Note:** Pressure at which valve opens and flow occurs (PSI).

SPECIALTY PRODUCTS

WFPV

Freeze Protection Valve

Watson McDaniel reserves the right to change the designs and/or materials of its products without notice.
©2010 Watson McDaniel Company

Model	WFPV
Sizes	1/2"
Connections	NPT
Body Material	Stainless Steel
PMO Max. Operating Pressure	200 PSIG
TMO Max. Operating Temperature	300°F



TYPICAL APPLICATIONS

The **WFPV** is used for freeze protection on pipes, valves, fittings, pumps, condensate systems, safety showers, fire lines, spray nozzles, freeze sensitive equipment or as backup protection on steam tracing lines.

HOW IT WORKS

A thermostatic element senses water temperature in the valve. If the temperature falls below 40°F, the valve will modulate open allowing water to drain from the system. The valve will remain open as long as the water flowing by the sensing element is less than 40°F. When the water temperature rises above 40°F, the valve will close.

FEATURES

- Corrosion resistant stainless steel body
- Long service life
- Narrow temperature band
- System pressures will not affect opening temperature

SAMPLE SPECIFICATION

The freeze protection valve shall have a stainless steel body and actuated by a thermostatic element that senses water temperature. The unit shall feature a ram-type plug for reliable and tight shut-off.

INSTALLATION

Unit should be installed in a vertical orientation with flow direction downward. For full details, see Installation and Maintenance Manual.

MATERIALS

Body	Stainless Steel, 303
O-Ring	EPDM
Plug	Brass, CDA-360
Spring	Stainless Steel, 302
Thermal Actuator	Brass, CDA-360

DIMENSIONS & WEIGHTS – inches / pounds

Size NPT	A	B	Weight (lbs)
1/2"	1 1/4	4 1/2	0.9

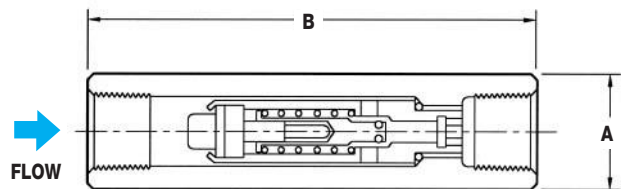

CAPACITIES – Water (lbs/hr)

Inlet Pressure (PSIG)	Capacity (lbs/hr)
50	2475
75	3031
100	3500
125	3913
150	4287
175	4630
200	4950

SPECIALTY PRODUCTS

WSPV

Scald Protection Valve

Model	WSPV
Sizes	1/2", 3/4"
Connections	NPT
Body Material	Stainless Steel
PMO Max. Operating Pressure	200 PSIG
TMO Max. Operating Temperature	300°F



TYPICAL APPLICATIONS

The **WSPV** is used to protect personnel from accidental scalding by over-heated water or other liquids. Installations such as eye-wash stations and safety showers can become over-heated by piping exposed to solar radiation or a heat exchanger malfunction

HOW IT WORKS

When water temperature rises above 95°F, the thermal actuator modulates the valve open. If the water exceeds 115°F, the valve will go to full open position in order to discharge the over-heated water. When the water temperature returns to 95°F, the thermal actuator modulates the valve to close.

FEATURES

- Corrosion resistant stainless steel body
- Long service life
- Narrow temperature band
- System pressures will not affect opening temperature

SAMPLE SPECIFICATION

The scald protection valve shall have a stainless steel body and actuated by a thermal element that senses water temperature. The unit shall feature a ram-type plug for reliable and tight shut-off.

INSTALLATION

Unit should be installed in a vertical orientation with flow direction downward. For full details, see Installation and Maintenance Manual.

MATERIALS

Body	Stainless Steel, 303
Seat Seal	PTFE
Plug	Brass*, CDA-360
Spring	Stainless Steel, 302
Thermal Actuator	Brass*, CDA-360

* All stainless steel version available. Consult Factory.

DIMENSIONS & WEIGHTS – inches / pounds

Size NPT	A	B	Weight (lbs)
1/2"	1 1/4	4 1/2	0.9
3/4"	1 1/2	5 1/2	1.4

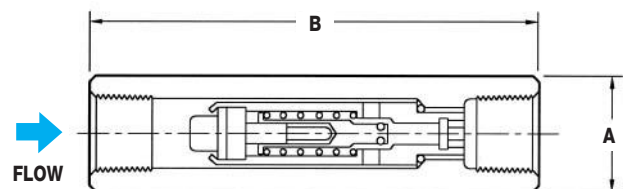

CAPACITIES – Water (lbs/hr)

Inlet Pressure (PSIG)	Capacity (lbs/hr)	
	1/2"	3/4"
50	5,300	7,070
75	6,495	8,660
100	7,500	10,000
125	8,385	11,180
150	9,180	12,240
200	10,600	14,140

SPECIALTY PRODUCTS

SPECIALTY PRODUCTS

WDPL Series

Drip Pan Elbow

Watson McDaniel reserves the right to change the designs and/or materials of its products without notice.
©2010 Watson McDaniel Company

Model	WDPL
Sizes	3/4" through 8"
Connections	NPT, Flanged
Body Material	Cast Iron
PMO Max. Operating Pressure	250 PSIG



WDPL Flanged

TYPICAL APPLICATIONS

The **WDPL** Drip Pan Elbow is used to collect and remove condensate. Typically used with steam boilers, pressure relief valves, safety valves and steam pressure vessels and lines.

FEATURES

- Collects discharge condensate from steam systems
- Returns condensate to safe areas
- Increases life of safety valves
- Reduces discharge piping strain
- Female NPT or Flanged connections available

SAMPLE SPECIFICATION

Drip Pan Elbow shall be made of cast iron and conform to the Power Piping Code. It shall have a pan to collect condensate in the steam riser pipe and a drain to pipe away the condensate.

HOW TO ORDER

Specify pipe size needed for application.

MATERIALS

Body	Cast Iron
------	-----------

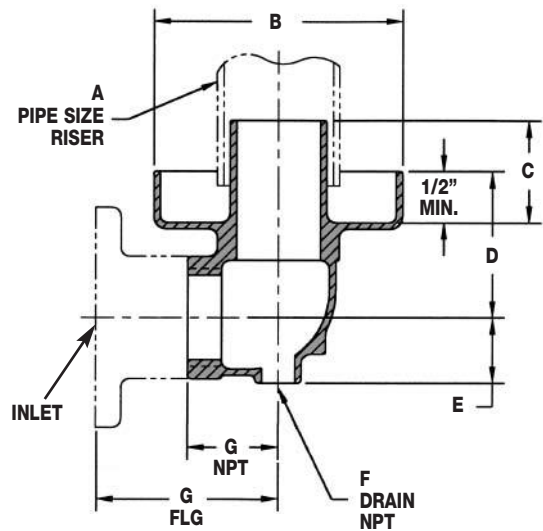

DIMENSIONS & WEIGHTS – inches / pounds

Size	Connection	A	B	C	D	E	F	G	Weight (lbs)
3/4"	NPT	1 1/2	3 3/4	1 3/4	2 3/4	1 1/32	1/4	1 1/2	2
1"	NPT	1 1/2	3 3/4	1 3/4	2 3/4	1 1/32	1/4	1 1/2	2
1 1/4"	NPT	2	5 1/2	2 15/32	4 1/8	1 7/16	3/8	2 1/8	5
1 1/2"	NPT	2	5 1/2	2 15/32	4 1/8	1 7/16	3/8	2 1/8	5
2"	NPT	3	6 1/4	2 3/8	3 5/8	1 5/8	1/2	2 1/4	6.5
2 1/2"	NPT	4	7 3/8	3	4 5/16	1 15/16	3/4	2 11/16	11
3"	NPT	4	8	3 1/2	4 7/8	2 5/16	3/4	3 1/8	14
4"	NPT	6	9 5/8	4 1/2	5 3/4	2 7/8	3/4	3 3/4	27
6"	125# FLG	8	12 3/4	6 5/8	7 9/16	4 3/16	3/4	8	75
8"	125# FLG	10	16 1/2	7 1/2	8 9/16	5 3/8	1	10 3/4	102

SPECIALTY PRODUCTS

SPECIALTY PRODUCTS

WFLV Series

Flash Recovery Vessel

Model	WFLV
Sizes	6", 8", 12", 16"
Connections	150# RF
Body Material	Carbon Steel
PMO Max. Operating Pressure	150 PSIG
TMO Max. Operating Temperature	366°F
PMA Max. Allowable Pressure	150 PSIG @ 562°F

Note: 250 PSIG unit available. Consult factory.

TYPICAL APPLICATION

The WFLV flash recovery vessels are installed in condensate return systems in order to capture and utilize the flash steam coming off of the hot condensate. This flash steam is typically piped away for use on low pressure steam processes.

HOW TO SIZE/ORDER

Use **Table 1** to determine amount of Flash Steam that will be generated by the hot pressurized condensate. The percentage of Flash Steam formed is found where Condensate Pressure and Flash Tank Pressure intersect.

Multiply your Condensate Load by the decimal equivalent of the Flash Steam Percent to determine the amount of Flash Steam in lbs/hr. Then, use **Figure 1** to determine Flash Tank Size required:

Example: Condensate Pressure: **100 PSIG**
 Flash Tank Pressure: **20 PSIG**
 Condensate Load: **8,000 lbs/hr**
 % Flash Steam: **8.7%** from chart
 Decimal Equivalent % Flash Steam = **.087**

.087 x 8000 = 696 lbs/hr of flash steam

Therefore Choose: **12" FLASH TANK**

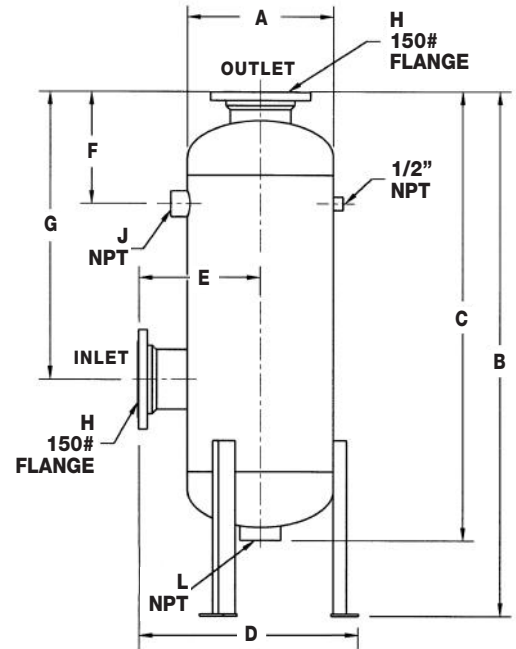
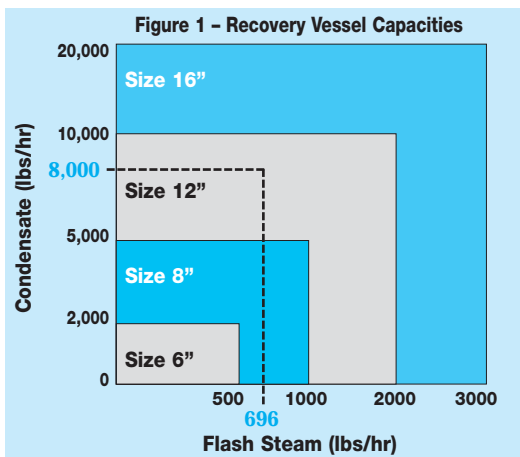

Note: All Watson McDaniel flash recovery vessels are supplied with ASME Section VIII Code Stamp.

Table 1 – PERCENT (%) FLASH STEAM

Produced when condensate is discharged to atmosphere (0 PSIG) or into a flash tank controlled at various pressures

Condensate Pressure (PSIG)	Flash Tank Pressure (PSIG)								
	0	5	10	20	30	40	60	80	100
5	1.6	0.0							
10	2.9	1.3	0.0						
15	3.9	2.4	1.1						
20	4.9	3.3	2.1	0.0					
30	6.5	5.0	3.7	1.7	0.0				
40	7.8	6.3	5.1	3.0	1.4	0.0			
60	10.0	8.5	7.3	5.3	3.7	2.3	0.0		
80	11.8	10.3	9.1	7.1	5.5	4.2	1.9	0.0	
100	13.3	11.8	10.6	8.7	7.1	5.8	3.5	1.6	0.0
125	14.9	13.5	12.3	10.4	8.8	7.5	5.3	3.4	1.8
150	16.3	14.9	13.7	11.8	10.3	9.0	6.8	4.9	3.3
200	18.7	17.3	16.2	14.3	12.8	11.5	9.4	7.6	6.0
250	20.8	19.4	18.2	16.4	14.9	13.7	11.5	9.8	8.2
300	22.5	21.2	20.0	18.2	16.8	15.5	13.4	11.7	10.2
350	24.1	22.8	21.7	19.9	18.4	17.2	15.1	13.4	11.9
400	25.6	24.2	23.1	21.4	19.9	18.7	16.7	15.0	13.5

DIMENSIONS & WEIGHTS – inches/pounds

Size	A	B	C	D	E	F	G	H	J	L	Weight (lbs)
6"	6 ⁵ / ₈	47	38 ¹ / ₂	12	8	9	25 ¹ / ₂	2 ¹ / ₂	3/4	1 ¹ / ₂	75
8"	8 ⁵ / ₈	48	39 ³ / ₄	13	8 ¹ / ₂	9 ¹ / ₂	25 ⁵ / ₈	4	3/4	2	150
12"	12 ³ / ₄	49 ¹ / ₂	41 ¹ / ₄	21	11 ³ / ₄	11 ¹ / ₂	26	5	1 ¹ / ₂	3	165
16"	16	58	50	24	13 ³ / ₈	12 ¹ / ₂	32	6	2	3	215

SPECIALTY PRODUCTS

WSTTV Series

Steam Trap Test Valves

Watson McDaniel reserves the right to change the designs and/or materials of its products without notice.
©2010 Watson McDaniel Company

Model	WSTTV	
Sizes	1/2", 3/4", 1"	
Connections	NPT (Consult Factory for Options)	
Body Material	Bronze or Stainless Steel	
Pressure Ratings	Bronze	150 PSIG WSP
	Stainless Steel	150 PSIG WSP

WSP = Working Steam Pressure

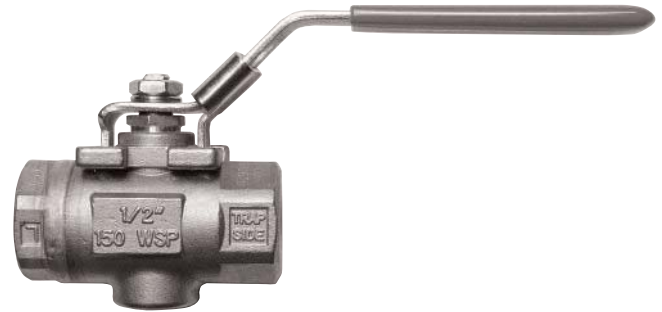

TYPICAL APPLICATIONS

The **WSTTV** Steam Trap Test Valve offers simple, immediate, and visible diagnosis of any steam trap. Turning a single handle will instantly provide steam trap operational data.

HOW IT WORKS

With the **WSTTV** Steam Trap Test Valve installed downstream of the trap and in the open position, steam trap discharges normally. A quarter-turn of the handle repositions the specially designed ball and diverts the trap discharge through a port on the bottom of the valve. Discharge can then be observed and assessments made regarding the operation of the steam trap.

FEATURES (Bronze)

- Full Port
- Cast heavy wall bronze bodies
- Standard locking stainless steel handles

FEATURES (Stainless Steel)

- Seal welded construction
- Full stainless steel construction
- Fully compliant with ASME B16.34 & API 608
- NACE MR-01-75 compliant
- Standard locking stainless steel handles
- Single reduced bore/full porting (depending on size)

INSTALLATION

Test Valve to be mounted on the outlet side of any steam trap. Care should be taken to ensure that the discharge port will be positioned in such a manner so as to avoid danger to personnel. NOT AN ISOLATION OR STOP VALVE.

MAINTENANCE

No maintenance required.

MATERIALS (Bronze)

Description	150 lb. Rating
Body	Bronze B584 C84400
Tailpiece	Brass B124 C27700
Ball	ASTM A276 Gr. 316 SST
Stem	ASTM A276 Gr. 316 SST
Packing Nut	Brass B16 C36000
Seats (2)	R-TFM (Hostafion)
Packing	25% Carbon-filled PTFE
Thrust Washer	R-TFM (Hostafion)
Handle Assembly	300 Series SST
Handle Nut	300 Series SST

MATERIALS (Stainless Steel)

Description	150 lb. Rating
Body	CF8M
Tailpiece	CF8M
Ball	ASTM A276 Gr. 316 SST
Stem	ASTM A276 Gr. 316 SST
Packing Nut	ASTM A276 Gr. 316 SST
Seats (2)	R-TFM (Hostafion)
Tailpiece Seal	Graphite
Thrust Washer	R-TFM (Hostafion)
Stem Packing	Graphite
Lock Washer	300 Series SST
Handle Nut	300 Series SST
Handle Assembly	300 Series SST
Nameplate	300 Series SST

HOW TO ORDER

Specify size, pressure class and options, if applicable. Additional options available; consult factory.

Engineering Data

TABLE OF CONTENTS

Page No.

Formulas, Conversions & Guidelines

- Capacity Formulas for Steam Loads 262
- Steam Trap Sizing & Selection Guidelines 262
- Engineering Guidelines 263
- Recommended Velocities & Pressure Drops for Various Services 263
- Equivalents & Conversion Factors 264
- Cv Formulas for Valve Sizing 265
- Absolute & Kinematic Viscosity Units & Conversions 265

Steam Properties & Flow Characteristics

- Properties of Saturated Steam 266
- Draining Condensate from Steam Mains or Steam Supply Lines 267
- Steam Capacity Tables 268
- Steam Flow thru Various Orifice Diameters 268
- Pressure Drop in Schedule 40 Pipe 269
- Sizing Steam Pipes 269-270
- Percent Flash Steam 271
- Sizing of Condensate Return Line, Vent Line & Flash Tank 271-272

Fluid Flow in Piping

- Flow of Water thru Schedule 40 Steel Pipe – Flow Rates, Velocities & Pressure Drops 273

Pipe, Fitting & Flange Specifications

- Pipe Data Table (for 1/8" thru 30" sizes) 274-276
- Maximum Allowable Working Pressures for Seamless Carbon Steel Pipe 277
- Flange Standards – Dimensional Data 278-279
- Fitting Standards & Specifications 280
- Standard Class Pressure-Temperature Ratings 281-283

Steam Trap Applications

- Introduction to Steam Traps 284
- Thermostatic & Bi-Metallic Steam Traps 285
- Mechanical Steam Traps 286-287
- Thermodynamic Steam Traps 288
- Steam Trap Selection & Sizing 289
- Drip Leg Design 290-291
- Process Steam Trap – Gravity Drainage of Heat Transfer Equipment 292-293
- Process Steam Trap – Siphon Drainage of Heat Transfer Equipment 294-295

Regulating Valve Applications

- General Regulator Application & Installation Notes 296-297
- Single Stage Pressure Reducing Station using Spring-Loaded Pilot 298-299
- Single Stage Pressure Reducing Station using Air-Loaded Pilot for Remote Installations 300-301
- Two-Stage (Series) Pressure Reducing Station 302-303
- Parallel Pressure Reducing Station 304-305
- Two-Stage Parallel Pressure Reducing Station 306-307
- Temperature Control of a Heat Exchanger with Pressure Limiting 308-309
- Automatic Temperature Control of a Batch Process with Electrical Time Sequence Programmer (Solenoid Pilot) 310-311
- Temperature Control of a Semi-Instantaneous Heater using a Self-Contained Temperature Regulating Valve 312-313

Pressure Motive Pump (PMP) Applications

- Drainage of a Single Source of Condensate for a Closed Loop System 314-315
- Drainage of Condensate from Below Grade for a Closed Loop System 316-317
- Flash Steam Recovery 318-319
- Removal of Water or Condensate from a Pit 320-321

FORMULAS, CONVERSIONS & GUIDELINES

CAPACITY FORMULAS FOR STEAM LOADS

When BTU Load is Known	Capacity of steam required (lbs/hr)	= $\frac{\text{BTU}}{1000}$
When Square Feet Equivalent Direct Radiation (EDR) is Known	Capacity of steam required (lbs/hr)	= $\frac{\text{Sq ft. of EDR}}{4}$
When Heating Water with Steam	Capacity of steam required (lbs/hr)	= $\frac{\text{GPM} \times \text{Temp Rise } ^\circ\text{F}}{2}$
When Heating Fuel Oil with Steam	Capacity of steam required (lbs/hr)	= $\frac{\text{GPM} \times \text{Temp Rise } ^\circ\text{F}}{4}$
When Heating Air with Steam Coils	Capacity of steam required (lbs/hr)	= $\frac{\text{CFM} \times \text{Temp Rise } ^\circ\text{F}}{900}$
Boiler Output	Capacity of steam required (lbs/hr)	= $\text{Boiler H.P.} \times 34.5$

HEATING AIR WITH STEAM PIPE COILS

$$\text{Steam (lbs/hr)} = \frac{A \times U \times \Delta T}{L}$$

A = Area of heating surface in sq. ft.

U = Heat transfer coefficient
(U = 2 for free convection)

ΔT = Steam Temperature – Air Temperature in ($^\circ\text{F}$)

L = Latent heat of Steam (BTU/lb) *

* Latent heat of Steam is 970 BTU/lb at 0 PSIG/212 $^\circ\text{F}$.

STEAM TRAP SIZING & SELECTION GUIDELINES

Drip Trap on Steam Mains:

- Should be sized for 2X safety factor at full differential pressure
- Primary choice for trap (up to 30 PSI): Float & Thermostatic
- Primary choice for trap (30-600 PSI): 1/2" WD600L Thermodynamic
3/4 WD600L Thermodynamic
- Place trap every 200 ft. depending on pressure and piping configuration.

Steam Tracing:

- Typically a trap is placed approximately every 100 ft.
- Primary choice for trap: 1/2" WT2000 Thermostatic
1/2" WT1000 Thermostatic
- Thermodynamic and Bucket traps are used on critical tracing applications where no condensate can back up into the steam tracing lines

Process Applications:

For steam systems with constant pressure:

- 2X safety factor based on differential pressure

For steam systems with modulating pressure:

- When used to drain a heat exchanger being supplied by a modulating control valve using up to 30 PSIG steam pressure, trap must handle full load at 1/2 PSI differential pressure.
- When used to drain a heat exchanger being supplied by a modulating control valve using steam pressure greater than 30 PSIG use 2.5X safety factor at full differential pressure.

Primary choice for trap: Float & Thermostatic

ENGINEERING GUIDELINES

1. STEAM MAINS

- A. Trap type & size:
 1. Low Pressures – 0-30 PSI = 3/4" WFT Float & Thermostatic Trap
 2. High Pressures – 30-600 PSI = 1/2" WD-600L Thermodynamic Trap
- B. Distance between traps:
 1. 500 ft. for supervised start up (where drain valves will be manually opened to drain condensate)
 2. 200 ft. for automatic start up (where traps are solely relied upon for drainage of condensate)
- C. Location of Trap:
 1. At all low points
 2. At each change in elevation
 3. Before all control valves
 4. Always put a trap at end of main
- D. Size of Drip Leg for Drain Trap:
 1. Drip Leg Diameter to be equal to steam main diameter for steam main sizes up to 4"
 2. Drip Leg Diameter may be half the steam main diameter for steam main sizes over 4", but not less than 4"
 3. For systems with automatic start-up, Drip Leg Length to be 28" minimum (= 1 PSI minimum head pressure)
 4. For systems with supervised start-up, Drip Leg Length to be 1.5 x Drip Leg Diameter, but not less than 8"

2. **LIFTING CONDENSATE:** Every 2.3 ft. of lift = 1 PSI

3. **1000 BTU = 1 lb. Steam or Condensate**

4. **1 GPM = 500 lbs/hr liquid condensate**

5. **Effect of back pressure on steam trap capacity in % reduction in capacity:**

% Back Pressure	Inlet Pressure (PSI)			
	5	25	100	200
25	6	3	0	0
50	20	12	10	5
75	38	30	28	23

RECOMMENDED VELOCITIES & PRESSURE DROPS FOR VARIOUS SERVICES

SERVICE	VELOCITIES	PRESSURE DROPS (per 100 ft.)
Saturated Steam		
Vacuum	2,000 – 4,000 ft/min	0.25 – 0.5 PSI
0 – 15 PSIG	2,000 – 5,000 ft/min	0.25 – 0.5 PSI
15 – 100 PSIG	2,000 – 7,500 ft/min	0.5 – 1.5 PSI
Over 100 PSIG	2,000 – 9,000 ft/min	0.5 – 2.0 PSI
Steam Main, Low Noise (Hospital, Hotel, etc)	4,000 – 6,000 ft/min	
Steam Main, Industrial Plant	8,000 – 12,000 ft/min	
Superheated Steam		
0-100 PSIG	2,500 – 10,000 ft/min	0.5 – 1.5 PSI
100-500 PSIG	2,500 – 12,000 ft/min	1.0 – 2.0 PSI
Condensate		
Boiler feed pump suction	1.5 – 2.5 ft/sec	
Condensate pump suction	1.5 – 3.0 ft/sec	
Condensate pump discharge	3.0 – 7.5 ft/sec	
Boiler feed pump discharge	4.0 – 10 ft/sec	
Hot Water		
Heating Systems	4.0 ft/sec max for quiet flow	
Pump suction lines	1.0 – 8.0 ft/sec	
Pump discharge lines	5.0 – 15.0 ft/sec	
Cooling Water Systems	5.0 – 15.0 ft/sec	

FORMULAS, CONVERSIONS & GUIDELINES

EQUIVALENTS & CONVERSION FACTORS

A	B	C
MULTIPLY	BY	TO OBTAIN
Atmospheres	14.697	Pounds per sq. in.
Atmospheres	1.033	Kilograms per sq. cm
Atmospheres	29.92	Inches of mercury
Atmospheres	760	Millimeters of mercury
Atmospheres	407	Inches of water
Atmospheres	33.90	Feet of water
Barrels (petroleum)	42	Gallons
Barrels per day	0.0292	Gallons per minute
Bars-G	14.5	Pounds per sq. in.
Centimeters	0.3937	Inches
Centimeters	0.03281	Feet
Centimeters	0.01	Meters
Centimeters	0.01094	Yards
Cubic centimeters	0.06102	Cubic inches
Cubic feet	7.48055	Gallons
Cubic feet	0.17812	Barrels
Cubic feet per second	448.833	Gallons per minute
Cubic inches	16.39	Cubic centimeters
Cubic inches	0.004329	Gallons
Cubic meters	264.17	Gallons
Cubic meters per hour	4.40	Gallons per minute
Feet	0.3048	Meters
Feet	0.3333	Yards
Feet	30.48	Centimeters
Feet of water	0.882	Inches of mercury
Feet of water	0.433	Pounds per sq. in.
Gallons (U.S.)	3785	Cubic centimeters
Gallons (U.S.)	0.13368	Cubic feet
Gallons (U.S.)	231	Cubic inches
Gallons (Imperial)	277.4	Cubic inches
Gallons (U.S.)	0.833	Gallons (Imperial)
Gallons (U.S.)	3.785	Liters
Gallons of water	8.328	Pounds (at 70°F)
Gallons of liquid per minute	500 x Sp. Gr.	Pounds per hr liquid (at 70°F)
Gallons per minute	0.002228	Cubic feet per second
Horsepower (boiler)	34.5	Pounds water per hr. evaporation
Horsepower (boiler)	33479	Btu per hour
Inches	2.54	Centimeters
Inches	0.0833	Feet
Inches	0.0254	Meters
Inches	0.02778	Yards

A	B	C
MULTIPLY	BY	TO OBTAIN
Inches of mercury	1.133	Feet of water
Inches of mercury	0.4912	Pounds per sq. in.
Inches of mercury	0.0345	Kilograms per sq. cm
Inches of water	0.03613	Pounds per sq. in.
Inches of water	0.07355	Inches of mercury
Kilograms	2.205	Pounds
Kilograms	0.001102	Short tons (2000 lbs.)
Kilograms per minute	132.3	Pounds per hour
Kilograms per sq. cm	14.22	Pounds per sq. in.
Kilograms per sq. cm	0.9678	Atmospheres
Kilograms per sq. cm	28.96	Inches of mercury
Kilopascals	0.145	Pounds per sq. in.
Liters	1000	Cubic centimeters
Liters	0.2642	Gallons
Liters per hour	0.0044	Gallons per minute
Meters	3.281	Feet
Meters	1.0936	Yards
Meters	100	Centimeters
Meters	39.37	Inches
Megapascals	145.0	Pounds per sq. in.
Pounds	0.0005	Short tons (2000 lbs.)
Pounds	0.4536	Kilograms
Pounds	0.000454	Metric Tons
Pounds	16	Ounces
Pounds per hour	6.32/M.W.	Cubic feet per minute
Pounds per hour liquid	0.002/Sp. Gr.	Gallons per minute liquid (at 70°F)
Pounds per sq. in.	27.684	Inches of water
Pounds per sq. in.	2.307	Feet of water
Pounds per sq. in.	2.036	Inches of mercury
Pounds per sq. in.	0.0703	Kilograms per sq. cm
Pounds per sq. in.	51.71	Millimeters of mercury
Pounds per sq. in.	0.7037	Meters of water
Specific Gravity (of gas or vapors)	28.97	Molecular Wt. (of gas or vapors)
Square centimeters	0.1550	Square inches
Square inches	6.452	Square centimeters
Tons (short ton 2000 lbs.)	907.2	Kilograms
Tons (short ton 2000 lbs.)	0.9072	Metric Tons
Tons (metric) per day	91.8	Pounds per hour
Water (cubic feet)	62.3	Pounds (at 70°F)
Yards	0.9144	Meters
Yards	91.44	Centimeters

This table may be used in two ways:

- (1) Multiply the unit under column A by the figure under column B; the result is the unit under column C.
- (2) Divide the unit under column C by the figure under column B; the result is the unit under column A.

Cv FORMULAS FOR VALVE SIZING

Cv = WATER CAPACITY in GPM with Pressure Drop of 1 PSI

The formulas for sizing regulating or control valves are based on Fluid Controls Institute Standard FCI 62-1.

The **Cv** number of a valve is its *flow coefficient* and is used to determine the maximum valve capacity (**W**, **Q₁** or **Q**) for any condition, using the formulas below:

Cv = Valve Coefficient

ΔP = Pressure Drop [$P_1 - P_2$]

P_1 = Inlet Pressure Absolute (PSIA)

P_2 = Outlet Pressure Absolute (PSIA)

W = Saturated Steam Flow (lbs/hr)

Q = Flow in Gallons per Minute

Q₁ = Flow in Cubic Feet per Hour

G = Specific Gravity (Water = 1)

G₁ = Specific Gravity Gas (Air = 1 @ 14.7 PSIA @ 60 °F)

T = Rankine Temperature of Flowing Medium ($^{\circ}R = ^{\circ}F + 460$)

STEAM When $\Delta P < 0.5 P_1$:

$$W = 2.1 \times Cv \times \sqrt{\Delta P (P_1 + P_2)}$$

$$Cv = \frac{W}{2.1 \sqrt{\Delta P (P_1 + P_2)}}$$

When $\Delta P \geq 0.5 P_1$:

$$W = 1.82 \times Cv \times P_1$$

$$Cv = \frac{W}{1.82 \times P_1}$$

Steam Flow (**W**) when Pressure Drop is greater than or equal to Critical Pressure Drop ($\Delta P \geq 0.5 P_1$)

GAS When $\Delta P < 0.5 P_1$:

$$Q_1 = 962 \times Cv \times \sqrt{\frac{\Delta P (P_1 + P_2)}{G_1 \times T}}$$

$$Cv = \frac{Q_1}{962} \sqrt{\frac{G_1 \times T}{\Delta P (P_1 + P_2)}}$$

When $\Delta P \geq 0.5 P_1$:

$$Q_1 = 833 \times Cv \times \frac{P_1}{\sqrt{G_1 \times T}}$$

$$Cv = \frac{Q_1 \sqrt{G_1 \times T}}{833 \times P_1}$$

Gas Flow (**Q₁**) when Pressure Drop is greater than or equal to Critical Pressure Drop ($\Delta P \geq 0.5 P_1$)

WATER ($G = 1$)

$$Q = Cv \sqrt{\frac{\Delta P}{G}} = Cv \sqrt{\Delta P}$$

$$Cv = Q \sqrt{\frac{G}{\Delta P}} = Q \sqrt{\frac{1}{\Delta P}}$$

ABSOLUTE & KINEMATIC VISCOSITY UNITS & CONVERSIONS

Absolute Viscosity Units:

1 poise (P) = 1 dyn-s-cm⁻² [cgs system]

1 centipoise (cP) = 10⁻² P = 10⁻² dyn-s-cm⁻² [cgs system]

1 centipoise (cP) = 1 millipascal-second (mPas) [MKS system]

1 centipoise (cP) = 2.0877 x 10⁻⁵ lb-s-ft⁻² [English system]

Kinematic Viscosity Units:

1 stoke (St) = 1 cm²/s [cgs system]

1 centistoke (cSt) = 10⁻² St = 10⁻² cm²/s [cgs system]

Relation between Absolute & Kinematic Viscosity:

$$\text{Kinematic Viscosity (cSt)} = \frac{\text{Absolute Viscosity (cP)}}{\text{Specific Gravity of Fluid}}$$

Properties of Saturated Steam

Pressure	Temp. (°F)	Heat (BTU/lb)			Volume (ft ³ /lb)		Pressure (PSIG)	Temp. (°F)	Heat (BTU/lb)			Volume (ft ³ /lb)	
		Sensible	Latent	Total	Condensate	Steam			Sensible	Latent	Total	Condensate	Steam
(Hg vac)													
25	133	101	1018	1119	0.01626	143.3	150	366	339	857	1196	0.01818	2.756
20	161	129	1002	1131	0.01640	75.41	155	368	341	855	1196	0.01821	2.678
15	179	147	991	1138	0.01650	51.41	160	371	344	853	1196	0.01824	2.605
10	192	160	983	1143	0.01659	39.22	165	373	346	851	1197	0.01827	2.535
5	203	171	976	1147	0.01666	31.82	170	375	349	849	1197	0.01830	2.469
(PSIG)							175	377	351	847	1198	0.01833	2.407
0	212	180	970	1151	0.01672	26.80	180	380	353	845	1198	0.01835	2.347
1	215	184	968	1152	0.01674	25.21	185	382	355	843	1198	0.01839	2.291
2	219	187	966	1153	0.01676	23.79	190	384	358	841	1199	0.01841	2.237
3	222	190	964	1154	0.01679	22.53	195	386	360	839	1199	0.01844	2.185
4	224	193	962	1155	0.01681	21.40	200	388	362	837	1199	0.01847	2.136
5	227	195	961	1156	0.01683	20.38	205	390	364	836	1200	0.01850	2.089
6	230	198	959	1157	0.01685	19.46	210	392	366	834	1200	0.01852	2.044
7	232	201	957	1158	0.01687	18.62	215	394	368	832	1200	0.01855	2.001
8	235	203	956	1159	0.01689	17.85	220	395	370	830	1200	0.01857	1.960
9	237	206	954	1160	0.01690	17.14	225	397	372	829	1201	0.01860	1.920
10	239	208	953	1160	0.01692	16.49	230	399	374	827	1201	0.01863	1.882
12	244	212	950	1162	0.01696	15.33	235	401	376	825	1201	0.01865	1.845
14	248	216	947	1163	0.01699	14.33	240	403	378	823	1201	0.01868	1.810
16	252	220	944	1165	0.01702	13.45	245	404	380	822	1202	0.01870	1.776
18	255	224	942	1166	0.01705	12.68	250	406	382	820	1202	0.01873	1.744
20	259	228	940	1167	0.01708	11.99	255	408	384	818	1202	0.01875	1.712
22	262	231	937	1168	0.01711	11.38	260	409	385	817	1202	0.01878	1.682
24	265	234	935	1169	0.01713	10.83	265	411	387	815	1202	0.01880	1.652
25	267	236	934	1170	0.01715	10.57	270	413	389	814	1203	0.01882	1.624
26	268	237	933	1170	0.01716	10.33	275	414	391	812	1203	0.01885	1.596
28	271	240	931	1171	0.01719	9.874	280	416	392	811	1203	0.01887	1.570
30	274	243	929	1172	0.01721	9.459	285	417	394	809	1203	0.01889	1.544
32	277	246	927	1173	0.01723	9.078	290	419	396	808	1203	0.01891	1.520
34	279	249	925	1174	0.01726	8.728	295	420	397	806	1203	0.01894	1.497
35	281	250	924	1174	0.01727	8.563	300	422	399	805	1203	0.01896	1.473
36	282	251	923	1174	0.01728	8.404	310	425	402	802	1204	0.01901	1.428
38	284	254	922	1175	0.01730	8.104	320	428	405	799	1204	0.01906	1.386
40	287	256	920	1176	0.01733	7.826	330	430	408	796	1204	0.01910	1.346
42	289	258	918	1177	0.01735	7.566	340	433	411	793	1204	0.01915	1.309
44	291	261	916	1177	0.01737	7.323	350	436	414	790	1204	0.01919	1.273
45	292	262	916	1178	0.01738	7.208	360	438	417	787	1204	0.01923	1.240
46	294	263	915	1178	0.01739	7.096	370	441	420	785	1204	0.01927	1.207
48	296	265	913	1178	0.01741	6.883	380	443	423	782	1205	0.01932	1.177
50	298	267	912	1179	0.01743	6.683	390	446	426	779	1205	0.01936	1.148
55	303	272	908	1180	0.01748	6.230	400	448	428	777	1205	0.01940	1.120
60	307	277	905	1182	0.01753	5.837	450	460	441	764	1205	0.01961	0.9992
65	312	282	901	1183	0.01757	5.491	500	470	453	752	1205	0.01980	0.9010
70	316	286	898	1184	0.01761	5.184	550	480	464	740	1204	0.02000	0.8195
75	320	291	895	1185	0.01766	4.911	600	489	475	729	1203	0.02019	0.7509
80	324	295	892	1186	0.01770	4.665	650	497	485	718	1203	0.02038	0.6922
85	328	298	889	1187	0.01774	4.444	700	505	494	707	1202	0.02056	0.6415
90	331	302	886	1188	0.01778	4.242	750	513	504	697	1200	0.02074	0.5971
95	335	306	883	1189	0.01782	4.059	800	520	512	687	1199	0.02092	0.5580
100	338	309	881	1190	0.01785	3.891	900	534	529	667	1196	0.02128	0.4922
105	341	312	878	1190	0.01789	3.736	1000	546	545	648	1192	0.02164	0.4390
110	344	316	876	1191	0.01792	3.594	1250	574	581	601	1182	0.02256	0.3410
115	347	319	873	1192	0.01796	3.462	1500	598	614	556	1169	0.02352	0.2740
120	350	322	871	1192	0.01799	3.340	1750	618	644	510	1155	0.02456	0.2248
125	353	325	868	1193	0.01803	3.226	2000	637	674	463	1137	0.02572	0.1864
130	356	328	866	1194	0.01806	3.119	2250	654	703	413	1116	0.02707	0.1554
135	358	331	864	1194	0.01809	3.020	2500	669	734	358	1092	0.02871	0.1293
140	361	333	861	1195	0.01812	2.927	2750	683	766	295	1061	0.03097	0.1062
145	363	336	859	1195	0.01815	2.839	3000	696	805	211	1016	0.03465	0.0835
							3194	706	906	0	906	0.05078	0.0508

DRAINING CONDENSATE FROM STEAM MAINS OR STEAM SUPPLY LINES

Charts Assume All Pipes are Insulated (with 80% efficiency)

Warm Up Loads in Pounds of Condensate per hour per 100 ft. of Steam Main

Outside Temperature at 70°F. Based on Sch. 40 Pipe up to 250 PSI; Sch. 80 above 250 PSI; Sch. 120, 5" & Larger, above 800 PSI.															
Steam Pressure (PSIG)	Pipe Size														°F Correction Factor †
	2"	2½"	3"	4"	5"	6"	8"	10"	12"	14"	16"	18"	20"	24"	
0	6.2	9.7	12.8	18.2	24.6	31.9	48	68	90	107	140	176	207	308	1.5
5	6.9	11.0	14.4	20.4	27.7	35.9	48	77	101	120	157	198	233	324	1.44
10	7.5	11.8	15.5	22.0	29.9	38.8	58	83	109	130	169	213	251	350	1.41
20	8.4	13.4	17.5	24.9	33.8	44	66	93	124	146	191	241	284	396	1.37
40	9.9	15.8	20.6	30.3	39.7	52	78	110	145	172	225	284	334	465	1.32
60	11.0	17.5	22.9	32.6	44	57	86	122	162	192	250	316	372	518	1.29
80	12.0	19.0	24.9	35.3	48	62	93	132	175	208	271	342	403	561	1.27
100	12.8	20.3	26.6	37.8	51	67	100	142	188	222	290	366	431	600	1.26
125	13.7	21.7	28.4	40	55	71	107	152	200	238	310	391	461	642	1.25
150	14.5	23.0	30.0	43	58	75	113	160	212	251	328	414	487	679	1.24
175	15.3	24.2	31.7	45	61	79	119	169	224	265	347	437	514	716	1.23
200	16.0	25.3	33.1	47	64	83	125	177	234	277	362	456	537	748	1.22
250	17.2	27.3	35.8	51	69	89	134	191	252	299	390	492	579	807	1.21
300	25.0	38.3	51	75	104	143	217	322	443	531	682	854	1045	1182	1.20
400	27.8	43	57	83	116	159	241	358	493	590	759	971	1163	1650	1.18
500	30.2	46	62	91	126	173	262	389	535	642	825	1033	1263	1793	1.17
600	32.7	50	67	98	136	187	284	421	579	694	893	1118	1367	1939	1.16
800	38	58	77	113	203	274	455	670	943	1132	1445	1835	2227	3227	1.16
1000	45	64	86	126	227	305	508	748	1052	1263	1612	2047	2485	3601	1.15
1200	52	72	96	140	253	340	566	833	1172	1407	1796	2280	2767	4010	1.14
1400	62	79	106	155	280	376	626	922	1297	1558	1988	2524	3064	4440	1.13
1600	71	87	117	171	309	415	692	1018	1432	1720	2194	2786	3382	4901	1.13
1750	78	94	126	184	333	448	746	1098	1544	1855	2367	3006	3648	5285	1.13
1800	80	97	129	189	341	459	764	1125	1584	1902	2427	3082	3741	5420	1.13

Running Loads in Pounds of Condensate per hour per 100 ft. of Steam Main

Outside Temperature at 70°F. Based on Sch. 40 Pipe up to 250 PSI; Sch. 80 above 250 PSI; Sch. 120, 5" & Larger, above 800 PSI.															
Steam Pressure (PSIG)	Pipe Size														°F Correction Factor †
	2"	2½"	3"	4"	5"	6"	8"	10"	12"	14"	16"	18"	20"	24"	
10	6	7	9	11	13	16	20	24	29	32	36	39	44	53	1.58
30	8	9	11	14	17	20	26	32	38	42	48	51	57	68	1.50
60	10	12	14	18	24	27	33	41	49	54	62	67	74	89	1.45
100	12	15	18	22	28	33	41	51	61	67	77	83	93	111	1.41
125	13	16	20	24	30	36	45	56	66	73	84	90	101	121	1.39
175	16	19	23	26	33	43	53	66	78	86	98	107	119	141	1.38
250	18	22	27	34	42	50	62	77	92	101	116	126	140	168	1.36
300	20	25	30	37	46	54	68	85	101	111	126	138	154	184	1.35
400	23	28	34	43	53	63	80	99	118	130	148	162	180	216	1.33
500	27	33	39	49	61	73	91	114	135	148	170	185	206	246	1.32
600	30	37	44	55	68	82	103	128	152	167	191	208	232	277	1.31
800	36	44	53	69	85	101	131	164	194	214	244	274	305	365	1.30
1000	43	52	63	82	101	120	156	195	231	254	290	326	363	435	1.27
1200	51	62	75	97	119	142	185	230	274	301	343	386	430	515	1.26
1400	60	73	89	114	141	168	219	273	324	356	407	457	509	610	1.25
1600	69	85	103	132	163	195	253	31	375	412	470	528	588	704	1.22
1750	76	93	113	145	179	213	278	347	411	452	516	580	645	773	1.22
1800	79	96	117	150	185	221	288	358	425	467	534	600	667	800	1.21

† For outdoor temperatures of 0°F, multiply load value selected from table by correction factor shown.

STEAM PROPERTIES & FLOW CHARACTERISTICS

STEAM CAPACITY TABLES

This chart provides a simple method for sizing steam pipes with velocities in the range of 7,000 to 10,000 ft/min. (Example: a 1" pipe with 100 PSIG steam pressure has a flow rate of 672 lbs/hr at a velocity of 7250 ft/min.)

STEAM CAPACITY — Flow in lbs/hr		FULL-PORT VALVE or PIPE SIZE																
Pressure (PSIG)	Temp. (°F) (sat.)	1/4	3/8	1/2	3/4	1	1 1/4	1 1/2	2	2 1/2	3	3 1/2	4	5	6	8	10	12
		VELOCITY (FPM)																
		7062	7094	7125	7187	7250	7312	7375	7500	7625	7750	7875	8000	8250	8500	9000	9500	10000
250	406	176	324	518	916	1498	2615	3591	6018	8731	13700	18620	24360	39470	58730	107700	179200	267700
200	388	143	264	423	748	1223	2135	2932	4913	7128	11190	15200	19880	32230	47950	87910	146300	218500
175	378	127	235	375	664	1086	1895	2603	4361	6328	9931	13490	17650	28610	42560	78040	129800	194000
150	366	111	205	328	580	948	1655	2273	3810	5528	8675	11790	15420	24990	37180	68170	113400	169500
125	353	95	175	280	496	811	1415	1943	3256	4724	7414	10070	13180	21360	31780	58260	96940	144800
100	338	79	145	232	411	672	1173	1612	2701	3919	6150	8356	10930	17720	26360	48330	80410	120100
90	331	72	133	213	377	617	1076	1478	2477	3594	5641	7665	10030	16250	24180	44330	73760	110200
80	324	66	121	194	343	561	979	1345	2254	3270	5132	6973	9122	14780	22000	40330	67100	100300
70	316	59	109	175	309	505	881	1211	2029	2943	4619	6277	8211	13310	19800	36300	60400	90240
60	308	53	97	155	274	449	783	1076	1803	2616	4105	5577	7296	11820	17590	32260	53670	80190
50	298	46	85	136	240	392	684	940	1575	2286	3587	4874	6376	10330	15380	28190	46900	70080
40	287	39	72	116	205	335	585	803	1346	1953	3066	4166	5449	8831	13140	24090	40080	59890
30	274	33	60	96	170	278	485	666	1115	1618	2539	3451	4514	7315	10880	19960	33200	49610
25	267	29	54	86	152	249	434	596	999	1449	2274	3090	4042	6551	9747	17870	29730	44430
20	259	26	47	76	134	219	383	526	881	1279	2006	2726	3566	5780	8600	15770	26230	39200
15	250	22	41	66	116	190	331	455	763	1107	1737	2360	3087	5003	7444	13650	22710	33930
10	240	19	35	55	98	160	279	384	643	933	1464	1990	2603	4218	6276	11510	19150	28610
5	228	15	28	45	79	130	227	311	522	757	1188	1615	2112	3423	5093	9339	15540	23220
0	212	11	21	34	60	97	170	233	391	568	891	1210	1583	2566	3818	7000	11650	17400

This table represents steam loss thru an orifice on a failed open steam trap, assuming that 25% of the flow consists of condensate.

STEAM FLOW — thru various orifice diameters discharging to atmosphere (0 PSIG) in lbs/hr		Inlet Pressure (PSIG)											
Orifice Diameter (Inches)	2	5	10	15	25	50	75	100	125	150	200	250	300
1/32	0.31	0.47	0.58	0.70	0.94	1.53	2.12	2.70	3.30	3.90	5.10	6.30	7.40
1/16	1.25	1.86	2.30	2.80	3.80	6.10	8.50	10.80	13.20	15.60	20.30	25.10	29.80
3/32	2.81	4.20	5.30	6.30	8.45	13.80	19.10	24.40	29.70	35.10	45.70	56.40	67.00
1/8	4.50	7.50	7.40	11.20	15.00	24.50	34.00	43.40	52.90	62.40	81.30	100.00	119.00
5/32	7.80	11.70	14.60	17.60	23.50	38.30	53.10	67.90	82.70	97.40	127.00	156.00	186.00
3/16	11.20	16.70	21.00	25.30	33.80	55.10	76.40	97.70	119.00	140.00	183.00	226.00	268.00
7/32	15.30	22.90	28.70	34.40	46.00	75.00	104.00	133.00	162.00	191.00	249.00	307.00	365.00
1/4	20.00	29.80	37.40	45.00	60.10	98.00	136.00	173.00	212.00	250.00	325.00	401.00	477.00
9/32	25.20	37.80	47.40	56.90	76.10	124.00	172.00	220.00	268.00	316.00	412.00	507.00	603.00
5/16	31.20	46.60	58.50	70.30	94.00	153.00	212.00	272.00	331.00	390.00	508.00	627.00	745.00
11/32	37.70	56.40	70.70	85.10	114.00	185.00	257.00	329.00	400.00	472.00	615.00	758.00	901.00
3/8	44.90	67.10	84.20	101.00	135.00	221.00	306.00	391.00	478.00	561.00	732.00	902.00	1073.00
13/32	52.70	78.80	98.80	119.00	159.00	259.00	359.00	459.00	559.00	659.00	859.00	1059.00	1259.00
7/16	61.10	91.40	115.00	138.00	184.00	300.00	416.00	532.00	648.00	764.00	996.00	1228.00	1460.00
15/32	70.20	105.00	131.00	158.00	211.00	344.00	478.00	611.00	744.00	877.00	1144.00	1410.00	1676.00
1/2	79.80	119.00	150.00	180.00	241.00	392.00	544.00	695.00	847.00	998.00	1301.00	1604.00	1907.00

PRESSURE DROP IN SCHEDULE 40 PIPE

100 PSIG Saturated Steam

For other pressures use correction factors

psi	0	0	5	10	15	20	30	40	60	75	90	100	110	125	150	175	200	225	250	300	350	400	500	600
factor	6.9	6.0	5.2	4.3	3.6	3.1	2.4	2.0	1.5	1.3	1.1	1.0	0.92	0.83	0.70	0.62	0.55	0.49	0.45	0.38	0.33	0.29	0.23	0.19

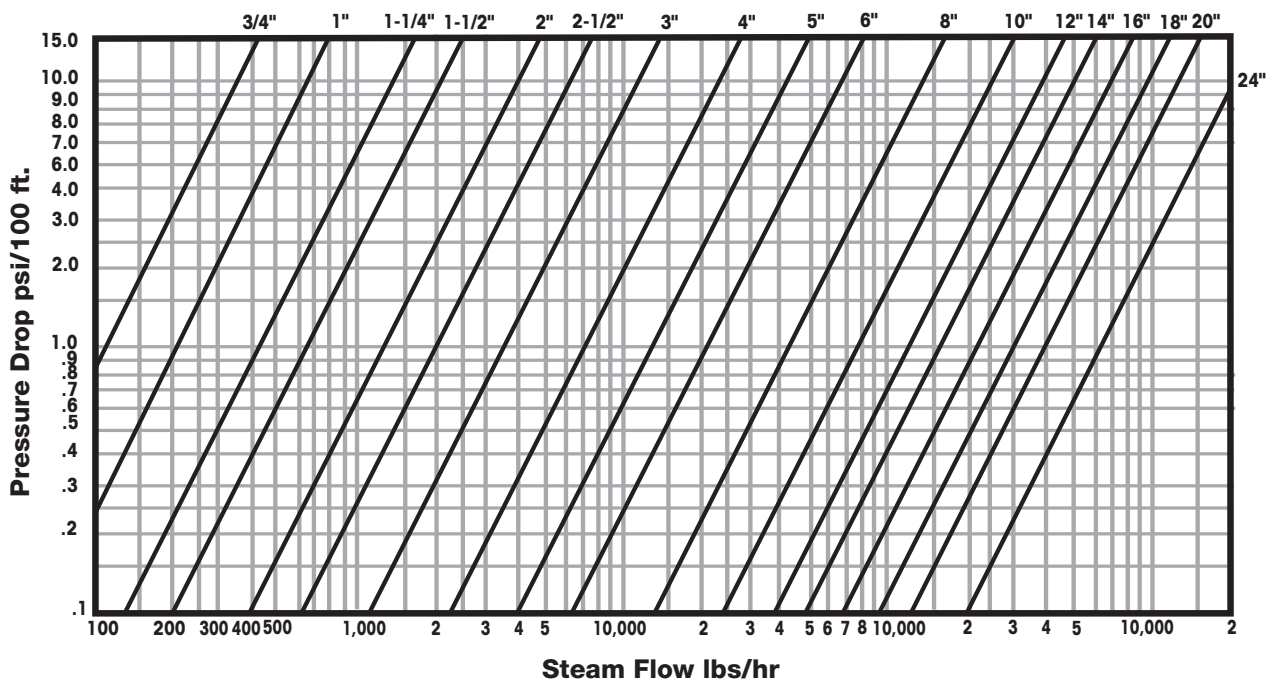

SIZING STEAM PIPES

Saturated steam lines should be sized for a steam velocity of 4800 to 7200 ft/min.

Piping on pressure reducing stations should be sized for the same steam velocity on both sides of the regulator. This usually results in having a regulator smaller than the piping and having larger piping on the downstream side of the regulator.

Example using Steam Velocity Chart (see next page):

- 100 PSIG Inlet Pressure to control valve;
- 25 PSIG Outlet Pressure;
- 1000 lbs/hr flow rate;
- Determine pipe size required.

Upstream Piping:

- Enter Velocity Chart at **A** 1000 lbs/hr.
- Follow line to **B** 100 PSIG Inlet Pressure.
- Follow line vertically upwards to **C** 1 1/2" Pipe Diameter.
- Steam Velocity at **D** shows 4800 ft/min.

Downstream Piping:

- Enter Velocity Chart at **A** 1000 lbs/hr.
- Follow line to **E** 25 PSIG Outlet Pressure.
- Follow line vertically upwards to **F** 2 1/2" Pipe Diameter.
- Steam Velocity at **G** shows 5500 ft/min.

STEAM VELOCITY CHART (Schedule 40 Pipe)

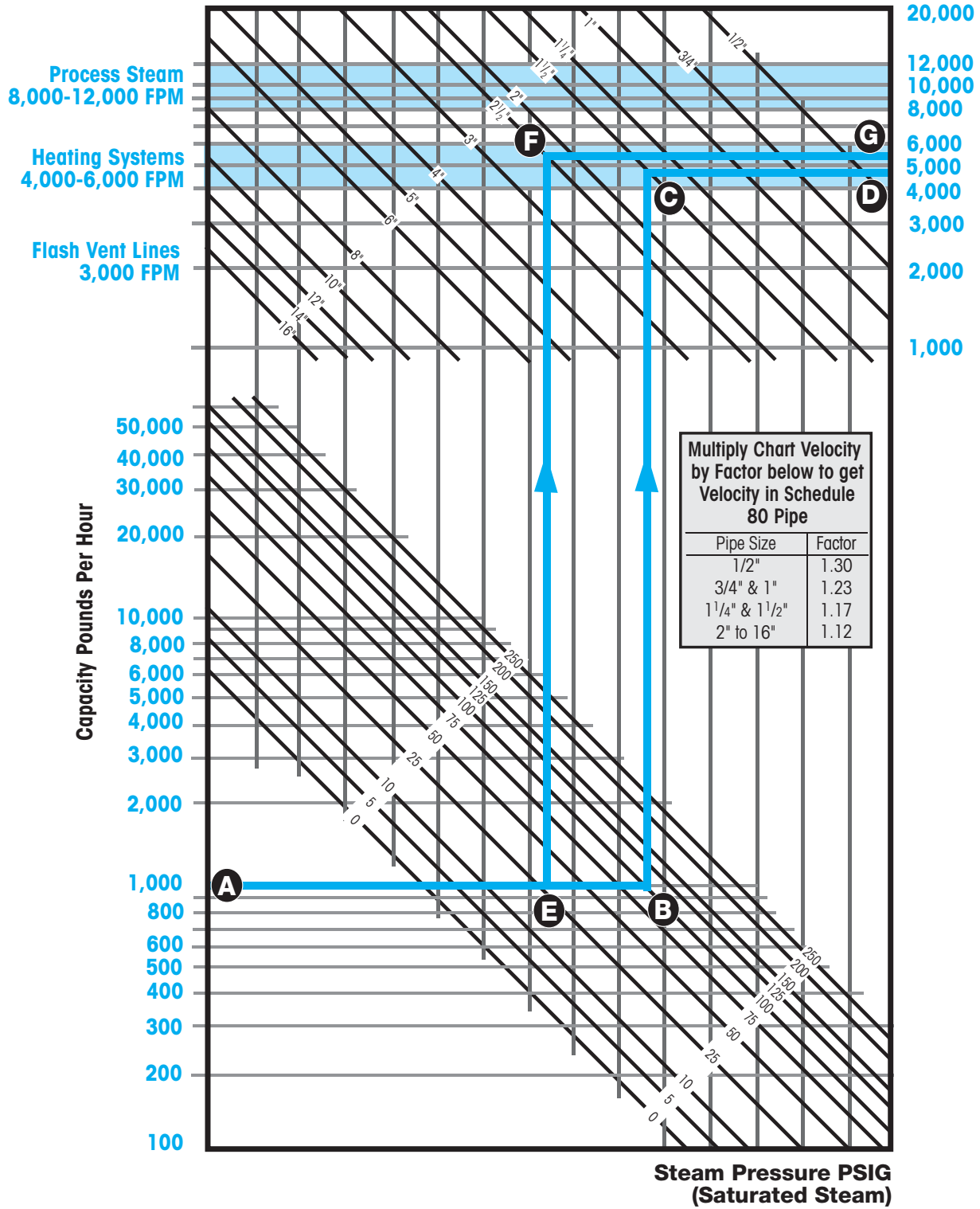

PERCENT (%) FLASH STEAM									
Percent Flash Steam produced when condensate is discharged to atmosphere (0 PSIG) or into a flash tank controlled at various pressures									
Condensate Pressure (PSIG)	Flash Tank Pressure (PSIG)								
	0	5	10	20	30	40	60	80	100
5	1.6	0.0							
10	2.9	1.3	0.0						
15	3.9	2.4	1.1						
20	4.9	3.3	2.1	0.0					
30	6.5	5.0	3.7	1.7	0.0				
40	7.8	6.3	5.1	3.0	1.4	0.0			
60	10.0	8.5	7.3	5.3	3.7	2.3	0.0		
80	11.8	10.3	9.1	7.1	5.5	4.2	1.9	0.0	
100	13.3	11.8	10.6	8.7	7.1	5.8	3.5	1.6	0.0
125	14.9	13.5	12.3	10.4	8.8	7.5	5.3	3.4	1.8
150	16.3	14.9	13.7	11.8	10.3	9.0	6.8	4.9	3.3
200	18.7	17.3	16.2	14.3	12.8	11.5	9.4	7.6	6.0
250	20.8	19.4	18.2	16.4	14.9	13.7	11.5	9.8	8.2
300	22.5	21.2	20.0	18.2	16.8	15.5	13.4	11.7	10.2
350	24.1	22.8	21.7	19.9	18.4	17.2	15.1	13.4	11.9
400	25.6	24.2	23.1	21.4	19.9	18.7	16.7	15.0	13.5

SIZING OF CONDENSATE RETURN LINE, VENT LINE & FLASH TANK

Velocity of Flash Steam in Condensate Return Lines should be between 4000 and 6000 ft/min. Velocity in Flash Tank should be less than 600 ft/min. Velocity in a Vent Pipe should be less than 4000 ft/min.

Example: A steam trap with a 160 PSIG steam inlet pressure is being discharged into a flash tank operating at 20 PSIG. The condensate load on the trap is 3000 lbs/hr.

Problem:

- 1) Determine the size of the condensate return line from the trap to the flash tank
- 2) Determine the size of the flash tank
- 3) Determine the size of the vent line on the flash tank

Solution:

The accepted practice of determining condensate return pipe sizing is to base the size of the return pipe on the amount of flash steam in the return line. This is due to the fact that the volume of flash steam is over 1000 times greater than the equivalent volume of liquid condensate. Therefore, the flash steam is the dominant factor affecting flow in the return line. We must first calculate the amount of flash steam produced.

From the **Percent Flash Steam Chart** we find that 12.4% of the condensate will flash into steam. Therefore $.124 \times 3000 = 372$ lbs/hr of flash steam will be produced in the condensate return line and flash tank.

Enter **Condensate Line, Flash Tank & Vent Line Sizing** chart at **A** 372 lbs/hr.

Move horizontally to point **B** 20 PSIG Flash Tank Pressure.

Move vertically upwards to point **D** to determine a 5" Flash Tank Diameter is needed to keep velocities less than 600 ft/min.

Continue to move vertically to point **E** to determine that the Vent Line on the Flash Tank should be 2" Diameter in order to keep velocities less than 4000 ft/min.

Continue to move vertically to point **C** to determine that the Condensate Line Diameter should be 1 1/2" Diameter to maintain condensate return line velocities between 4000 and 6000 ft/min.

STEAM PROPERTIES & FLOW CHARACTERISTICS

CONDENSATE LINE, FLASH TANK & VENT LINE SIZING (Schedule 40 Pipe)

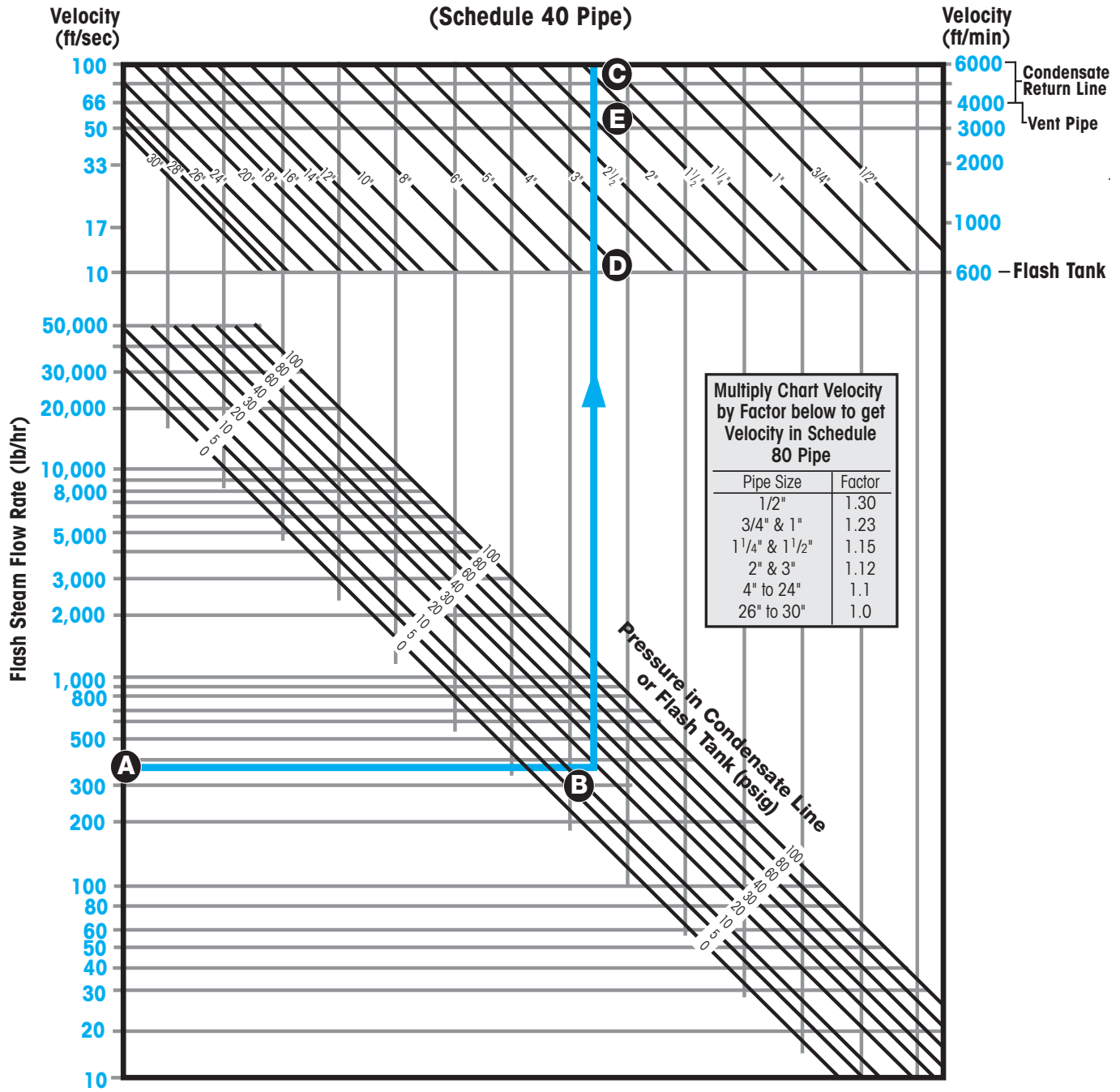

Flow of Water thru Schedule 40 Steel Pipe

Pressure Drop per 1,000 Feet of Schedule 40 Steel Pipe

Flow Rate (GPM)	Velocity (ft/s)	Pressure Drop (PSI)	Velocity (ft/s)	Pressure Drop (PSI)	Velocity (ft/s)	Pressure Drop (PSI)	Velocity (ft/s)	Pressure Drop (PSI)	Velocity (ft/s)	Pressure Drop (PSI)	Velocity (ft/s)	Pressure Drop (PSI)	Velocity (ft/s)	Pressure Drop (PSI)	Velocity (ft/s)	Pressure Drop (PSI)	Velocity (ft/s)	Pressure Drop (PSI)
1"																		
1	0.37	0.49																
2	0.74	1.70	1 1/4"															
3	1.12	3.53	0.64	0.94	1 1/2"													
4	1.49	5.94	0.86	1.55	0.63	0.74												
5	1.86	9.02	1.07	2.36	0.79	1.12	2"											
6	2.24	12.25	1.28	3.30	0.95	1.53	0.57	0.46										
8	2.98	21.1	1.72	5.52	1.26	2.63	0.76	0.75	2 1/2"									
10	3.72	30.8	2.14	8.34	1.57	3.86	0.96	1.14	0.67	0.48								
15	5.60	64.6	3.21	17.6	2.36	8.13	1.43	2.33	1.00	0.99	3"							
20	7.44	110.5	4.29	29.1	3.15	13.5	1.91	3.86	1.34	1.64	0.87	0.59	3 1/2"					
25			5.36	43.7	3.94	20.2	2.39	5.81	1.68	2.48	1.08	0.67	0.81	0.42				
30			6.43	62.9	4.72	29.1	2.87	8.04	2.01	3.43	1.30	1.21	0.97	0.60	4"			
35			7.51	82.5	5.51	38.2	3.35	10.95	2.35	4.49	1.52	1.58	1.14	0.79	0.88	0.42		
40					6.30	47.8	3.82	13.7	2.68	5.88	1.74	2.06	1.30	1.00	1.01	0.53		
45					7.08	60.6	4.30	17.4	3.00	7.14	1.95	2.51	1.46	1.21	1.13	0.67		
50					7.87	74.7	4.78	20.6	3.35	8.82	2.17	3.10	1.62	1.44	1.26	0.80		
60							5.74	29.6	4.02	12.2	2.60	4.29	1.95	2.07	1.51	1.10	5"	
70							6.69	38.6	4.69	15.3	3.04	5.84	2.27	2.71	1.76	1.50	1.12	0.48
80							7.65	50.3	5.37	21.7	3.48	7.62	2.59	3.53	2.01	1.87	1.28	0.63
90							8.60	63.6	6.04	26.1	3.91	9.22	2.92	4.46	2.26	2.37	1.44	0.80
100	1.11	0.39					9.56	75.1	6.71	32.3	4.34	11.4	3.24	5.27	2.52	2.81	1.60	0.95
125	1.39	0.56							8.38	48.2	5.42	17.1	4.05	7.86	3.15	4.38	2.00	1.48
150	1.67	0.78							10.06	60.4	6.51	23.5	4.86	11.3	3.78	6.02	2.41	2.04
175	1.94	1.06							11.73	90.0	7.59	32.0	5.67	14.7	4.41	8.20	2.81	2.78
200	2.22	1.32	8"								8.68	39.7	6.48	19.2	5.04	10.2	3.21	3.46
225	2.50	1.66	1.44	0.44							9.77	50.2	7.29	23.1	5.67	12.9	3.61	4.37
250	2.78	2.05	1.60	0.55							10.85	61.9	8.10	28.5	6.30	15.9	4.01	5.14
275	3.06	2.36	1.76	0.63							11.94	75.0	8.91	34.4	6.93	18.3	4.41	6.22
300	3.33	2.80	1.92	0.75							13.02	84.7	9.72	40.9	7.56	21.8	4.81	7.41
325	3.61	3.29	2.08	0.88									10.53	45.5	8.18	25.5	5.21	8.25
350	3.89	3.62	2.24	0.97									11.35	52.7	8.82	29.7	5.61	9.57
375	4.16	4.16	2.40	1.11									12.17	60.7	9.45	32.3	6.01	11.0
400	4.44	4.72	2.56	1.27									12.97	68.9	10.08	36.7	6.41	12.5
425	4.72	5.34	2.72	1.43									13.78	77.8	10.70	41.5	6.82	14.1
450	5.00	5.96	2.88	1.60	10"								14.59	87.3	11.33	46.5	7.22	15.0
475	5.27	6.66	3.04	1.69	1.93	0.30									11.96	51.7	7.62	16.7
500	5.55	7.39	3.20	1.87	2.04	0.63									12.59	57.3	8.02	18.5
550	6.11	8.94	3.53	2.26	2.24	0.70									13.84	69.3	8.82	22.4
600	6.66	10.6	3.85	2.70	2.44	0.86									15.10	82.5	9.62	26.7
650	7.21	11.8	4.17	3.16	2.65	1.01	12"										10.42	31.3
700	7.77	13.7	4.49	3.69	2.85	1.18	2.01	0.48									11.22	36.3
750	8.32	15.7	4.81	4.21	3.05	1.35	2.15	0.55									12.02	41.6
800	8.88	17.8	5.13	4.79	3.26	1.54	2.29	0.62	14"								12.82	44.7
850	9.44	20.2	5.45	5.11	3.46	1.74	2.44	0.70	2.02	0.43							13.62	50.5
900	10.00	22.6	5.77	5.73	3.66	1.94	2.58	0.79	2.14	0.48							14.42	56.6
950	10.55	23.7	6.09	6.38	3.87	2.23	2.72	0.88	2.25	0.53							15.22	63.1
1,000	11.10	26.3	6.41	7.08	4.07	2.40	2.87	0.98	2.38	0.59							16.02	70.0
1,100	12.22	31.8	7.05	8.56	4.48	2.74	3.16	1.18	2.61	0.68	16"						17.63	84.6
1,200	13.32	37.8	7.69	10.2	4.88	3.27	3.45	1.40	2.85	0.81	2.18	0.40						
1,300	14.43	44.4	8.33	11.3	5.29	3.86	3.73	1.56	3.09	0.95	2.36	0.47						
1,400	15.54	51.5	8.97	13.0	5.70	4.44	4.02	1.80	3.32	1.10	2.54	0.54						
1,500	16.65	55.5	9.62	15.0	6.10	5.11	4.30	2.07	3.55	1.19	2.73	0.62						
1,600	17.76	63.1	10.26	17.0	6.51	5.46	4.59	2.36	3.80	1.35	2.91	0.71	18"					
1,800	19.98	79.8	11.54	21.6	7.32	6.91	5.16	2.98	4.27	1.71	3.27	0.85	2.58	0.48				
2,000	22.20	98.5	12.83	25.0	8.13	8.54	5.73	3.47	4.74	2.11	3.63	1.05	2.88	0.56				
2,500			16.03	39.0	10.18	12.5	7.17	5.41	5.92	3.09	4.54	1.63	3.59	0.88	20"			
3,000			19.24	52.4	12.21	18.0	8.60	7.31	7.12	4.45	5.45	2.21	4.31	1.27	3.45	0.73		
3,500			22.43	71.4	14.25	22.9	10.03	9.95	8.32	6.18	6.35	3.00	5.03	1.52	4.03	0.94	24"	
4,000			25.65	93.3	16.28	29.9	11.48	13.0	9.49	7.92	7.25	3.92	5.74	2.12	4.61	1.22	3.19	0.51
4,500					18.31	37.8	12.90	15.4	10.67	9.36	8.17	4.97	6.47	2.50	5.19	1.55	3.59	0.60
5,000					20.35	46.7	14.34	18.9	11.84	11.6	9.08	5.72	7.17	3.08	5.76	1.78	3.99	0.74
6,000					24.42	67.2	17.21	27.3	14.32	15.4	10.88	8.24	8.62	4.45	6.92	2.57	4.80	1.00
7,000					28.50	85.1	20.08	37.2	16.60	21.0	12.69	12.2	10.04	6.06	8.06	3.50	5.68	1.36
8,000							22.95	45.1	18.98	27.4	14.52	13.6	11.48	7.34	9.23	4.57	6.38	1.78
9,000							25.80	57.0	21.35	34.7	16.32	17.2	12.92	9.20	10.37	5.36	7.19	2.25
10,000							28.63	70.4	23.75	42.9	18.16	21.2	14.37	11.5	11.53	6.63	7.96	2.78
12,000							34.38	93.6	28.50	61.8	21.80	30.9	17.23	16.5	13.83	9.54	9.57	3.71
14,000									33.20	84.0	25.42	41.6	20.10	20.7	16.14	12.0	11.18	5.05
16,000											29.05	54.4	22.96	27.1	18.43	15.7	12.77	6.60

PIPE, FITTING & FLANGE SPECIFICATIONS

PIPE DATA TABLE

Pipe Size (in.)	Outside Diameter (in.)	Weight Class	Carbon Steel Schedule	Stainless Steel Schedule	Wall Thickness (in.)	Inside Diameter (in.)	Circum. (Ext.) (in.)	Circum. (Int.) (in.)	Flow Area (sq. in.)	Weight of Pipe (lbs/Ft.)	Weight of Water (lbs/Ft.)	Gallons of Water per Ft.	Section Modulus	Pipe Size (in.)
1/8	0.405	-	-	10S	.049	.307	1.27	.96	.074	.19	.032	.004	.00437	1/8
		STD	40	40S	.068	.269		.85	.057	.24	.025	.003	.00523	
		XS	80	80S	.095	.215		.68	.036	.31	.016	.002	.00602	
1/4	0.540	-	-	10S	.065	.410	1.70	1.29	.132	.33	.057	.007	.01032	1/4
		STD	40	40S	.088	.364		1.14	.104	.42	.045	.005	.01227	
		XS	80	80S	.119	.302		.95	.072	.54	.031	.004	.01395	
3/8	0.675	-	-	10S	.065	.545	2.12	1.71	.233	.42	.101	.012	.01736	3/8
		STD	40	40S	.091	.493		1.55	.191	.57	.083	.010	.0216	
		XS	80	80S	.126	.423		1.33	.141	.74	.061	.007	.0255	
1/2	0.840	-	-	5S	.065	.710	2.64	2.23	.396	.54	.172	.021	.0285	1/2
		-	-	10S	.083	.674		2.12	.357	.67	.155	.019	.0341	
		STD	40	40S	.109	.622		1.95	.304	.85	.132	.016	.0407	
		XS	80	80S	.147	.546		1.72	.234	1.09	.102	.012	.0478	
		-	160	-	.187	.466		1.46	.171	1.31	.074	.009	.0527	
		XXS	-	-	.294	.252		.79	.050	1.71	.022	.003	.0577	
3/4	1.050	-	-	5S	.065	.920	3.30	2.89	.665	.69	.288	.035	.0467	3/4
		-	-	10S	.083	.884		2.78	.614	.86	.266	.032	.0566	
		STD	40	40S	.113	.824		2.59	.533	1.13	.231	.028	.0706	
		XS	80	80S	.154	.742		2.33	.433	1.47	.188	.022	.0853	
		-	160	-	.219	.612		1.92	.296	1.94	.128	.015	.1004	
		XXS	-	-	.308	.434		1.36	.148	2.44	.064	.008	.1103	
1	1.315	-	-	5S	.065	1.185	4.13	3.72	1.103	.87	.478	.057	.0760	1
		-	-	10S	.109	1.097		3.45	.945	1.40	.409	.049	.1151	
		STD	40	40S	.133	1.049		3.30	.864	1.68	.375	.045	.1328	
		XS	80	80S	.179	.957		3.01	.719	2.17	.312	.037	.1606	
		-	160	-	.250	.815		2.56	.522	2.84	.230	.027	.1903	
		XXS	-	-	.358	.599		1.88	.282	3.66	.122	.015	.2136	
1 1/4	1.660	-	-	5S	.065	1.530	5.22	4.81	1.839	1.11	.797	.096	.1250	1 1/4
		-	-	10S	.109	1.442		4.53	1.633	1.81	.708	.085	.1934	
		STD	40	40S	.140	1.380		4.34	1.495	2.27	.649	.078	.2346	
		XS	80	80S	.191	1.278		4.02	1.283	3.00	.555	.067	.2913	
		-	160	-	.250	1.160		3.64	1.057	3.76	.458	.055	.3421	
		XXS	-	-	.382	.896		2.81	.630	5.21	.273	.033	.4110	
1 1/2	1.900	-	-	5S	.065	1.770	5.97	5.56	2.461	1.28	1.066	.128	.1662	1 1/2
		-	-	10S	.109	1.682		5.28	2.222	2.09	.963	.115	.2598	
		STD	40	40S	.145	1.610		5.06	2.036	2.72	.882	.106	.3262	
		XS	80	80S	.200	1.500		4.71	1.767	3.63	.765	.092	.4118	
		-	160	-	.281	1.338		4.20	1.406	4.86	.608	.073	.5078	
		XXS	-	-	.400	1.100		3.46	.950	6.41	.420	.049	.5977	
2	2.375	-	-	5S	.065	2.245	7.46	7.05	3.958	1.61	1.72	.206	.2652	2
		-	-	10S	.109	2.157		6.78	3.654	2.64	1.58	.190	.4204	
		STD	40	40S	.154	2.067		6.49	3.355	3.65	1.45	.174	.5606	
		XS	80	80S	.218	1.939		6.09	2.953	5.02	1.28	.153	.7309	
		-	160	-	.344	1.687		5.30	2.241	7.46	.97	.116	.9790	
		XXS	-	-	.436	1.503		4.72	1.774	9.03	.77	.092	1.1040	
2 1/2	2.875	-	-	5S	.083	2.709	9.03	8.51	5.764	2.48	2.50	.299	.4939	2 1/2
		-	-	10S	.120	2.635		8.28	5.453	3.53	2.36	.283	.6868	
		STD	40	40S	.203	2.469		7.76	4.788	5.79	2.07	.249	1.064	
		XS	80	80S	.276	2.323		7.30	4.238	7.66	1.87	.220	1.339	
		-	160	-	.375	2.125		6.68	3.546	10.01	1.54	.184	1.638	
		XXS	-	-	.552	1.771		5.56	2.464	13.69	1.07	.128	1.997	
3	3.500	-	-	5S	.083	3.334	11.00	10.47	8.730	3.03	3.78	.454	.744	3
		-	-	10S	.120	3.260		10.24	8.347	4.33	3.62	.434	1.041	
		STD	40	40S	.216	3.068		9.64	7.393	7.58	3.20	.384	1.724	
		XS	80	80S	.300	2.900		9.11	6.605	10.25	2.86	.343	2.225	
		-	160	-	.438	2.624		8.24	5.408	14.32	2.35	.281	2.876	
		XXS	-	-	.600	2.300		7.23	4.155	18.58	1.80	.216	3.424	
4	4.500	-	-	5S	.083	4.334	14.14	13.62	14.75	3.92	6.39	.766	1.249	4
		-	-	10S	.120	4.260		13.38	14.25	5.61	6.18	.740	1.761	
		STD	40	40S	.237	4.026		12.65	12.73	10.79	5.50	.661	3.214	
		XS	80	80S	.337	3.826		12.02	11.50	14.98	4.98	.597	4.271	
		-	120	-	.438	3.624		11.39	10.31	19.00	4.47	.536	5.178	
		XXS	-	-	.531	3.438		10.80	9.28	22.51	4.02	.482	5.898	
5	5.563	-	-	5S	.109	5.345	17.48	16.79	22.44	6.36	9.72	1.17	2.498	5
		-	-	10S	.134	5.295		16.63	22.02	7.77	9.54	1.14	3.029	
		STD	40	40S	.258	5.047		15.86	20.01	14.62	8.67	1.04	5.451	
		XS	80	80S	.375	4.813		15.12	18.19	20.78	7.88	.945	7.431	
		-	120	-	.500	4.563		14.34	16.35	27.04	7.09	.849	9.250	
		XXS	-	-	.625	4.313		13.55	14.61	32.96	6.33	.759	10.796	
					.750	4.063		12.76	12.97	38.55	5.61	.674	12.090	

PIPE, FITTING & FLANGE SPECIFICATIONS

PIPE DATA TABLE (continued)

Pipe Size (in.)	Outside Diameter (in.)	Weight Class	Carbon Steel Schedule	Stainless Steel Schedule	Wall Thickness (in.)	Inside Diameter (in.)	Circum. (Ext.) (in.)	Circum. (Ext.) (in.)	Flow Area (sq. in.)	Weight of Pipe (lbs/Ft.)	Weight of Water (lbs/Ft.)	Gallons of Water per Ft.	Section Modulus	Pipe Size (in.)
6	6.625	-	-	5S	.109	6.407	20.81	20.13	32.24	7.60	13.97	1.68	3.576	6
		-	-	10S	.134	6.357		19.97	31.74	9.29	13.75	1.65	4.346	
		STD	40	40S	.280	6.065		19.05	28.89	18.97	12.51	1.50	8.496	
		XS	80	80S	.432	5.761		18.10	26.07	28.57	11.29	1.35	12.22	
		-	120	-	.562	5.501		17.28	23.77	36.39	10.30	1.24	14.98	
		-	160	-	.719	5.187		16.30	21.15	45.35	9.16	1.10	17.81	
		XXS	-	-	.864	4.897		15.38	18.84	53.16	8.16	.978	20.02	
8	8.625	-	-	5S	.109	8.407	27.10	26.41	55.51	9.93	24.06	2.88	6.131	8
		-	-	10S	.148	8.329		26.17	54.48	13.40	23.61	2.83	8.212	
		-	20	-	.250	8.125		25.53	51.85	22.36	22.47	2.69	13.39	
		-	30	-	.277	8.071		25.36	51.16	24.70	22.17	2.66	14.69	
		STD	40	40S	.322	7.981		25.07	50.03	28.55	21.70	2.60	16.81	
		-	60	-	.406	7.813		24.55	47.94	35.64	20.77	2.49	20.58	
		XS	80	80S	.500	7.625		23.95	45.66	43.39	19.78	2.37	24.51	
		-	100	-	.594	7.437		23.36	43.46	50.95	18.83	2.26	28.14	
		-	120	-	.719	7.187		22.58	40.59	60.71	17.59	2.11	32.58	
		-	140	-	.812	7.001		21.99	38.50	67.76	16.68	2.00	35.65	
		XXS	-	-	.875	6.875		21.60	37.12	72.42	16.10	1.93	37.56	
-	160	-	.906	6.813	21.40	36.46	74.69	15.80	1.89	38.48				
10	10.750	-	-	5S	.134	10.482	33.77	32.93	86.29	15.19	37.39	4.48	11.71	10
		-	-	10S	.165	10.420		32.74	85.28	18.65	36.95	4.43	14.30	
		-	20	-	.250	10.250		32.20	82.52	28.04	35.76	4.29	21.15	
		-	30	-	.307	10.136		31.84	80.69	34.24	34.96	4.19	25.57	
		STD	40	40S	.365	10.020		31.48	78.86	40.48	34.20	4.10	29.90	
		XS	60	80S	.500	9.750		30.63	74.66	54.74	32.35	3.88	39.43	
		-	80	-	.594	9.562		30.04	71.84	64.43	31.13	3.73	45.54	
		-	100	-	.719	9.312		29.25	68.13	77.03	29.53	3.54	53.22	
		-	120	-	.844	9.062		28.47	64.53	89.29	27.96	3.35	60.32	
		XXS	140	-	1.000	8.750		27.49	60.13	104.13	26.06	3.12	68.43	
		-	160	-	1.125	8.500		26.70	56.75	115.64	24.59	2.95	74.29	
12	12.750	-	-	5S	.156	12.438	40.06	39.08	121.50	20.98	52.65	6.31	19.2	12
		-	-	10S	.180	12.390		38.92	120.57	24.17	52.25	6.26	22.0	
		-	20	-	.250	12.250		38.48	117.86	33.38	51.07	6.12	30.2	
		-	30	-	.330	12.090		37.98	114.80	43.77	49.74	5.96	39.0	
		STD	40	40S	.375	12.000		37.70	113.10	49.56	49.00	5.88	43.8	
		-	60	-	.406	11.938		37.50	111.93	53.52	48.50	5.81	47.1	
		XS	80	80S	.500	11.750		36.91	108.43	65.42	46.92	5.63	56.7	
		-	100	-	.562	11.626		36.52	106.16	73.15	46.00	5.51	62.8	
		-	120	-	.688	11.374		35.73	101.64	88.63	44.04	5.28	74.6	
		XXS	140	-	.844	11.062		34.75	96.14	107.32	41.66	4.99	88.1	
		-	160	-	1.000	10.750		33.77	90.76	125.49	39.33	4.71	100.7	
-	140	-	1.125	10.500	32.99	86.59	139.67	37.52	4.50	109.9				
-	160	-	1.312	10.126	31.81	80.53	160.27	34.89	4.18	122.6				
14	14.000	-	-	5S	.156	13.688	43.98	43.00	147.15	23.07	63.77	7.64	23.2	14
		-	-	10S	.188	13.624		42.80	145.78	27.73	63.17	7.57	27.8	
		-	10	-	.250	13.500		42.41	143.14	36.71	62.03	7.44	36.6	
		-	20	-	.312	13.376		42.02	140.52	45.61	60.89	7.30	45.0	
		STD	30	-	.375	13.250		41.63	137.88	54.57	59.75	7.16	53.2	
		-	40	-	.438	13.124		41.23	135.28	63.44	58.64	7.03	61.3	
		XS	60	-	.500	13.000		40.84	132.73	72.09	57.46	6.90	69.1	
		-	80	-	.594	12.812		40.25	128.96	85.05	55.86	6.70	80.3	
		-	100	-	.750	12.500		39.27	122.72	106.13	53.18	6.37	98.2	
		-	120	-	.938	12.124		38.09	115.49	130.85	50.04	6.00	117.8	
		XXS	140	-	1.094	11.812		37.11	109.62	150.79	47.45	5.69	132.8	
-	160	-	1.250	11.500	36.13	103.87	170.28	45.01	5.40	146.8				
-	140	-	1.406	11.188	35.15	98.31	189.11	42.60	5.11	159.6				
16	16.000	-	-	5S	.165	15.670	50.27	49.23	192.85	27.90	83.57	10.02	32.2	16
		-	-	10S	.188	15.624		49.08	191.72	31.75	83.08	9.96	36.5	
		-	10	-	.250	15.500		48.69	188.69	42.05	81.74	9.80	48.0	
		-	20	-	.312	15.376		48.31	185.69	52.27	80.50	9.65	59.2	
		STD	30	-	.375	15.250		47.91	182.65	62.58	79.12	9.49	70.3	
		XS	40	-	.500	15.000		47.12	176.72	82.77	76.58	9.18	91.5	
		-	60	-	.656	14.688		46.14	169.44	107.50	73.42	8.80	116.6	
		-	80	-	.844	14.312		44.96	160.92	136.61	69.73	8.36	144.5	
		-	100	-	1.031	13.938		43.79	152.58	164.82	66.12	7.93	170.5	
		-	120	-	1.219	13.562		42.61	144.50	192.43	62.62	7.50	194.5	
		XXS	140	-	1.438	13.124		41.23	135.28	233.64	58.64	7.03	220.0	
-	160	-	1.594	12.812	40.26	128.96	245.25	55.83	6.70	236.7				

ENGINEERING

PIPE, FITTING & FLANGE SPECIFICATIONS

PIPE DATA TABLE (continued)

Pipe Size (in.)	Outside Diameter (in.)	Weight Class	Carbon Steel Schedule	Stainless Steel Schedule	Wall Thickness (in.)	Inside Diameter (in.)	Circum. (Ext.) (in.)	Circum. (Ext.) (in.)	Flow Area (sq. in.)	Weight of Pipe (lbs/Ft.)	Weight of Water (lbs/Ft.)	Gallons of Water per Ft.	Section Modulus	Pipe Size (in.)				
18	18.00	-	-	5S	.165	17.67	56.55	55.51	245.22	31.43	106.26	12.74	40.8	18				
		-	-	10S	.188	17.62		55.37	243.95	35.76	105.71	12.67	46.4					
		-	10	-	.250	17.50		54.98	240.53	47.39	104.21	12.49	61.1					
		-	20	-	.312	17.38		54.59	237.13	58.94	102.77	12.32	75.5					
		STD	-	-	.375	17.25		54.19	233.71	70.59	101.18	12.14	89.6					
		-	30	-	.438	17.12		53.80	230.30	82.15	99.84	11.96	103.4					
		XS	-	-	.500	17.00		53.41	226.98	93.45	98.27	11.79	117.0					
		-	40	-	.562	16.88		53.02	223.68	104.87	96.93	11.62	130.1					
		-	60	-	.750	16.50		51.84	213.83	138.17	92.57	11.11	168.3					
		-	80	-	.938	16.12		50.66	204.24	170.92	88.50	10.61	203.8					
		-	100	-	1.156	15.69		49.29	193.30	207.96	83.76	10.04	242.3					
		-	120	-	1.375	15.25		47.91	182.66	244.14	79.07	9.49	277.6					
		-	140	-	1.562	14.88		46.73	173.80	274.22	75.32	9.03	305.5					
-	160	-	1.781	14.44	45.36	163.72	308.50	70.88	8.50	335.6								
20	20.00	-	-	5S	.188	19.62	62.83	61.65	302.46	39.78	131.06	15.71	57.4	20				
		-	-	10S	.218	19.56		61.46	300.61	46.06	130.27	15.62	66.3					
		-	10	-	.250	19.50		61.26	298.65	52.73	129.42	15.51	75.6					
		-	20	-	.375	19.25		60.48	290.04	78.60	125.67	15.12	111.3					
		STD	30	-	.500	19.00		59.69	283.53	104.13	122.87	14.73	145.7					
		XS	40	-	.594	18.81		59.10	278.00	123.11	120.46	14.44	170.4					
		-	60	-	.812	18.38		57.73	265.21	166.40	114.92	13.78	225.7					
		-	80	-	1.031	17.94		56.35	252.72	208.87	109.51	13.13	277.1					
		-	100	-	1.281	17.44		54.78	238.83	256.10	103.39	12.41	331.5					
		-	120	-	1.500	17.00		53.41	226.98	296.37	98.35	11.79	375.5					
		-	140	-	1.750	16.50		51.84	213.82	341.09	92.66	11.11	421.7					
		-	160	-	1.969	16.06		50.46	202.67	379.17	87.74	10.53	458.5					
		22	22.00	-	-	5S		.188	21.62	69.12	67.93	367.25	43.80		159.14	19.08	69.7	22
-	-			10S	.218	21.56	67.75	365.21	50.71		158.26	18.97	80.4					
-	10			-	.250	21.50	67.54	363.05	58.07		157.32	18.86	91.8					
STD	20			-	.375	21.25	66.76	354.66	86.61		153.68	18.42	135.4					
XS	30			-	.500	21.00	65.97	346.36	114.81		150.09	17.99	177.5					
-	60			-	.875	20.25	63.62	322.06	197.41		139.56	16.73	295.0					
-	80			-	1.125	19.75	62.05	306.35	250.81		132.76	15.91	366.4					
-	100			-	1.375	19.25	60.48	291.04	302.88		126.12	15.12	432.6					
-	120			-	1.625	18.75	58.90	276.12	353.61		119.65	14.34	493.8					
-	140			-	1.875	18.25	57.33	261.59	403.00		113.36	13.59	550.3					
-	160			-	2.125	17.75	55.76	247.45	451.06		107.23	12.85	602.4					
24	24.00			-	-	5S	.218	23.56	75.40		74.03	436.10	55	188.98	22.65	96.0	24	
				-	10	10S	.250	23.50			73.83	433.74	63	187.95	22.53	109.6		
		STD	20	-	.375	23.25	73.04	424.56		95	183.95	22.05	161.9					
		XS	-	-	.500	23.00	72.26	415.48		125	179.87	21.58	212.5					
		-	30	-	.562	22.88	71.86	411.00		141	178.09	21.35	237.0					
		-	40	-	.688	22.62	71.08	402.07		171	174.23	20.88	285.1					
		-	60	-	.969	22.06	69.31	382.35		238	165.52	19.86	387.7					
		-	80	-	1.219	21.56	67.74	365.22		297	158.26	18.97	472.8					
		-	100	-	1.531	20.94	65.78	344.32		367	149.06	17.89	570.8					
		-	120	-	1.812	20.38	64.01	326.08		430	141.17	16.94	652.1					
		-	140	-	2.062	19.88	62.44	310.28		483	134.45	16.12	718.9					
		-	160	-	2.344	19.31	60.67	292.98		542	126.84	15.22	787.9					
		30	30.00	-	-	5S	.250	29.50		94.25	92.68	683.49	79	296.18	35.51	172.3		30
-	10			10S	.312	29.38	92.29	677.71	99		293.70	35.21	213.8					
STD	-			-	.375	29.25	91.89	671.96	119		291.18	34.91	255.3					
XS	20			-	.500	29.00	91.11	660.52	158		286.22	34.31	336.1					
-	30			-	.625	28.75	90.32	649.18	196		281.31	33.72	414.9					

PIPE, FITTING & FLANGE SPECIFICATIONS

MAXIMUM ALLOWABLE WORKING PRESSURES FOR SEAMLESS CARBON STEEL PIPE													
Nominal Pipe Size (in.)	Maximum allowable working pressure at -20 to 650 °F ▲												
	SCH 10	SCH 20	SCH 30	STD WALL	SCH 40	SCH 60	XH	SCH 80	SCH 100	SCH 120	SCH 140	SCH 160	XXH
1/2	-	-	-	1694	1694	-	3036	3036	-	-	-	4551	9223
3/4	659	-	-	1450	1450	-	2589	2589	-	-	-	4505	7531
1	1065	-	-	1578	1578	-	2601	2601	-	-	-	4290	7150
1 1/4	556	-	-	1069	1069	-	1941	1941	-	-	-	3001	5593
1 1/2	486	-	-	1004	1004	-	1821	1821	-	-	-	3091	5114
2	388	-	-	903	903	-	1659	1659	-	-	-	3225	4475
2 1/2	431	-	-	1214	1214	-	1936	1936	-	-	-	2963	4936
3	346	-	-	1094	1094	-	1773	1773	-	-	-	2933	4405
3 1/2	303	-	-	1023	1023	-	1671	1671	-	-	-	-	-
4	269	-	-	974	974	-	1598	1598	-	2243	-	2868	3858
5	284	-	-	888	888	-	1475	1475	-	2123	-	2791	3485
6	239	-	-	833	833	-	1473	1473	-	2038	-	2738	3414
8	225	543	628	770	1038	1343	1343	1649	2068	2388	2715	2605	-
10	224	434	578	723	723	1070	1070	1311	1641	1975	2406	2754	-
12	219	366	534	630	696	1033	898	1305	1653	2009	2295	2735	-
14	333	451	573	573	693	999	816	1311	1690	2013	2341	2675	-
16	291	395	500	500	711	980	711	1305	1638	1975	2378	2669	-
18	258	350	538	444	725	1013	631	1303	1648	1998	2303	2665	-
20	233	399	568	399	693	995	568	1299	1653	1970	2338	2663	-
22	211	-	-	363	-	-	515	-	-	-	-	-	-
24	194	331	541	331	683	1004	471	1295	1664	2003	2309	2656	-
26	-	-	-	306	-	-	435	-	-	-	-	-	-
30	209	376	488	265	-	-	376	-	-	-	-	-	-
36	-	-	-	220	-	-	314	-	-	-	-	-	-
42	-	-	-	189	-	-	269	-	-	-	-	-	-

▲ For allowable working pressures at higher temperatures, multiply values listed above by the following factors:

Grade A

Temperature	700 °F	750 °F	800 °F	850 °F	900 °F
Multiply by	0.971	0.892	0.750	0.708	0.417

Grade B

Temperature	700 °F	750 °F	800 °F	850 °F	900 °F
Multiply by	0.956	0.853	0.720	0.620	0.333

PIPE, FITTING & FLANGE SPECIFICATIONS

FLANGE STANDARDS – Dimensional Data in inches

125 lb. CAST IRON

ANSI STANDARD B16.1

PIPE SIZE	1/2	3/4	1	1 1/4	1 1/2	2	2 1/2	3	3 1/2	4	5	6	8	10	12
Diameter of Flange	–	–	4 1/4	4 5/8	5	6	7	7 1/2	8 1/2	9	10	11	13 1/2	16	19
Thickness of Flange (min) ^a	–	–	7/16	1/2	9/16	5/8	11/16	3/4	13/16	15/16	15/16	1	1 1/8	1 3/16	1 1/4
Diameter of Bolt Circle	–	–	3 1/8	3 1/2	3 7/8	4 3/4	5 1/2	6	7	7 1/2	8 1/2	9 1/2	11 3/4	14 1/4	17
Number of Bolts	–	–	4	4	4	4	4	4	8	8	8	8	8	12	12
Diameter of Bolts	–	–	1/2	1/2	1/2	5/8	5/8	5/8	5/8	5/8	3/4	3/4	3/4	7/8	7/8

^a 125 lb. Cast Iron Flanges have plain faces (i.e. not raised faces).

250 lb. CAST IRON

ANSI STANDARD B16.1

PIPE SIZE	1/2	3/4	1	1 1/4	1 1/2	2	2 1/2	3	3 1/2	4	5	6	8	10	12
Diameter of Flange	–	–	4 7/8	5 1/4	6 1/8	6 1/2	7 1/2	8 1/4	9	10	11	12 1/2	15	17 1/2	20 1/2
Thickness of Flange (min) ^b	–	–	1 1/16	3/4	13/16	7/8	1	1 1/8	1 3/16	1 1/4	1 3/8	1 7/16	1 5/8	1 7/8	2
Diameter of Raised Face	–	–	2 11/16	3 1/16	3 9/16	4 3/16	4 15/16	5 11/16	6 5/16	6 15/16	8 5/16	9 11/16	11 15/16	14 1/16	16 7/16
Diameter of Bolt Circle	–	–	3 1/2	3 7/8	4 1/2	5	5 7/8	6 5/8	7 1/4	7 7/8	9 1/4	10 5/8	13	15 1/4	17 3/4
Number of Bolts	–	–	4	4	4	8	8	8	8	8	8	12	12	16	16
Diameter of Bolts	–	–	5/8	5/8	3/4	5/8	3/4	3/4	3/4	3/4	3/4	3/4	7/8	1	1 1/8

^b 250 lb. Cast Iron Flanges have a 1/16" raised face which is included in the flange thickness dimensions.

150 lb. BRONZE

ANSI STANDARD B16.24

PIPE SIZE	1/2	3/4	1	1 1/4	1 1/2	2	2 1/2	3	3 1/2	4	5	6	8	10	12
Diameter of Flange	3 1/2	3 7/8	4 1/4	4 5/8	5	6	7	7 1/2	8 1/2	9	10	11	13 1/2	16	19
Thickness of Flange (min) ^c	5/16	11/32	3/8	13/32	7/16	1/2	9/16	5/8	11/16	1 1/16	3/4	13/16	15/16	1	1 1/16
Diameter of Bolt Circle	2 3/8	2 3/4	3 1/8	3 1/2	3 7/8	4 3/4	5 1/2	6	7	7 1/2	8 1/2	9 1/2	11 3/4	14 1/4	17
Number of Bolts	4	4	4	4	4	4	4	4	8	8	8	8	8	12	12
Diameter of Bolts	1/2	1/2	1/2	1/2	1/2	5/8	5/8	5/8	5/8	5/8	3/4	3/4	3/4	7/8	7/8

^c 150 lb. Bronze Flanges have plain faces (i.e. not raised faces) with two concentric gasket-retaining grooves between the port and the bolt holes.

300 lb. BRONZE

ANSI STANDARD B16.24

PIPE SIZE	1/2	3/4	1	1 1/4	1 1/2	2	2 1/2	3	3 1/2	4	5	6	8	10	12
Diameter of Flange	3 3/4	4 5/8	4 7/8	5 1/4	6 1/2	6 1/2	7 1/2	8 1/4	9	10	11	12 1/2	15	–	–
Thickness of Flange (min) ^d	1/2	17/32	19/32	5/8	1 1/16	3/4	13/16	29/32	31/32	1 1/16	1 1/8	1 3/16	1 3/8	–	–
Diameter of Bolt Circle	2 5/8	3 1/4	3 1/2	3 7/8	4 1/2	5	5 7/8	6 5/8	7 1/4	7 7/8	9 1/4	10 5/8	13	–	–
Number of Bolts	4	4	4	4	4	8	8	8	8	8	8	12	12	–	–
Diameter of Bolts	1/2	5/8	5/8	5/8	3/4	5/8	3/4	3/4	3/4	3/4	3/4	3/4	7/8	–	–

^d 300 lb. Bronze Flanges have plain faces (i.e. not raised faces) with two concentric gasket-retaining grooves between the port and the bolt holes.

PIPE, FITTING & FLANGE SPECIFICATIONS

FLANGE STANDARDS – Dimensional Data in inches (continued)

150 lb. STEEL		ANSI STANDARD B16.5													
PIPE SIZE	1/2	3/4	1	1 1/4	1 1/2	2	2 1/2	3	3 1/2	4	5	6	8	10	12
Diameter of Flange	–	–	4	4 5/8	5	6	7	7 1/2	8 1/2	9	10	11	13 1/2	16	19
Thickness of Flange (min) ^e	–	–	7/16	1/2	9/16	5/8	11/16	3/4	13/16	15/16	15/16	1	1 1/8	1 3/16	1 1/4
Diameter of Raised Face	–	–	2	2 1/2	2 7/8	3 5/8	4 1/8	5	5 1/2	6 3/16	7 5/16	8 1/2	10 5/8	12 3/4	15
Diameter of Bolt Circle	–	–	3 1/8	3 1/2	3 7/8	4 3/4	5 1/2	6	7	7 1/2	8 1/2	9 1/2	11 3/4	14 1/4	17
Number of Bolts	–	–	4	4	4	4	4	4	8	8	8	8	8	12	12
Diameter of Bolts	–	–	1/2	1/2	1/2	5/8	5/8	5/8	5/8	5/8	3/4	3/4	3/4	7/8	7/8

^e 150 lb. Steel Flanges have a 1/16" raised face which is included in the flange thickness dimensions.

300 lb. STEEL		ANSI STANDARD B16.5													
PIPE SIZE	1/2	3/4	1	1 1/4	1 1/2	2	2 1/2	3	3 1/2	4	5	6	8	10	12
Diameter of Flange	–	–	4 7/8	5 1/4	6 1/8	6 1/2	7 1/2	8 1/4	9	10	11	12 1/2	15	17 1/2	20 1/2
Thickness of Flange (min) ^f	–	–	11/16	3/4	13/16	7/8	1	1 1/8	1 3/16	1 1/4	1 3/8	1 7/16	1 5/8	1 7/8	2
Diameter of Raised Face	–	–	2	2 1/2	2 7/8	3 5/8	4 1/8	5	5 1/2	6 3/16	7 5/16	8 1/2	10 5/8	12 3/4	15
Diameter of Bolt Circle	–	–	3 1/2	3 7/8	4 1/2	5	5 7/8	6 5/8	7 1/4	7 7/8	9 1/4	10 5/8	13	15 1/4	17 3/4
Number of Bolts	–	–	4	4	4	8	8	8	8	8	8	12	12	16	16
Diameter of Bolts	–	–	5/8	3/4	5/8	3/4	3/4	3/4	3/4	3/4	3/4	3/4	7/8	1	1 1/8

^f 300 lb. Steel Flanges have a 1/16" raised face which is included in the flange thickness dimensions.

400 lb. STEEL		ANSI STANDARD B16.5													
PIPE SIZE	1/2	3/4	1	1 1/4	1 1/2	2	2 1/2	3	3 1/2	4	5	6	8	10	12
Diameter of Flange	3 3/4	4 5/8	4 7/8	5 1/4	6 1/8	6 1/2	7 1/2	8 1/4	9	10	11	12 1/2	15	17 1/2	20 1/2
Thickness of Flange (min) ^g	9/16	5/8	11/16	13/16	7/8	1	1 1/8	1 1/4	1 3/8	1 3/8	1 1/2	1 5/8	1 7/8	2 1/8	2 1/4
Diameter of Raised Face	1 3/8	1 11/16	2	2 1/2	2 7/8	3 5/8	4 1/8	5	5 1/2	6 3/16	7 5/16	8 1/2	10 5/8	12 3/4	15
Diameter of Bolt Circle	2 5/8	3 1/4	3 1/2	3 7/8	4 1/2	5	5 7/8	6 5/8	7 1/4	7 7/8	9 1/4	10 5/8	13	15 1/4	17 3/4
Number of Bolts	4	4	4	4	4	8	8	8	8	8	8	12	12	16	16
Diameter of Bolts	1/2	5/8	5/8	5/8	3/4	5/8	3/4	3/4	7/8	7/8	7/8	7/8	1	1 1/8	1 1/4

^g 400 lb. Steel Flanges have a 1/4" raised face which is included in the flange thickness dimensions.

600 lb. STEEL		ANSI STANDARD B16.5													
PIPE SIZE	1/2	3/4	1	1 1/4	1 1/2	2	2 1/2	3	3 1/2	4	5	6	8	10	12
Diameter of Flange	3 3/4	4 5/8	4 7/8	5 1/4	6 1/8	6 1/2	7 1/2	8 1/4	9	10 3/4	13	14	16 1/2	20	22
Thickness of Flange (min) ^h	9/16	5/8	11/16	13/16	7/8	1	1 1/8	1 1/4	1 3/8	1 1/2	1 3/4	1 7/8	2 3/16	2 1/2	2 5/8
Diameter of Raised Face	1 3/8	1 11/16	2	2 1/2	2 7/8	3 5/8	4 1/8	5	5 1/2	6 3/16	7 5/16	8 1/2	10 5/8	12 3/4	15
Diameter of Bolt Circle	2 5/8	3 1/4	3 1/2	3 7/8	4 1/2	5	5 7/8	6 5/8	7 1/4	8 1/2	10 1/2	11 1/2	13 3/4	17	19 1/4
Number of Bolts	4	4	4	4	4	8	8	8	8	8	8	12	12	16	20
Diameter of Bolts	1/2	5/8	5/8	5/8	3/4	5/8	3/4	3/4	7/8	7/8	1	1	1 1/8	1 1/4	1 1/4

^h 600 lb. Steel Flanges have a 1/4" raised face which is included in the flange thickness dimensions.

ENGINEERING

PIPE, FITTING & FLANGE SPECIFICATIONS

FITTING STANDARDS & SPECIFICATIONS

Class or Material	Dimensions	Material Spec.	Galvanizing	Thread	Pressure Rating	Federal/Other
Malleable Iron Fittings						
Class 150/PN 20	ASME B16.3•	ASTM A-197	ASTM A-153	ASME B120.1+	ASME B16.3•	ASME B16.3**
Class 300/PN 50	ASME B16.3•	ASTM A-197	ASTM A-153	ASME B120.1+	ASME B16.3•	
Malleable Iron Unions						
Class 150/PN 20	ASME B16.39•	ASTM A-197	ASTM A-153	ASME B120.1+	ASME B16.39•	ASME B16.39***
Class 250	ASME B16.39•	ASTM A-197	ASTM A-153	ASME B120.1+	ASME B16.39•	
Class 300/PN 50	ASME B16.39•	ASTM A-197	ASTM A-153	ASME B120.1+	ASME B16.39•	
Cast Iron Threaded Fittings						
Class 125	ASME B16.4•	ASTM A-126 (A)	ASTM A-153	ASME B120.1+	ASME B16.4•	ASME B16.4◆
Class 250	ASME B16.4•	ASTM A-126 (A)	ASTM A-153	ASME B120.1+	ASME B16.4•	ASME B16.4◆
Cast Iron Plugs & Bushings						
	ASME B16.14•	ASTM A-126 (A)	ASTM A-153	ASME B120.1+	ASME B16.14•	WW-P-471
Cast Iron Drainage Threaded Fittings						
	ASME B16.12•	ASTM A-126 (A)	ASTM A-153	ASME B120.1+	ASME B16.12•	
Cast Iron Flanges & Flanged Fittings						
Class 125 (1 -12)	ASME B16.1•	ASTM A-126 (A) or (B)	ASTM A-153	ASME B120.1+	ASME B16.1•	ASME B16.1•
Class 125 (14 & up)	ASME B16.1•	ASTM A-126 (B)	ASTM A-153	ASME B120.1+	ASME B16.1•	ASME B16.1•
Class 250 (1 -12)	ASME B16.1•	ASTM A-126 (A) or (B)	ASTM A-153	ASME B120.1+	ASME B16.1•	ASME B16.1•
Class 250 (14 & up)	ASME B16.1•	ASTM A-126 (B)	ASTM A-153	ASME B120.1+	ASME B16.1•	ASME B16.1•
Forged Steel Threaded Fittings						
Class 2000, 3000, 6000	ASME B16.11•	ASTM A105, ASTM A182, ASTM A350		ASME B120.1+	ASME B16.11•	
Pipe Nipples						
Steel Pipe - welded	ASTM A733	ASTM A53 Type F or Type E		ASME B120.1+		WWN 351
Steel Pipe - seamless (High Temperature)	ASTM A733	ASTM A106 Gr.B		ASME B120.1+		WWN 351
Brass		ASTM B43		ASME B120.1+		WWN 351

- an American National standard (ANSI)
- + ASME B120.1 was ANSI B2.1
- ◆ Formerly WW-P-501
- ** Formerly WW-P-521
- *** Formerly WW-U-531

PIPE, FITTING & FLANGE SPECIFICATIONS

STANDARD CLASS PRESSURE-TEMPERATURE RATINGS ANSI/ASME B16.34

Working Pressure by Classes	Temperature (°F)	A 216 WCB (a)	A 352 LCB (d)	A 216 WCC (a) A 352 LC2 (d) A 352 LC3 (d) A 352 LCC (e)	A 217 WC1 (b) A 352 LC1 (d)	A 217 WC4 (h) A 217 WC5 (i)	A 217 WC6 (j)	A 217 WC9 (j)	A 217 C5	A 217 C12	A 351 CF3 (f) A 351 CF8	A 351 CF3M (g) A 351 CF8M	A 351 CF8C	A 351 CN7M (l)	
		Working Pressure in PSI													
150 LB.	-20 to 100	285	265	290	265	290	290	290	290	290	275	275	275	230	
	200	260	250	260	260	260	260	260	260	260	235	240	245	215	
	300	230	230	230	230	230	230	230	230	230	205	215	225	200	
	400	200	200	200	200	200	200	200	200	200	180	195	200	185	
	500	170	170	170	170	170	170	170	170	170	170	170	170	170	
	600	140	140	140	140	140	140	140	140	140	140	140	140	140	
	650	125	125	125	125	125	125	125	125	125	125	125	125	125	
	700	110	110	110	110	110	110	110	110	110	110	110	110	110	
	750	95	95	95	95	95	95	95	95	95	95	95	95	95	
	800	80	80	80	80	80	80	80	80	80	80	80	80	80	
	850	65	65	65	65	65	65	65	65	65	65	65	65	-	
	900	50	50	50	50	50	50	50	50	50	50	50	50	-	
	950	35	35	35	35	35	35	35	35	35	35	35	35	-	
	1000	20	20	20	20	20	20	20	20	20	20	20	20	-	
	1050	-	-	-	-	-	20(1)	20(1)	20(1)	20(1)	20(1)	20(1)	20(1)	20(1)	-
	1100	-	-	-	-	-	-	20(1)	20(1)	20(1)	20(1)	20(1)	20(1)	20(1)	-
	1150	-	-	-	-	-	-	20(1)	20(1)	20(1)	20(1)	20(1)	20(1)	20(1)	-
	1200	-	-	-	-	-	-	15(1)	20(1)	20(1)	20(1)	20(1)	20(1)	20(1)	-
	1250	-	-	-	-	-	-	-	-	-	-	20(1)	20(1)	20(1)	-
	1300	-	-	-	-	-	-	-	-	-	-	20(1)	20(1)	20(1)	-
1350	-	-	-	-	-	-	-	-	-	-	20(1)	20(1)	20(1)	-	
1400	-	-	-	-	-	-	-	-	-	-	20(1)	20(1)	20(1)	-	
1450	-	-	-	-	-	-	-	-	-	-	15(1)	20(1)	20(1)	-	
1500	-	-	-	-	-	-	-	-	-	-	10(1)	15(1)	15(1)	-	
300 LB.	-20 to 100	740	695	750	695	750	750	750	750	750	720	720	720	600	
	200	675	655	750	680	750	710	715	750	750	600	620	635	555	
	300	655	640	730	655	730	675	675	730	730	530	560	590	525	
	400	635	620	705	640	705	660	650	705	705	470	515	555	480	
	500	600	585	665	620	665	640	640	665	665	435	480	520	470	
	600	550	535	605	605	605	605	605	605	605	415	450	490	455	
	650	535	525	590	590	590	590	590	590	590	410	445	480	450	
	700	535	520	570	570	570	570	570	570	570	405	430	470	445	
	750	505	475	505	530	530	530	530	530	530	400	425	460	440	
	800	410	390	410	510	510	510	510	510	510	395	415	455	430	
	850	270	270	270	485	485	485	485	440	485	390	405	445	-	
	900	170	170	170	450	450	450	450	355	450	385	395	430	-	
	950	105	105	105	280	345	380	380	260	370	375	385	385	-	
	1000	50	50	50	165	215	225	270	190	290	325	365	365	-	
	1050	-	-	-	-	190	140	200	140	190	310	360	360	-	
	1100	-	-	-	-	-	-	95	115	105	115	260	325	325	-
	1150	-	-	-	-	-	-	50	105	70	75	195	275	275	-
	1200	-	-	-	-	-	-	35	55	45	50	155	205	170	-
	1250	-	-	-	-	-	-	-	-	-	-	110	180	125	-
	1300	-	-	-	-	-	-	-	-	-	-	85	140	95	-
1350	-	-	-	-	-	-	-	-	-	-	60	105	70	-	
1400	-	-	-	-	-	-	-	-	-	-	50	75	50	-	
1450	-	-	-	-	-	-	-	-	-	-	35	60	40	-	
1500	-	-	-	-	-	-	-	-	-	-	25	40	35	-	

ENGINEERING

PIPE, FITTING & FLANGE SPECIFICATIONS

STANDARD CLASS PRESSURE-TEMPERATURE RATINGS ANSI/ASME B16.34 (continued)

Working Pressure by Classes	Temperature (°F)	A 216 WCB (a)	A 352 LCB (d)	A 216 WCC (a) A 352 LC2 (d) A 352 LC3 (d) A 352 LCC (e)	A 217 WC1 (b) A 352 LC1 (d)	A 217 WC4 (h) A 217 WC5 (i)	A 217 WC6 (j)	A 217 WC9 (j)	A 217 C5	A 217 C12	A 351 CF3 (f) A 351 CF8	A 351 CF3M (g) A 351 CF8M	A 351 CF8C	A 351 CN7M (l)
		Working Pressure in PSI												
400 LB.	-20 to 100	990	925	1000	925	1000	1000	1000	1000	1000	960	960	960	800
	200	900	875	1000	905	1000	950	955	1000	1000	800	825	850	740
	300	875	850	970	870	970	895	905	970	970	705	745	785	700
	400	845	825	940	855	940	880	865	940	940	630	685	740	640
	500	800	775	885	830	885	855	855	885	885	585	635	690	625
	600	730	710	805	805	805	805	805	805	805	555	600	655	605
	650	715	695	785	785	785	785	785	785	785	545	590	640	600
	700	710	690	755	755	755	755	755	755	755	540	575	625	595
	750	670	630	670	710	710	710	710	710	710	530	565	615	585
	800	550	520	550	675	675	675	675	675	675	525	555	610	575
	850	355	355	355	650	650	650	650	585	650	520	540	590	-
	900	230	230	230	600	600	600	600	470	600	510	525	575	-
	950	140	140	140	375	460	505	505	350	495	500	515	515	-
	1000	70	70	70	220	285	300	355	255	390	430	485	485	-
	1050	-	-	-	-	250	185	265	190	250	410	480	480	-
	1100	-	-	-	-	-	130	150	140	150	345	430	430	-
	1150	-	-	-	-	-	70	140	90	100	260	365	365	-
	1200	-	-	-	-	-	45	75	60	70	205	275	230	-
	1250	-	-	-	-	-	-	-	-	-	145	245	165	-
	1300	-	-	-	-	-	-	-	-	-	110	185	125	-
1350	-	-	-	-	-	-	-	-	-	85	140	90	-	
1400	-	-	-	-	-	-	-	-	-	65	100	70	-	
1450	-	-	-	-	-	-	-	-	-	45	80	55	-	
1500	-	-	-	-	-	-	-	-	-	30	55	45	-	
600 LB.	-20 to 100	1480	1390	1500	1390	1500	1500	1500	1500	1500	1440	1440	1440	1200
	200	1350	1315	1500	1360	1500	1425	1430	1500	1500	1200	1240	1270	1115
	300	1315	1275	1455	1305	1455	1345	1355	1455	1455	1055	1120	1175	1045
	400	1270	1235	1410	1280	1410	1315	1295	1410	1410	940	1030	1110	960
	500	1200	1165	1330	1245	1330	1285	1280	1330	1330	875	955	1035	935
	600	1095	1065	1210	1210	1210	1210	1210	1210	1210	830	905	985	910
	650	1075	1045	1175	1175	1175	1175	1175	1175	1175	815	890	960	900
	700	1065	1035	1135	1135	1135	1135	1135	1135	1135	805	865	935	890
	750	1010	945	1010	1065	1065	1065	1065	1065	1065	795	845	920	880
	800	825	780	825	1015	1015	1015	1015	1015	1015	790	830	910	865
	850	535	535	535	975	975	975	975	880	975	780	810	890	-
	900	345	345	345	900	900	900	900	705	900	770	790	865	-
	950	205	205	205	560	685	755	755	520	740	750	775	775	-
	1000	105	105	105	330	425	445	535	385	585	645	725	725	-
	1050	-	-	-	-	380	275	400	280	380	620	720	720	-
	1100	-	-	-	-	-	190	225	205	225	515	645	645	-
	1150	-	-	-	-	-	105	205	140	150	390	550	550	-
	1200	-	-	-	-	-	70	110	90	105	310	410	345	-
	1250	-	-	-	-	-	-	-	-	-	220	365	245	-
	1300	-	-	-	-	-	-	-	-	-	165	275	185	-
1350	-	-	-	-	-	-	-	-	-	125	205	135	-	
1400	-	-	-	-	-	-	-	-	-	95	150	105	-	
1450	-	-	-	-	-	-	-	-	-	70	115	80	-	
1500	-	-	-	-	-	-	-	-	-	50	85	70	-	

PIPE, FITTING & FLANGE SPECIFICATIONS

STANDARD CLASS PRESSURE-TEMPERATURE RATINGS ANSI/ASME B16.34 (continued)

Working Pressure by Classes	Temperature (°F)	A 216 WCB (a)	A 352 LCB (d)	A 216 WCC (a) A 352 LC2 (d) A 352 LC3 (d) A 352 LCC (e)	A 217 WC1 (b) A 352 LC1 (d)	A 217 WC4 (h) A 217 WC5 (i)	A 217 WC6 (j)	A 217 WC9 (j)	A 217 C5	A 217 C12	A 351 CF3 (f) A 351 CF8	A 351 CF3M (g) A 351 CF8M	A 351 CF8C	A 351 CN7M (l)
		Working Pressure in PSI												
900 LB.	-20 to 100	2220	2085	2250	2085	2250	2250	2250	2250	2250	2160	2160	2160	1800
	200	2025	1970	2250	2035	2250	2135	2150	2250	2250	1800	1860	1910	1670
	300	1970	1915	2185	1955	2185	2020	2030	2185	2185	1585	1680	1765	1570
	400	1900	1850	2115	1920	2115	1975	1945	2115	2115	1410	1540	1665	1445
	500	1795	1745	1995	1865	1995	1925	1920	1995	1995	1310	1435	1555	1405
	600	1640	1600	1815	1815	1815	1815	1815	1815	1815	1245	1355	1475	1365
	650	1610	1570	1765	1765	1765	1765	1765	1765	1765	1225	1330	1440	1350
	700	1600	1555	1705	1705	1705	1705	1705	1705	1705	1210	1295	1405	1335
	750	1510	1420	1510	1595	1595	1595	1595	1595	1595	1195	1270	1385	1320
	800	1235	1175	1235	1525	1525	1525	1525	1490	1525	1180	1245	1370	1295
	850	805	805	805	1460	1460	1460	1460	1315	1460	1165	1215	1330	-
	900	515	515	515	1350	1350	1350	1350	1060	1350	1150	1180	1295	-
	950	310	310	310	845	1030	1130	1130	780	1110	1125	1160	1160	-
	1000	155	155	155	495	640	670	805	575	875	965	1090	1090	-
	1050	-	-	-	-	565	410	595	420	565	925	1080	1080	-
	1100	-	-	-	-	-	290	340	310	340	770	965	965	-
	1150	-	-	-	-	-	155	310	205	225	585	825	825	-
	1200	-	-	-	-	-	105	165	135	155	465	620	515	-
	1250	-	-	-	-	-	-	-	-	-	330	545	370	-
	1300	-	-	-	-	-	-	-	-	-	245	410	280	-
1350	-	-	-	-	-	-	-	-	-	185	310	205	-	
1400	-	-	-	-	-	-	-	-	-	145	225	155	-	
1450	-	-	-	-	-	-	-	-	-	105	175	125	-	
1500	-	-	-	-	-	-	-	-	-	70	125	105	-	
1500 LB.	-20 to 100	3705	3470	3750	3470	3750	3750	3750	3750	3750	3600	3600	3600	3000
	200	3375	3280	3750	3395	3750	3560	3580	3750	3750	3000	3095	3180	2785
	300	3280	3190	3640	3260	3640	3365	3385	3640	3640	2640	2795	2940	2615
	400	3170	3085	3530	3200	3530	3290	3240	3530	3530	2350	2570	2770	2405
	500	2995	2910	3325	3105	3325	3210	3200	3325	3325	2185	2390	2590	2340
	600	2735	2665	3025	3025	3025	3025	3025	3025	3025	2075	2255	2460	2275
	650	2685	2615	2940	2940	2940	2940	2940	2940	2940	2040	2220	2400	2250
	700	2665	2590	2840	2840	2840	2840	2840	2840	2840	2015	2160	2340	2225
	750	2520	2365	2520	2660	2660	2660	2660	2660	2660	1990	2110	2305	2200
	800	2060	1955	2060	2540	2540	2540	2540	2485	2540	1970	2075	2280	2160
	850	1340	1340	1340	2435	2435	2435	2435	2195	2435	1945	2030	2220	-
	900	860	860	860	2245	2245	2245	2245	1765	2245	1920	1970	2160	-
	950	515	515	515	1405	1715	1885	1885	1305	1850	1870	1930	1930	-
	1000	260	260	260	825	1065	1115	1340	960	1460	1610	1820	1820	-
	1050	-	-	-	-	945	684	995	705	945	1545	1800	1800	-
	1100	-	-	-	-	-	480	565	515	565	1285	1610	1610	-
	1150	-	-	-	-	-	260	515	345	380	980	1370	1370	-
	1200	-	-	-	-	-	170	275	225	260	770	1030	855	-
	1250	-	-	-	-	-	-	-	-	-	550	910	615	-
	1300	-	-	-	-	-	-	-	-	-	410	685	465	-
1350	-	-	-	-	-	-	-	-	-	310	515	345	-	
1400	-	-	-	-	-	-	-	-	-	240	380	255	-	
1450	-	-	-	-	-	-	-	-	-	170	290	205	-	
1500	-	-	-	-	-	-	-	-	-	120	205	170	-	

Note: For welding end valves only.
(1) Flanged end ratings terminate at 1000 °F.

- Footnotes:**
- a) Permissible, but not recommended for prolonged usage above about 800 °F.
 - b) Permissible, but not recommended for prolonged usage above about 850 °F.
 - d) Not to be used over 650 °F.
 - e) Not to be used over 700 °F.
 - f) Not to be used over 800 °F.
 - g) Not to be used over 850 °F.
 - h) Not to be used over 1000 °F.
 - i) Not to be used over 1050 °F.
 - j) Not to be used over 1100 °F.
 - l) Ratings apply for 300 °F and lower.

INTRODUCTION TO STEAM TRAPS

WHAT IS A STEAM TRAP AND WHAT DOES IT DO?

A steam trap is an automatic valve that allows condensate, air and other non-condensable gases to be discharged from the steam system while holding or trapping the steam in the system. Several different types of steam trap technologies exist to accomplish this extremely critical and necessary task. Explained below are why steam traps are required, their primary applications, how each type functions, their advantages and disadvantages, and when each should be applied.

WHY ARE STEAM TRAPS REQUIRED?

For any steam system to operate properly a method must be used to remove the condensate, air and other non-condensable gases such as carbon dioxide from the steam.

CONDENSATE:

When steam releases its heat energy in a heat exchanger making hot water, from a radiator heating a room, from a steam pipe transferring steam or from any process application, the steam reverts back to water. This water, technically referred to as *condensate*, must be separated from the steam and removed from the system or the system would back up with water. The removal of condensate from steam is considered the primary function of the steam trap.

AIR:

Air exists in all steam pipes prior to system start-up when the system is cold. This air must be bled out of the piping system so that the steam can enter and eventually reach the designated process applications. If the air is not removed, the steam will effectively be blocked from entering the steam pipes by the residual air. In addition to blocking the steam, air acts as an insulator to heat transfer. Even after the system is filled with steam, small amounts of air can re-enter the system through various paths such as boiler water make-up systems and vacuum breakers.

NON-CONDENSABLE GASES:

Gases other than air such as carbon dioxide exist inside steam systems. These non-condensable gases must also be separated from the steam and removed from the system for all processes to operate properly. In addition to inhibiting steam flow and proper heat transfer, carbon dioxide can be very corrosive to components in the system.

STEAM TRAP GENERAL APPLICATION CATEGORIES:

DRIP APPLICATIONS:

Drip applications are by far the most common application for steam traps. This application refers to removing the condensate that forms in steam lines when steam loses its heat energy due to radiation losses. Traps used in these applications are referred to as *drip traps*. Generally speaking, traps used for these applications require relatively small condensate capacities and don't normally need to discharge large amounts of air. (Air removal is the primary function of air vents and process traps located throughout the system.) The most common trap choices for drip applications are *thermodynamic* for line pressures over 30 PSIG, and *float & thermostatic* for line pressures up to 30 PSIG. Inverted bucket traps are also commonly used for drip trap applications due to their ability to handle large amounts of dirt and scale often found in this type of application.

PROCESS APPLICATIONS:

Process trap applications refer to removing condensate and air directly from a specific heat transfer process such as a heat exchanger that could be making hot water or a radiator heating a room. Traps used in these applications are referred to as *process traps*. Generally speaking, traps used for process applications require larger condensate handling capability and also need to be able to discharge large amounts of air. The most common trap choices for process applications are *float & thermostatic* traps and *thermostatic* traps. Both are known for their excellent condensate and air handling capabilities. In contrast, thermodynamic traps and inverted bucket traps, which have poor air handling ability, would normally make a poor choice for process applications.

TRACING APPLICATIONS:

Steam tracing refers to using steam to indirectly elevate the temperature of a product using jacketed pipes or tubing filled with steam. A typical application would be wrapping a high viscosity oil pipeline with steam tubing. The steam inside the tubing heats the oil to lower its viscosity, allowing it to flow easily through the pipeline. Similar to any steam applications, a steam trap must be used on the end of the steam tubing to discharge unwanted condensate. Steam traps used in these applications are referred to as *tracer traps*. The most common trap choice for tracing applications is the *thermostatic* type.

STEAM TRAP APPLICATIONS

THERMOSTATIC & BI-METALLIC STEAM TRAPS

Thermostatic & Bi-Metallic steam traps operate under the direct influence of increasing or decreasing temperature within the body of the trap. These two different types of steam traps operate differently to suit specific applications.

THERMOSTATIC STEAM TRAPS

The bellows type thermostatic trap uses a fluid-filled thermal element (bellows) that operates under the principle of thermal expansion and contraction. The fluid vaporizes and expands as the temperature increases, causing the bellows to close the valve. As the temperature decreases, the fluid condenses and contracts, causing the bellows to open the valve. These traps provide excellent air handling capability and are used for drip, tracing and process applications. The main advantage of the thermal element is that on start-up loads, the trap is in the open position, allowing air and condensate to be rapidly removed from the system. Watson McDaniel thermal element traps offer wide operating pressure ranges, rugged welded stainless steel bellows, and various orifice sizes, making them a great choice for a majority of applications.

Operation:

The operation of the thermal element is governed by the volumetric thermal expansion of the fluid inside the bellows as it changes states. There is no adjustment required for this trap as the fluid inside the bellows is chosen for its quick response to the change in temperature between steam and condensate at various pressures. The bellows is designed to follow the steam saturation curve, always discharging condensate a few degrees cooler than the steam temperature. During start-up, when the system is cold, the bellows is contracted and the valve plug is lifted off of the seat allowing air and condensate to be discharged from the system (Figures 1A & 1B). Throughout warm-up, air and condensate are allowed to escape from the system through the open orifice in the trap. As hot steam approaches the thermal element in the trap, the fluid inside the bellows vaporizes and expands, closing the valve tightly (Figure 1C). As long as steam is present, the valve will remain closed. Only when subcooled condensate or air is present will the valve open. The bellows will immediately expand and close the valve upon the reintroduction of steam.

Figure 1:

A) AIR (When air, which is cooler than steam, is present, the bellows is retracted and the seat is open, allowing large quantities of air to be discharged.)

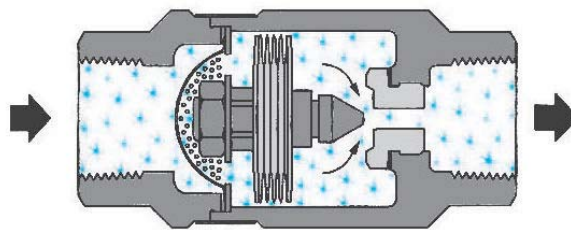

B) CONDENSATE (When condensate, which is cooler than steam, is present, the bellows is retracted and the seat is open, allowing condensate to be discharged.)

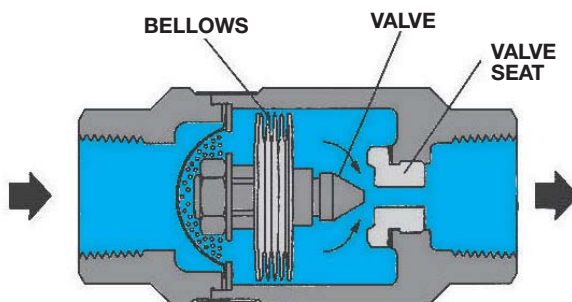

C) STEAM (When steam reaches the trap, the bellows expands, which closes off the seat and prevents the steam from escaping.)

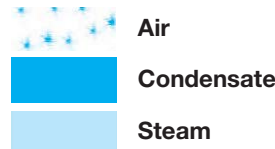
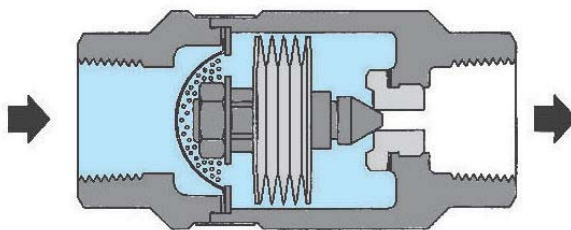

BI-METALLIC STEAM TRAPS

The bi-metallic steam traps operate under the principle of thermal expansion of metals. Two dissimilar metals are joined into a series of discs and upon heating will deflect to provide movement to close off the valve. These traps are primarily used in steam tracing because of their ability to adjust condensate discharge temperature which may be desirable on certain tracing applications.

When cold condensate and air are present, the bimetallic trap remains open as the flow of air and condensate discharges from the system. When steam arrives to the trap, the discs deflect and pushes the plug onto the seat. The temperature at which the valve closes can be adjusted by turning a set screw located on the top of the valve.

STEAM TRAP APPLICATIONS

MECHANICAL STEAM TRAPS

Mechanical steam traps operate by use of a float device connected to a mechanical linkage that reacts upon changes in volume or fluid density. There are two main types of mechanical traps: the *float & thermostatic* (F&T) trap and the *inverted bucket* trap.

FLOAT & THERMOSTATIC TRAPS

The float & thermostatic trap uses a float connected by a linkage to the valve plug to discharge condensate from the system. In addition, F&T traps contain a thermostatic air vent to allow the discharge of air from the system. For this reason, these traps have excellent air removal capability, which is advantageous during system start-up when large amounts of air are present in the system. Float & thermostatic steam traps are generally the primary selection for drainage of process heat transfer equipment.

Operation:

At start-up, air and condensate enter the steam trap. The air will be discharged through the open thermostatic air vent (**Figure 2A**). As the condensate level in the trap rises, it lifts the float which opens the valve to allow the discharge of condensate. When steam enters the trap, the thermostatic element expands and closes the air vent, preventing the steam from escaping (**Figure 2B**). As the condensate discharges through the seat orifice, the float lowers and shuts the valve (**Figure 2C**). The float is designed to shut the valve with a level of condensate above the seating orifice to prevent loss of any steam. The float modulates to maintain a constant equilibrium between the incoming and discharging condensate. Due to the balance of forces required between the incoming pressure and internal trap components, several orifice sizes are offered to accommodate various differential pressure ranges. These traps can be fitted with a steam lock release (SLR) orifice for high pressure and high temperature applications that exceed the pressure capability of a thermostatic air vent.

Figure 2:

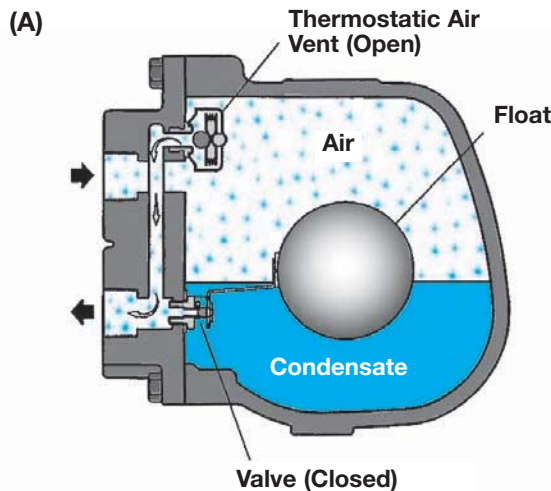

A) When cold air enters the trap during start-up, the thermostatic air vent is open, allowing the discharge of large quantities of air from the system.

B) When condensate enters the trap, the float lifts, opening the valve, and discharges the condensate.

C) When steam is present, and no condensate is entering the trap, the valve and thermostatic air vent remain closed, trapping steam in the system.

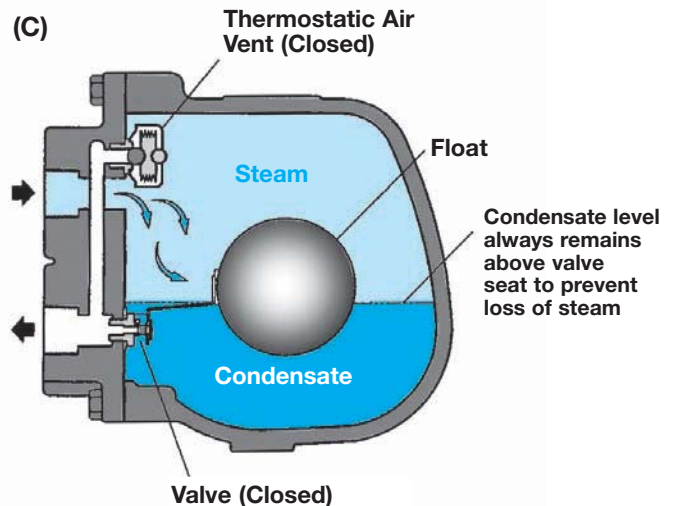
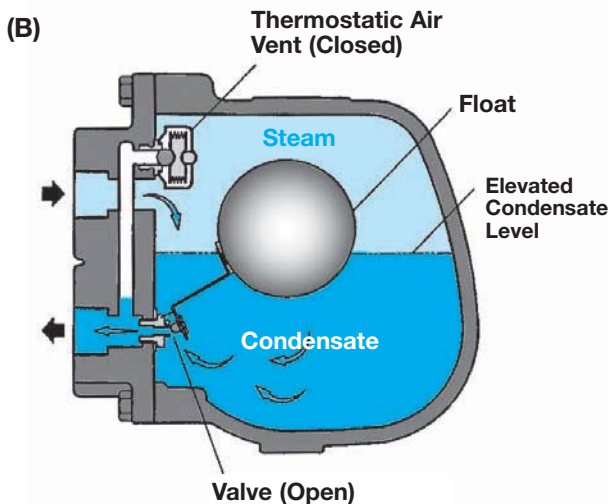

INVERTED BUCKET TRAPS

The inverted bucket trap uses an inverted bucket as a float device connected by a linkage to the valve plug. The varying densities between condensate and steam are used to create a buoyancy force on the bucket to open and close the valve. These traps are primarily used in drip applications on steam mains and steam supply lines. They are generally not used in process applications due to their poor air handling capability. Bucket traps are extremely rugged and resistant to waterhammer and also resistant to any dirt and scale that may be present in the system.

Operation:

Upon start-up, the trap fills with condensate. Due to the weight of the bucket, it rests on the bottom of the trap keeping the valve open to let condensate flow out (**Figure 3A**). In the top of the bucket there is a small orifice (bleed hole) to allow air to escape the bucket and exit through the outlet (**Figure 3B**). When steam arrives through the inlet of the trap, it fills the inverted bucket. The density differential between the steam and the condensate causes the bucket to become buoyant and rise to the top of the trap, closing the valve (**Figure 3C**). As steam condenses and/or is bled through the small orifice, the bucket loses buoyancy as it becomes filled with condensate; this causes it to sink to the bottom of the trap. This opens the valve allowing condensate to escape from the system (**Figure 3A**). The small orifice in the top of the bucket is imperative for venting air from the system; however, it will also bleed steam once the air has been completely removed. The bucket trap must contain a certain amount of water (prime) in order to operate. Without this prime, the bucket will not be able to float and rest on the bottom of the trap, keeping the valve in the open position, allowing steam to escape (**Figure 3D**). Due to the balance of forces required between the incoming pressure and internal trap components, several orifice sizes are offered to accommodate various differential pressure ranges.

Figure 3:

(A) Discharging Condensate

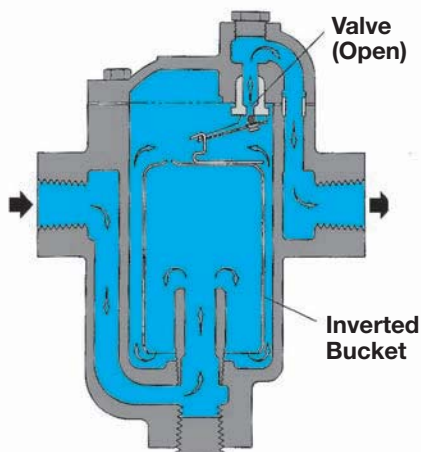

(B) Expelling Air

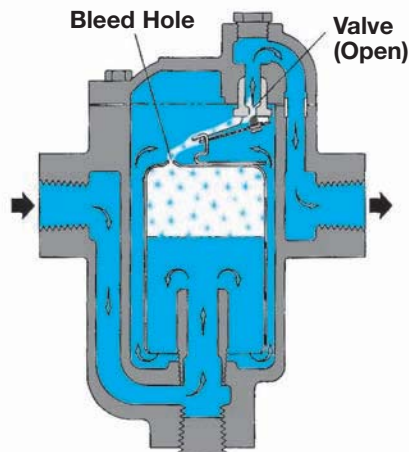

(C) Trapping Steam

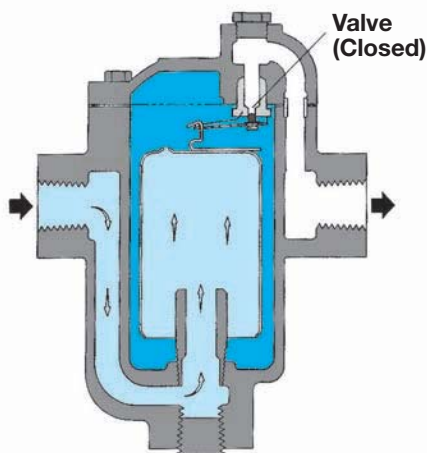

(D) Potential Failure Mode

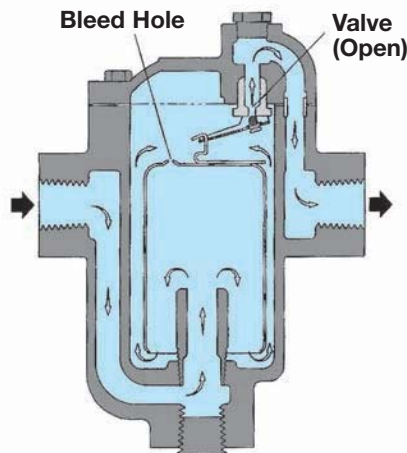

A) With condensate completely filling the trap, the bucket is in the down position with the valve open, allowing condensate to be discharged.

B) Small amounts of air will pass thru the bleed hole on top of the bucket and be discharged. (Note: Large amounts of air will lift the bucket and close off the trap, temporarily air locking the system.)

C) When steam enters the trap, the inverted bucket will fill with steam and float, closing off the valve, preventing steam from escaping.

D) Potential Failure Mode: Bucket traps must maintain a water prime to function properly. If the prime is lost, the bucket will remain in the down position with the valve open, and live steam will be discharged from the system.

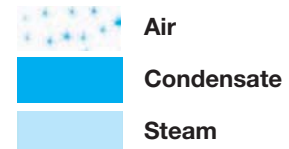

THERMODYNAMIC STEAM TRAPS

THERMODYNAMIC STEAM TRAPS

Thermodynamic steam traps operate in a cyclic on/off process using the thermodynamic properties of flash steam as it flows through the trap. Thermodynamic traps use only one moving part, the valve disc, which allows condensate to escape when present and closes tightly upon the arrival of steam. These traps have an inherently rugged design and are commonly used as drip traps on steam mains and supply lines. Their solid construction and single moving part make them resistant to waterhammer and are freezeproof when installed vertically. Thermodynamic traps will only discharge small amounts of air and therefore are typically not used in process applications.

Operation:

As inlet pressure to the trap increases, the disc lifts off the seat and allows the unwanted condensate to escape through the peripheral outlet surrounding the inlet (**Figure 4A**). As hot condensate reaches the disc chamber, it creates flash steam in the chamber (**Figure 4B**). This flash steam travels at high velocity from the inlet to the outlets, creating a low pressure area under the disc. Some of the flash steam bypasses the disc and enters the top of the chamber, creating a buildup of pressure above the disc. This differential pressure causes the disc to close against the seat, trapping the steam (**Figure 4C**). The flash steam above the disc is the only force opposing the pressure from the inlet condensate, keeping the valve closed. As heat transfer takes place in the upper chamber, the flash steam condenses and the pressure above the disc reduces. When the pressure above the disc falls to a point that is less than the pressure of the incoming condensate, the disc will lift again and repeat the cycle (**Figure 4A**). Cycle time is dependent on steam temperature, and more importantly, ambient temperature outside the trap. Since the amount of time the valve is closed is primarily dependent on the heat transfer from the flash steam to the ambient environment, frequent cycling of the valve can occur in cold or wet environments. Applying an insulating cap over the cover of the trap will reduce the cycle rate.

Figure 4:

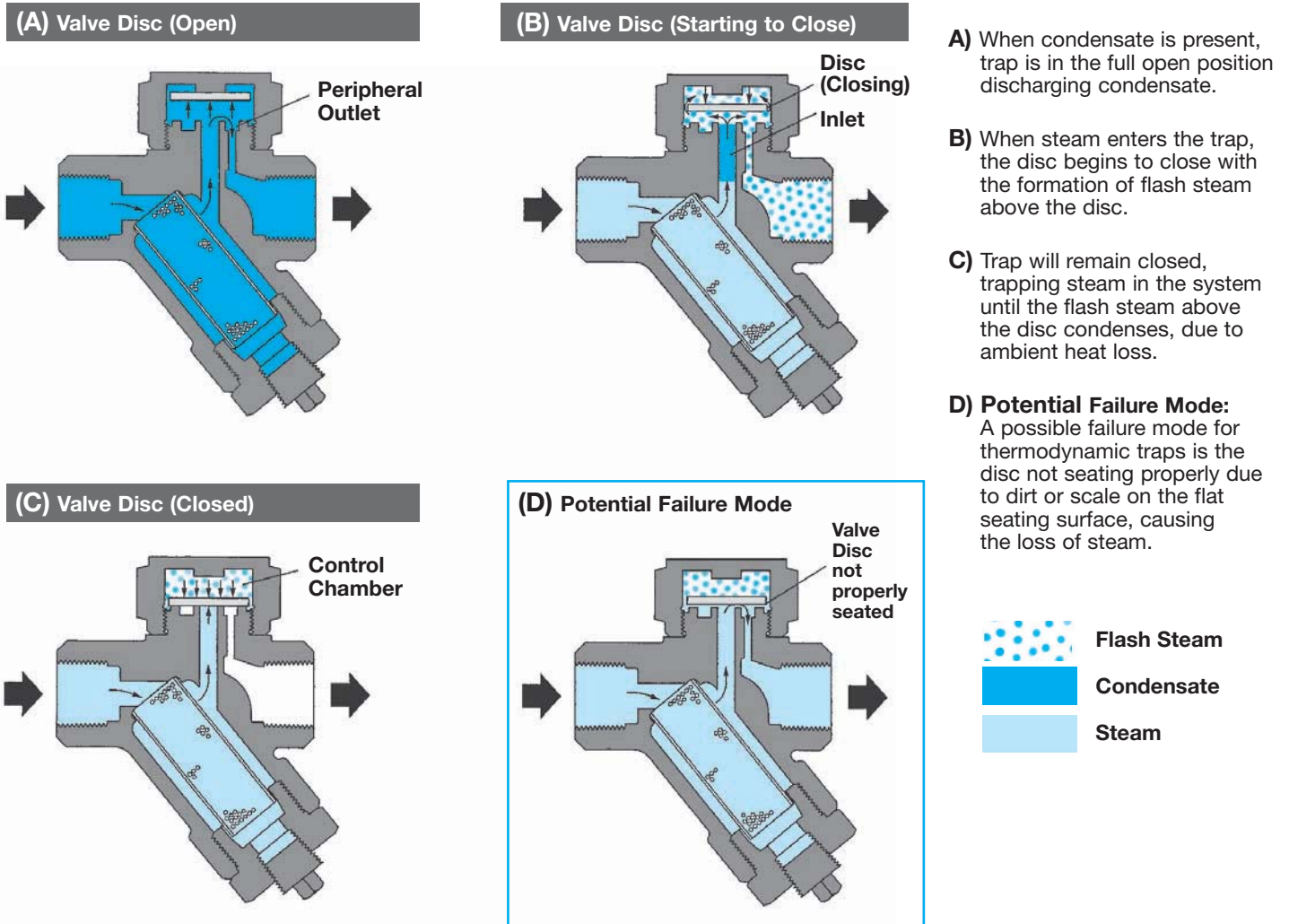

Selection & Sizing of Steam Traps & Safety Factors:

The type of steam trap to choose for a particular application can depend on several variables, making it difficult to effectively cover every factor involved in making a proper decision. However, the guidelines below should assist you in making a proper and logical selection.

For any type of **process applications**, such as making hot water in a heat exchanger, we generally want a steam trap that is very good at discharging air as well as condensate. Therefore, a float & thermostatic (F&T) trap is typically the first choice of steam trap. However, thermostatic steam traps, such as the WT3000 and WT4000, which have been designed for process applications, also do an excellent job and are very commonly used. Both types of traps will generally satisfy most process applications.

For **drip applications**, such as draining steam mains over 30 PSIG, thermodynamic traps are normally considered the first choice. In drip applications it's not as critical of a requirement to remove air from the system since this is normally the function of separate thermostatic air vents placed in strategic places in the piping system and the process traps. However, for steam systems up to 30 PSIG, F&T traps are normally recommended. For steam systems that are known to contain large amounts of scale and dirt, bucket traps are recommended because they are less prone than thermodynamic and F&T traps to failure from this type of situation.

For **tracing applications**, the most commonly used steam trap is the thermostatic type. Thermostatic traps are the most thermally efficient of all traps and lend themselves perfectly to this type of application.

The capacity of steam traps:

The capacity charts for steam traps give the maximum condensate flow in pounds per hour at a given pressure or pressure differential. When selecting the proper size of steam trap, the normal condensate rate (load) should be known and then multiplied by an appropriate safety factor.

Why safety factors need to be considered:

A safety factor is required because the amount of condensate generated and the steam pressure are not always constant in any steam system. For example, when the system is cold and steam first starts to flow thru the pipes, steam is condensing very quickly because of the massive heat required to heat all the cold surfaces as well as to overcome the radiation losses. To compound this issue further, the steam pressure in the system, which is being relied upon to push the condensate thru the steam trap into the return line, is extremely low before the system comes up to full pressure. Therefore, we have a condition in which the condensate in the system is being generated at a maximum rate and the steam pressure used to push the condensate out of the system, is at a minimum. If we sized the traps for the normal running loads and normal system pressures, these traps would be severely undersized for the start-up condition. If supervised start-ups of the steam system are being done then sizing the steam traps for start-up conditions may be less of an issue. When performing a supervised start-up of a cold system, the condensate drain valves that are strategically placed throughout the system are manually opened. This helps drain the massive amount of condensate that is generated by the cold piping system, relying less on the steam traps. Therefore, the steam traps selected for the system can be more properly sized for the actual normal running load if supervised start-ups are performed.

Recommended Steam Trap Selection & Safety Factors for Sizing:

APPLICATIONS	PRIMARY TRAP CHOICE	SAFETY FACTORS & SPECIAL NOTES
Drip Trap on Steam Mains ≤ 30 PSIG	Float & Thermostatic	Trap should be sized for 2X normal capacity at full differential pressure
Drip Trap on Steam Mains > 30 PSIG	Thermodynamic	
Steam Tracing, Non-critical	Thermostatic	Thermostatic traps are suitable for the majority of steam tracing applications; for critical steam tracing applications, where no back-up of condensate can be tolerated, thermodynamic traps should be used.
Steam Tracing, Critical	Thermodynamic	
Process applications up to 450 PSIG	Float & Thermostatic	For steam systems with <u>constant</u> pressure: Trap should be sized for 2X normal capacity at full differential pressure. For steam systems with <u>modulating</u> pressure: When draining condensate from heat exchangers operating up to 30 PSIG, steam traps should be sized for full capacity at 1/2 PSI differential pressure. When draining condensate from heat exchangers operating at over 30 PSIG, steam trap should be sized for 2.5X normal condensate load at full differential pressure.

STEAM TRAP APPLICATIONS

DRIP LEG DESIGN

PURPOSE: Drip Legs are used for removing entrained moisture from steam transmission and distribution lines to ensure high quality steam for use in various plant applications, while also preventing damaging and dangerous waterhammer.

OPERATION: As steam travels at high velocity through piping, moisture forms as the result of piping heat losses and/or improper boiler control resulting in condensate carryover. Drip legs are therefore located at points where condensate may accumulate to allow for drainage by gravity down to a steam trap for proper discharge from the system. Since condensate drains by gravity, drip legs must be located on the bottom of piping and designed with diameters large enough to promote collection.

INSTALLATION GUIDELINES: (see Figure 5)

- For drainage of steam transmission and distribution lines, drip legs should be located at bends in piping (direction changes), low points, end of line, and in straight run of piping every 200 feet.
- For protection of equipment such as regulators and control valves, drip legs should be installed directly ahead of the regulating or control valve line.
- Proper steam trap selection for drip applications is dependent upon application requirements, such as pressure, number of and distance between installed steam traps, ambient conditions, start-up requirements, etc. A commonly accepted practice is to use float & thermostatic (F&T) steam traps for low pressure steam systems up to 30 PSIG, and thermodynamic steam traps for steam pressures over 30 PSIG.
- Because condensate drainage from steam systems is dependent upon gravity, drip leg diameter is critical for optimum removal – larger is better. Collection leg diameter (D_L) is recommended to be the same size as the steam main (D), up to 4". For steam mains above 4", the collection leg diameter may be half the diameter of the main, but not less than 4". The length (L) of the drip leg for systems with automatic start-up should be a minimum of 28" to provide approximately 1 PSI head pressure. The length (L) of the drip leg for systems with supervised start-up should be $1.5 \times D_L$, but not less than 8".
- Consider low-cracking pressure (1/4 PSI opening pressure) check valves after steam traps when discharging into condensate return lines. Check valves eliminate the possibility of condensate backing up through the steam trap into the system.
- A drain valve is included at the bottom of the collection leg for manual discharge of condensate during supervised start-up. The drain valve should be located at least 6" below the steam trap line.
- An isolation valve and strainer should be installed before the steam trap. The isolation valve simplifies maintenance of the trap and the strainer protects the trap from any dirt, debris or scale in the line.

Figure 5:

DRIP LEG DESIGN CRITERIA:

- 1) Locate prior to valves, bends in pipe (direction changes), low points, end of line and straight piping runs (max. 200 ft. apart).
- 2) Diameter:
 - Drip leg diameter (D_L) to be equal to steam main diameter (D) for steam main sizes up to 4"
 - Drip leg diameter (D_L) may be half the steam main diameter (D) for steam main sizes over 4", but not less than 4"
- 3) Length (L):
 - For systems with automatic start-up, L to be 28" minimum (= 1 PSI minimum head pressure)
 - For systems with supervised start-up, L to be $1.5 \times D_L$, but not less than 8"

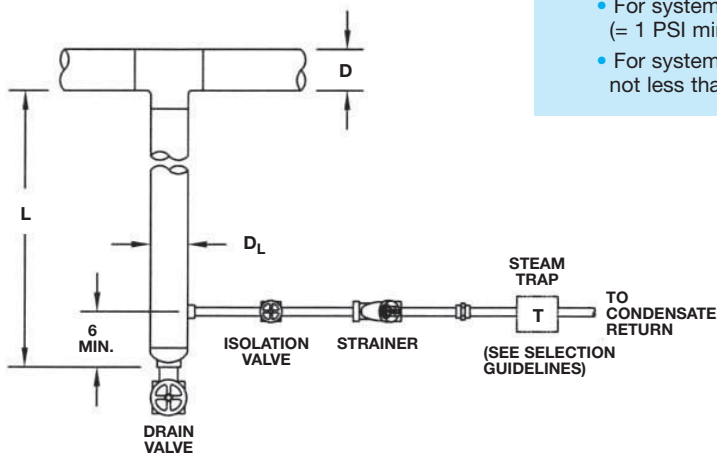

PROPER DRIP LEG DESIGN

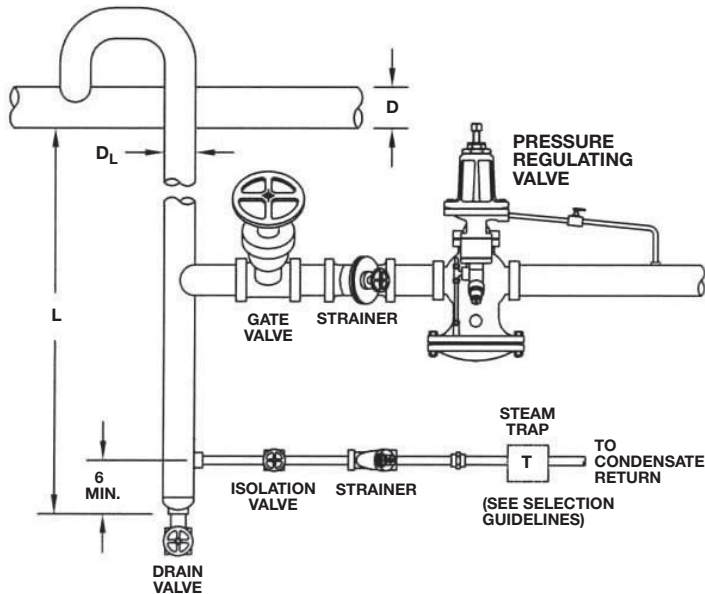

DRIP LEG BEFORE REGULATING OR CONTROL VALVES

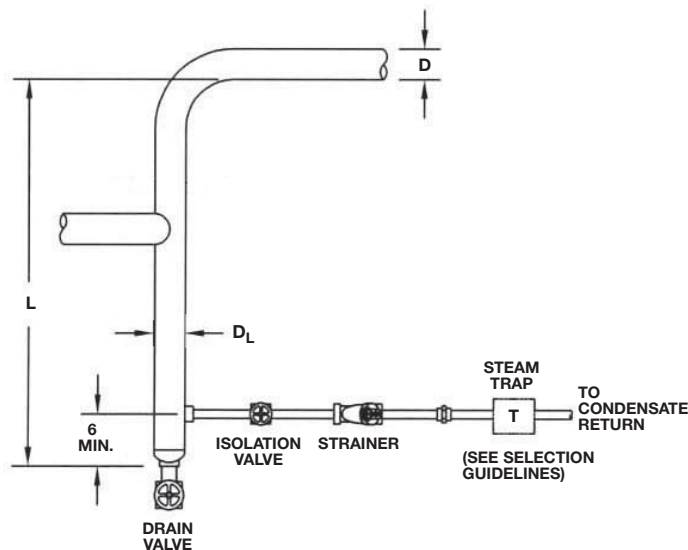

DRIP LEG AT ABRUPT CHANGES IN DIRECTION OR ELEVATION

STEAM TRAP APPLICATIONS

PROCESS STEAM TRAP – GRAVITY DRAINAGE OF HEAT TRANSFER EQUIPMENT

PURPOSE: For removing condensate from below steam heat transfer equipment to ensure optimum heating under various load conditions.

OPERATION: Steam used to heat product such as water in a heat exchanger condenses to liquid after passing through the heat exchanger and releasing its heating energy. To ensure optimum heating, this condensate is removed through an adequately sized drip leg and steam trap properly selected for the application and installed below the equipment. A Float and Thermostatic (F&T) steam trap is often an appropriate choice due to its modulating discharge and air venting capability.

INSTALLATION GUIDELINES: (see Figure 6)

- Selection and sizing of the process steam trap is critical to proper operation. A safety load factor (SLF) is applied to accommodate load variations and surges, as well as high start-up requirements. Consult appropriate sections of this catalog or the factory for guidelines regarding proper process steam trap selection and sizing.
- The collecting leg to the process trap should be no smaller than the designed condensate outlet of the heat transfer equipment. Note that some steam trap technologies such as thermostatic require extended distance between the heat exchanger and steam trap to allow for back-up of subcooled condensate.
- The process trap should be located at least 2.3 feet (28") below the condensate outlet of the heat exchanger to provide a minimum of 1 PSI head pressure.
- The drip leg and steam trap prior to the regulating valve protect the valve from condensate, as well as ensure the best quality steam for heat transfer. Note the take-off from the top of the steam main to avoid condensate that would collect on the bottom of the main piping.
- The vacuum breaker and auxiliary air vent located at the top of the heat exchanger vessel promotes proper drainage and optimum heat transfer. The vacuum breaker allows system equalization with atmospheric air to allow gravity condensate drainage when vacuum is formed from condensing steam. The air vent improves heat-up times and overall heat transfer by expelling accumulated air on start-up.
- Consider low-cracking pressure (1/4 PSI opening pressure) check valves after steam traps when discharging into condensate return lines. Check valves eliminate the possibility of condensate backing up through the steam trap into the system.
- An isolation valve and strainer should be installed before any steam trap. The isolation valve simplifies maintenance of the trap and the strainer protects the trap from any dirt, debris or scale in the line.

Figure 6:

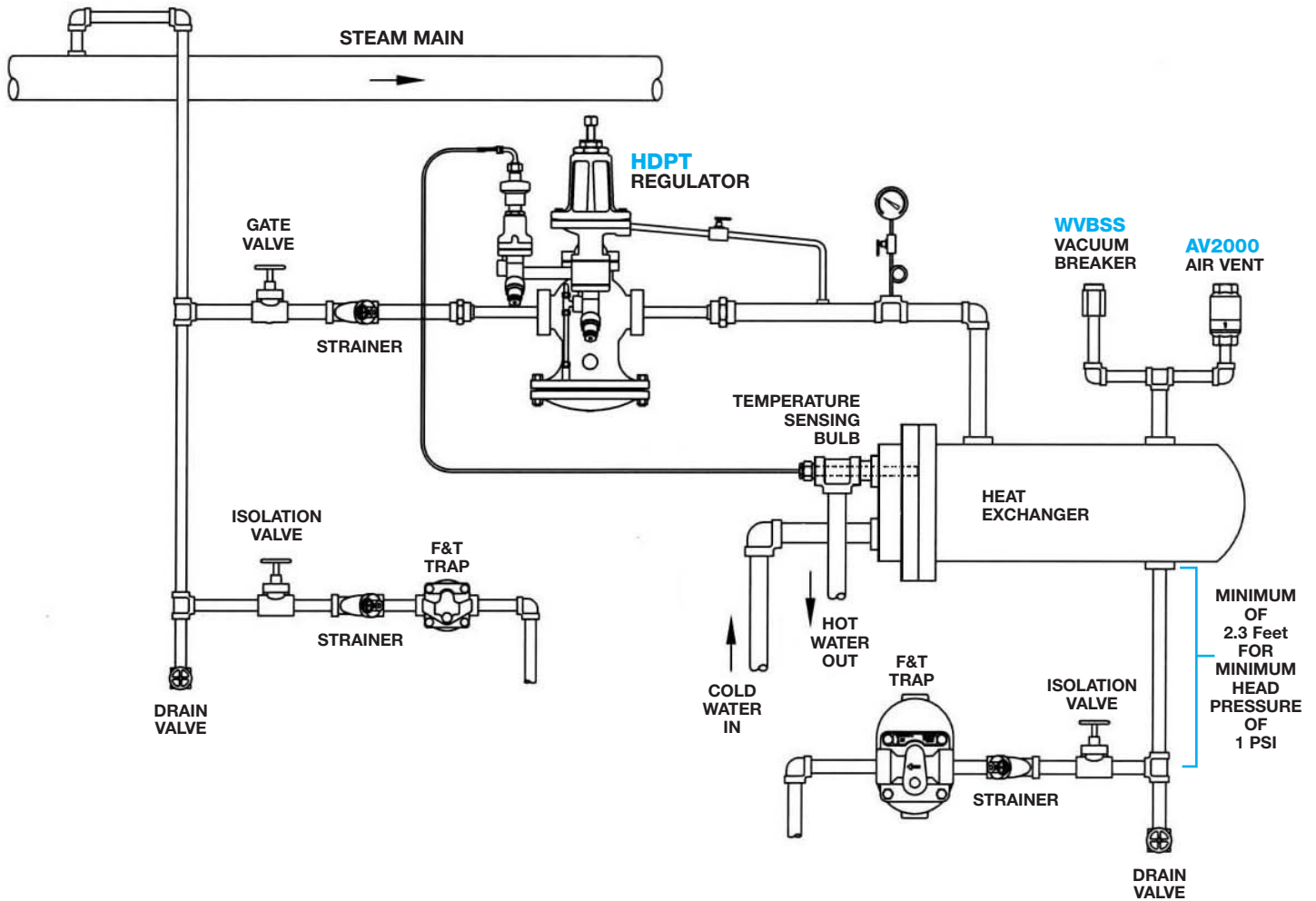

SHELL AND TUBE HEAT EXCHANGER

STEAM TRAP APPLICATIONS

PROCESS STEAM TRAP – SYPHON DRAINAGE OF HEAT TRANSFER EQUIPMENT

PURPOSE: For removing condensate from steam heat transfer equipment when the steam trap is to be installed *above* the point where condensate will collect.

OPERATION: When steam is used to heat liquid in a tank with a submerged coil or a rotary drum dryer, gravity drainage to the steam trap is not possible. For these applications, it may be necessary to install the steam trap above the drain point of the equipment by creating a syphon lift to allow for proper condensate drainage.

INSTALLATION GUIDELINES: (see Figure 7)

- There are two critical requirements to ensure proper operation of syphon lift process drainage systems: A water seal lift fitting and a steam trap with a function to prevent steam lock (often referred to as Steam Lock Release or SLR).
- The lift fitting on a submerged coil provides a water seal to stop steam from pushing past the condensate and reaching the steam trap, preventing a vapor-lock condition of the trap.
- Steam Lock Release (SLR) is provided on the steam trap to ensure the syphon lift remains continuous by preventing steam from becoming trapped – or locked – between the cavity of the steam trap and incoming condensate. The SLR function allows any small portion of trapped steam to be automatically removed from the system, allowing continuous drainage.
- Consider low-cracking pressure (1/4 PSI opening pressure) check valves after steam traps when discharging into condensate return lines. Check valves eliminate the possibility of condensate backing up through the steam trap into the system.
- An isolation valve and strainer should be installed before any steam trap. The isolation valve simplifies maintenance of the trap and the strainer protects the trap from any dirt, debris or scale in the line.

PROCESS STEAM TRAP – SYPHON DRAINAGE OF HEAT TRANSFER EQUIPMENT

Figure 7:

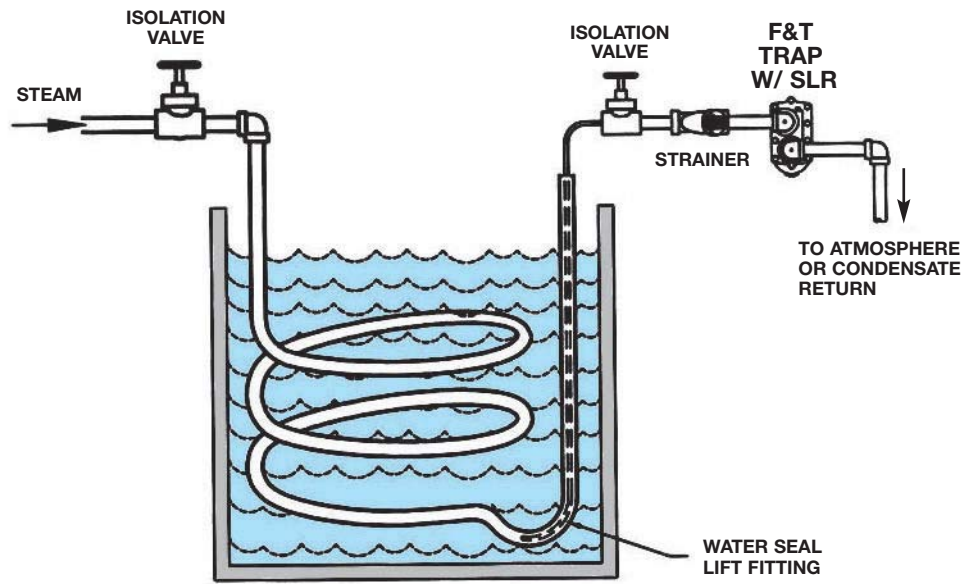

SUBMERGED COIL FOR HEATING LIQUID

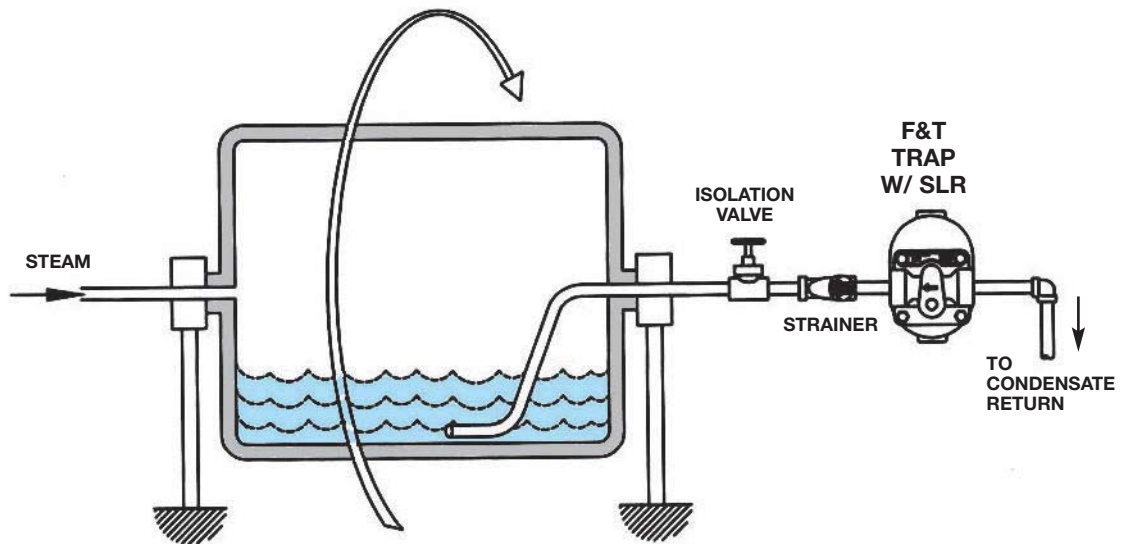

ROTARY DRUM DRYER

REGULATING VALVE APPLICATIONS

GENERAL REGULATOR APPLICATION & INSTALLATION NOTES

Regulator Application & Installation Notes

The following are considerations for all steam regulator installations, as system operation is dependent upon proper design, installation, start-up and maintenance procedures:

- Inlet & Outlet Pipe Sizing**

Improperly sized piping can contribute to erratic control and excessive noise in a steam system. Make certain inlet and outlet piping to the regulator is adequately sized for the flow, velocity and pressure requirements.

RULE OF THUMB:

Inlet piping is typically 1-2 sizes larger and outlet piping 2-3 sizes larger than the connection ports of a properly sized regulator.

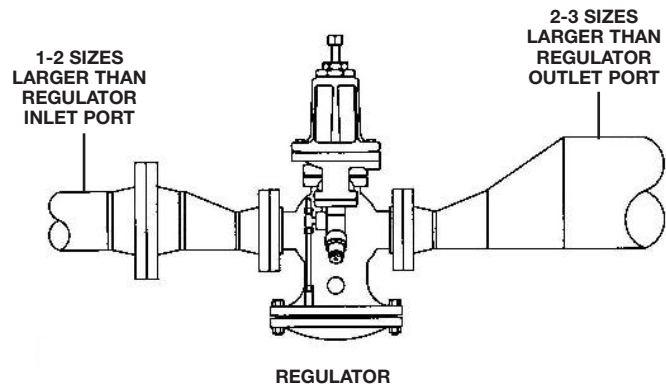

- Straight Run of Pipe Before and After the Valve**

Pipe fittings, bends and other accessories contribute to fluid turbulence in a system which can result in erratic control. To limit this and ensure optimum system operation, follow recommended guidelines for minimum straight run lengths of pipe before and after a regulator.

Note: Any isolation valves or pipeline accessories should be full-ported.

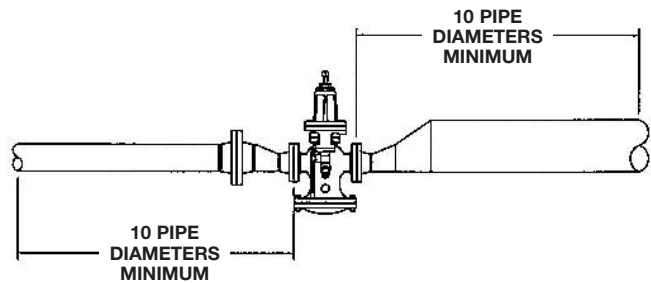

- Reducer Selection**

Concentric pipe reducers should be avoided on the inlet side of regulators as they can allow entrained condensate to collect, potentially leading to damaging and dangerous waterhammer. Therefore, when reducers are required in the steam piping to accommodate properly sized valves and pipes, use eccentric reducers on regulator inlets and concentric or eccentric reducers on regulator outlets.

CONCENTRIC REDUCER

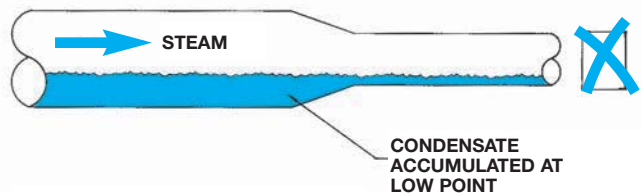

ECCENTRIC REDUCER

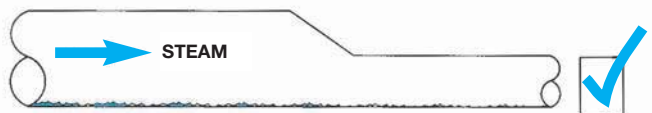

GENERAL REGULATOR APPLICATION & INSTALLATION NOTES

- **Strainers with Blowdown Valves**

Regardless of any filters provided on a regulator, a strainer with blowdown valve is recommended before (upstream of) all regulator installations. Pipeline debris and scale can damage internal valve components, potentially leading to poor operation and/or failure.

Note: Consider strainer orientation to avoid collection of condensate (see diagram).

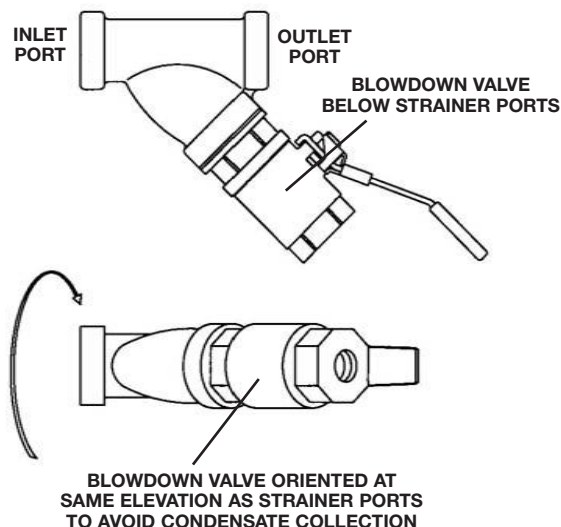

- **Drip Legs & Steam Traps**

To prevent condensate accumulated during shutdown from possibly damaging the regulator or piping at start-up, an adequately sized drip leg with steam trap should be installed prior to all regulators. This will also help protect the regulator during normal operation.

Note: Separators may be necessary when boiler carryover or “wet” steam is a concern.

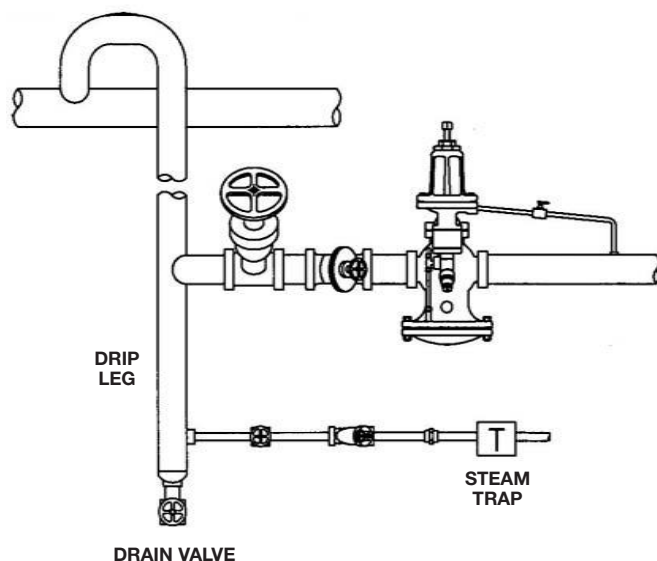

- **Proper Start-up & Maintenance Procedures**

It is important to follow good start-up practices to avoid operational complications and potential system damage. Starting a steam system too quickly or using an improper sequence may lead to a potentially hazardous working environment. Lack of system maintenance over time can also contribute to this situation.

It is imperative to develop proper start-up and maintenance procedures and train personnel on the importance of following them at all times.

Consult equipment manufacturers for specific guidelines, if necessary.



SINGLE STAGE PRESSURE REDUCING STATION USING SPRING-LOADED PILOT

PURPOSE: For reducing system inlet pressure to a constant outlet pressure.

OPERATION: The pressure reducing valve (PRV) can be easily adjusted to set the desired outlet pressure and modulates to maintain that pressure setting. The PRV requires no external power source.

INSTALLATION GUIDELINES: (see Figure 8)

- This example depicts a pilot-operated steam PRV, whereby an external sensing line is required to sense downstream pressure. The end of the sensing line is placed away from the turbulent flow of the valve outlet. This helps to improve accuracy of the set pressure. Set pressure is adjusted by turning a screw on the pilot to increase or decrease compression on a balancing spring.
- For optimum operation and service life, maintain recommended minimum piping straight runs before and after the PRV. Inlet pipe diameters are typically 1-2 sizes larger and outlet pipe diameters 2-3 sizes larger than the end connections of an appropriately sized PRV. The purpose of increasing the pipe size downstream of the regulator is to keep the steam velocity constant on both sides of the regulator.
- The pressure sensing line should slope downwards, away from the regulator, to prevent condensate from entering the pilot.
- Eccentric reducers are used on valve inlets to prevent accumulation of pipeline moisture which could become entrained with high-velocity steam, possibly resulting in dangerous waterhammer.
- While the separator shown upstream is appropriate for protection of the PRV, it is not always required as a properly sized drip leg with steam trap may be sufficient. It is recommended for systems where steam is known to be “wet” and the entrained moisture could affect valve performance and/or result in component damage.
- Consider installing a properly sized bypass line with globe valve to provide continuous operation should regulator maintenance be required.
- Consider low-cracking pressure (1/4 PSI opening pressure) check valves after steam traps when discharging into condensate return lines. Check valves eliminate the possibility of condensate backing up through the steam trap into the system.
- A safety relief valve (SRV) is appropriate where applicable codes dictate their requirement, or anywhere protection of downstream piping and equipment from over-pressurization is desired. The SRV needs to handle the complete volume of steam from the regulator and bypass loop. Consult the factory for appropriate SRV sizing guidelines.

SINGLE STAGE PRESSURE REDUCING STATION USING SPRING-LOADED PILOT

Figure 8:

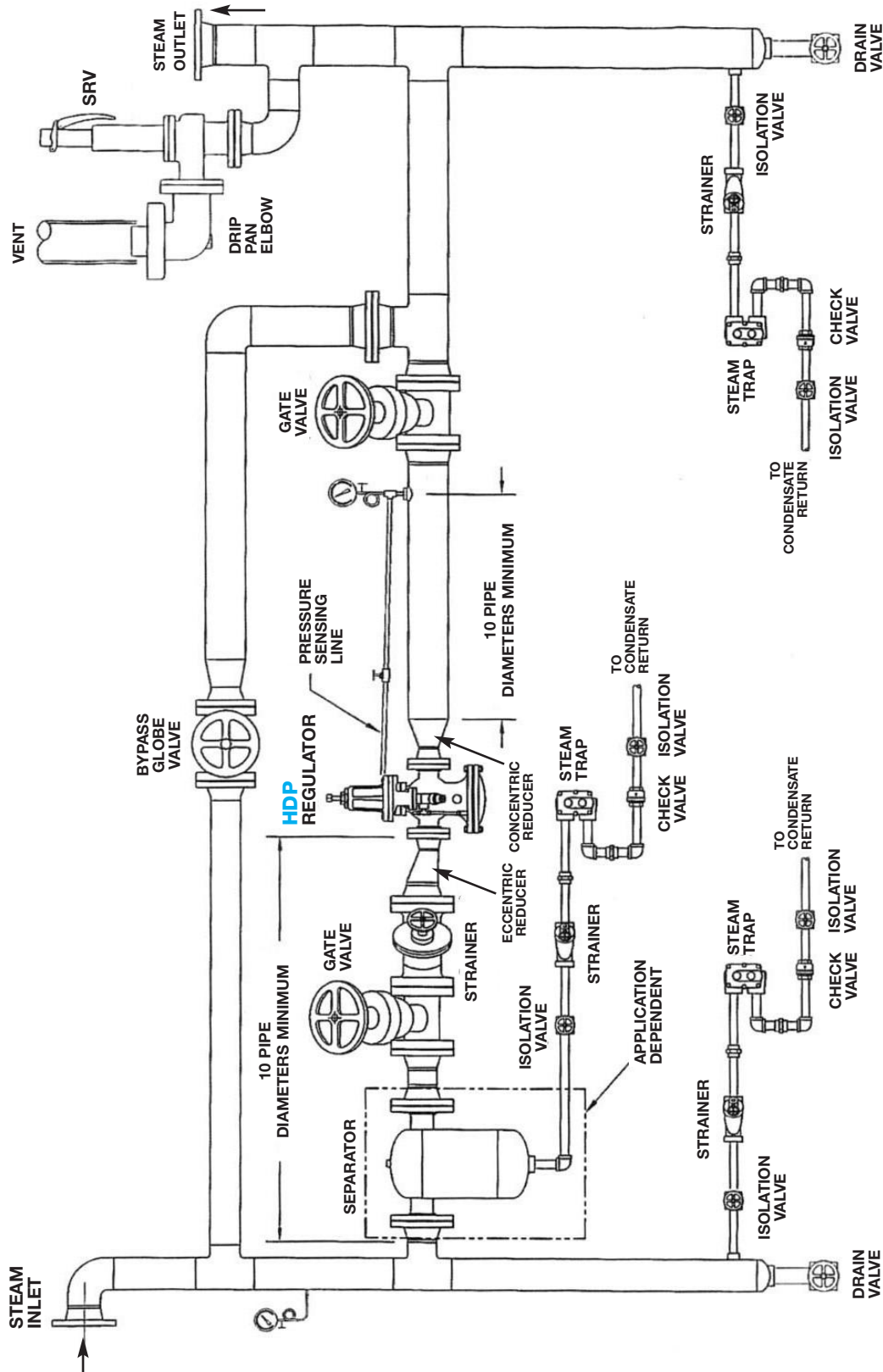

SINGLE STAGE PRESSURE REDUCING STATION USING SPRING-LOADED PILOT
(HD REGULATOR APPLICATIONS)

REGULATING VALVE APPLICATIONS

PRESSURE REDUCING STATION with AIR-LOADED PILOT for REMOTE INSTALLATIONS

PURPOSE:

For reducing system inlet pressure to a constant outlet pressure when valve is located in a remote location and/or using air pressure for control is desired.

OPERATION:

This combination of HD regulating valve and A-pilot (HDA) allows air to be used to control outlet pressure in lieu of the spring of a standard P-pilot. Using air allows for simple adjustment of control pressure when valve is installed in a remote and/or difficult to access location.

INSTALLATION GUIDELINES: (see Figure 9)

- The desired set outlet pressure will determine the specific A-Pilot required as well as the air supply pressure to attain the set pressure. Consult the appropriate section of this catalog or the factory for selection guidelines.
- For optimum operation and service life, maintain recommended minimum piping straight runs before and after the PRV. Inlet pipe diameters are typically 1-2 sizes larger and outlet pipe diameters 2-3 sizes larger than the end connections of an appropriately sized PRV. The purpose of increasing the pipe size downstream of the regulator is to keep the steam velocity constant on both sides of the regulator.
- The pressure sensing line should slope downwards, away from the regulator, to prevent condensate from entering the pilot.
- Eccentric reducers are used on valve inlets to prevent accumulation of pipeline moisture which could become entrained with high-velocity steam, possibly resulting in dangerous waterhammer.
- While the separator shown upstream is appropriate for protection of the PRV, it is not always required, as a properly sized drip leg with steam trap may be sufficient. It is recommended for systems where steam is known to be “wet” and the entrained moisture could affect valve performance and/or result in component damage.
- Consider installing a properly sized bypass line with globe valve to provide continuous operation should regulator maintenance be required.
- Consider low-cracking pressure (1/4 PSI opening pressure) check valves after steam traps when discharging into condensate return lines. Check valves eliminate the possibility of condensate backing up through the steam trap into the system.
- A safety relief valve (SRV) is appropriate where applicable codes dictate their requirement, or anywhere protection of downstream piping and equipment from over-pressurization is desired. The SRV needs to handle the complete volume of steam from the regulator and bypass loop. Consult the factory for appropriate SRV sizing guidelines.

PRESSURE REDUCING STATION with AIR-LOADED PILOT for REMOTE INSTALLATIONS

Figure 9:

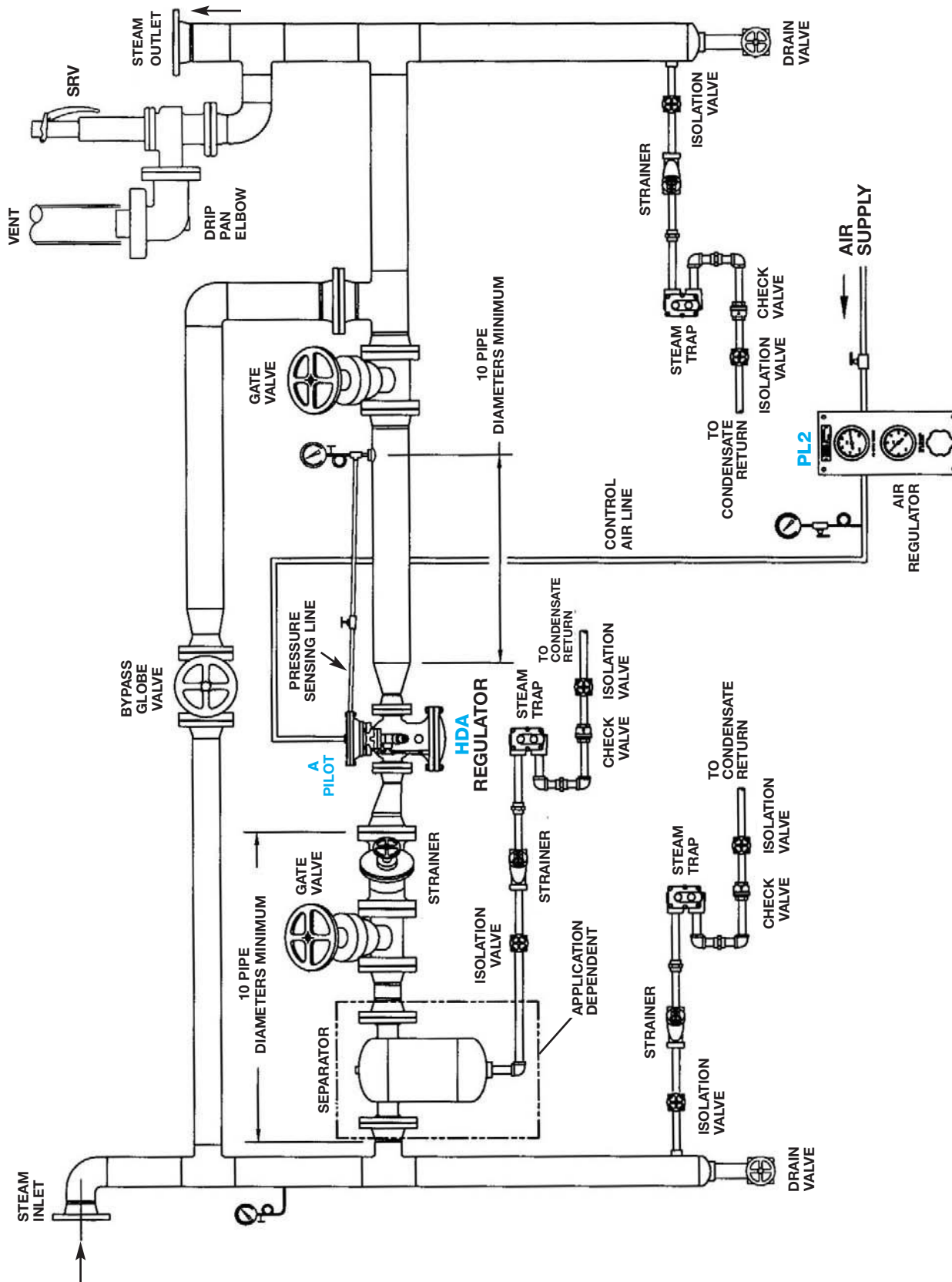

PRESSURE REDUCING STATION with AIR-LOADED PILOT for REMOTE INSTALLATIONS
(HD REGULATOR APPLICATIONS)

REGULATING VALVE APPLICATIONS

TWO-STAGE (SERIES) PRESSURE REDUCING STATION

PURPOSE: For reducing system inlet pressure to a constant outlet pressure when the pressure drop exceeds the recommended operation of a single-stage pressure regulating valve (PRV).

OPERATION: The 1st stage PRV reduces inlet pressure to an intermediate pressure. The 2nd stage PRV then reduces pressure to the final outlet pressure. Individual valve setting and operation is the same as for single-stage applications.

INSTALLATION GUIDELINES: (see Figure 10)

- This example depicts a two-stage (series) pilot-operated steam PRV pressure reducing station using HDP regulators. An external sensing line is required to sense downstream pressure from each regulator. The end of each sensing line is placed away from the turbulent flow at the valve outlet. This helps to improve accuracy of the set pressures. Set pressure for each PRV is adjusted by turning a screw on the pilot to increase or decrease compression on a balancing spring.
- For optimum operation and service life, maintain recommended minimum piping straight runs before and after the PRV. Inlet pipe diameters are typically 1-2 sizes larger and outlet pipe diameters 2-3 sizes larger than the end connections of an appropriately sized PRV. The purpose of increasing the pipe size downstream of the regulator is to keep the steam velocity constant on both sides of the regulator.
- Each pressure sensing line should slope downwards, away from the regulator, to prevent condensate from entering the pilot.
- Eccentric reducers are used on valve inlets to prevent accumulation of pipeline moisture which could become entrained with high-velocity steam, possibly resulting in dangerous waterhammer.
- While the separator shown upstream is appropriate for protection of the PRV, it is not always required, as a properly sized drip leg with steam trap may be sufficient. It is recommended for systems where steam is known to be “wet” and the entrained moisture could affect valve performance and/or result in component damage.
- Consider installing a properly sized bypass line with globe valve on each stage, to provide continuous operation should regulator maintenance be required.
- Consider low-cracking pressure (1/4 PSI opening pressure) check valves after steam traps when discharging into condensate return lines. Check valves eliminate the possibility of condensate backing up through the steam trap into the system.
- A safety relief valve (SRV) is appropriate where applicable codes dictate their requirement, or anywhere protection of downstream piping and equipment from over-pressurization is desired. The SRV needs to handle the complete volume of steam from the regulator and bypass loop. Consult the factory for appropriate SRV sizing guidelines.

Figure 10:

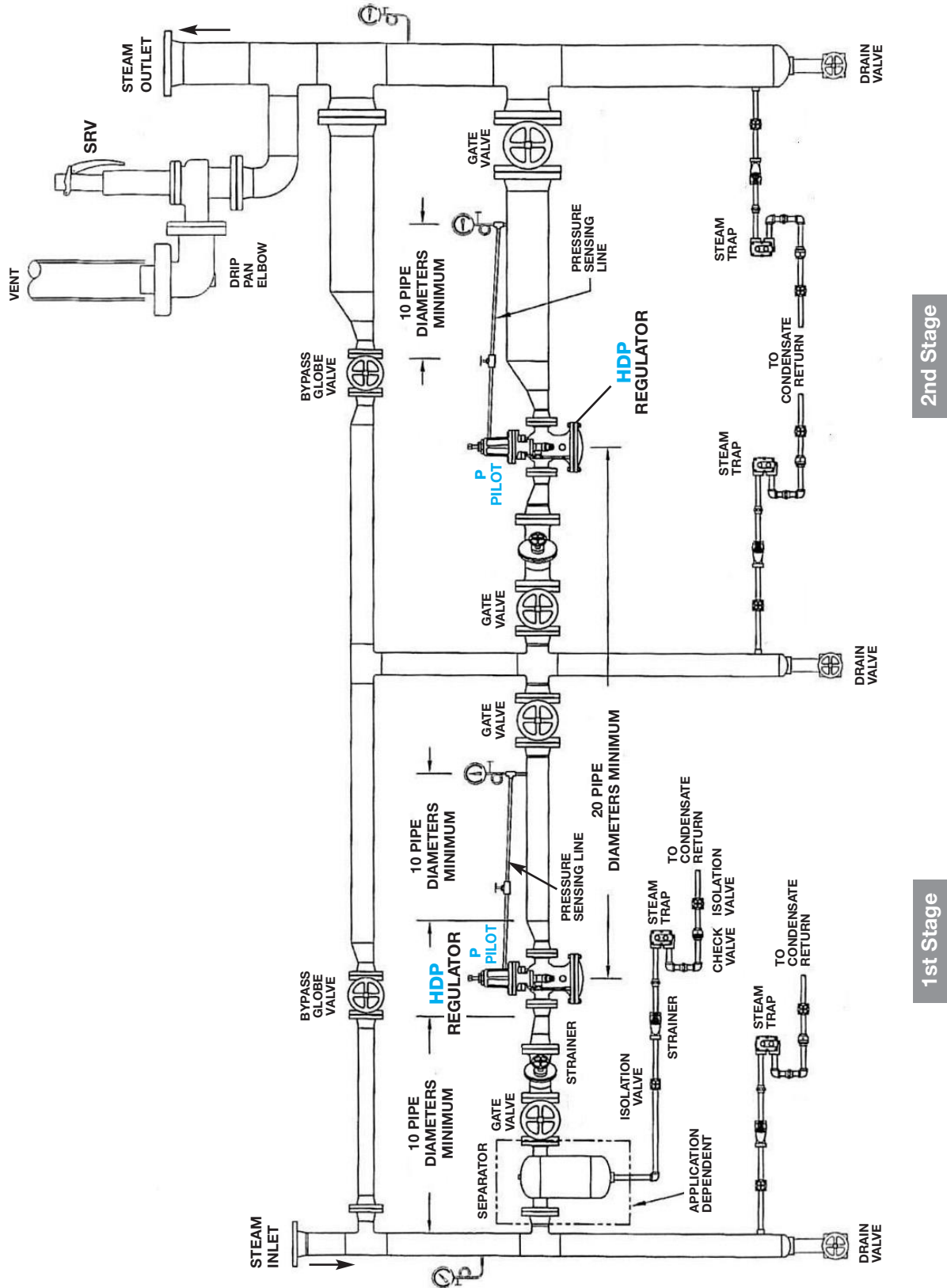

TWO-STAGE (SERIES) PRESSURE REDUCING STATION (HD REGULATOR APPLICATIONS)

2nd Stage

1st Stage

PARALLEL PRESSURE REDUCING STATION

PURPOSE: For reducing system inlet pressure to a constant outlet pressure when steam flow rates vary widely.

OPERATION: Typically referred to as 1/3 - 2/3 system, one valve may be sized for 1/3 of the total load demand and the other for 2/3. When full load is required, both valves will be open and regulating. The primary valve is set at a pressure 2 PSI higher than the secondary valve to allow the secondary valve – set at the lower pressure – to modulate closed when flow demand is reduced and outlet pressure begins to rise. The primary valve may be selected as either the larger or smaller PRV, based on expected load demands.

INSTALLATION GUIDELINES (see Figure 11)

- This example depicts a parallel pilot-operated steam PRV pressure reducing station using HDP regulators. An external sensing line is required to sense downstream pressure from each regulator. The end of each sensing line is placed away from the turbulent flow at the valve outlet. This helps to improve accuracy of the set pressures. Set pressure for each PRV is adjusted by turning a screw on the pilot to increase or decrease compression on a balancing spring.
- Proper setting of the valves is key to proper operation. The chosen primary valve should be set at a pressure approximately 2 PSI higher than that of the secondary valve.
- For optimum operation and service life, maintain recommended minimum piping straight runs before and after the PRV. Inlet pipe diameters are typically 1-2 sizes larger and outlet pipe diameters 2-3 sizes larger than the end connections of an appropriately sized PRV. The purpose of increasing the pipe size downstream of the regulator is to keep the steam velocity constant on both sides of the regulator.
- Each pressure sensing line should slope downwards, away from the regulator, to prevent condensate from entering the pilot.
- Eccentric reducers are used on valve inlets to prevent accumulation of pipeline moisture which could become entrained with high-velocity steam, possibly resulting in dangerous waterhammer.
- While the separator shown upstream is appropriate for protection of the PRV, it is not always required, as a properly sized drip leg with steam trap may be sufficient. It is recommended for systems where steam is known to be “wet” and the entrained moisture could affect valve performance and/or result in component damage.
- Consider installing a properly sized bypass line with globe valve to provide continuous operation should regulator maintenance be required.
- Consider low-cracking pressure (1/4 PSI opening pressure) check valves after steam traps when discharging into condensate return lines. Check valves eliminate the possibility of condensate backing up through the steam trap into the system.
- A safety relief valve (SRV) is appropriate where applicable codes dictate their requirement, or anywhere protection of downstream piping and equipment from over-pressurization is desired. The SRV needs to handle the complete volume of steam from the regulator and bypass loop. Consult the factory for appropriate SRV sizing guidelines.

Figure 11:

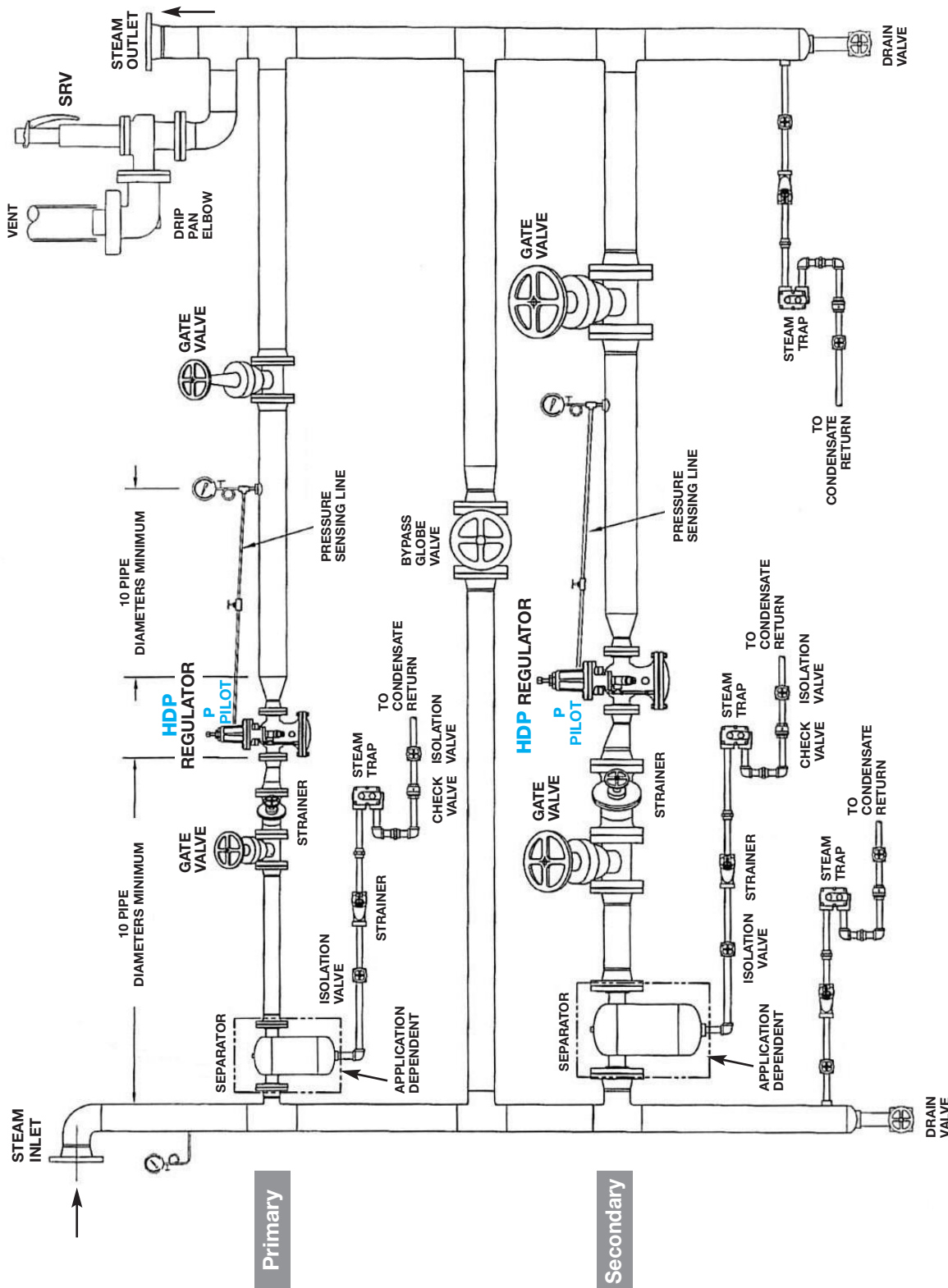

PARALLEL PRESSURE REDUCING STATION
(HD REGULATOR APPLICATIONS)

REGULATING VALVE APPLICATIONS

TWO-STAGE PARALLEL PRESSURE REDUCING STATION

PURPOSE: For reducing system inlet pressure to a constant outlet pressure when both flow conditions vary widely and a high pressure drop (i.e. higher than the recommended range of a single stage regulator) is required.

OPERATION: This system is a combination of Two-Stage (Series) and Parallel pressure reducing stations and operates based on the individual principles of each system. This allows for accurate control of outlet pressure when both high pressure and high flow turndowns are required.

INSTALLATION GUIDELINES: (see Figure 12)

- This example depicts a two-stage parallel pilot-operated steam PRV pressure reducing station using HDP regulators. An external sensing line is required to sense downstream pressure from each regulator. The end of each sensing line is placed away from the turbulent flow at the valve outlet. This helps to improve accuracy of the set pressures. Set pressure for each PRV is adjusted by turning a screw on the pilot to increase or decrease compression on a balancing spring.
- Proper setting of the valves is key to proper operation. The chosen 1st stage primary valve should be set at a pressure approximately 2 PSI higher than that of the 1st stage secondary valve.
- For optimum operation and service life, maintain recommended minimum piping straight runs before and after the PRV. Inlet pipe diameters are typically 1-2 sizes larger and outlet pipe diameters 2-3 sizes larger than the end connections of an appropriately sized PRV. The purpose of increasing the pipe size downstream of the regulator is to keep the steam velocity constant on both sides of the regulator.
- Each pressure sensing line should slope downwards, away from the regulator, to prevent condensate from entering the pilot.
- Eccentric reducers are used on valve inlets to prevent accumulation of pipeline moisture which could become entrained with high-velocity steam, possibly resulting in dangerous waterhammer.
- While the separator shown upstream is appropriate for protection of the PRV, it is not always required, as a properly sized drip leg with steam trap may be sufficient. It is recommended for systems where steam is known to be “wet” and the entrained moisture could affect valve performance and/or result in component damage.
- Consider installing a properly sized bypass line with globe valve on each stage, to provide continuous operation should regulator maintenance be required.
- Consider low-cracking pressure (1/4 PSI opening pressure) check valves after steam traps when discharging into condensate return lines. Check valves eliminate the possibility of condensate backing up through the steam trap into the system.
- A safety relief valve (SRV) is appropriate where applicable codes dictate their requirement, or anywhere protection of downstream piping and equipment from over-pressurization is desired. The SRV needs to handle the complete volume of steam from the regulator and bypass loops. Consult the factory for appropriate SRV sizing guidelines.

TWO-STAGE PARALLEL PRESSURE REDUCING STATION

Figure 12:

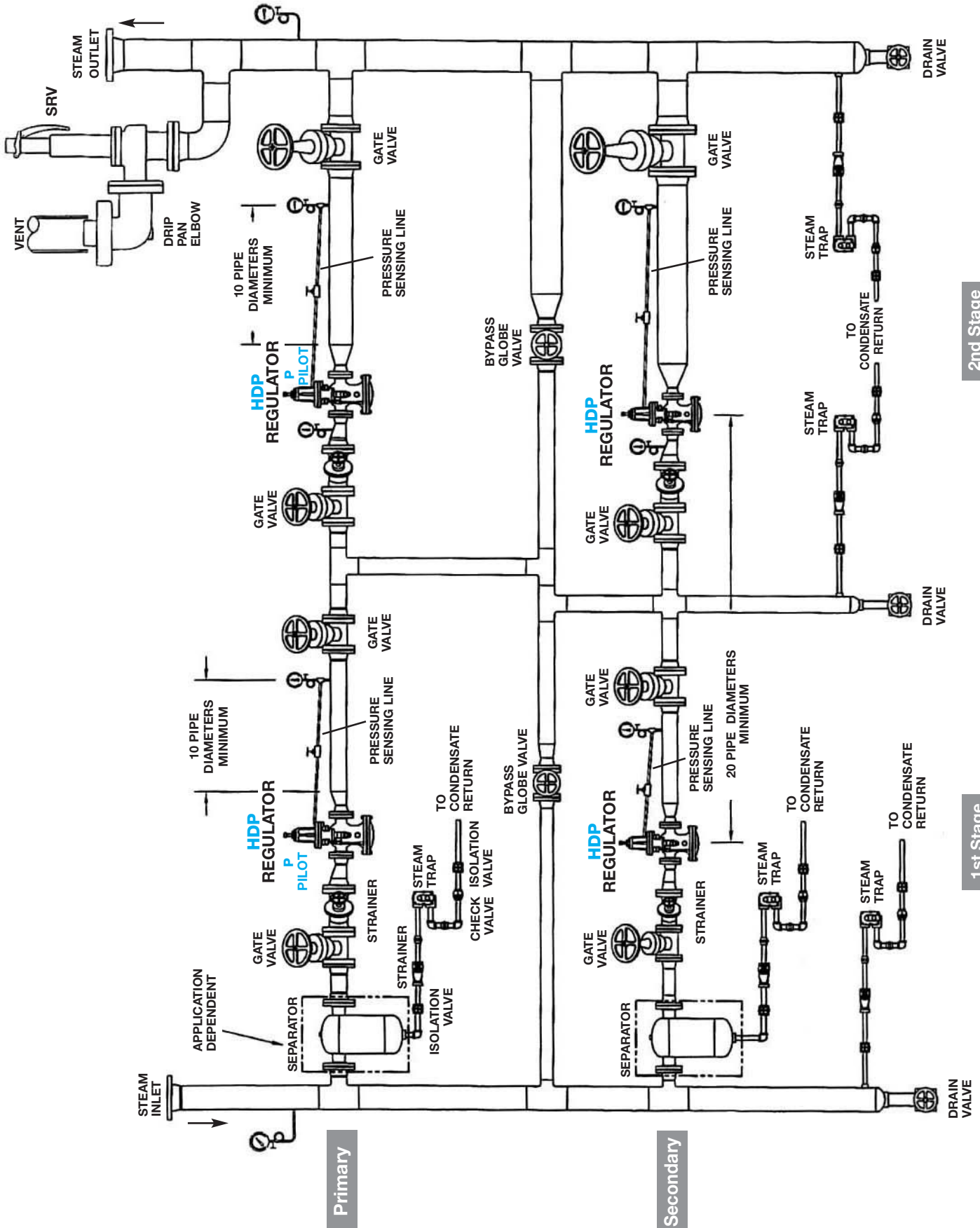

TWO-STAGE PARALLEL PRESSURE REDUCING STATION (HDP REGULATOR APPLICATIONS)

TEMPERATURE CONTROL of a HEAT EXCHANGER with PRESSURE LIMITING

PURPOSE: For accurately controlling both temperature of a product being heated in heat transfer equipment as well as limiting the pressure of the incoming steam, providing optimum heat transfer characteristics.

OPERATION: When a pilot-operated HD valve is selected, a single valve can be used for both pressure and temperature control when equipped with a P-pilot and T-pilot (HDPT). As temperature at the sensing bulb falls below set point, the valve begins to modulate open to supply steam for heating. Supply pressure to the heat exchanger is then controlled by adjusting the pressure pilot to the recommended value for optimum heat transfer and/or a limiting pressure of the heat transfer equipment. The HDPT Regulator requires no external power source.

INSTALLATION GUIDELINES: (see Figure 13)

- The temperature and pressure pilots should be set individually, starting slowly and gradually with the T-pilot.
- Care should be given to the installation of the temperature sensing bulb to ensure full immersion in the liquid. The sensing bulb should be placed as close as possible to the heat exchanger vessel to ensure accurate temperature control of the process fluid.
- For optimum operation and service life, maintain recommended minimum piping straight runs before and after the PRV. Inlet pipe diameters are typically 1-2 sizes larger and outlet pipe diameters 2-3 sizes larger than the end connections of an appropriately sized PRV. The purpose of increasing the pipe size downstream of the regulator is to keep the steam velocity constant on both sides of the regulator.
- The pressure sensing line should slope downwards, away from the regulator, to prevent condensate from entering the pilot.
- Eccentric reducers, if required, are used on valve inlets to prevent accumulation of pipeline moisture which could become entrained with high-velocity steam, possibly resulting in dangerous waterhammer.
- While the separator shown upstream is appropriate for protection of the PRV, it is not always required, as a properly sized drip leg with steam trap may be sufficient. It is recommended for systems where steam is known to be “wet” and the entrained moisture could affect valve performance and/or result in component damage.
- Consider low-cracking pressure (1/4 PSI opening pressure) check valves after steam traps when discharging into condensate return lines. Check valves eliminate the possibility of condensate backing up through the steam trap into the system.
- The vacuum breaker and auxiliary air vent located at the top of the heat exchanger vessel promotes proper drainage and optimum heat transfer. The vacuum breaker allows system equalization with atmospheric air to allow gravity condensate drainage when vacuum is formed from condensing steam. The air vent improves heat-up times and overall heat transfer by expelling accumulated air on start-up.
- A safety relief valve (SRV) is appropriate where applicable codes dictate their requirement, or anywhere protection of downstream piping and equipment from over-pressurization is desired. Consult the factory for appropriate SRV sizing guidelines.

TEMPERATURE CONTROL of a HEAT EXCHANGER with PRESSURE LIMITING

Figure 13:

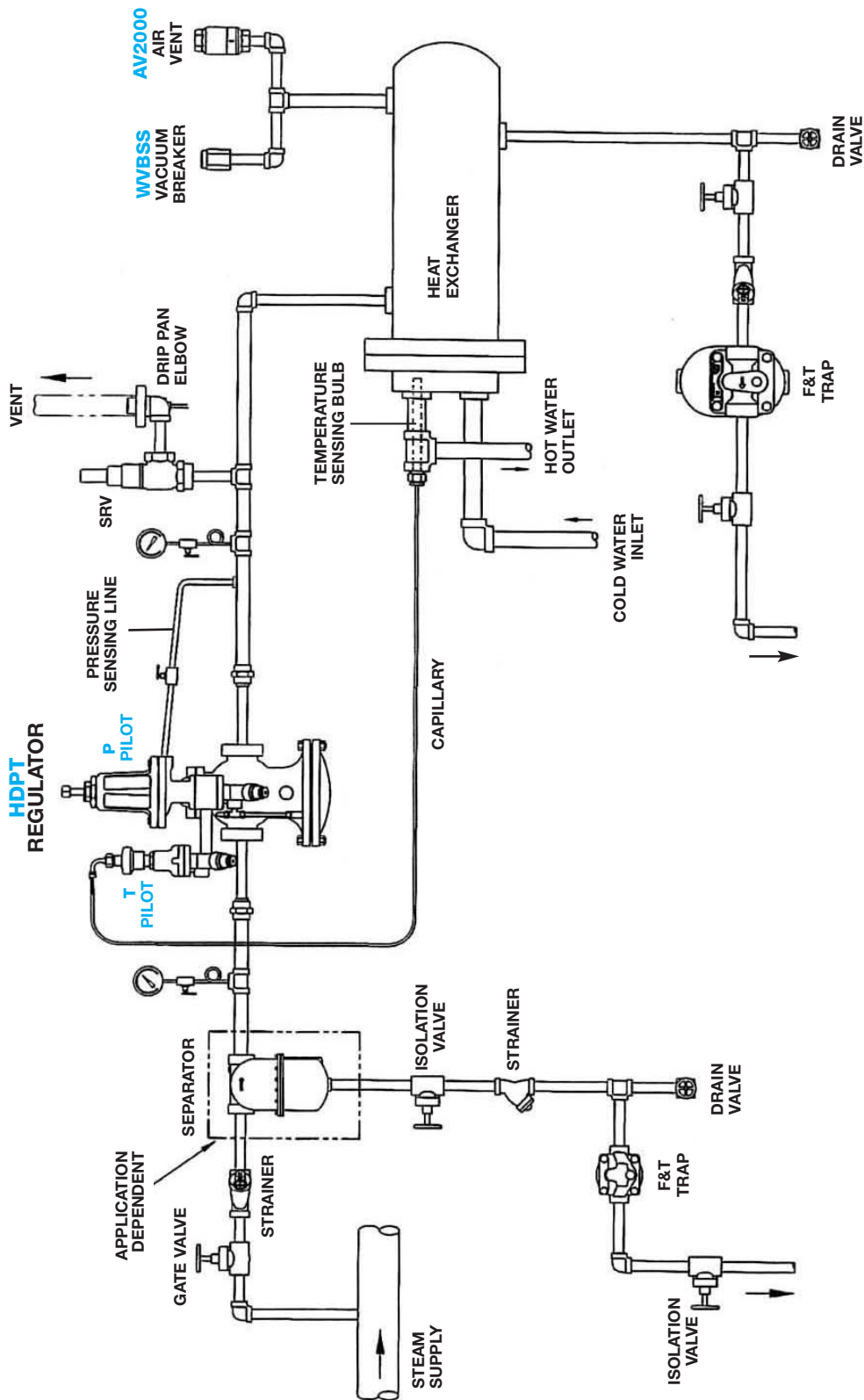

TEMPERATURE CONTROL of a HEAT EXCHANGER with PRESSURE LIMITING
(HD REGULATOR APPLICATIONS)

REGULATING VALVE APPLICATIONS

AUTOMATIC TEMPERATURE CONTROL of a BATCH PROCESS with Electrical Time Sequence Programmer (Solenoid Pilot)

PURPOSE: For accurately controlling temperature of a batch process where on-off operation is to be electronically controlled.

OPERATION: Operation is similar to that of the pressure and temperature combination pilot-operated regulator whereby the temperature (T) pilot senses the temperature inside the autoclave and appropriately modulates the flow of steam. Pressure is limited by the pressure (P) pilot. The solenoid valve (S-pilot) is electronically activated to control on-off operation of the batch process. (The HD Regulator operating with these three pilots is known as the HDPTS Regulator.)

INSTALLATION GUIDELINES: (see Figure 14)

- The temperature and pressure pilots should be set individually, starting slowly and gradually with the T-pilot.
- For optimum operation and service life, maintain recommended minimum piping straight runs before and after the PRV. Inlet pipe diameters are typically 1-2 sizes larger and outlet pipe diameters 2-3 sizes larger than the end connections of an appropriately sized PRV. The purpose of increasing the pipe size downstream of the regulator is to keep the steam velocity constant on both sides of the regulator.
- The pressure sensing line should slope downwards, away from the regulator, to prevent condensate from entering the pilot.
- Eccentric reducers, if required, are used on valve inlets to prevent accumulation of pipeline moisture which could become entrained with high-velocity steam, possibly resulting in dangerous waterhammer.
- While the separator shown upstream is appropriate for protection of the PRV, it is not always required, as a properly sized drip leg with steam trap may be sufficient. It is recommended for systems where steam is known to be “wet” and the entrained moisture could affect valve performance and/or result in component damage.
- Consider low-cracking pressure (1/4 PSI opening pressure) check valves after steam traps when discharging into condensate return lines. Check valves eliminate the possibility of condensate backing up through the steam trap into the system.
- The thermostatic air vent located at the top of the autoclave chamber promotes optimum heat transfer. The air vent improves heat-up times and overall heat transfer by expelling accumulated air on start-up.
- A safety relief valve (SRV) is appropriate where applicable codes dictate their requirement, or anywhere protection of downstream piping and equipment from over-pressurization is desired. Consult the factory for appropriate SRV sizing guidelines.

AUTOMATIC TEMPERATURE CONTROL of a BATCH PROCESS with Electrical Time Sequence Programmer (Solenoid Pilot)

Figure 14:

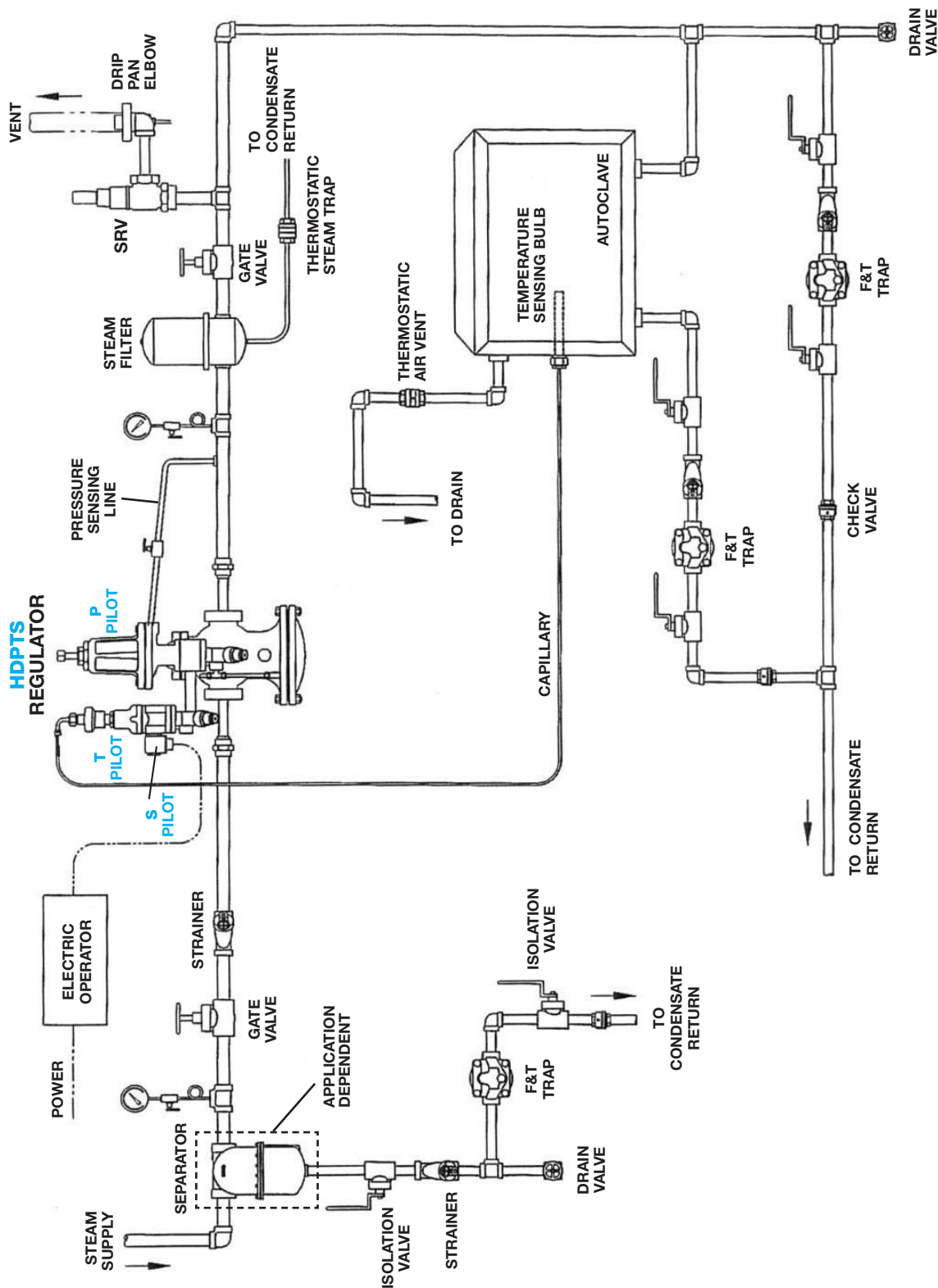

AUTOMATIC TEMPERATURE CONTROL of a BATCH PROCESS with Electrical Time Sequence Programmer (Solenoid Pilot)
(HD REGULATOR APPLICATIONS)

REGULATING VALVE APPLICATIONS

TEMPERATURE CONTROL of a SEMI-INSTANTANEOUS HEATER using a Self-Contained Temperature Regulating Valve

PURPOSE: For accurate control of the temperature of a product being heated when the benefits of a self-contained regulator are required.

OPERATION: A self-contained temperature regulating valve (TRV) such as the W91, offers response times and characteristics suitable for semi-instantaneous heating applications. The temperature sensing bulb senses the temperature of the liquid being heated and allows modulation of the valve for appropriate supply of steam.

INSTALLATION GUIDELINES: (see Figure 15)

- Care should be given to the installation of the temperature sensing bulb to ensure full immersion in the liquid. The sensing bulb should be placed as close as possible to the heater tank to ensure accurate temperature control of the process fluid.
- For optimum operation and service life, maintain recommended minimum piping straight runs before and after the PRV. Inlet pipe diameters are typically 1-2 sizes larger and outlet pipe diameters 2-3 sizes larger than the end connections of an appropriately sized PRV. The purpose of increasing the pipe size downstream of the regulator is to keep the steam velocity constant on both sides of the regulator.
- All pressure sensing lines should slope downwards, away from the regulator, to prevent condensate from entering the pilot.
- Eccentric reducers, if required, are used on valve inlets to prevent accumulation of pipeline moisture which could become entrained with high-velocity steam, possibly resulting in dangerous waterhammer.
- While the separator shown upstream is appropriate for protection of the PRV, it is not always required, as a properly sized drip leg with steam trap may be sufficient. It is recommended for systems where steam is known to be “wet” and the entrained moisture could affect valve performance and/or result in component damage.
- Consider installing a properly sized bypass line with globe valve to provide continuous operation should regulator maintenance be required.
- Consider low-cracking pressure (1/4 PSI opening pressure) check valves after steam traps when discharging into condensate return lines. Check valves eliminate the possibility of condensate backing up through the steam trap into the system.
- The vacuum breaker and auxiliary air vent located at the top of the heater tank promotes proper drainage and optimum heat transfer. The vacuum breaker allows system equalization with atmospheric air to allow gravity condensate drainage when vacuum is formed from condensing steam. The air vent improves heat-up times and overall heat transfer by expelling accumulated air on start-up.
- A safety relief valve (SRV) is appropriate where applicable codes dictate their requirement, or anywhere protection of downstream piping and equipment from over-pressurization is desired. The SRV needs to handle the complete volume of steam from the regulator and bypass loop. Consult the factory for appropriate SRV sizing guidelines.

TEMPERATURE CONTROL of a SEMI-INSTANTANEOUS HEATER using a Self-Contained Temperature Regulating Valve

Figure 15:

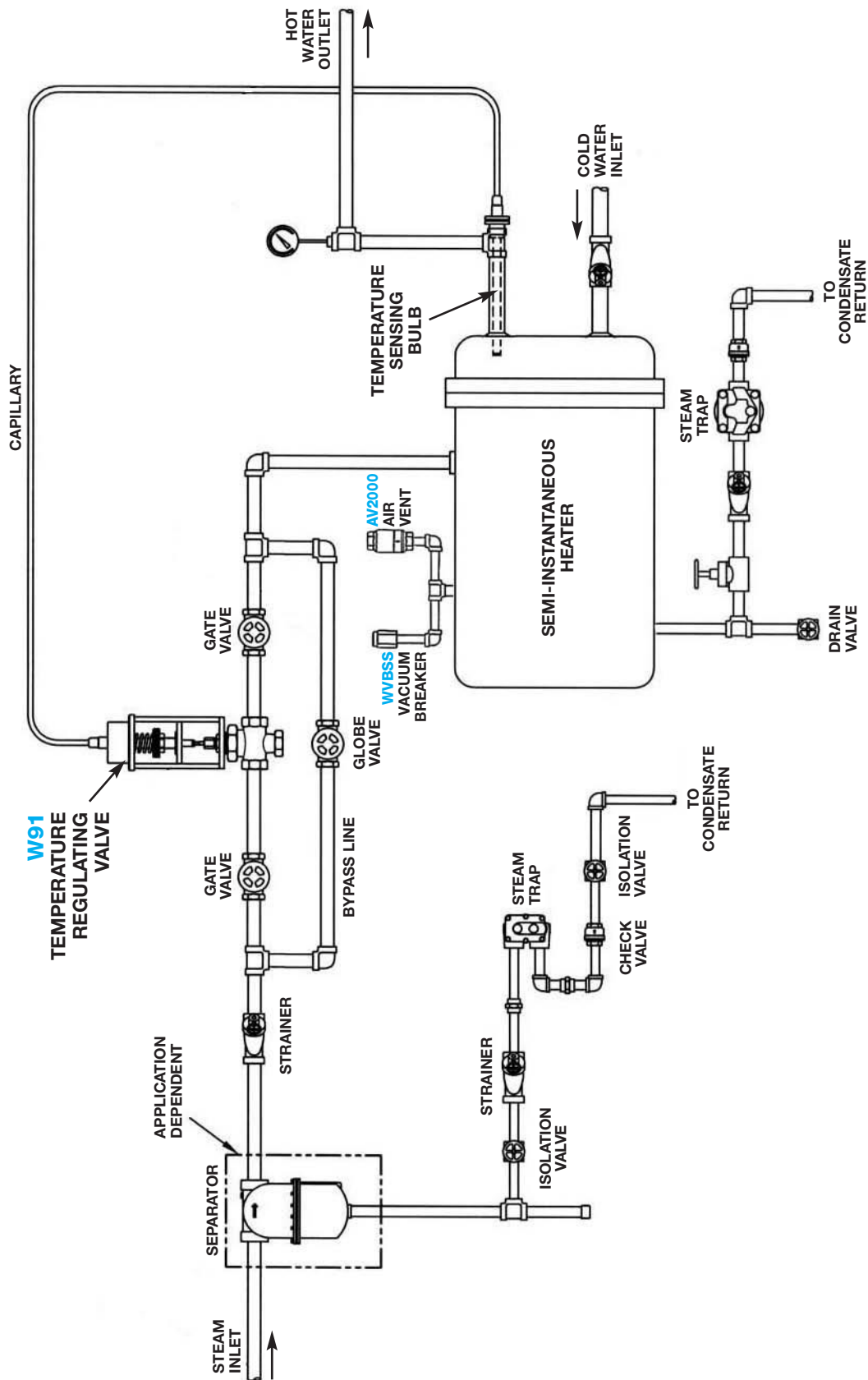

SEMI-INSTANTANEOUS HOT WATER HEATER WITH W91 TEMPERATURE REGULATOR
(TEMPERATURE REGULATOR APPLICATIONS)

PRESSURE MOTIVE PUMP (PMP) APPLICATIONS

DRAINAGE of a SINGLE SOURCE of CONDENSATE for a CLOSED LOOP SYSTEM

PURPOSE: For removing condensate from below steam heat transfer equipment when a modulating valve is used for control and stall conditions will exist.

OPERATION: The Pressure Motive Pump (PMP) is used to overcome the stall condition that exists when steam feeding a single piece of heat transfer equipment is controlled by a modulating steam valve and steam pressure falls below system back pressure as the valve closes. A steam trap is required after the

PMP

to prevent the loss of live steam when the system is under positive pressure. Operating as a closed loop provides an energy-efficient system by eliminating the need to vent flash steam.

INSTALLATION GUIDELINES: (see Figure 16)

- Proper installation and piping of the pump vent line is critical to ensure the system operates correctly. Follow guidelines or consult factory for additional information.
- Maintain proper fill head above the top of the pump to ensure proper function of the pump and system. A suitably sized reservoir or oversized piping should be installed ahead of the pump for accumulation of condensate during the pump's discharge cycle (i.e. not filling).
- The steam trap after the pump must be sized in conjunction with the pump to ensure proper function as a system. Improper sizing may result in reduced capacity leading to condensate back-up, poor heat transfer and potentially dangerous waterhammer. Consult appropriate sections of this catalog or the factory for guidelines regarding proper sizing of the pump-trap combination.
- While the separator shown upstream is appropriate for protection of the PRV, it is not always required, as a properly sized drip leg with steam trap may be sufficient. It is recommended for systems where steam is known to be "wet" and the entrained moisture could affect valve performance and/or result in component damage.
- Consider low-cracking pressure (1/4 PSI opening pressure) check valves after steam traps when discharging into condensate return lines. Check valves eliminate the possibility of condensate backing up through the steam trap into the system.
- The thermostatic air vent located above the condensate reservoir promotes optimum heat transfer. The air vent improves heat-up times and overall heat transfer by expelling accumulated air on start-up.

PRESSURE MOTIVE PUMP (PMP) APPLICATIONS

DRAINAGE of a SINGLE SOURCE of CONDENSATE for a CLOSED LOOP SYSTEM

Figure 16:

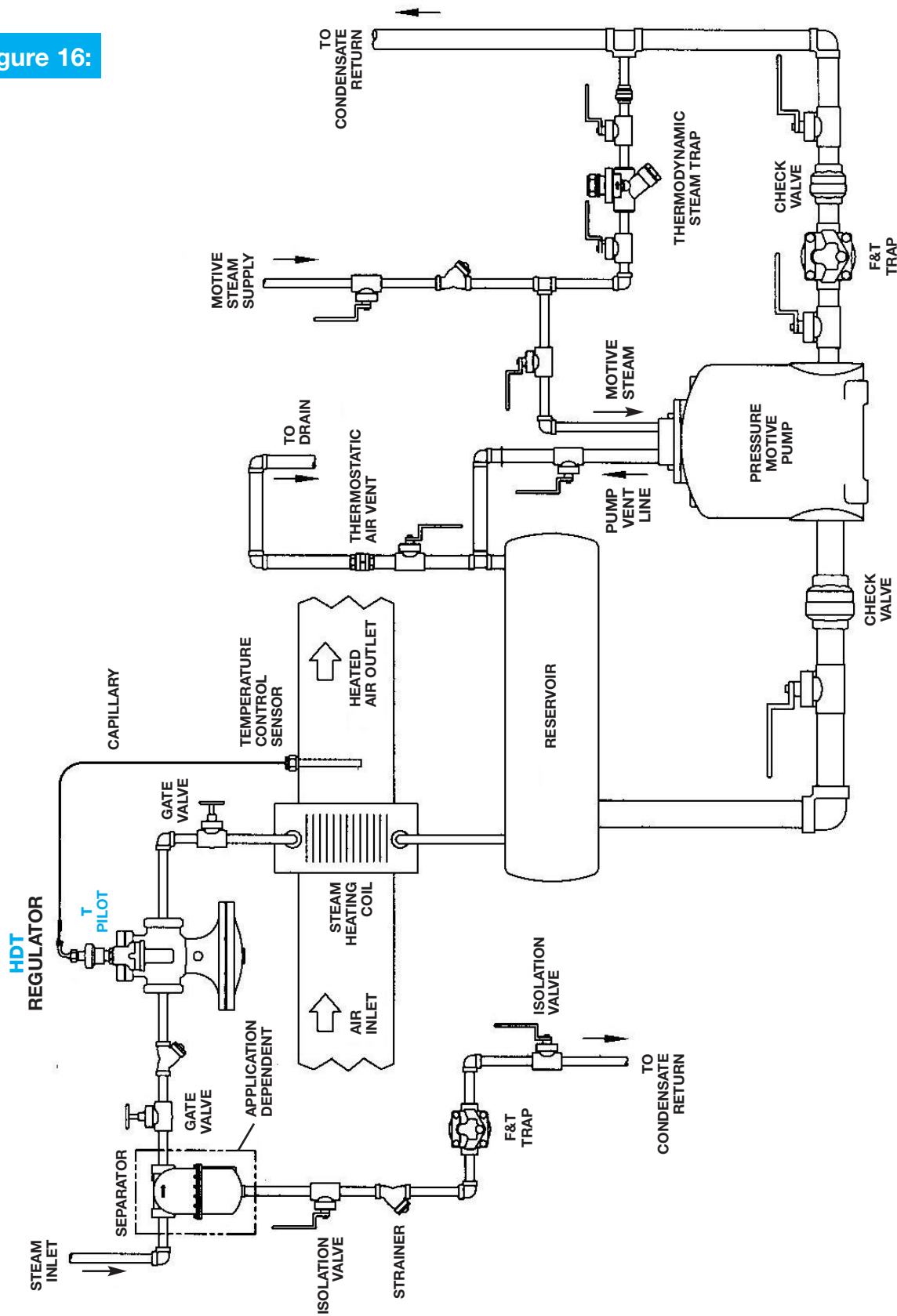

DRAINAGE of a SINGLE SOURCE of CONDENSATE for a CLOSED LOOP SYSTEM
(PMP APPLICATIONS)

PRESSURE MOTIVE PUMP (PMP) APPLICATIONS

DRAINAGE of CONDENSATE FROM BELOW GRADE for a CLOSED LOOP SYSTEM To Achieve Minimal Fill Head

PURPOSE: For drainage of condensate from below process equipment where fill head is limited due to height restrictions and the pump must be installed below grade.

OPERATION: When fill head is restricted and it is more suitable to create a pit below grade than reposition process equipment, the Pressure Motive Pump (PMP) may be modified so both condensate inlet and outlet connections are on top to limit the necessary pit size. When stall exists, condensate will accumulate between the inlet and outlet check valves and eventually drain into and fill the PMP tank. Once the PMP fills and its mechanism trips, high pressure motive steam will enter the pump tank and force condensate back out the same connection. The check valves will direct the flow of pumped condensate into the return piping.

INSTALLATION GUIDELINES: (see Figure 17)

- The positioning of the check valves and PMP fill/discharge line are the key elements which allow the system to function properly. The check valves dictate the proper direction of condensate flow for both fill and discharge cycles of the PMP. The PMP fill/discharge line should be taken off the top, as shown, so condensate only accumulates and fills the pump during stall.
- Proper installation and piping of the pump vent line is critical to ensure the system operates correctly. Follow guidelines or consult factory for additional information.
- Maintain proper fill head above the top of the pump to ensure proper function of the pump and system. A suitably sized reservoir or oversized piping should be installed ahead of the pump for accumulation of condensate during the pump's discharge cycle (i.e. not filling).
- The steam trap after the pump must be sized in conjunction with the pump to ensure proper function as a system. Improper sizing may result in reduced capacity leading to condensate back-up, poor heat transfer and potentially dangerous waterhammer. Consult appropriate sections of this catalog or the factory for guidelines regarding proper sizing of the pump-trap combination.
- Consider low-cracking pressure (1/4 PSI opening pressure) check valves after steam traps when discharging into condensate return lines. Check valves eliminate the possibility of condensate backing up through the steam trap into the system.
- The thermostatic air vent located above the condensate reservoir promotes optimum heat transfer. The air vent improves heat-up times and overall heat transfer by expelling accumulated air on start-up.

PRESSURE MOTIVE PUMP (PMP) APPLICATIONS

DRAINAGE of CONDENSATE FROM BELOW GRADE for a CLOSED LOOP SYSTEM To Achieve Minimal Fill Head

Figure 17:

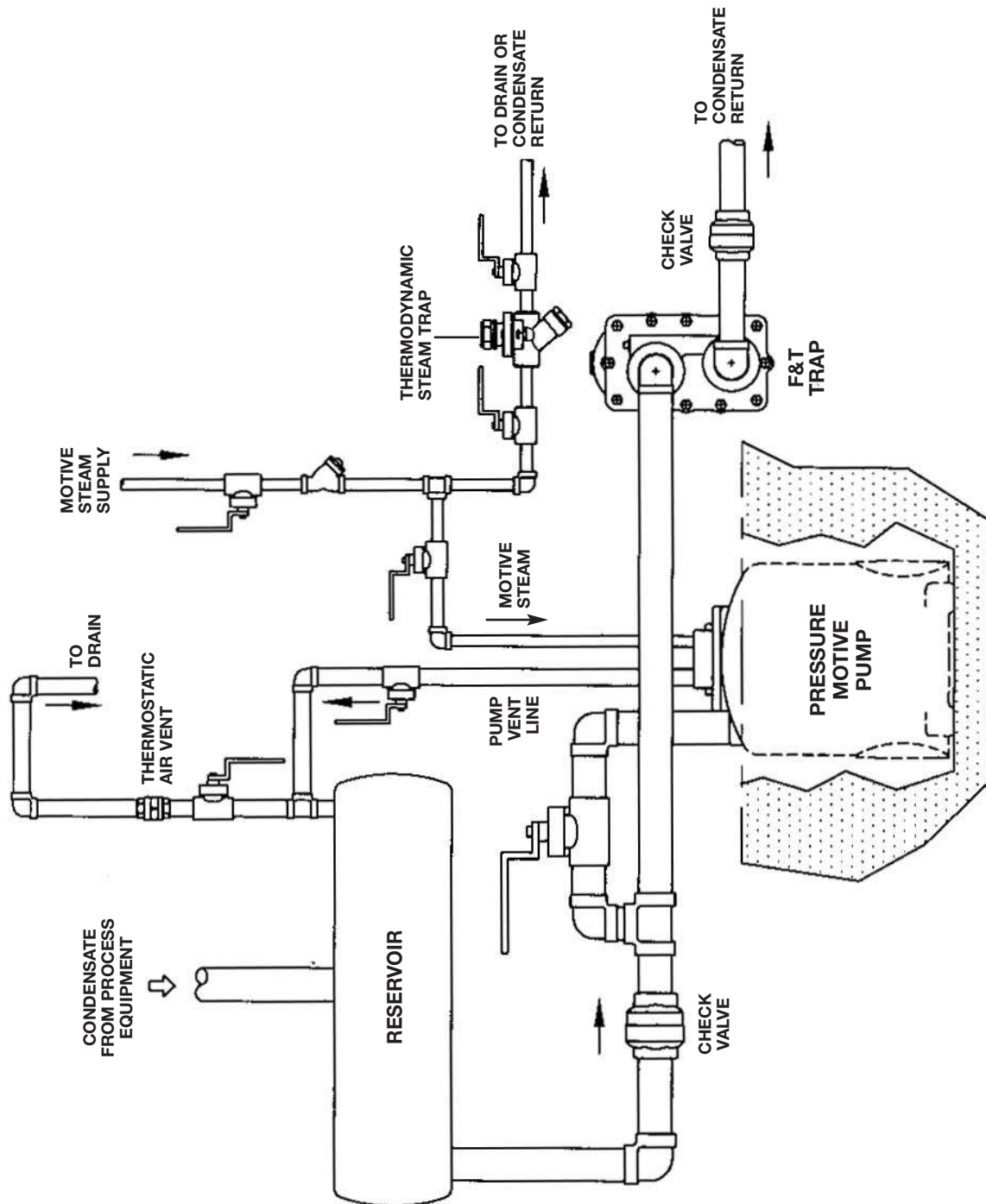

**DRAINAGE of CONDENSATE FROM BELOW GRADE for a CLOSED LOOP SYSTEM
to Achieve Minimal Fill Head
(PMP APPLICATIONS)**

FLASH STEAM RECOVERY

PURPOSE:

For recovering flash steam from multiple condensate sources and drainage of the condensate when the total system back pressure is greater than the total of the individual source pressures.

OPERATION:

Condensate at various pressures collects in a receiver (flash tank), equalizing the pressures to that of the flash tank. This allows drainage by gravity into the Pressure Motive Pump (PMP), filling the PMP until the internal mechanism reaches its upper trip point and activates the motive steam used for pumping. The flash steam generated from the high pressure condensate may be used to supplement other applications for optimum energy efficiency. The pressure in the receiver tank is maintained by a back pressure regulator and protected by a safety relief valve.

INSTALLATION GUIDELINES: (see Figure 18)

- The key element for proper system operation is the sizing of the receiver tank and receiver vent connection, which must accommodate the flash steam. Consult appropriate sections of this catalog or the factory for guidelines regarding proper sizing of the receiver tank and receiver vent connection.
- Proper installation and piping of the pump vent line is critical to ensure the system operates correctly. Follow guidelines or consult factory for additional information.
- Careful consideration should be given to sizing of the auxiliary components such as the back pressure regulator and safety relief valve.
- Maintain proper fill head above the top of the pump to ensure proper function of the pump and system. A suitably sized receiver or oversized piping should be installed ahead of the pump for accumulation of condensate during the pump's discharge cycle (i.e. not filling).
- The steam trap after the pump must be sized in conjunction with the pump to ensure proper function as a system. Improper sizing may result in reduced capacity leading to condensate back-up, poor heat transfer and potentially dangerous waterhammer. Consult appropriate sections of this catalog or the factory for guidelines regarding proper sizing of the pump-trap combination.
- While the separator shown upstream is appropriate for protection of the PRV, it is not always required, as a properly sized drip leg with steam trap may be sufficient. It is recommended for systems where steam is known to be "wet" and the entrained moisture could affect valve performance and/or result in component damage.
- Consider low-cracking pressure (1/4 PSI opening pressure) check valves after steam traps when discharging into condensate return lines. Check valves eliminate the possibility of condensate backing up through the steam trap into the system.
- A safety relief valve (SRV) is appropriate where applicable codes dictate their requirement, or anywhere protection of downstream piping and equipment from over-pressurization is desired. Consult the factory for appropriate SRV sizing guidelines.

Figure 18:

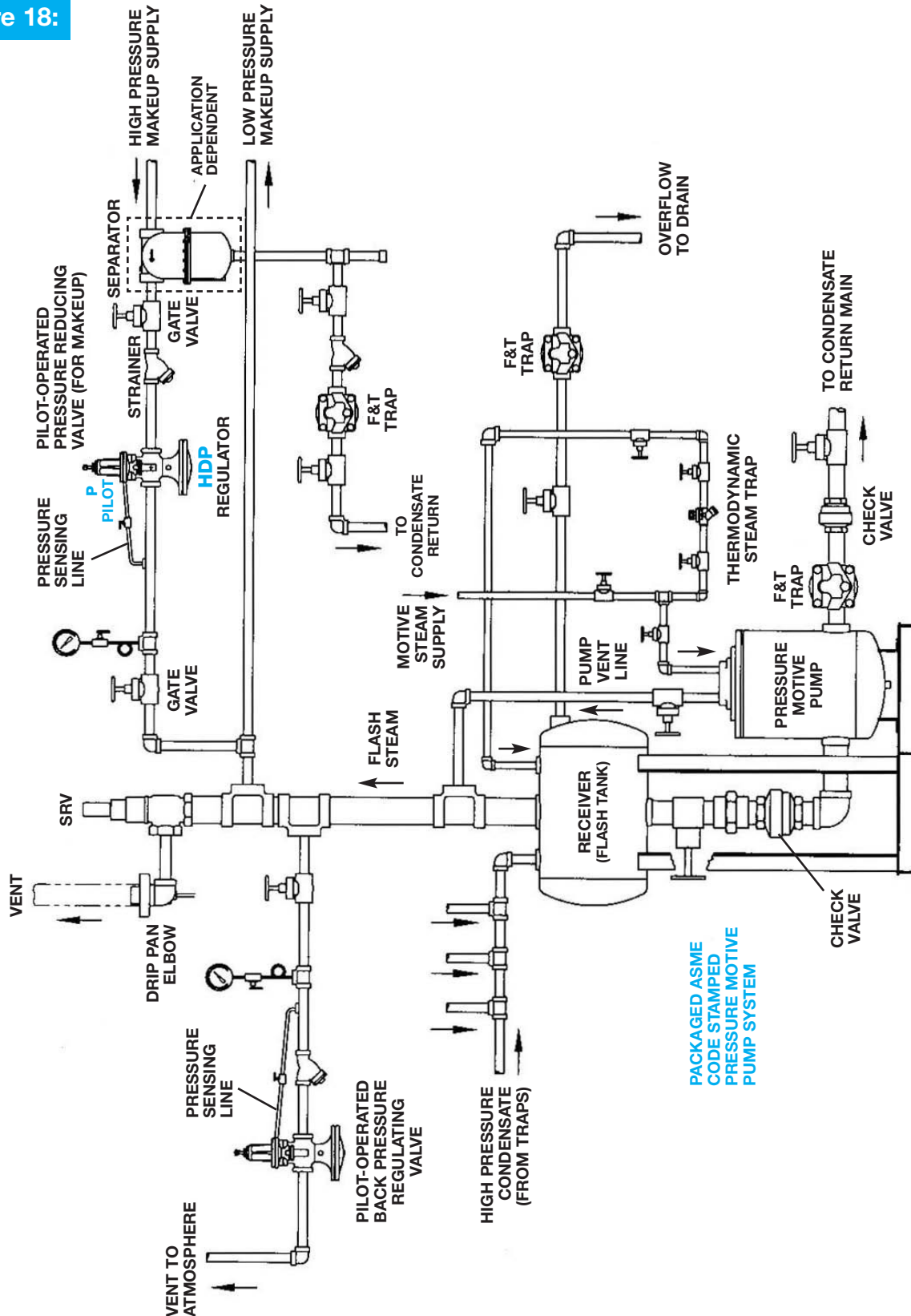

FLASH STEAM RECOVERY
(PMP APPLICATIONS)

PRESSURE MOTIVE PUMP (PMP) APPLICATIONS

REMOVAL OF WATER OR CONDENSATE FROM A PIT

PURPOSE: For drainage of water and condensate from collection pits – especially with minimal horizontal space.

OPERATION: Water enters the inlet check valve through a screened area at the bottom of the PMPSP Sump Drainer. After the pump fills, the internal mechanism is actuated and the water is discharged from the pump by motive steam or compressed air or other gas.

INSTALLATION GUIDELINES: (see Figure 19)

- Make certain vent line is unobstructed and allowed to discharge directly to atmosphere.
- Other compressed gases, such as nitrogen, may be used as a motive source.
- Pit diameter should be at least 18" to ensure proper installation and operation.
- Proper installation and piping of the pump vent line is critical to ensure the system operates correctly. Follow guidelines or consult factory for additional information.

Figure 19: "The Pit Boss"

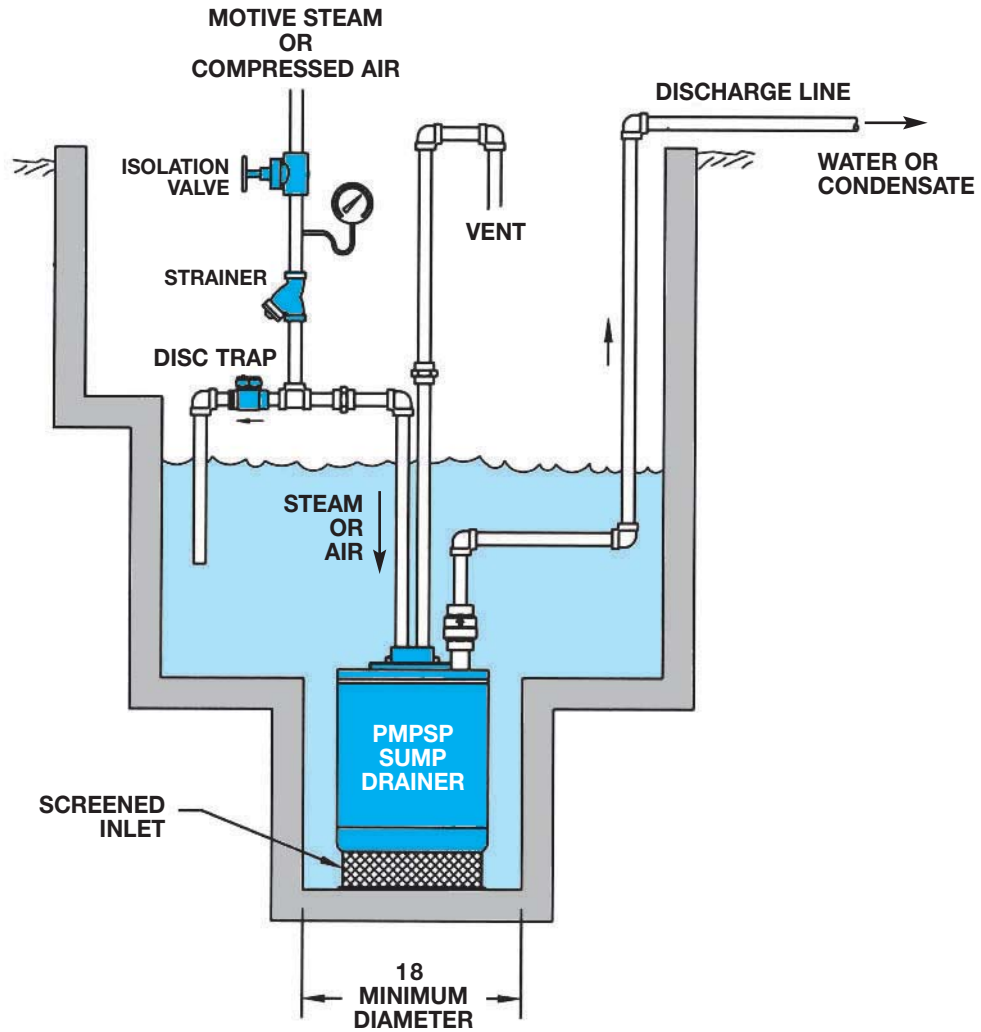

PMPSP Sump Drainer ("The Pit Boss")

Product Cross Reference

Steam Traps

THERMODYNAMIC TRAPS

Manufacturer		Watson McDaniel		Armstrong		Spence Nicholson		Hoffman		Spirax Sarco		Yarway		TLV	
Desc.	Size	Product	F/F Dim	Product	F/F Dim	Product	F/F Dim	Product	F/F Dim	Product	F/F Dim	Product	F/F Dim	Product	F/F Dim
Standard 600 PSI															
Disc Trap	3/8"	WD600	2"	CD-33	3.31"	NTD600	2"	TD6523	2"	TD-52	2"	29	2"		
	1/2"		2.7"				2.68"	TD6524	2.75"		2.7"		2.25"		
	3/4"		2.8"				2.81"	TD6526	2.75"		2.8"		2.87"		
	1"		3.3"				3.31"	TD6528	3.25"		3.3"		3.37"		
Low Capacity Disc Trap	1/2"	WD600L	2.7"	CD-33L	3.31"	S610L	3.25"			TD-52L	2.7"				
	3/4"		2.8"				3.25"	2.8"							
Low Capacity Disc Trap w/ Strainer	1/2"	WD600LS	3.1"	CD-33SL	3.31"					TD-42L	3.1"				
	3/4"		3.5"			3.31"		3.5"							
	1"		3.7"			3.31"		3.7"							
Disc Trap with Strainer	1/2"	WD600S	3.1"	CD-33S	3.5"	NTD600S	2"	TD6424	3.06"	TD-42H	3.1"	129Y	2.76"	A3N	3.87"
	3/4"		3.5"				2.68"	TD6426	3.06"		3.5"		2.95"	P46SS	2.75"
Disc Trap with Strainer & Blowdown	1/2"	WD600SB	3.5"	CD-33SB	3.5"	NTD600SB	2"			TD-42HB	3.5"	129YB	2.76"	A3N	3.87"
	3/4"		3.7"				2.68"		3.7"		2.95"		P46SS	2.75"	
Low Cap. Disc Trap w/ Strainer & Blowdown	3/4"	WD600LSB	3.5"	CD-33SBL	3.5"					TD-42LB	3.5"				
	1"		3.72"					3.7"							
Repairable In-line															
Disc Trap with Strainer	1/2"	WD700S	3.16"			S610	3.25"					721	3.15"	A46S	3.12"
	3/4"		3.55"								3.54"		A50S		
	1"		6.31"								3.93"		P46SRN		
Disc Trap with Strainer & Blowdown	1/2"	WD700SB	3.16"									721	3.15"	A46S	3.12"
	3/4"		3.55"								3.54"		A50S		
	1"		6.31"								3.93"		P46SRN		
High-Pressure Repairable In-line															
Disc Trap with Strainer	1/2"	WD700HS	3.15"									721HP	3.15"		
	3/4"		3.54"								3.54"				
	1"		6.31"								3.93"				
Disc Trap w/ Strainer & Blowdown	1/2"	WD700HSB	3.15"									721HP	3.15"		
	3/4"		3.54"								3.54"				
	1"		6.31"								3.93"				
High-Pressure Repairable In-line – 900 PSI															
Disc Trap with Strainer	1/2"	WD900S	3.6"							TD62	3.6"	460D3	4.81"	A65SS	3.12"
	3/4"		3.6"						3.6"		4.81"		3.12"		
	1"		6.5"						3.9"		4.81"		3.43"		
Ultra High-Pressure Repairable In-line – 3600 PSI															
Disc Trap	1/2"	WD3600	6.2"							TD120	6.2"			HR150A	5.88"
	3/4"		6.2"						6.2"						
	1"		6.2"						6.2"						

Steam Traps (continued)

THERMOSTATIC TRAPS													
Manufacturer		Watson McDaniel		Armstrong		Spence Nicholson		Spirax Sarco		Hoffman		TLV	
Desc.	Size	Product	F/F Dim	Product	F/F Dim	Product	F/F Dim	Product	F/F Dim	Product	F/F Dim	Product	F/F Dim
Non-Repairable													
Thermostatic 300 PSI	1/2"	WT1000	2.5"					TSS300	2.5"			LV21	2.18"
	3/4"		2.5"				2.5"		2.18"				
Thermostatic 650 PSI	1/2"	WT2000C	3.75"	WT-1	4.5"	TA	3.75"	DTS300	2.5"				
	3/4"		3.75"	TTF-1	4.69"		3.93"		2.5"				
Repairable													
Thermostatic 250 PSI	1/2"	WT2500	3"			N450	3"						
	3/4"		3"				3"						
Thermostatic 650 PSI	1/2"	WT3000	4.5"			N650	5"						
	3/4"		4.5"				5"						
Thermostatic 650 PSI with Strainer	1/2"	WT3000S	4.5"			N650Y	5"	TM600N	5.25"			L21S	3.12"
	3/4"		4.5"				5"		5.25"	L32S			
Thermostatic 650 PSI with Strainer & Blowdown	1/2"	WT3000SB	4.5"			N650Y	5"					L21S	3.12"
	3/4"		4.5"				5"		L32S				
Thermostatic 300 PSI	3/4"	WT4000	4.5"			N450	3"						
	1"		4.5"				3"						
Thermostatic 300 PSI with Strainer	3/4"	WT4000S	4.5"			N450Y	3"						
	1"		4.5"				3"						
Thermostatic 300 PSI w/ Strainer & Blowdown	3/4"	WT4000SB	4.5"			N450Y	3"						
	1"		4.5"				3"						
Thermostatic 125 PSI, Angle*	1/2"	TT125	2.81"	TS-3	3.12"	N125	2.75"	RTA-125	2.8"	17C	3.24"	RT3A	3.12"
	3/4"		3.06"		3.5"		3.18"		3"		8C		3.12"
Adjustable Bi-Metallic													
1/2"	WT5000	3.12"	2.75"									LEX3N-TZ	2.75"
												LEXW3N-TZ	
												LEXF3N-TZ	
3/4"	WT5000	3.12"										LEX3N-TZ	3.12"
												LEXW3N-TZ	
												LEXF3N-TZ	
1"	WT5000	3.12"										LEX3N-TZ	3.12"
												LEXW3N-TZ	
												LEXF3N-TZ	

* Right Angle (90°) Ports

Steam Traps (continued)

FLOAT & THERMOSTATIC TRAPS															
Manufacturer		Watson McDaniel			Armstrong			Hoffman		Spence Nicholson		Spirax Sarco		TLV	
Desc.	Size	Product	F/F Dim	Product	F/F Dim	Product	F/F Dim	Product	F/F Dim	Product	F/F Dim	Product	F/F Dim	Product	F/F Dim
Ductile Iron – Repairable In-Line															
In-Line	1/2"	FTT	4.8"	B12	2.75"	FTI	5.5"	FTE10	5.06"	FT14	4.8"	J3X	4.75"		
	3/4"		4.8"	B13	2.75"		5.5"		5.06"		4.8"		4.75"		
	1"		4.8"	B14	3"		5.5"		5.06"		4.7"		4.75"		
	1.5"		10.6"	B16	4.18"				11.12"		10.6"		11"		
	2"		11.9"	B18	6"				12.12"		11.9"		J87	21.31"	
High Capacity	1.5"	FTE	3"					3"		3"					
	2"		4.5"	J&L	6.62"	FT-X-8	6.3"	HC	6.62"	FTB	4.5"				
	2.5"		7.25"	K&M	11.31"	FT-C-10	9.5"		9.5"		7.25"				
Cast Iron – Repairable In-Line															
15 PSI	3/4"	WFT-015	3.3"	15-B3	2.75"	FT015H-3	3.93"	FTN	3.31"	FT-15	3.3"	SJ3-1	3.31"		
	1"		3.3"	15-B4	3"	FT015H-4	3.93"		3.31"		3.3"	SJ3-1	5.12"		
	1.25"		3"	15-B5	3"	FT015H-5	3"		3"		3"	SJ5-1	3"		
	1.5"		3"	15-B6	4.18"	FT015H-6	3"		3"		4.25"	SJ6-1	4.93"		
	2"		4.9"	15-B8	6"	FT015H-8	4.94"		4.94"		4.9"	SJ6-1	4.93"		
30 PSI	3/4"	WFT-030	3.3"	30-B3	2.75"	FT030H-3	3.31"	FTN	3.31"	FT-30	3.3"	SJ3-2	5.12"		
	1"		3.3"	30-B4	3"	FT030H-4	3.31"		3.31"		3.3"	SJ3-2	5.12"		
	1.25"		3"	30-B5	3"	FT030H-5	3"		3"		3"	SJ5-2	3"		
	1.5"		3"	30-B6	4.18"	FT030C-6	3"		3"		4.25"	SJ6-2	4.06"		
	2"		4.9"	30-B8	6"	FT030C-8	4.94"		4.94"		4.9"	SJ6-2	4.93"		
75 PSI	3/4"	WFT-075	3.3"	75-A3	2.75"	FT075H-3	3.31"	FTN	3.31"	FT-75	3.3"	SJ3-5	5.12"		
	1"		3.3"	75-A4	3"	FT075H-4	3.31"		3.31"		3.3"	SJ3-5	5.12"		
	1.25"		3"	75-A5	3"	FT075C-5	3"		3"		4.25"	SJ5-5	3"		
	1.5"		3"	75-A6	4.18"	FT075C-6	3"		3"		4.25"	SJ6-10	4.93"		
	2"		4.9"	75-A8	6"	FT075C-8	4.94"		4.94"		4.9"	SJ7-10	4.93"		
125 PSI	3/4"	WFT-125	3.3"	125-A3	2.75"	FT125H-3	3.31"	FTN	3.31"	FT-125	3.3"	SJ3-10	5.12"		
	1"		3.3"	125-A4	3"	FT125H-4	3.31"		3.31"		3.3"	SJ3-10	5.12"		
	1.25"		3"	125-A5	3"	FT125C-5	3"		3"		4.25"	SJ5-10	3"		
	1.5"		3"	125-A6	4.18"	FT125C-6	3"		3"		4.25"	SJ6-10	4.93"		
	2"		4.9"	125-A8	6"	FT125C-8	4.94"		4.94"		4.9"	SJ7-10	4.93"		
175 PSI	3/4"	WFT-175	3"	175-A3	2.75"	FT175H-3	3.31"			FT-200	3.3"	SJ3-14	5.12"		
	1"		3"	175-A4	3"	FT175H-4	3.31"				3.3"	SJ3-14	5.12"		
	1.25"		3"	175-A5	3"	FT175C-5	3"				4.25"	SJ5-14	3"		
	1.5"		3"	175-A6	4.18"	FT175C-6	3"				4.25"	SJ6-14	4.93"		
	2"		4.5"	175-A8	6"	FT175C-8	4.94"				4.9"	SJ7-14	4.93"		
250 PSI	3/4"	WFT-250	3"							FT-200	3.3"	SJ3-14	5.12"		
	1"		3"						3.3"		SJ3-14	5.12"			
	1.25"		3"								4.25"	SJ5-14	3"		
	1.5"		3"								4.25"	SJ6-14	4.93"		
	2"		4.5"								4.9"	SJ7-14	4.93"		
H Pattern 15 PSI	3/4"	FT3	4.12"			FT015H-3	3.31"								
	1"	FT4	4.12"			FT015H-4	3.31"								
	1.25"	FT6	5"			FT015H-5	3"								
	1.5"	FT7	6.37"			FT015H-6	5.25"								
	2"	FT8	6.5"			FT015H-8	7.46"								
H Pattern 30 PSI	3/4"	FT33	4.12"			FT030H-3	3.31"								
	1"	FT34	4.12"			FT030H-4	3.31"								
	1"	FT35	5"												
	1.25"	FT36	5"			FT030H-5	3"								
	1.5"	FT37L	6.37"			FT030H-6	5.25"								
2"	FT38	6.5"													
H Pattern 75 PSI	3/4"	FT73	4.12"			FT075H-3	3.31"								
	1"	FT74	4.12"			FT075H-4	3.31"								
	1"	FT75	5"												
	1.25"	FT76	5"												
	1.5"	FT77L	6.37"												
2"	FT78	6.5"													

Steam Traps (continued)

FLOAT & THERMOSTATIC TRAPS (continued)														
Manufacturer		Watson McDaniel		Armstrong		Hoffman		Spence Nicholson		Spirax Sarco		TLV		
Desc.	Size	Product	F/F Dim	Product	F/F Dim	Product	F/F Dim	Product	F/F Dim	Product	F/F Dim	Product	F/F Dim	
Carbon Steel														
In-Line	3/4"	FT600	6.1"	CS	6.75"			FTE44 NFT650	5.12" 5.5"	FT450	6.1"	JH3X	5.12"	
	1"		6.5"	CS	8.37"			FTE44 NFT650	5.12" 11"	FT450	6.5"	JH3X	5.25"	
	1.5"		9.8"	CS	11"			FTE44 NFT650	11.12" 13.75"	FT450	9.8"	JH7.2X	16"	
	2"		11.8"	CS	11"			FTE44 NFT650	12.12" 13.75"	FT450	11.8"	JH8RX	23.25"	
	3"		27.55"								FT450	27.55"	JL10	10.32"
			39"									39"	JL16	
	4"		39"								FT450	39"	J10	23.43" 24.06"
Offset	2.5"	FTES	8.4"	LS	11.31"					FTB	9.25"			
Stainless Steel														
In-Line	3/4"	FT601	6.1"							FT46	5.8"			
	1"		6.5"						6.2"					
	1.5"		9.8"						9"					
	2"		11.8"						9"					
	3"		27.55"											
			39"											
	4"		39"											

INVERTED BUCKET (IB) TRAPS													
Manufacturer		Watson McDaniel		Armstrong		Hoffman		Spence Nicholson		Spirax Sarco			
Desc.	Size	Product	F/F Dim	Product	F/F Dim	Product	F/F Dim	Product	F/F Dim	Product	F/F Dim		
Cast Iron													
IB Trap	1/2"	1031	5"	800	5"					B1H	5"		
	3/4"		5"		5"				5"				
	1/2"	1032	5"	811	5"	B1-2	6.93"			B2	6.6"		
	3/4"		5"		5"	B1-3	6.93"						
	1"		5"		5"								
	1/2"	1033	6.5"	812	6.5"	B2-2	6.93"			B2	6.6"		
	3/4"		6.5"		6.5"	B2-3	6.93"						
	3/4"	1034	7.75"	813	7.75"					B2	6.6"		
1"	7.75"		7.75"						B3			7.9"	
IB Trap with Strainer	1/2"	1041	5"	880	5"			80S	5.06"		5"		
	3/4"		5"		5"				5.06"	5"			
	1/2"	1042	5"	881	5"	B1S-2	6.93"	81S	5.06"				
	3/4"		5"		5"	B1S-3	6.93"		5.06"	B2S	6.6"		
	3/4"		7.12"		7.87"				82S	7"	B2S	6.6"	
	1"	1044	7.12"	883	7.87"			83S	8.12"	B3S	7.9"		
	1.25"		7.12"		7.87"				B4S	9.3"			
	1.5"		7.12"										

STAINLESS STEEL INVERTED BUCKET (SS IB) TRAPS									
Manufacturer		Watson McDaniel		Armstrong		Spence Nicholson		Spirax Sarco	
Desc.	Size	Product	F/F Dim	Product	F/F Dim	Product	F/F Dim	Product	F/F Dim
SS IB Trap	1/2"	WSIB	4.55"	1810	4.31"	TSBT-LS/MS	4.31"	SIB30	4.3"
	3/4"		4.55"		4.31"		4.3"		
SS IB Trap Hi Cap.	1/2"	WSIBH	4.55"	1811	4.31"		4.31"	SIB30H	4.3"
	3/4"		4.55"		4.31"		4.3"		

Steam Traps (continued)

UNIVERSAL CONNECTORS											
Manufacturer		Watson McDaniel		Armstrong		Spence Nicholson		Spirax Sarco		TLV	
Desc.	Size	Product	F/F Dim	Product	F/F Dim	Product	F/F Dim	Product	F/F Dim	Product	F/F Dim
Universal Connector	1/2"	WU450	2.92"	IS-2	3.5"	UMTC	3.5"	UPC	2.4"		
	3/4"		2.92"		3.5"		3.5"		2.9"		
	1"		5.66"		3.5"		3.5"		3.6"		
Universal Connector w/ Str	1/2"	WU450S	3.31"			UMTCY	3.5"			FS	3.12"
	3/4"		3.31"				3.5"				3.12"
	1"		6.06"				3.5"				3.75"
Universal Connector w/ Str/BD	1/2"	WU450SB	3.31"							FS	3.12"
	3/4"		3.31"						3.12"		
	1"		6.06"						3.75"		
Universal Connector w/ Str	1/2"	WU450S-LR WU450S-RL	3.31"	IS-2	3.5"			USC	3.2"		
	3/4"		3.31"		3.5"				3.5"		
	1"		3.62"		3.5"				3.9"		
Universal Connector w/ Str/BD	1/2"	WU450SB-LR WU450SB-RL	3.31"					USCB	3.2"		
	3/4"		3.31"						3.5"		
	1"		3.62"						3.9"		

Str = Strainer; BD = Blowdown Valve

UNIVERSAL STEAM TRAP MODULES					
Description	Watson McDaniel	Armstrong	Spence Nicholson	Spirax Sarco	TLV
Standard Thermodynamic	WD450		UMT-TD10		
Standard Thermodynamic LC	WD450L		UMT-TD10L		
SM Thermodynamic	WD450SM	CD-3300		UTD52H	FP32
SM Thermodynamic LC	WD450LSM			UTD52L	
SM Thermodynamic LC/HP	WD600LSM-HP			UTD52L-HP	
Thermostatic	WT450	WT-2000	UMT450T	UBP32	FL21
		TT-2000			FL32
Float & Thermostatic	WFT450	FT-4000		UFT14	FS3 FS5
Inverted Bucket	WSIB450	2010	USBT	UIB30	
Inverted Bucket HP	WSIB450H	2011	USBT	UIB30H	
Bi-Metallic	WB450	AB-2000		USM21	FX-1

SM = Side Mount; LC = Low Capacity; HP = High Pressure

SANITARY / CLEAN STEAM TRAPS					
Description	Watson McDaniel	Armstrong	Spence Nicholson	Spirax Sarco	TLV
Thermostatic Repairable, Angle*	FDA400		CDH		
Thermostatic Repairable	FDA500		CDS	BT6	SS5P
Thermostatic	FDA600		DS100	BTM7	
Thermodynamic	FDA800		NTD230L	BTD52L	P10

* Right Angle (90°) Ports

Pressure Motive Pumps

PRESSURE MOTIVE PUMPS						
Description	Watson McDaniel	Armstrong	Spence Nicholson	Spirax Sarco	Hoffman	TLV
Cast Iron Mini	PMPM	PT104		PPEC		GP10L
Upright Ductile Iron	PMPC	PT3500	P3	PPC	PCC	GP10
				PTC		GP14
Upright Carbon Steel	PMPF	PT400	P3 Classic Vertical	PPF	PCS	GP10F
				PTF		GP14F
Low Profile Carbon Steel	PMPLS	PT200	P3 Little Boy	PPEC		GP10L
Hi-Cap 4"x4" Carbon Steel	PMPBP	PT516	Big Boy	PTF4		
PUMP-TRAP COMBINATION						
1"x1" PMPM & FTE-200	WPT1	Double Duty 4		APT-10		GT10L-1
1 1/4"x1 1/4" PMPM & FTE-200	WPT2					
1 1/2"x1 1/2" PMPLS & FTE-200	WPT3	Double Duty 6		APT-14		GT10L-1-1/2
2"x2" PMPC & FTE-200	WPT4			APT-14HC		
3"x2" PMPC & FTE-200	WPT5					
1", 1 1/2" PMP w/ Internal Trap	PMPT	Double Duty 4		APT-14		GL10L-1

SKID MOUNTED PUMP SYSTEMS			
Watson McDaniel	Armstrong	Spirax Sarco Pivitol	Spence Nicholson Condensate Commander
PMPM Simplex, 6" x 36" Receiver	SPT-104LBRP-6 (4 Gallon)	PPEC Simplex	
PMPM Simplex, 8" x 36" Receiver	SPT-104LBRP-8 (7 Gallon)		
PMPM Simplex, 10" x 36" Receiver	SPT-104LBRP-10 (10 Gallon)	PPEC Simplex, 12 Gallon	
PMPM Duplex, 21-Gallon Receiver	DPT-104LBRP-12 (22 Gallon)	PPEC Duplex	
PMPC Simplex, 6" x 36" Receiver	SPT-200LBRP-6		
PMPC Simplex, 8" x 36" Receiver	SPT-200LBRP-8	PTC Simplex	
PMPC Simplex, 10" x 36" Receiver	SPT-200LBRP-10		
PMPC Simplex, 21-Gallon Receiver	SPT-200LBRP-16 (30 Gallon)	PTC Simplex, 31 Gallon	
PMPC Duplex, 21-Gallon Receiver	DPT-200LBRP-12	PTC Duplex, 31 Gallon	
PMPC Duplex, 75-Gallon Receiver	DPT-200LBRP-24 (85 Gallon)	PTC Duplex, 65 Gallon	
PMPF Simplex, 10" x 36" Receiver	SPT-400LBRP-10	PTF Simplex, 12 Gallon	
PMPF Simplex, 21-Gallon Receiver	SPT-400LBRP-16	PTF Simplex, 31 Gallon	Classic Vertical Simplex, 25 Gallon
PMPF Duplex, 21-Gallon Receiver	DPT-400LBRP-12	PTF Duplex, 31 Gallon	Classic Vertical Duplex, 25 Gallon
PMPF Duplex, 75-Gallon Receiver	DPT-400LBRP-24	PTF Duplex, 65 Gallon	Classic Vertical Duplex, 65 Gallon
PMPF Triplex, 116-Gallon Receiver	TPT-400LBRP (24" x 72")	PTF Triplex, 135 Gallon	Classic Vertical Triplex, 115 Gallon
PMPF Quadraplex, 116-Gallon Receiver	QPT-400LBRP (24" x 72")	PTF Quadraplex, 185 Gallon	Classic Vertical Quadraplex, 250 Gallon
PMPC Simplex, 10" x 36" Receiver	SPT-3500LBRP-10	PTC Simplex	
PMPC Simplex, 21-Gallon Receiver	SPT-3500LBRP-16	PTC Simplex, 31 Gallon	
PMPC Duplex, 21-Gallon Receiver	DPT-3500LBRP-12	PTC Duplex, 31 Gallon	
PMPC Duplex, 75-Gallon Receiver	DPT-3500LBRP-24	PTC Duplex, 65 Gallon	
PMPC Triplex	TPT-3500LBRP	PTC Triplex	
PMPC Quadraplex	QPT-3500LBRP	PTC Quadraplex	
PMPF Simplex, 10" x 36" Receiver	SPT-300LBRP-10	PTF Simplex	
PMPF Simplex, 21-Gallon Receiver	SPT-300LBRP-16	PTF Simplex, 31 Gallon	Classic Vertical Simplex, 25 Gallon
PMPF Duplex, 21-Gallon Receiver	DPT-300LBRP-12	PTF Duplex, 31 Gallon	Classic Vertical Duplex, 25 Gallon
PMPF Duplex, 75-Gallon Receiver	DPT-300LBRP-24	PTF Duplex, 65 Gallon	Classic Vertical Duplex, 65 Gallon
PMPF Triplex	TPT-300LBRP	PTF Triplex	Classic Vertical Triplex
PMPF Quadraplex	QPT-300LBRP	PTF Quadraplex	Classic Vertical Quadraplex
PMPBP Simplex, 116-Gallon Receiver	SPT-516RP (24" x 72")	PTF4 Simplex	Big Boy Simplex
PMPBP Duplex, 280-Gallon Receiver	DPT-516RP (30" x 84")	PTF4 Duplex	Big Boy Duplex

Pressure & Temperature Regulators

PILOT-OPERATED REGULATING VALVES						
Description	Watson McDaniel	Armstrong	Spence Nicholson	Spirax Sarco	Hoffman	Fisher Controls
External Pilot-Operated Main Valve, Ductile Iron	HD	GP	E	25	2100	92
Pressure Pilot	P	GP-2000	D	P	SPS	92B
Temperature Pilot	T/TU	OB-2000	T124 T14	T	STPA	
Temperature Pilot w/ Dial	TRP		T14			
Air Pilot	A	GP-2000K	A	A	AP	
Back Pressure Pilot	BP	GP-2000R	Q	BP		
Solenoid Pilot	S	GP-2000	M	E		
Pneumatic Temperature Controller	PTL/PTR	OBK-2000	T61/62/63/64			
Differential Pressure Pilot	DP		Type N			

SELF-CONTAINED PRESSURE REDUCING VALVES							
Description	Watson McDaniel	Armstrong	Spence Nicholson	Spirax Sarco	Hoffman	Watts	TLV
Cast Iron, Steam, Water & Air Service	O-Series	GD30 GD6(N)	D-50	BRV	754	152	
Ductile Iron, Piston Actuated High-Capacity Steam & Air Service	402/403	GP-1000 GP-18/28 GP-1					COSR ACOSR
Bronze & Cast Iron Water, Air & Oil Service	B-Series	GD-200	D-34		740	223	

TEMPERATURE REGULATING VALVES					
Description	Watson McDaniel	Trerice	Powers	Spence Nicholson	Hoffman
Direct Acting, Heating w/ Dial	175 *	91000	11	2000	1140
	175T **	91400			
Reverse Acting, Cooling w/ Dial	153 *	91000	11	2000	1140R
	153T **	91400			
Heating or Cooling, w/o Dial	W91	91000	11	2000	1140
					1140R
Heating or Cooling, w/ Dial	W94	91400	11	2000	1140
					1140R

* Watson McDaniel Models 175 & 153 were upgraded to Model W91.

** Watson McDaniel Models 175T & 153T were upgraded to Model W94.

BACK PRESSURE / RELIEF VALVES		
Description	Watson McDaniel	Fisher Controls
Bronze & Cast Iron Water, Air & Oil Service	3040	98H
Bronze Water Service	R-Series & 10691	

Liquid Drainers

LIQUID DRAINERS					
Description	Size	Watson McDaniel	Armstrong	Spirax Sarco	Hoffman
High Capacity Float Type					
Ductile Iron	1.5"	WLDE		FAB	
	2"		JD & L		
	2.5"		KD & L		
Float Type					
Ductile Iron	1/2" - 2"	WLD1400		CA14	
				FAI	
				CA10S	
Cast Iron	3/4" - 2"	WLD1900	21	FA	793
Carbon Steel	2.5"	WLDES-300	LS	FAB	
	3/4" - 4"	WLD600	LS	FA450	
			MS		
Stainless Steel	3/4" - 4"	WLD601		CA46S	
	1/2", 3/4"	WLD1800	11-LD	CAS14	
		WLD1800R	32-LD		
Thermodynamic Type					
Stainless Steel	1/2"	WLD1703S		TDA52	656A
Inverted Bucket Type					
Cast Iron	3/4", 1"	WLD1500	1-LD		

Air Eliminators, Air Vents & Vacuum Breakers

AIR ELIMINATORS & AIR VENTS					
Description	Watson McDaniel	Armstrong	Spirax Sarco	Hoffman	Spence Nicholson
Float-Type Air Eliminators					
Cast Iron	AV813W	21AR	13WS	792	
Stainless Steel	AE1800	11AV			
		22AV			
	AE1800R	32AV			
Thermostatic Air Vents					
Stainless Steel	AV2000C	TTF-1	VS204		TAV
			VS206 (Cast Iron)		
Brass	AVT125	TS-2	T202	17C	
		SV-12A		8C	

VACUUM BREAKERS			
Description	Watson McDaniel	Spirax Sarco	Hoffman
Stainless Steel	WVBSS	VB21	62
Brass		VB14	

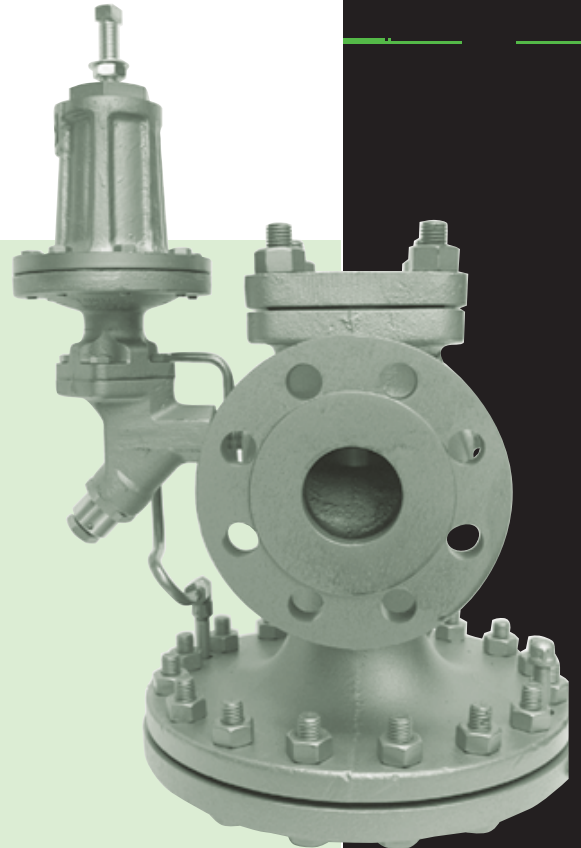
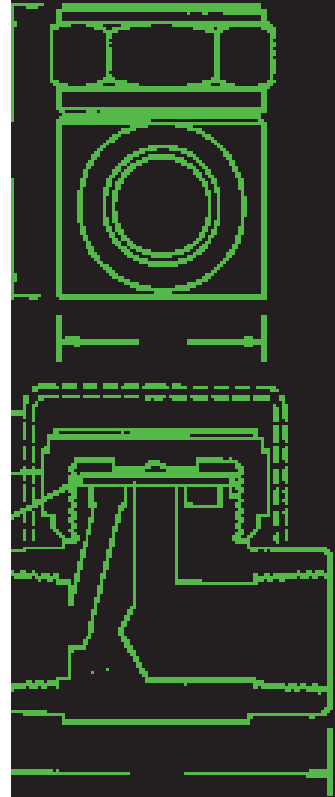

Watson McDaniel reserves the right to change the designs and/or materials of its products without notice. The contents of this publication are the property of Watson McDaniel and cannot be reproduced by any other party without written permission. All rights reserved. Copyright © 2010 Watson McDaniel Incorporated.

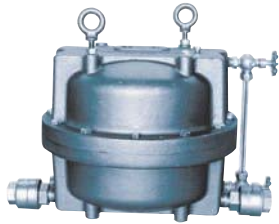

428 Jones Boulevard
Limerick Airport Business Center
Pottstown PA • 19464
Tel. 610.495.5131
Fax. 610.495.5134

www.watsonmcdaniel.com

